

32bit	TX09 Series Under Development TMPA912CMXBG	361pin
-------	--	--------

**High-performance 32-bit RISC microcontrollers
with a USB device controller capable of operating at up to 200 MHz**

Features

● **ARM926EJ-S™ CPU Core**

- Operating voltage:
Internal:1.4 to 1.6 V I/O:1.7 to 1.9 V, 3.0 to 3.6 V
- Minimum instruction execution time:
5 ns (200 MHz internal, 0 to 70°C)
6.67 ns (150 MHz internal, -20 to 85°C)
- Data cache: 16 Kbytes
- Instruction cache: 16 Kbytes
- Internal ROM: 16 Kbytes (Boot)
- Internal RAM: 32 Kbytes
- External data bus width: Up to 16 bits

● **On-chip Functions**

- Color LCD controller (24-bit TFT/STN) : 1 channel
- LCD data process accelerator
- Memory controller
 - Static memory
 - SDR SDRAM
 - LVC MOS DDR SDRAM
- NAND Flash controller : 2 channels
- CMOS image sensor interface : 1 channel
- USB (High-speed) device controller : 1 channel
- DMA controller : 8 channels
- SSP (SPI/MicroWire mode) : 2 channels
- RTC : 1 channel

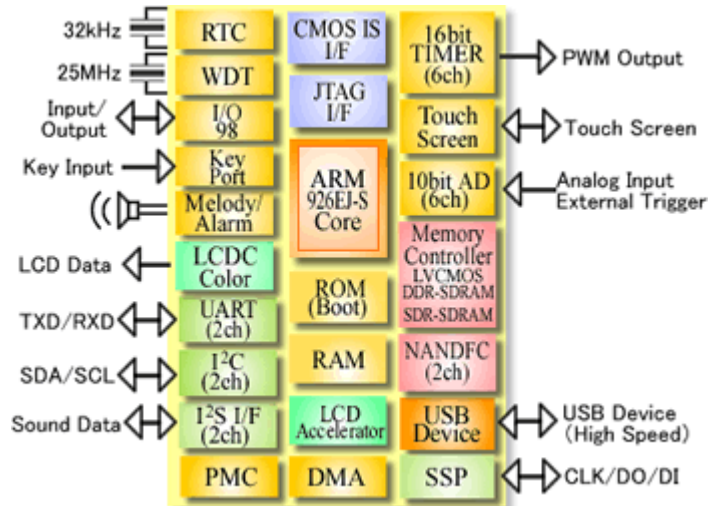

- UART : 2 channels
- I²C : 2 channels
- I²S interface : 2 channels
- 10-bit AD converter : 6 channels
- 16-bit timer : 6 channels
- Touch-screen interface : 1 channel
- JTAG interface
- Power management circuit (PMC)

Package Information

● **Pin Assignments**

A1	A2	A3	A4	A5	A6	A7	A8	A9	A10	A11	A12	A13	A14	A15	A16	A17	A18	A19
B1	B2	B3	B4	B5	B6	B7	B8	B9	B10	B11	B12	B13	B14	B15	B16	B17	B18	B19
C1	C2	C3	C4	C5	C6	C7	C8	C9	C10	C11	C12	C13	C14	C15	C16	C17	C18	C19
D1	D2	D3	D4	D5	D6	D7	D8	D9	D10	D11	D12	D13	D14	D15	D16	D17	D18	D19
E1	E2	E3	E4	E5	E6	E7	E8	E9	E10	E11	E12	E13	E14	E15	E16	E17	E18	E19
F1	F2	F3	F4	F5	F6	F7	F8	F9	F10	F11	F12	F13	F14	F15	F16	F17	F18	F19
G1	G2	G3	G4	G5	G6	G7	G8	G9	G10	G11	G12	G13	G14	G15	G16	G17	G18	G19
H1	H2	H3	H4	H5	H6	H7	H8	H9	H10	H11	H12	H13	H14	H15	H16	H17	H18	H19
J1	J2	J3	J4	J5	J6	J7	J8	J9	J10	J11	J12	J13	J14	J15	J16	J17	J18	J19
K1	K2	K3	K4	K5	K6	K7	K8	K9	K10	K11	K12	K13	K14	K15	K16	K17	K18	K19
L1	L2	L3	L4	L5	L6	L7	L8	L9	L10	L11	L12	L13	L14	L15	L16	L17	L18	L19
M1	M2	M3	M4	M5	M6	M7	M8	M9	M10	M11	M12	M13	M14	M15	M16	M17	M18	M19
N1	N2	N3	N4	N5	N6	N7	N8	N9	N10	N11	N12	N13	N14	N15	N16	N17	N18	N19
P1	P2	P3	P4	P5	P6	P7	P8	P9	P10	P11	P12	P13	P14	P15	P16	P17	P18	P19
R1	R2	R3	R4	R5	R6	R7	R8	R9	R10	R11	R12	R13	R14	R15	R16	R17	R18	R19
T1	T2	T3	T4	T5	T6	T7	T8	T9	T10	T11	T12	T13	T14	T15	T16	T17	T18	T19
U1	U2	U3	U4	U5	U6	U7	U8	U9	U10	U11	U12	U13	U14	U15	U16	U17	U18	U19
V1	V2	V3	V4	V5	V6	V7	V8	V9	V10	V11	V12	V13	V14	V15	V16	V17	V18	V19
W1	W2	W3	W4	W5	W6	W7	W8	W9	W10	W11	W12	W13	W14	W15	W16	W17	W18	W19

·Package name:
FBGA361-P-1616-0.80AZ

Top View

● Pin Numbers and Names (1/3)

Ball No.	Pin name	Ball No.	Pin name	Ball No.	Pin name
C3	SP0/TCK	L6	PC5/MLDALMn/INT8	T6	SW2/NDALE
D4	SP1/TMS	K2	DVCC3I04	N8	SW1/NDWEn
K8	DVSSCOM1	L5	PC6/I2C0CL	U6	SV3/NDD3
D3	SP2/TDI	L1	PC2/PWE	W3	DVCC3I09
B1	DVCC3I01	L4	PT5/U1RXD	N9	SV6/NDD6
E5	SP5/TDO	K3	DVSSCOM7	R7	SV2/NDD2
E4	SP4/RTCK	N7	PT4/U1TXD	N10	SW0/NDREn
F5	SP3/TRSTn	M1	PC7/I2C0DAINT9	R8	PP2/INT2
G6	DVCC3CMS1	T1	SM4/RESETh	V4	DVCC1A3
G5	PF6/I2C1CL	P7	TEST05	T7	SV5/NDD5
F4	PF7/I2C1DAINTC	L2	DVCC3I05	V5	SV1/NDD1
H7	PF1/CMSHSY	N6	TEST04	P9	PP1/INT1
J7	PE7/CMSD7	L3	TEST03	L9	DVSSCOM11
E3	PF2/CMSHBK	M2	TEST02	P10	SV4/NDD4
D2	PF3/CMSVSY	M8	DVSSCOM8	U7	SV0/NDD0
K8	DVSSCOM2	P1	TEST07	R9	PP0/INT0
F3	PF0/CMSPK	M4	TEST15	W4	DVCC3I010
L7	PE8/CMSD6	M3	TEST06	M10	DVSSCOM12
C2	PE3/CMSD3	M5	TEST01	V6	SN2/SELJTAG
G4	PE4/CMSD4	N2	DVCC3I06	T8	SM6/AM0
E2	PE5/CMSD5	N5	TEST00	U8	SM7/AM1
K6	DVCC3CMS2	R2	DVCC1A2	W5	DVCC3I011
C1	PE0/CMSD0	P6	TEST16	R10	SN0/SELMBMC
H5	PE1/CMSD1	R1	TEST14	T10	SN1/SELVCCM
G3	PE2/CMSD2	R6	TEST12	W6	DVCC1C
J8	DVSSCOM3	P2	TEST11	W7	SM0/X1
D1	PT2/SP0D0	P4	DVSSCOM9	V7	DVSS1C
H4	PT0/SP0FSS	N3	TEST10	W8	SM1/X2
E1	DVCC3I02	N1	TEST17	V8	DVCC1C
H6	PN1/U0RXD/SIROIN	N4	TEST13	U9	PT7/X1USB
F2	PN0/U0TXD/SIROOUT	P3	DVCC3I07	T9	DVCC1A4
J5	PT3/SP0DI	T2	VREFH	K9	DVSSCOM13
F1	DVCC1A1	U2	VREFL	V9	AVDD3C
J8	DVSSCOM4	U1	AVSS3AD	W9	SR4/VSENSE
H3	PT1/SP0CLK	V1	AVCC3AD	V10	SR3/REXT
K5	PT6/U1CTSn	P5	PD5/AN5MY	W10	AVSS3C
G2	PN4/U0DSRn/INTD	R3	PD4/AN4MK	U10	AVDD3T1
M6	PN7/U0RTSn/INTG	R5	PD3/AN3	V11	AVSS3T3
G1	DVCC3I03	R4	PD2/AN2	U11	AVSS3T2
J4	PN3/U0DDCn	T5	PD1/AN1	W11	SR1/DM
H2	PN5/U0RIn/MNTE	T3	PD0/AN0	W12	SR0/DP
K4	PN2/U0CTSn	U3	PD6/PX/INTA(TSI)	V12	AVSS3T1
H1	PN6/U0DTRn/INTF	T4	PD7/PY/INTB	U12	AVSS3T1
L8	DVSSCOM5	V2	DVCC3I08	W13	AVSS3T0
J1	SM2/XT1	V3	SW6/NDRB	V13	AVDD3T0
K1	SM3/XT2	U4	SW4/NDCEBn	J10	DVSSCOM14
M9	DVSSCOM6	W2	SW5/NDCE1n	V14	DVCC1A6
J3	PC4/FSOUT/PWM2OUT	U5	SW3/NDCLE	T11	PM0/I2S1WS
M7	DVCC1B1	L9	DVSSCOM10	V15	PM2/I2S1DAT0
J2	PC3/MLDALM/PWM0OUT	P8	SV7/NDD7	R11	PL2/I2S0DAT1/SP1D0

● Pin Numbers and Names (2/3)

Ball No.	Pin name	Ball No.	Pin name	Ball No.	Pin name
W14	PL4/I2SSCLK	M14	TEST33	E19	DVCC1A9
T12	DVCC3I2S1	R18	SB1/D9	H14	TEST36
U13	PL1/I2SDCLK/SP1CLK	M15	TEST32	F18	SE4/A4
P11	PM3/I2S1MCLK	T19	DVCCM6	G15	SG4/A20
W16	PM1/I2S1CLK	M16	SB7/D15	J11	DVSSCOM26
N11	PL3/I2SDMCLK/SP1DI	P18	SB4/D12	G16	SG2/A18
L10	DVSSCOM15	L11	DVSSCOM21	G17	SF4/A12
R12	PL0/I2SDWS/SP1FSS	L12	PP3/INT3	F15	SG5/A21
U14	DVCC3I2S2	M17	PP4/INT4	D19	DVCCM9
T13	PR0/RESETOUTn	L13	PP5/INT5	F16	SG3/A19
W15	PR1/SMCW/Pn/FCOUT	R19	PP6/INT6	E18	SE5/A6
W17	DVCC1A6	L14	PP7/INT7	F17	SF5/A13
U15	DVCCM1	N18	PA0/K10	G14	DVSSCOM27
R13	TEST23	P19	DVCC3I012	E15	SG6/A22
V16	SA0/D0	N19	PA1/K11	D18	SE6/A6
P12	TEST26	L15	PA2/K12	C19	SE7/A7
M11	DVSSCOM16	L17	PA3/K13	E16	DVCCM10
P13	TEST25	L16	PA4/K14	C18	SF1/A9
W18	SL6/DMCCLKIN	M18	PA6/K15	E17	SF6/A14
P14	TEST24	L11	DVSSCOM22	D17	SF7/A15
U15	DVCCM2	M19	PA6/K16	H13	DVSSCOM28
T14	TEST21	K16	PA7/K17	B19	SF0/A8
V17	SA1/D1	L19	DVCC1A6	C17	SG0/A16
V18	SA2/D2	K15	PB0/K00	D16	DVSSCOM29
M11	DVSSCOM17	L18	PB1/K01	B18	TEST43
R14	TEST22	K13	PB2/K02	A18	TEST42
R15	TEST20	K17	SM5/TEST0n	D15	DVCCM11
U16	SA3/D3	K19	DVCC3I013	C16	SL2/DMCAP
T15	DVCCM3	K18	PB3/K03	E14	SG7/A23
T16	SA6/D5	K14	PB4/K04	D14	DVSSCOM30
U17	SL4/DMCDDQS0	J19	PB5/K05	C15	SJ4/DMCBA0
V19	SL5/DMCDDQS1	K11	DVSSCOM23	C14	SJ5/DMCBA1
N13	DVSSCOM18	J18	PB6/K06	F14	DVSSCOM31
T17	SA6/D6	J15	PB7/K07	F13	SH1/A25
R17	SB0/D8	H19	PC0/K08	E13	DVCC1A10
R16	SA7/D7	J16	PC1/K09	B17	SK0/DMCSDQM0/DMCDDM0
P15	DVCCM4	K11	DVSSCOM24	B16	DVCCM12
N14	TEST30	J14	DVCC1B2	G13	SH0/A24
U18	SA4/D4	J17	SF2/A10	A17	DVSSCOM32
P16	SB2/D10	J13	TEST37	D13	TEST47
M12	DVSSCOM19	H18	SE2/A2	C13	SJ2/DMCRA5n
N15	TEST27	K12	DVCCM7	B13	DVSSCOM33
P17	SB3/D11	G19	SE0/A0	D12	SK5/SMCBE1n
U19	DVCC1A7	H16	SG1/A17	H12	PR2/INTH
N12	TEST31	G18	SE3/A3	B15	DVCCM13
T18	DVCCM5	J12	DVSSCOM25	F12	SH2/SMCBE0n
M13	TEST34	H17	SF3/A11	C12	TEST46
N17	SB6/D14	H15	TEST35	E12	SK4/SMCWEn
N16	SB5/D13	F19	SE1/A1	A14	DVSSCOM34
K10	DVSSCOM20	K12	DVCCM8	A16	SL0/DMCCLKP

● Pin Numbers and Names (3/3)

Ball No.	Pin name	Ball No.	Pin name
A15	SL1/DMCCLKn	A4	DVCC3LCD4
A14	DVSSCOM35	J6	PJ2/LD10
B14	SK1/DMCSDQM1/DMCDDM1	B3	PJ1/LD9
D11	SJ7/SMCAVOn	E7	SU2/LCLE
F10	DVCCM14	C8	DVSSCOM43
G12	SJ1/DMCWEh	G8	PJ5/LD13
A13	SL3/SMCCLK	A3	PJ4/LD12
F11	DVCC1A1	D6	PJ3/LD11
B11	DVSSCOM36	A2	DVCC3LCD5
E11	SJ0/SMCOEh	C4	SU1/LCLAC
B12	SJ3/DMCCASn	E6	PJ7/LD15
A12	DVSSCOM37	D5	PJ6/LD14
B10	SH5/SMCCS2n	H9	DVSSCOM44
E10	SH6/SMCCS3n	C5	SU3/LCLFP
A12	DVSSCOM38	F7	SU4/LCLLP
D10	SH3/SMCCS0n	F6	PK7/LD23
A11	SJ6/DMCKE	B2	DVCC1A14
F10	DVCCM15		
C10	SH4/SMCCS1n		
C11	SH7/DMCCSn		
A10	DVSSCOM39		
G11	SL7/SMCWAJTh		
A9	DVCC1A12		
G10	PK1/LD17		
B9	PK0/LD16		
D9	DVCC3LCD1		
C9	ST2/LD2		
E9	ST1/LD1		
A8	ST0/LD0		
H11	DVSSCOM40		
B8	PK4/LD20		
F9	PK3/LD19		
A7	PK2/LD18		
D8	DVCC3LCD2		
B7	ST5/LD5		
G9	ST4/LD4		
C8	ST3/LD3		
H10	DVSSCOM41		
A6	SU0/LCLCP		
E8	PK6/LD22		
B6	PK5/LD21		
D7	DVCC3LCD3		
C7	PJ0/LD8		
H8	ST7/LD7		
B5	ST6/LD6		
J9	DVSSCOM42		
A6	DVCC1A13		
F8	SU7/LPRG2		
B4	SU6/LPRG1		
K7	SU5/LPRG0		

- » ARM is a registered trademark and ARM926EJ-STM is a trademark of ARM Limited in the EU and other countries.
- » For further information about Toshiba microcomputers, please visit <http://www.semicon.toshiba.co.jp/eng/product/micro/index.html>
- » Contact the Toshiba sales representative for information about RoHS compliance before you purchase any components.

- Toshiba Corporation, and its subsidiaries and affiliates (collectively "TOSHIBA"), reserve the right to make changes to the information in this document, and related hardware, software and systems (collectively "Product") without notice.
 - This document and any information herein may not be reproduced without prior written permission from TOSHIBA. Even with TOSHIBA's written permission, reproduction is permissible only if reproduction is without alteration/omission.
 - Though TOSHIBA works continually to improve Product's quality and reliability, Product can malfunction or fail. Customers are responsible for complying with safety standards and for providing adequate designs and safeguards for their hardware, software and systems which minimize risk and avoid situations in which a malfunction or failure of Product could cause loss of human life, bodily injury or damage to property, including data loss or corruption. Before creating and producing designs and using, customers must also refer to and comply with (a) the latest versions of all relevant TOSHIBA information, including without limitation, this document, the specifications, the data sheets and application notes for Product and the precautions and conditions set forth in the "TOSHIBA Semiconductor Reliability Handbook" and (b) the instructions for the application that Product will be used with or for. Customers are solely responsible for all aspects of their own product design or applications, including but not limited to (i) determining the appropriateness of the use of this Product in such design or applications; (b) evaluating and determining the applicability of any information contained in this document, or in charts, diagrams, programs, algorithms, sample application circuits, or any other referenced documents; and (c) validating all operating parameters for such designs and applications. TOSHIBA ASSUMES NO LIABILITY FOR CUSTOMERS' PRODUCT DESIGN OR APPLICATIONS.
 - Product is intended for use in general electronics applications (e.g., computers, personal equipment, office equipment, measuring equipment, industrial robots and home electronics appliances) or for specific applications as expressly stated in this document. Product is neither intended nor warranted for use in equipment or systems that require extraordinarily high levels of quality and/or reliability and/or a malfunction or failure of which may cause loss of human life, bodily injury, serious property damage or serious public impact ("Unintended Use"). Unintended Use includes, without limitation, equipment used in nuclear facilities, equipment used in the aerospace industry, medical equipment, equipment used for automobiles, trains, ships and other transportation, traffic signaling equipment, equipment used to control combustions or explosions, safety devices, elevators and escalators, devices related to electric power, and equipment used in finance-related fields. Do not use Product for Unintended Use unless specifically permitted in this document.
 - Do not disassemble, analyze, reverse-engineer, alter, modify, translate or copy Product, whether in whole or in part.
 - Product shall not be used for or incorporated into any products or systems whose manufacture, use, or sale is prohibited under any applicable laws or regulations.
 - The information contained herein is presented only as guidance for Product use. No responsibility is assumed by TOSHIBA for any infringement of patents or any other intellectual property rights of third parties that may result from the use of Product. No license to any intellectual property right is granted by this document, whether express or implied, by isotrop or otherwise.
 - ABSENT A WRITTEN SIGNED AGREEMENT, EXCEPT AS PROVIDED IN THE RELEVANT TERMS AND CONDITIONS OF SALE FOR PRODUCT, AND TO THE MAXIMUM EXTENT ALLOWABLE BY LAW, TOSHIBA (1) ASSUMES NO LIABILITY WHATSOEVER, INCLUDING WITHOUT LIMITATION, INDIRECT, CONSEQUENTIAL, SPECIAL, OR INCIDENTAL DAMAGES OR LOSS, INCLUDING WITHOUT LIMITATION, LOSS OF PROFITS, LOSS OF OPPORTUNITIES, BUSINESS INTERRUPTION AND LOSS OF DATA, AND (2) DISCLAIMS ANY AND ALL EXPRESS OR IMPLIED WARRANTIES AND CONDITIONS RELATED TO SALE, USE OF PRODUCT, OR INFORMATION, INCLUDING WARRANTIES OR CONDITIONS OF MERCHANTABILITY, FITNESS FOR A PARTICULAR PURPOSE, ACCURACY OF INFORMATION, OR NONDERIVEMENT.**
 - Do not use or otherwise make available Product or related software or technology for any military purposes, including without limitation, for the design, development, use, stockpiling or manufacturing of nuclear, chemical, or biological weapons or missile technology products (mass destruction weapons). Product and related software and technology may be controlled under the Japanese Foreign Exchange and Foreign Trade Law and the U.S. Export Administration Regulations. Export and re-export of Product or related software or technology are strictly prohibited except in compliance with all applicable export laws and regulations.
 - Product may include products subject to foreign exchange and foreign trade control laws.
 - Please contact your TOSHIBA sales representative for details as to environmental matters such as the RoHS compatibility of Product. Please use Product in compliance with all applicable laws and regulations that regulate the inclusion or use of controlled substances, including without limitation, the EU RoHS Directive. TOSHIBA assumes no liability for damages or losses occurring as a result of noncompliance with applicable laws and regulations.
- In addition to the above, the following are applicable only to development tools.
- Though TOSHIBA works continually to improve Product's quality and reliability, Product can malfunction or fail. Use the Product in a way which minimizes risk and avoid situations in which a malfunction or failure of Product could cause loss of human life, bodily injury or damage to property, including data loss or corruption. For using the Product, customers must also refer to and comply with the latest versions of all relevant TOSHIBA information, including without limitation, this document, the instruction manual, the specifications, the data sheets for Product.
 - Product is provided solely for the purpose of performing the functional evaluation of a semiconductor product. Please do not use Product for any other purpose, including without limitation, evaluation in high or low temperature or humidity, and verification of reliability.
 - Do not incorporate Product into your products or system. Products are for your own use and not for sale, lease or other transfer.

TOSHIBA
TOSHIBA CORPORATION
Semiconductor Company
<http://www.semicon.toshiba.co.jp/eng>

Mouser Electronics

Authorized Distributor

Click to View Pricing, Inventory, Delivery & Lifecycle Information:

[Toshiba:](#)

[TMPA912CMXBG](#)

Компания «Life Electronics» занимается поставками электронных компонентов импортного и отечественного производства от производителей и со складов крупных дистрибьюторов Европы, Америки и Азии.

С конца 2013 года компания активно расширяет линейку поставок компонентов по направлению коаксиальный кабель, кварцевые генераторы и конденсаторы (керамические, пленочные, электролитические), за счёт заключения дистрибьюторских договоров

Мы предлагаем:

- Конкуренспособные цены и скидки постоянным клиентам.
- Специальные условия для постоянных клиентов.
- Подбор аналогов.
- Поставку компонентов в любых объемах, удовлетворяющих вашим потребностям.
- Приемлемые сроки поставки, возможна ускоренная поставка.
- Доставку товара в любую точку России и стран СНГ.
- Комплексную поставку.
- Работу по проектам и поставку образцов.
- Формирование склада под заказчика.
- Сертификаты соответствия на поставляемую продукцию (по желанию клиента).
- Тестирование поставляемой продукции.
- Поставку компонентов, требующих военную и космическую приемку.
- Входной контроль качества.
- Наличие сертификата ISO.

В составе нашей компании организован Конструкторский отдел, призванный помогать разработчикам, и инженерам.

Конструкторский отдел помогает осуществить:

- Регистрацию проекта у производителя компонентов.
- Техническую поддержку проекта.
- Защиту от снятия компонента с производства.
- Оценку стоимости проекта по компонентам.
- Изготовление тестовой платы монтаж и пусконаладочные работы.



Тел: +7 (812) 336 43 04 (многоканальный)
Email: org@lifeelectronics.ru