



# **CrossLink LIF-MD6000 Master Link Board**

## **Evaluation Board User Guide**

EB105 Version 1.0

May 2016

## Contents

Acronyms in This Document .....	3
1. Introduction .....	4
2. Headers and Test Connections .....	6
3. Programming Circuit .....	7
3.1. Bridging Circuit .....	7
3.2. I <sup>2</sup> C Expander .....	8
4. Power Supply .....	9
5. Status Indicators .....	11
References .....	12
Technical Support Assistance .....	12
Appendix A. LIF-MD6000-ML-EVN-BRD Schematics .....	13
Appendix B. LIF-MD6000-ML-EVN-BRD Bill of Materials .....	21
Appendix C. SMA-IOL-EVN-BRD Schematics .....	27
Appendix D. SMA-IOL-EVN-BRD Bill of Materials .....	28
Appendix E. B-IOL-EVN-BRD Schematics .....	29
Appendix F. B-IOL-EVN-BRD Bill of Materials .....	30
Revision History .....	31

## Figures

Figure 1.1. Top View of Master Link Board and its Key Components .....	4
Figure 1.2. Bottom View of Master Link Board .....	5
Figure 3.1. Programming Block .....	7
Figure 3.2. Bridging Block .....	8
Figure 3.3. I <sup>2</sup> C Expander Block .....	8
Figure 4.1. Power Supply Block .....	9

## Tables

Table 2.1. Headers and Test Connectors .....	6
Table 4.1. Power LEDs .....	9
Table 4.2. Device Power Rail Summary and Test Points .....	10
Table 5.1. Status LED I/O Map .....	11

## Acronyms in This Document

A list of acronyms used in this document.

Acronym	Definition
CMOS	Complementary Metal-Oxide Semiconductor
CSI-2	Camera Serial Interface
DSI	Display Serial Interface
FTDI	Future Technology Devices International
I <sup>2</sup> C	Inter-Integrated Circuit
LVDS	Low-Voltage Differential Signaling
SPI	Serial Peripheral Interface

# 1. Introduction

This document describes the Lattice Semiconductor CrossLink™ LIF-MD6000 Master Link board that supports a variety of demos, encompassing different signaling logic standards bridging with MIPI® CSI-2/DSI interface. The board’s key component is the CrossLink Family device that features built in MIPI D-PHY hard blocks to support different bridging solutions.

For the latest information about this board, including optional Tx/Rx Link boards, demo files, further documentation and more, see the Lattice website at: [www.latticesemi.com/masterlink](http://www.latticesemi.com/masterlink)

For details about the CrossLink device refer to DS1055, [CrossLink Family Data Sheet](#).

The content of this user guide includes descriptions of on-board jumper settings, programming circuit, a complete set of schematics, and bill of materials for LIF-MD6000 Master Link board.

Refer to Appendix A, B, C, D, E, F for the schematics and BOM of the CrossLink LIF-MD6000 Master Link board and the schematics and BOMs of the Breakout IOlink and SMA IOlink boards that are included in the demo kit.

Circuits on the development kit board:

- Programming Circuit
  - Mini USB Type-B connector to FTDI
  - FTDI to CrossLink using SPI
  - FTDI to XO3LF device using JTAG
- CrossLink
  - MIPI CSI-2/DSI hard block
  - Bridging of multiple signaling standards
  - SPI flash configuration
  - General Purpose Input/Output
  - LED display
- LCMXO3LF-1300E
  - I<sup>2</sup>C muxing

Figure 1.1 shows the top view of the LIF-MD6000 Master Link board and its key components. Figure 1.2 on the next page shows the bottom view of the board.

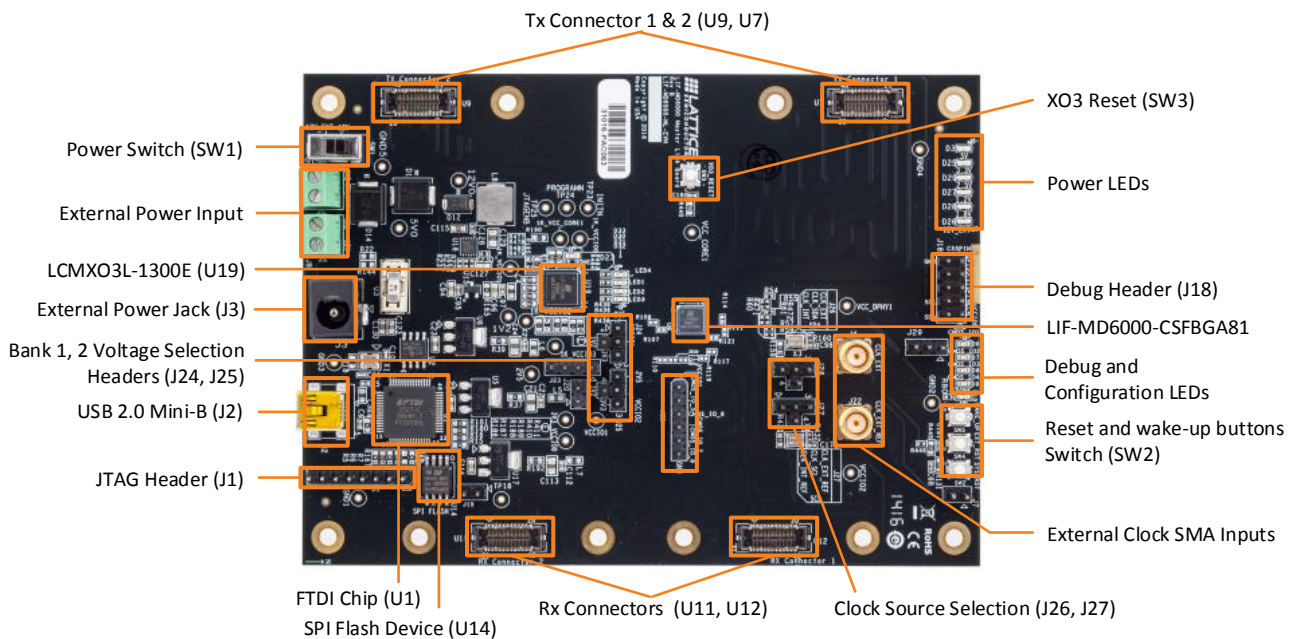

**Figure 1.1. Top View of Master Link Board and its Key Components**

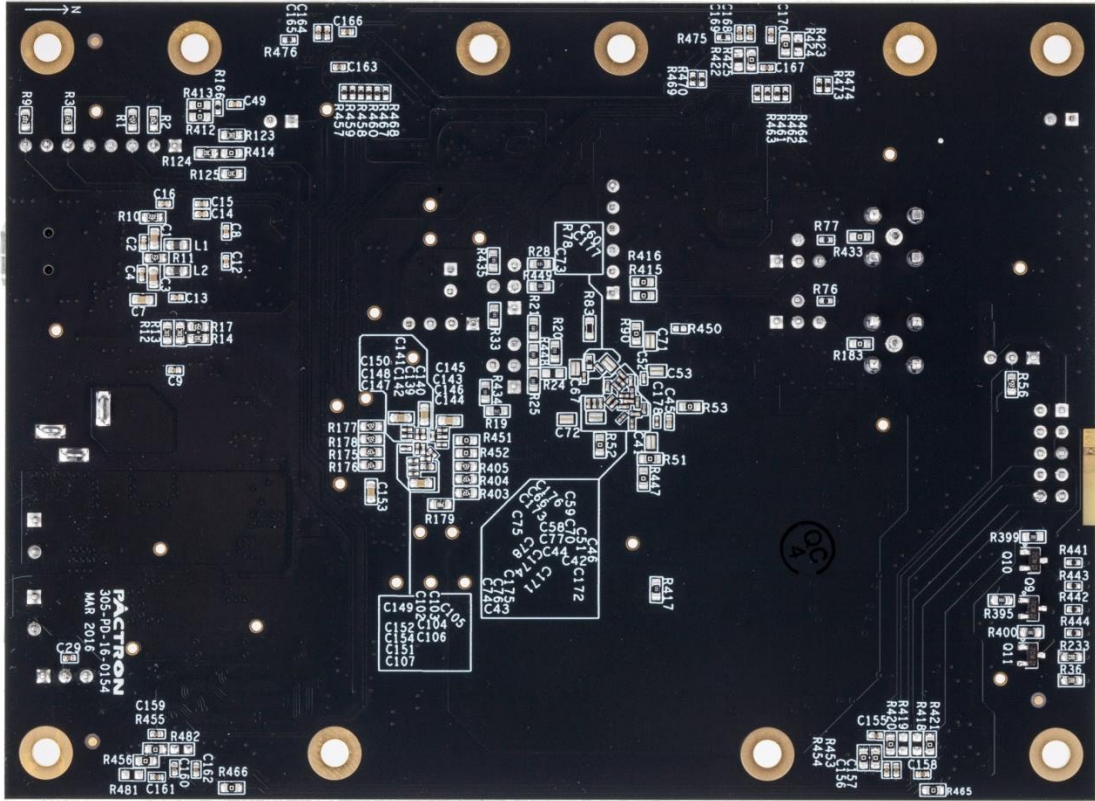

Figure 1.2. Bottom View of Master Link Board

## 2. Headers and Test Connections

Figure 1.1 shows the top view of the Master Link board. The headers and test connections on the board provide access to LIF-MD6000 Master Link demo board circuits. Table 2.1 lists the headers and test connectors.

**Table 2.1. Headers and Test Connectors**

Part	Description	Setting
J1	External JTAG interface - For LCMX03 only	—
J8	External 12 V terminal block	Open
J9	External 5 V terminal block	Open
SW1	External adaptor power ON/OFF	—
J22	External reference clock input for MIPI D-PHY reference clock	—
J21	External or internal reference clock selection	1–2 (External), 2–3 (Internal)
J5	Debug I/O	—
J20	LIF-MD6000 chip select	OPEN-OFF, SHORT-ON
J19	SPI Flash chip select	OPEN-OFF, SHORT-ON
J4	External clock input for MIPI D-PHY reference clock	—
J6	External or internal clock selection	1–2 (External), 2–3 (Internal)
J18	External SP/I <sup>2</sup> C access	—
SW2	Configuration reset for LIF-MD6000	—
J29	Reset signal voltage selector	1-2 (VCCIO2), 2-3 (VCCIO0)
J28	Reveal analyzer signal connector	—
J26	Internal/External clock and I2C SDA Mux	1-2 (CLK_INT), 2-3 (CLK_EXT), 2-4 (SDA)
J27	Internal/External reference clock and I2C SCL Mux	1-2 (CLK_INT_REF), 2-3 (CLK_EXT_REF), 2-4 (SCL)
J24	VCCIO1 Bank voltage selector	1-2 (2.5 V), 2-3 (3.3 V), 2-4 (1.2 V)
J25	VCCIO1 Bank voltage selector	1-2 (2.5 V), 2-3 (3.3 V), 2-4 (1.2 V)
J3	External power jack	—
U7, U9	Tx Connectors for external interface	—
U11, U12	Rx Connectors for external interface	—
SW4	External reset for LIF-MD6000 device	—
SW3	External reset for LCMX03L device	—
SW5	PMU WAKEUP Switch	—
J23	Debug Header for LCMX03L device	—

### 3. Programming Circuit

The Mini-B USB connector is used for programming the board by using Lattice Diamond® programmer software. Figure 3.1 shows the programming block of LIF-MD6000 Master Link board.

The Mini-B USB connector interfaces to the FTDI FT2232H IC. The FTDI IC works with Diamond programmer software to provide interfaces for:

- JTAG – to program MachXO2-1300E
- SPI – to program both CrossLink, and SPI Flash Memory

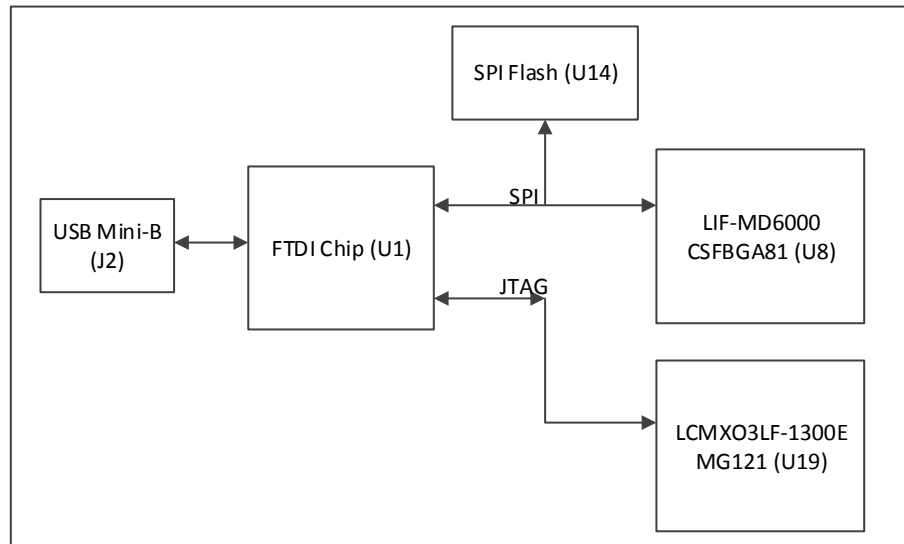

Figure 3.1. Programming Block

#### 3.1. Bridging Circuit

Figure 3.2 shows the block diagram of bridging of different standard interfaces. The CrossLink device is used as a bridging device that supports a variety of I/O standards. This demo board supports development of the following interface bridges:

- 1:1 MIPI DSI Display Interface Bridge
- 1:2 MIPI DSI Display Interface Bridge
- 2:1 MIPI CSI-2 Image Sensor Aggregator Bridge
- CMOS to MIPI CSI-2 Image Sensor Interface Bridge
- MIPI CSI-2 to CMOS Image Sensor Interface Bridge
- MIPI DSI to CMOS Display Interface Bridge
- OpenLDI LVDS to MIPI DSI Display Interface Bridge
- CMOS to MIPI DSI Display Interface Bridge

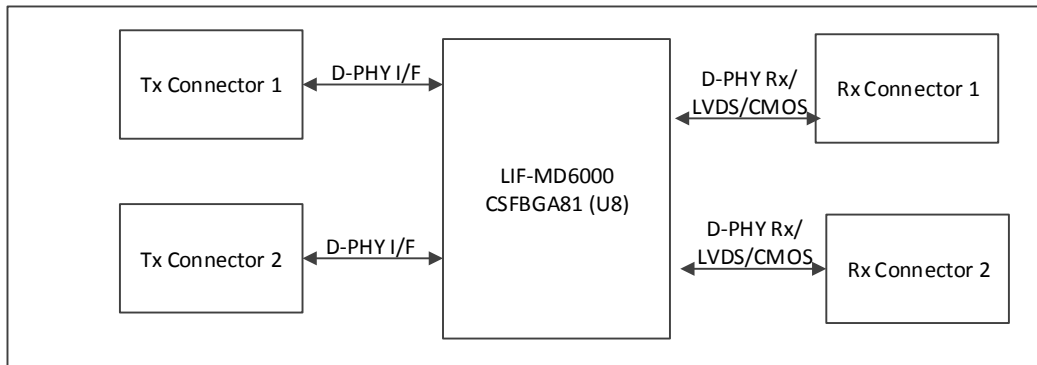

Figure 3.2. Bridging Block

### 3.2. I<sup>2</sup>C Expander

Figure 3.3 shows the block diagram of the I<sup>2</sup>C expander. The LCMXO3LF-1200E device is used as an I<sup>2</sup>C expander and it supports a single master and multiple slave devices connected to the board. The master I<sup>2</sup>C interface is connected to the Tx header and the slave device I<sup>2</sup>C interface is connected to the Rx connectors supporting any slave device access from the master based on the slave address.

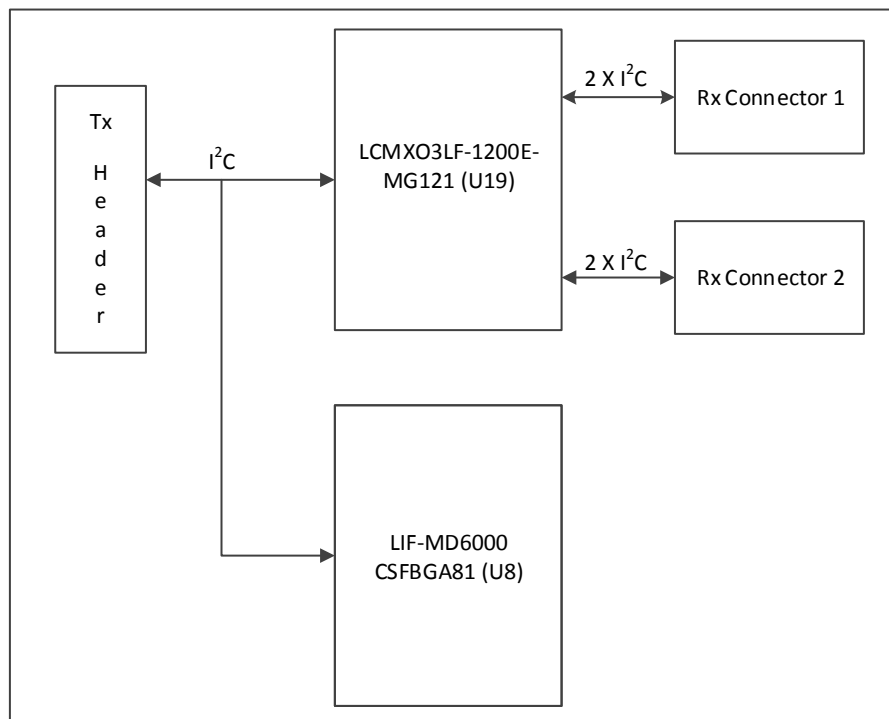

Figure 3.3. I<sup>2</sup>C Expander Block



## 4. Power Supply

The power supply to the development kit is provided by the Mini-B USB connector or from an external adaptor.

Figure 4.1 shows the power supply block of the CrossLink LIF-MD6000 Master Link board. The Mini-B USB connector is used only for programming and the onboard power regulator for the successful programming. The external adaptor provides 12 V power source through voltage regulators on the board to CrossLink and LCMXO3LF-1300E, as well as to the external boards connected to Tx and Rx Headers. Each I/O and core voltage rail on the board is accessible by a test point on the board. The current flowing to each rail can be measured using a 1  $\Omega$  resistor placed in the path of each voltage rail.

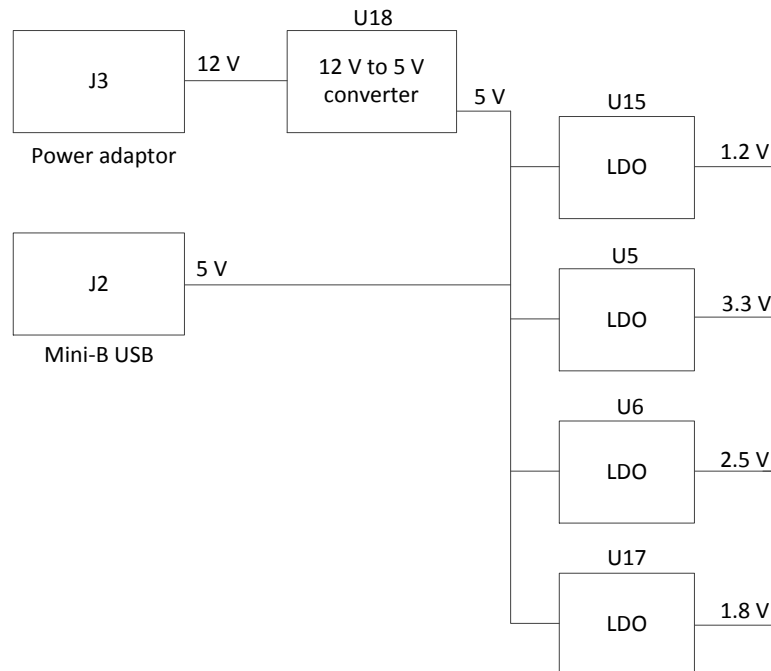

**Figure 4.1. Power Supply Block**

Table 4.1 lists the device power rails. There are five voltage regulators on the board used to supply the 5 V, 3.3 V, 2.5V, 1.8 V, and 1.2 V rails. The input to these regulators is either from the Mini-B USB connector or the external 12 V adaptor that is connected to the board. Switch SW2 is used to connect or disconnect the external adaptor power to the board.

**Table 4.1. Power LEDs**

Voltage Rail	LEDs	Colour
12	D26	Green
5	D3	Green
3.3	D25	Green
2.5	D29	Green
1.8	D28	Green
1.2	D27	Green

Table 4.2 on the next page lists the board voltage rails, including the rail source voltage, test point number, and current sense resistor number.

**Table 4.2. Device Power Rail Summary and Test Points**

Voltage Rail	Source Rail	Current Sense Resistor	Test Points
12 V	12_Ext	—	12V
5 V	12 V	—	5V
+3.3 V	5 V	—	3V3
+2.5 V	5 V	—	2V5
+1.8 V	5 V	—	1V8
+1.2 V	5 V	—	1V2
VCCCORE	+1.2 V	R19	VCC_CORE
VCCIO0	+3.3 V	R20	VCCIO0
VCCIO1	+3.3 V	R21	VCCIO1
VCCIO2	+3.3 V	R28	VCCIO2
VCC_DPHY	+1.2 V	R417	VCC_DPHY
1K_VCC_CORE	1.2 V	R190	1K_VCC_CORE
1K_VCCIO0	+3.3 V	R410	1K_VCCIO0
1K_VCCIO1	+3.3 V	R184	1K_VCCIO1
1K_VCCIO2	+3.3 V	R186	1K_VCCIO2
1K_VCCIO3	+3.3 V	R188	1K_VCCIO3

## 5. Status Indicators

The LED status indicators on the board show power, configuration, and application status. [Table 5.1](#) lists the status LED I/O map.

**Table 5.1. Status LED I/O Map**

Device	LED	Net Name	Colour
CrossLink	D6	CMOS_IO_1	Blue
CrossLink	D7	CMOS_IO_2	Blue
CrossLink	D8	CMOS_IO_3	Blue
CrossLink	D9	CMOS_IO_4	Blue
CrossLink	D10	CDONE	Green
LCMX03LF-1300E	D23	DONE	Red

## References

For more information, refer to:

DS1055, [CrossLink Family Data Sheet](#)

## Technical Support Assistance

Submit a technical support case through [www.latticesemi.com/techsupport](http://www.latticesemi.com/techsupport).

## Appendix A. LIF-MD6000-ML-EVN-BRD Schematics

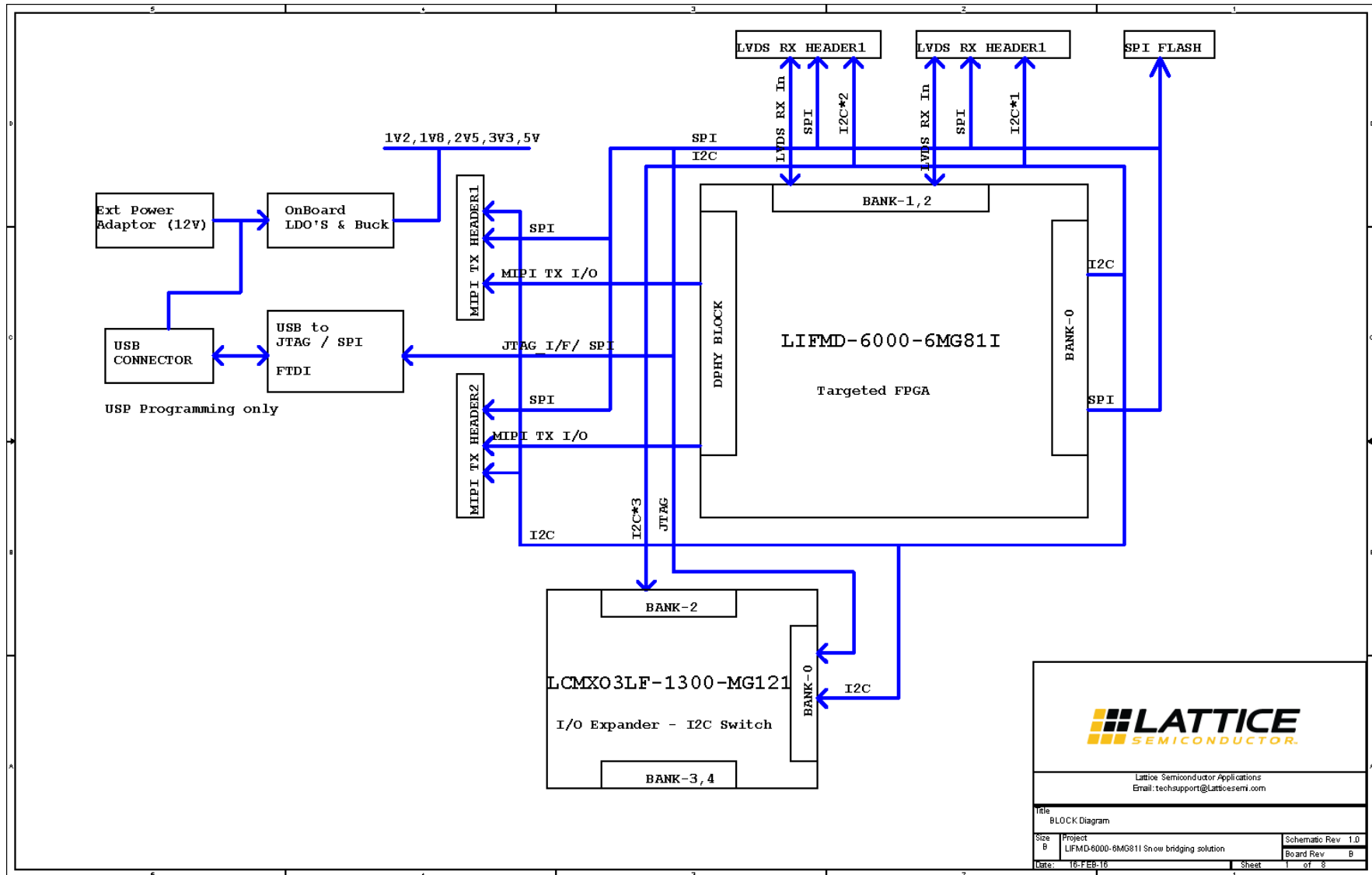

LIF-MD6000 Master Link Board Block Diagram

**LATTICE**  
SEMICONDUCTOR

Lattice Semiconductor Applications  
Email: techsupport@latticesemi.com

Title BLOCK Diagram		Schematic Rev 1.0	
Size B	Project LIFMD-6000-6MG81I Snow bridging solution	Board Rev 8	
Udate 16-FEB-16	Sheet 1 of 8		

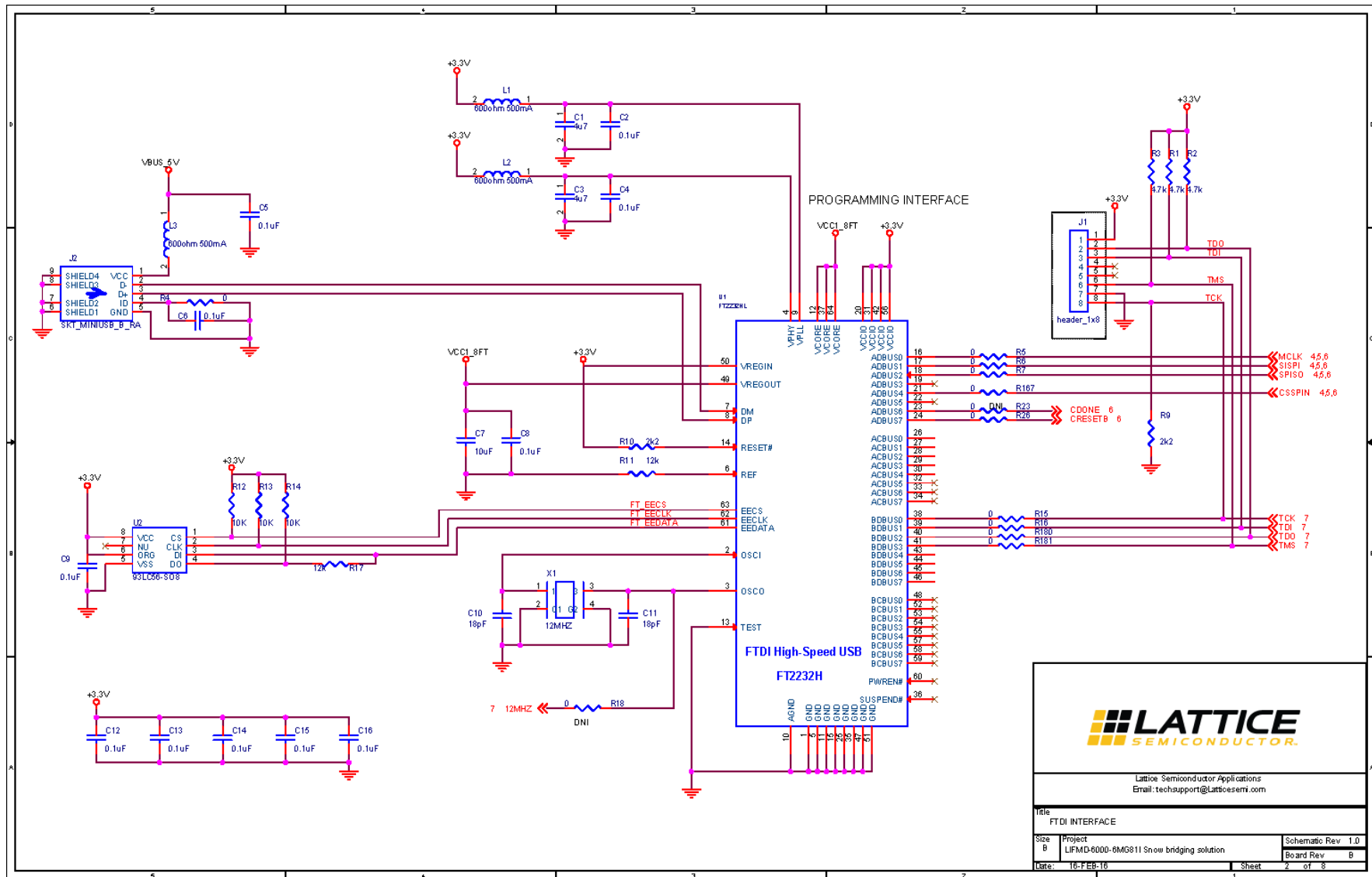

Lattice Semiconductor Applications  
Email: techsupport@latticesemi.com

Title FTDI INTERFACE		
Size B	Project LIFMD-6000-6MG811 Snow bridging solution	Schematic Rev 1.0
Date: 16.FEB.16		Board Rev B
Sheet 2		of 8

FTDI Interface

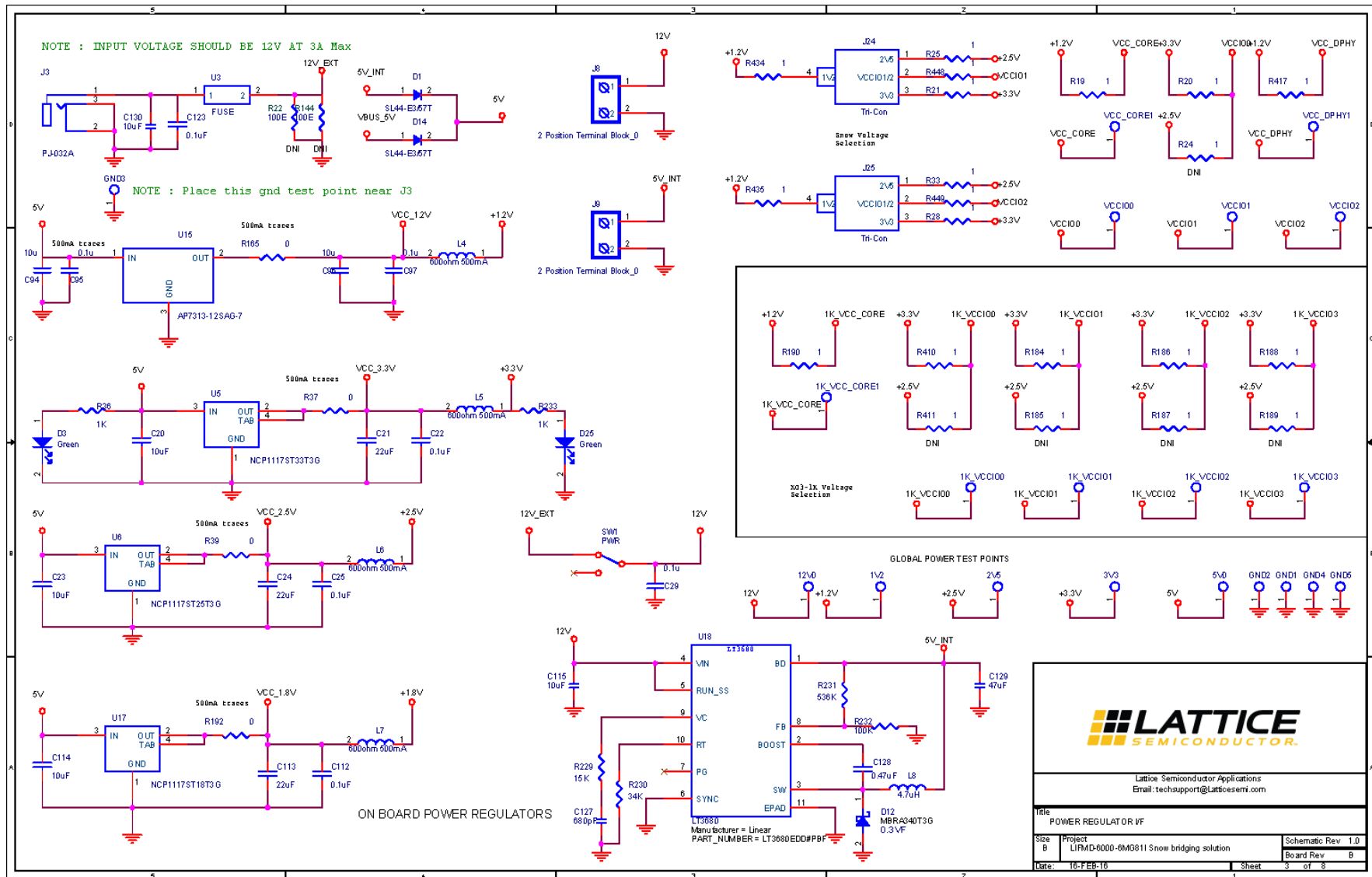

**Power Regulator Interface**

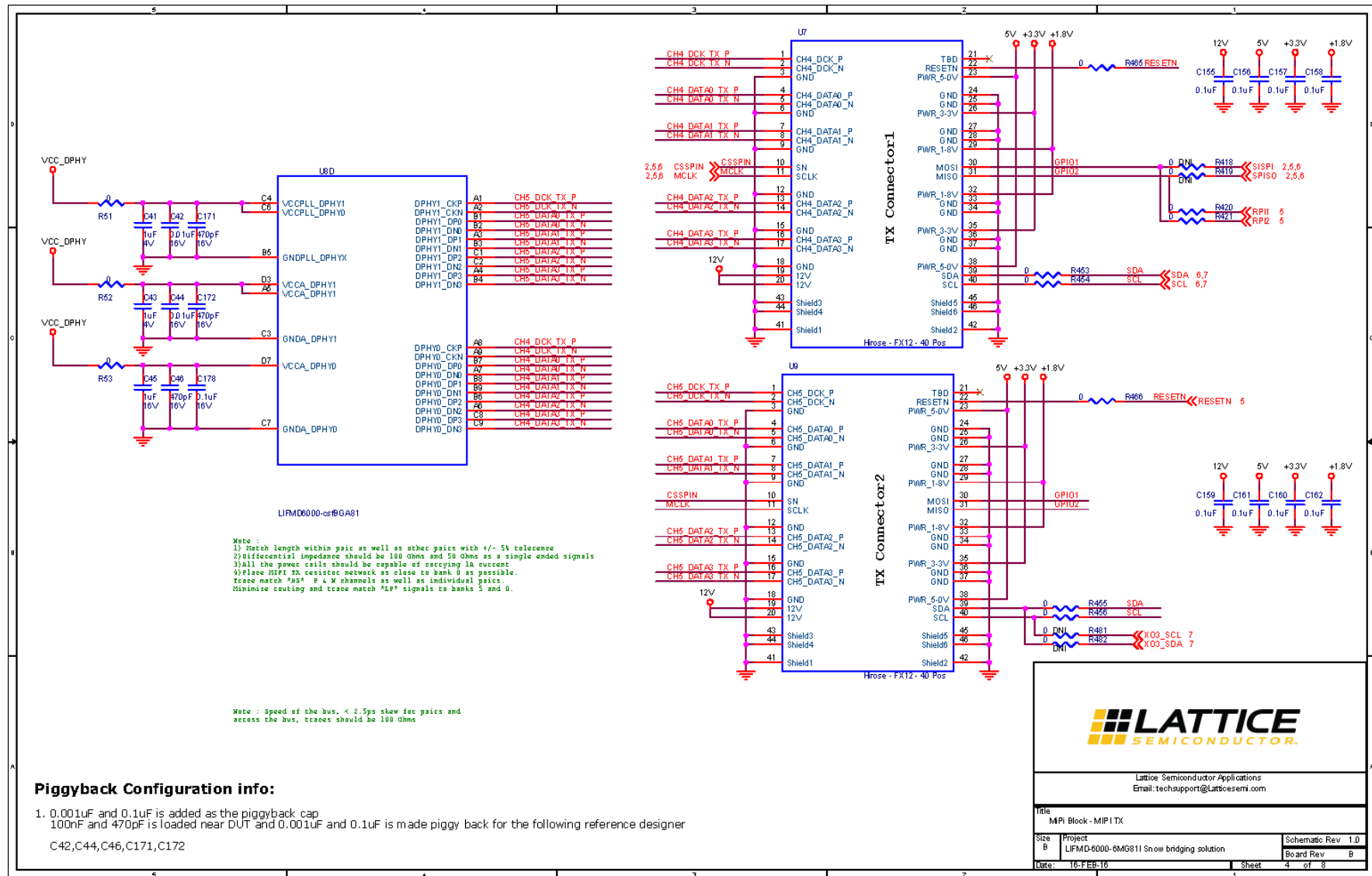

MIPI Block – MIPI Tx



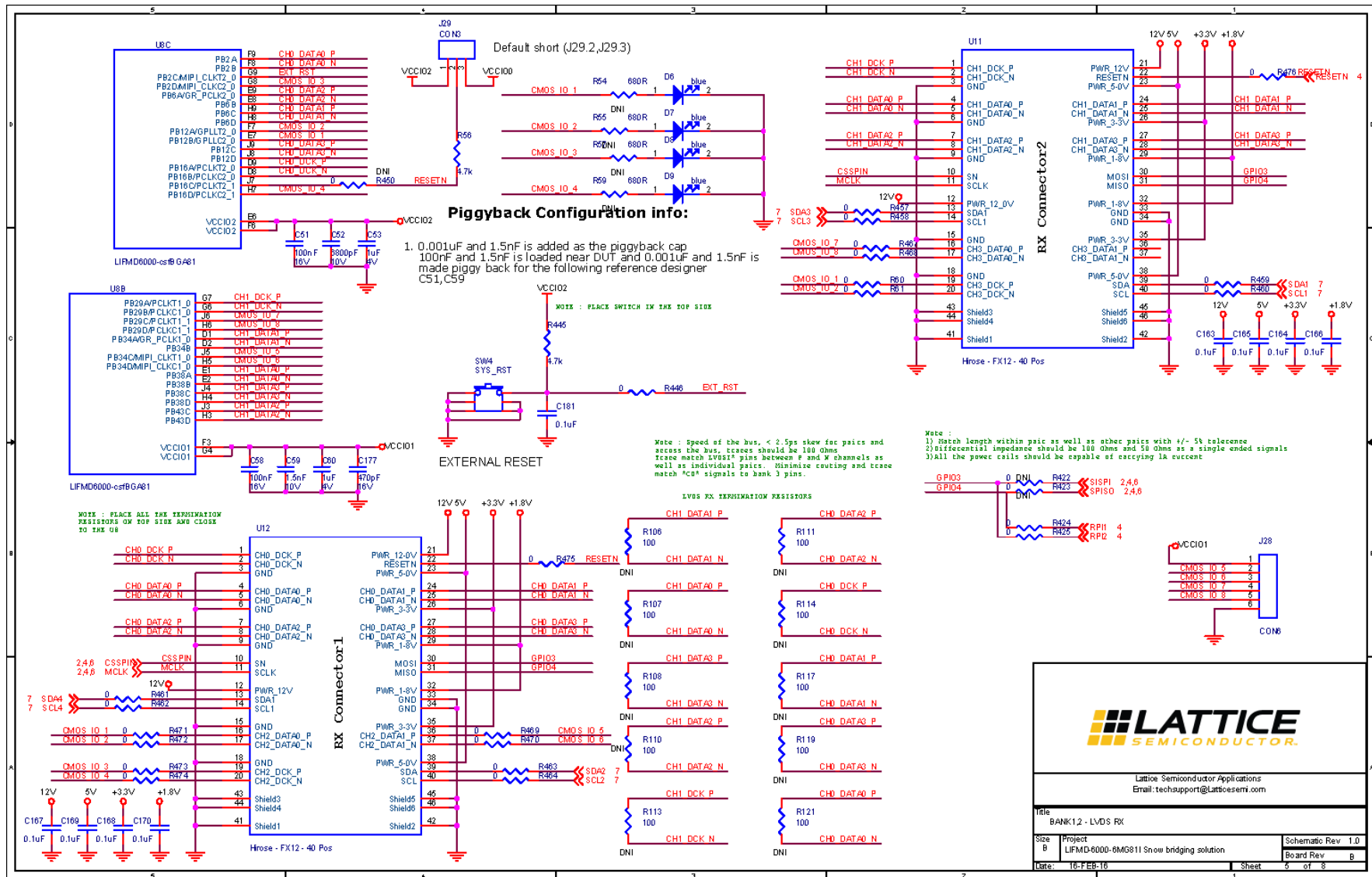

**Bank 1, 2 – LVDS Rx**

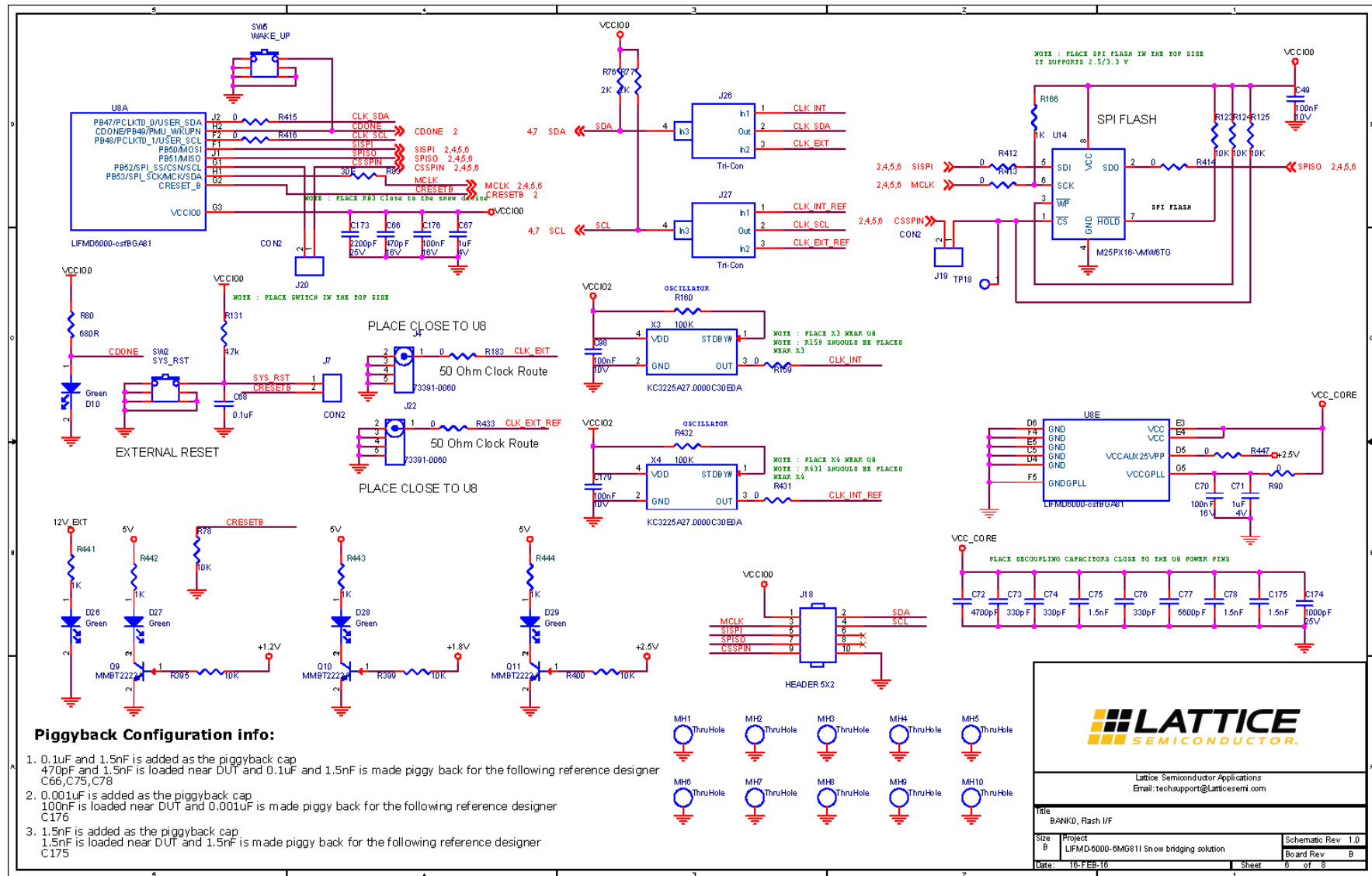

**BANK0, Flash Interface**



	5	4	3	2	1												
<p><b>Routing guidelines for MIPI &amp; LVDS</b> -----</p> <ol style="list-style-type: none"> <li>1) All differential routes are required to have the same length between the positive (true) and the negative (complimentary) routes. Spacing between the positive (true) and the negative (complimentary) shall be 2 times trace width.</li> <li>2) Target differential impedance shall be 100 Ohms</li> <li>3) Trace length matching to be within 1.0 mm (40 mil) across the entire bus.</li> <li>4) Use small humps for skew corrections</li> <li>5) Place signal vias close together and remove copper in between vias. Traces to be fully shielded with GND stitching terminating at both trace end points</li> <li>6) Board trace impedance results must be within <math>\pm 10</math> percent of target and Power plane impedance to be within <math>\pm 10</math> percent of target at operating frequency</li> </ol> <p><b>MIPI &amp; LVDS Simulation Requirement</b> -----</p> <ol style="list-style-type: none"> <li>1) MIPI Differential Mode insertion Loss shall be <math>&gt; -1.6</math> dB at 750 MHz</li> <li>2) MIPI Differential Mode Return Loss shall be <math>&lt; -15</math> dB at 750 MHz</li> <li>3) MIPI Common Mode Return Loss shall be <math>&lt; -15</math> dB at 750 MHz</li> <li>4) LVDS differential mode return loss shall be <math>&lt; -16.5</math> dB at 600 MHz</li> <li>5) LVDS common mode return loss shall be <math>&lt; -16.5</math> dB at 600 MHz</li> <li>6) LVDS insertion loss shall be <math>&gt; -1.7</math> dB at 600 MHz</li> <li>7) LVDS Cross coupling shall be <math>&lt; -22</math> dB for victim IO at 600 MHz</li> <li>8) Power plane impedance to be within <math>\pm 10</math> percent of target at operating frequency</li> </ol>	<div style="text-align: center;">  </div> <p style="text-align: center; font-size: small;">Lattice Semiconductor Applications Email: techsupport@latticesemi.com</p> <table border="1" style="width: 100%; border-collapse: collapse; font-size: x-small;"> <tr> <td colspan="2">Title Layout Guidelines</td> </tr> <tr> <td style="width: 50%;"> <table border="1" style="width: 100%; border-collapse: collapse;"> <tr> <td style="width: 20%;">Size B</td> <td style="width: 60%;">Project LIFMD-6000-6MG811 Snow bridging solution</td> <td style="width: 20%;">Schematic Rev 1.0</td> </tr> <tr> <td colspan="2">Date: 16.FEB.16</td> <td>Board Rev B</td> </tr> </table> </td> <td style="width: 50%; text-align: right;"> <table border="1" style="width: 100%; border-collapse: collapse;"> <tr> <td style="width: 50%;">Sheet 8</td> <td style="width: 50%;">of 8</td> </tr> </table> </td> </tr> </table>					Title Layout Guidelines		<table border="1" style="width: 100%; border-collapse: collapse;"> <tr> <td style="width: 20%;">Size B</td> <td style="width: 60%;">Project LIFMD-6000-6MG811 Snow bridging solution</td> <td style="width: 20%;">Schematic Rev 1.0</td> </tr> <tr> <td colspan="2">Date: 16.FEB.16</td> <td>Board Rev B</td> </tr> </table>	Size B	Project LIFMD-6000-6MG811 Snow bridging solution	Schematic Rev 1.0	Date: 16.FEB.16		Board Rev B	<table border="1" style="width: 100%; border-collapse: collapse;"> <tr> <td style="width: 50%;">Sheet 8</td> <td style="width: 50%;">of 8</td> </tr> </table>	Sheet 8	of 8
Title Layout Guidelines																	
<table border="1" style="width: 100%; border-collapse: collapse;"> <tr> <td style="width: 20%;">Size B</td> <td style="width: 60%;">Project LIFMD-6000-6MG811 Snow bridging solution</td> <td style="width: 20%;">Schematic Rev 1.0</td> </tr> <tr> <td colspan="2">Date: 16.FEB.16</td> <td>Board Rev B</td> </tr> </table>	Size B	Project LIFMD-6000-6MG811 Snow bridging solution	Schematic Rev 1.0	Date: 16.FEB.16		Board Rev B	<table border="1" style="width: 100%; border-collapse: collapse;"> <tr> <td style="width: 50%;">Sheet 8</td> <td style="width: 50%;">of 8</td> </tr> </table>	Sheet 8	of 8								
Size B	Project LIFMD-6000-6MG811 Snow bridging solution	Schematic Rev 1.0															
Date: 16.FEB.16		Board Rev B															
Sheet 8	of 8																
5	4	3	2	1													

### Layout Guidelines

## Appendix B. LIF-MD6000-ML-EVN-BRD Bill of Materials

### LIF-MD6000 Master Link Board Bill of Materials

Item	Reference	Quantity	Part	PCB Footprint	Comments	PART_NUMBER	Manufacturer	Description
1	C1, C3	2	4u7	C0603	—	ECJ-1VB0J475K	Panasonic	Cap Cer 4.7 uF 6.3 V 10% X5R 0603
2	C2, C4, C5, C6, C8, C9, C12, C13, C14, C15, C16, C22, C25, C68, C112, C180, C181	17	0.1 uF	C0402	—	C0402C104K4 RACTU	Kemet	CAP CERAMIC 0.1 uF 16 V X7R 0402
3	C7, C20, C23, C107, C114, C141, C145, C150, C153	9	10 uF	C0603	—	LMK107BJ106 MALTD	Taiyo Yuden	CAP CECAP CER 10 uF 10 V X5R 20% 0603
4	C10, C11	2	18 pF	C0402	—	C0402C180K3 GACTU	Kemet	CAP CER 18 pF 25 V C0G 0402
5	C21, C24, C113	3	22 uF	C0805	—	LMK212BJ226 MG-T	Taiyo Yuden	CAP CERAMIC 22 uF 10 V X5R 0805
6	C29, C95, C97	3	0.1 uF	C0402	—	CL05A104MP 5NNNC	Samsung	Cap Ceramic 0.1 uF 10 V X5R 20% SMD 0402 85C Paper T/R
7	C41, C43, C53, C60, C67, C71	6	1 uF	C0306	—	LLR185C70G1 05ME05L	Murata	CAP CER 1uF 4 V X7S 0306
8	C42, C44	2	0.01 uF	C0201	—	GRM033R61C 103KA12D	Murata	CAP CER 10000 pF 16 V X5R 0201
9	C42, C44, C51, C176	4	0.001 uF	C0201	Piggyback Configuration	GRM033R71C 102KA01D	Murata	CAP CER 1000 pF 16 V X7R 0201
10	C45	1	1 uF	C0402	—	GRM155R61C 105KA12D	Murata	CAP CER 1 uF 16 V X5R 0402
11	C46, C66, C171, C172, C177	5	470 pF	C0201	—	GRM033R71C 471KA01D	Murata	CAP CER 470 pF 16 V X7R 0201
12	C46, C66, C171, C172	4	0.1 uF	C0201	Piggyback Configuration	GRM033R61C 104KE84D	Murata	CAP CER 0.1 uF 16 V X5R 0201
13	C49, C98, C179	3	100 nF	C0402	—	GRM155R61A 104KA01D	Murata	CAP CER 100 nF 10 V 10% X5R 0402
14	C51, C58, C70, C176	4	100 nF	C0201	—	C0603X5R1C1 04K030BC	TDK	CAP CER 0.1 uF 16 V X5R 0201
15	C52	1	6800 pF	C0201	—	GRM033R71A 682KA01D	Murata	CAP CER 6800 pF 10 V X7R 0201
16	C59, C75, C78, C175	4	1.5 nF	C0201	—	GRM033R71A 152KA01D	Murata	CAP CER 1500 pF 10 V X7R 0201
17	C75, C78, C59, C175	4	1.5 nF	C0201	Piggyback Configuration	GRM033R71A 152KA01D	Murata	CAP CER 1500 pF 10 V X7R 0201
18	C72	1	4700 pF	C0306	—	LLL185R71H4 72MA01L	Murata	CAP CER 4700 pF 50 V X7R 0306
19	C73, C74, C76	3	330 pF	C0201	—	GRM033R71H 331KA12D	Murata	CAP CER 330 pF 50 V X7R 0201
20	C77	1	5600 pF	C0201	—	GRM033R71A 562KA01D	Murata	CAP CER 5600 pF 10 V X7R 0201

LIF-MD6000 Master Link Board Bill of Materials (Continued)

Item	Reference	Quantity	Part	PCB Footprint	Comments	PART_NUMBER	Manufacturer	Description
21	C94, C96	2	10 uF	C0603	—	CL10X106MP8NRNC	Samsung	CAP CER 10 uF 10 V 20% X6S 0603
22	C102, C104, C105, C139, C142, C143, C144, C147, C148, C151, C152	11	0.1 uF	C0201	---	C0603X5R1C104K030BC	TDK	CAP CER 0.1 uF 16 V 10% X5R 0201
23	C103, C140, C146, C149, C154	5	0.01 uF	C0201	—	CC0201KRX7R7BB103	Yageo	CAP CER 10000 pF 16 V 10% X7R 0201
24	C106	1	1 uF	C0402	—	C0402C105K9PACTU	Kemet	CAP CERAMIC 1 uF 6.3 V X5R 0402
25	C115, C130	2	10 uF	C0603	—	CL10A106MA8NRNC	Samsung	CAP CER 10 uF 25 V 20% X5R 0603
26	C123	1	0.1 uF	C0603	—	GRM188R71E104KA01D	Murata	CAP CER 0.1 uF 25 V 10% X7R 0603
27	C127	1	680 pF	C0603	—	C0603C681J3GACTU	Kemet	CAP CER 680 pF 25 V 5% NP0 0603
28	C128	1	0.47 uF	C0402	—	CL05A474KA5NNNC	Samsung	CAP CER 0.47 uF 25 V 10% X5R 0402
29	C129	1	47 uF	C0805	—	C2012X5R1A476M125AC	TDK	CAP CER 47 uF 10 V 20% X5R 0805
30	C155, C156, C157, C158, C159, C160, C161, C162, C163, C164, C165, C166, C167, C168, C169, C170	16	0.1 uF	C0402	—	04023C104KA T2A	AVX	CAP CER 0.1 uF 25 V 10% X7R 0402
31	C173	1	2200 pF	C0201	—	GRM033R71E222KA12D	Murata	CAP CER 2200 pF 25 V X7R 0201
32	C174	1	1000 pF	C0201	—	GRM033R61E102KA01D	Murata	CAP CER 1000 pF 25 V X5R 0201
33	C178	1	0.1 uF	C0201	—	GRM033R61C104KE84D	Murata	CAP CER 0.1 uF 16 V X5R 0201
34	D1, D14	2	SL44-E3/ 57T	SL44E357T	—	SL44-E3/57T	Vishay semiconductor	Schottky Diodes & Rectifiers 4.0 A 40 V
35	D3, D25, D26, D27, D28, D29	6	Green	led_0603	—	LTST-C190KGKT	LITE-On INC	LED SUPER GREEN CLEAR 0603 SMD
36	D6, D7, D8, D9, D30, D31, D32, D33	8	blue	led_0603	—	LTST-C193TBKT-5A	LITE-On INC	Standard LEDs - SMD Blue 470 nm 28mcd 5 mA
37	D10	1	Green	led_0603	—	LG L29K-G2J1-24-Z	OSRAM	LED SUPER GREEN CLEAR 0603 SMD
38	D12	1	0.3 VF	MBRA340T 3G	—	MBRA340T3G	ON Semi	DIODE SCHOTTKY 40 V 3 A SMA
39	D23	1	Red	led_0603	—	LTST-C193KRKT-5A	LITE-On INC	Standard LEDs - SMD Red 631 nm 14mcd 5 mA

LIF-MD6000 Master Link Board Bill of Materials (Continued)

Item	Reference	Quantity	Part	PCB Footprint	Comments	PART_NUMBER	Manufacturer	Description
40	VCC_DPHY1, VCC_CORE1, VCCIO1, GND1, VCCIO2, GND2, GND3, GND4, GND5, 1K_VCCIO0, 1K_VCC_CORE1, 1K_VCCIO1, 1V2, 1K_VCCIO2, 1K_VCCIO3, TP18, TP23, TP24, TP25, 2V5, 3V3, 5V0, 12V0, VCCIO0	24	TP_S_40_63	tp_s_40_63	DNI	—	—	Square test point, 40 mil inner diameter, 63 mil outer diameter
41	J1	1	header_1x8	hdr_amp_87220_8_1x8_100	—	22-28-4081	Molex	CONN HEADER 8POS .100 VERT TIN
42	J2	1	SKT_MINI_USB_B_RA	skt_miniau_sb_b_ra	—	5075BMR-05-SM-CR	Neltron	CONN MINI USB RCPT RA TYPE B SMD
43	J3	1	PJ-032A	PJ-032A	—	PJ-032A	CUI Inc.	CON PWR JCK 2.0 X 6.5 M VERT
44	J4, J22	2	73391-0060	73391-0060	—	73391-0060	Molex	CONN SMA JACK STR 50 OHM PCB
45	J7, J19, J20	3	CON2	CON2	REGULAR 100 MIL HEADER	—	—	General 100 mils 2 Position header
46	J8, J9	2	2 Position Terminal Block_0	TERM_BLOCK_2POS_10A	—	1727010	Phoenix Contact	TERM BLOCK 2POS 3.81 mm PCB GRN
47	J18	1	HEADER 5X2	HEADER 2X5	REGULAR 100 MIL HEADER	—	—	General 100 Mils 2*5 header
48	J23	1	4 HEADER	CON4	REGULAR 100 MIL HEADER	—	—	General 100 Mils 4 Position Header
49	J24, J25, J26, J27	4	Tri-Con	TriCon	REGULAR 100 MIL HEADER	—	—	General 100 Mils Header
50	J28	1	CON6	HDR1X6	REGULAR 100 MIL HEADER	—	—	—
51	J29	1	CON3	HDR1X3	REGULAR 100 MIL HEADER	—	—	—
52	L1, L2, L3, L4, L5, L6, L7	7	600 Ω 500 mA	FB0603	—	BLM18AG601 SN1D	Murata	Ferrite Bead 600 Ω @100 MHz 500 mA 0603
53	L8	1	4.7 uH	MPLC0730 L4R7	—	MPLC0730L4R7	Kemet	INDUCTOR POWER 4.7 uH 20% SMD
54	MH1, MH2, MH3, MH4, MH5, MH6, MH7, MH8, MH9, MH10	10	Thru Hole	MTG125	DNL	—	—	—

LIF-MD6000 Master Link Board Bill of Materials (Continued)

Item	Reference	Quantity	Part	PCB Footprint	Comments	PART_NUMBER	Manufacturer	Description
55	Q9, Q10, Q11	3	MMBT2222A	SM_SOT23-3	—	MMBT2222A,215	NXP Semiconductor	TRANS NPN 40 V 0.6 A SOT23
56	R1, R2, R3, R56, R131, R175, R176, R177, R178, R403, R404, R405, R440, R445, R477, R478, R479, R480, R483, R484	20	4.7K	R0603	—	CRCW06034K70FKEA	Vishay	RES SMD 4.7 kΩ HM 1% 1/10 W 0603
57	R4, R5, R6, R7, R15, R16, R26, R37, R39, R51, R52, R53, R90, R159, R165, R167, R180, R181, R183, R192, R431, R433, R447	23	0	R0603	—	RC0603JR-070RL	Yageo	Res 1/10 W 0.0 Ω 5% 0603
58	R9, R10	2	2K2	R0603	—	CRCW06032K20FKEA	Vishay	RES SMD 2.2 kΩ 1% 1/10 W 0603
59	R11, R17	2	12K	R0603	—	RC0603FR-0712KL	Yageo	RES SMD 12 kΩ 1% 1/10 W 0603
60	R12, R13, R14, R123, R124, R125	6	10K	R0603	—	RMCF0603JT10K0	Stackpole Electronics Inc	RES SMD 10 kΩ 5% 1/10 W 0603
61	R18, R418, R419, R422, R423	5	0	R0603	DNI	RC0603JR-070RL	Yageo	Res 1/10 W 0.0 Ω 5% 0603
62	R19, R20, R21, R25, R28, R33, R184, R186, R188, R190, R410, R417, R434, R435, R448, R449	16	1	R0603	—	CRCW06031R00JNEAHP	Vishay/Dale	RES SMD 1 Ω 5% 1/4W 0603
63	R22, R144	2	100E	R0603	DNI	CRCW0603100RFKEAHP	Vishay / Dale	RES SMD 100 Ω 1% 1/4W 0603
64	R23	1	0	R0603	DNI	RC0603JR-070RL	Yageo	Res 1/10 W 0.0 Ω 5% 0603
65	R24, R185, R187, R189, R411	5	1	R0603	DNI	CRCW06031R00JNEAHP	Vishay/Dale	RES SMD 1 Ω 5% 1/4W 0603
66	R36, R233	2	1K	R0603	—	RC0603FR-071KL	Yageo	RES SMD 1 kΩ 1% 1/10 W 0603
67	R54, R55, R57, R59	4	680R	R0402	DNI	RMCF0402JT680R	Stackpole Electronics Inc	RES 680 Ω 1/16 W 5% 0402
68	R60, R61, R446, R457, R458, R459, R460, R461, R462, R463, R464, R467, R468, R469, R470, R471, R472, R473, R474, R475, R476	21	0	R0402	—	RC0402JR-070RL	Yageo	RES SMD 0.00 HM JUMPER 1/16 W 0402



LIF-MD6000 Master Link Board Bill of Materials (Continued)

Item	Reference	Quantity	Part	PCB Footprint	Comments	PART_NUMBER	Manufacturer	Description
69	R76, R77	2	2K	R0402	—	ERJ-2RKF2001X	Panasonic	RES SMD 2 kΩ 1% 1/10 W 0402
70	R78	1	10K	R0402	—	RMCF0402JT10K0	Stackpole Electronics Inc	RES 10 kΩ 1/16 W 5% 0402
71	R80, R436, R437, R438, R439	5	680R	R0402	—	RMCF0402JT680R	Stackpole Electronics Inc	RES 680 Ω 1/16 W 5% 0402
72	R83	1	30E	R0603	—	RC0603FR-0730RL	Yageo	RES SMD 30 Ω 1% 1/10 W 0603
73	R106, R107, R108, R110, R111, R113, R114, R117, R119, R121	10	100	R0402	DNI	RC0402FR-07100RL	Yageo	RES SMD 100 Ω 1% 1/16 W 0402
74	R160, R432	2	100K	R0402	—	RMCF0402JT100K	Stackpole Electronics Inc	RES 100 kΩ 1/16 W 5% 0402
75	R166, R441, R442, R443, R444	5	1K	R0402	—	RMCF0402JT1K00	Stackpole Electronics Inc	RES 1 kΩ 1/16 W 5% 0402
76	R179	1	650	R0603	—	RC0603FR-07649RL	Yageo	RES SMD 649 Ω 1% 1/10 W 0603
77	R229	1	15K	R0402	—	ERJ-2RKF1502X	Panasonic	RES 15 kΩ 1/10 W 1% 0402 SMD
78	R230	1	34K	R0402	—	ERJ-2RKF3402X	Panasonic	RES 34 kΩ 1/10 W 1% 0402 SMD
79	R231	1	536K	R0402	—	ERJ-2RKF5363X	Panasonic Electronic Components	RES 536 kΩ 1/10 W 1% 0402 SMD
80	R232	1	100K	R0402	—	ERJ-2RKF1003X	Panasonic Electronic Components	RES 100 kΩ 1/10 W 1% 0402 SMD
81	R395, R399, R400	3	10K	R0603	—	ERJ-3EKF1002V	Panasonic	RES SMD 10 kΩ 1% 1/10 W 0603
82	R412, R413, R414, R415, R416, R420, R421, R424, R425, R451, R452, R453, R454, R455, R456, R465, R466	17	0	R0603	—	RC0603JR-070RL	Yageo	Res 1/10 W 0.0 Ω 5% 0603
83	R450	1	0	R0402	DNI	RC0402JR-070RL	Yageo	RES SMD 0.00 HM JUMPER 1/16 W 0402
84	R481, R482	2	0	R0603	DNL	RC0603JR-070RL	Yageo	Res 1/10 W 0.0 Ω 5% 0603
85	SW1	1	PWR	TS01CQE_switch	—	TS01CQE	C&K Components	SWITCH SLIDE SPDT 3 A 120 V

LIF-MD6000 Master Link Board Bill of Materials (Continued)

Item	Reference	Quantity	Part	PCB Footprint	Comments	PART_NUMBER	Manufacturer	Description
86	SW2, SW3, SW4	3	SYS_RST	2psmd_eswitch	—	TL1015AF160QG	E-Switch	SWITCH TACTILE SPST-NO 0.05 A 12 V
87	SW5	1	WAKE_UP	2psmd_eswitch	—	TL1015AF160QG	E-Switch	SWITCH TACTILE SPST-NO 0.05 A 12 V
88	U1	1	FT2232HL	tqfp64_0p5_12p2x12p2_h1p6	—	FT2232HL	FTDI	USB to UART / FIFO
89	U2	1	93LC56-SO8	so8_50_244	—	93LC56C-I/SN	Microchip	IC 93LC56 EEPROM
90	U3	1	FUSE	0154004DRT	—	0154004.DRT	Littlefuse	Surface Mount Fuses Fuseblock with fuse 4A OMNI BLOK 154T
91	U5	1	NCP1117ST33T3G	sot223_4p	—	NCP1117ST33T3G	On Semi	IC Reg LDO 3.3 V SOT-223
92	U6	1	NCP1117ST25T3G	sot223_4p	—	NCP1117ST25T3G	On Semi	IC Reg LDO 2.5 V SOT-223
93	U7, U9, U11, U12	4	Hirose - FX12 - 40 Pos	Hirose-FX12	—	FX12B-40P-0.4SV	Hirose Electric Co Ltd	Conn Board to Board PL 40 POS 0.4 mm Solder ST SMD T/R
94	U8	1	LIF-MD6000-csfBGA81	LIF-MD6000-csfBGA81	Customer supplied	LIF-MD6000-csfBGA81	Lattice Semiconductor	Lattice Semiconductor 6K CrossLink FPGA Family
95	U14	1	M25PX16-VMW6TG	SOIC8	—	M25PX16-VMW6TG	Micron Technology Inc	IC FLASH 16 Mbit 75 MHz 8SO
96	U15	1	AP7313-12SAG-7	SOT23	—	AP7313-12SAG-7	Diodes Inc	LDO Voltage Regulators LDO SOT-23R 1.2 V/ 150 mA
97	U17	1	NCP1117ST18T3G	sot223_4p	—	NCP1117ST18T3G	On Semi	IC Reg LDO 1.8 V SOT-223
98	U18	1	LT3680	LT3680_10QFN	—	LT3680EDD#PBF	Linear	5 V Step down converter
99	U19	1	LCMXO3LF-1200E-MG121	LCMXO3LF-1200E-MG121	Customer supplied	LCMXO3LF-1200E-MG121	Lattice Semiconductor	CPLD MachXO3 Family 121-Pin CSFBGA-0.5 mm Pitch
100	X1	1	12MHZ	crystal_4p3p2x2p5	—	7M-12.000MAAJ-T	TXC	12 MHz Crystal
101	X3, X4	2	KC3225A27.0000C30E0A	27MHZ_OSC	—	KC3225A27.0000C30E0A	AVX Corporation	Standard Clock Oscillators 27.000 MHz
102	LIF-MD6000 MASTER LINK BOARD PCB	1	—	—	—	305-PD-16-0154	PACTRON	—

## Appendix C. SMA-IOL-EVN-BRD Schematics

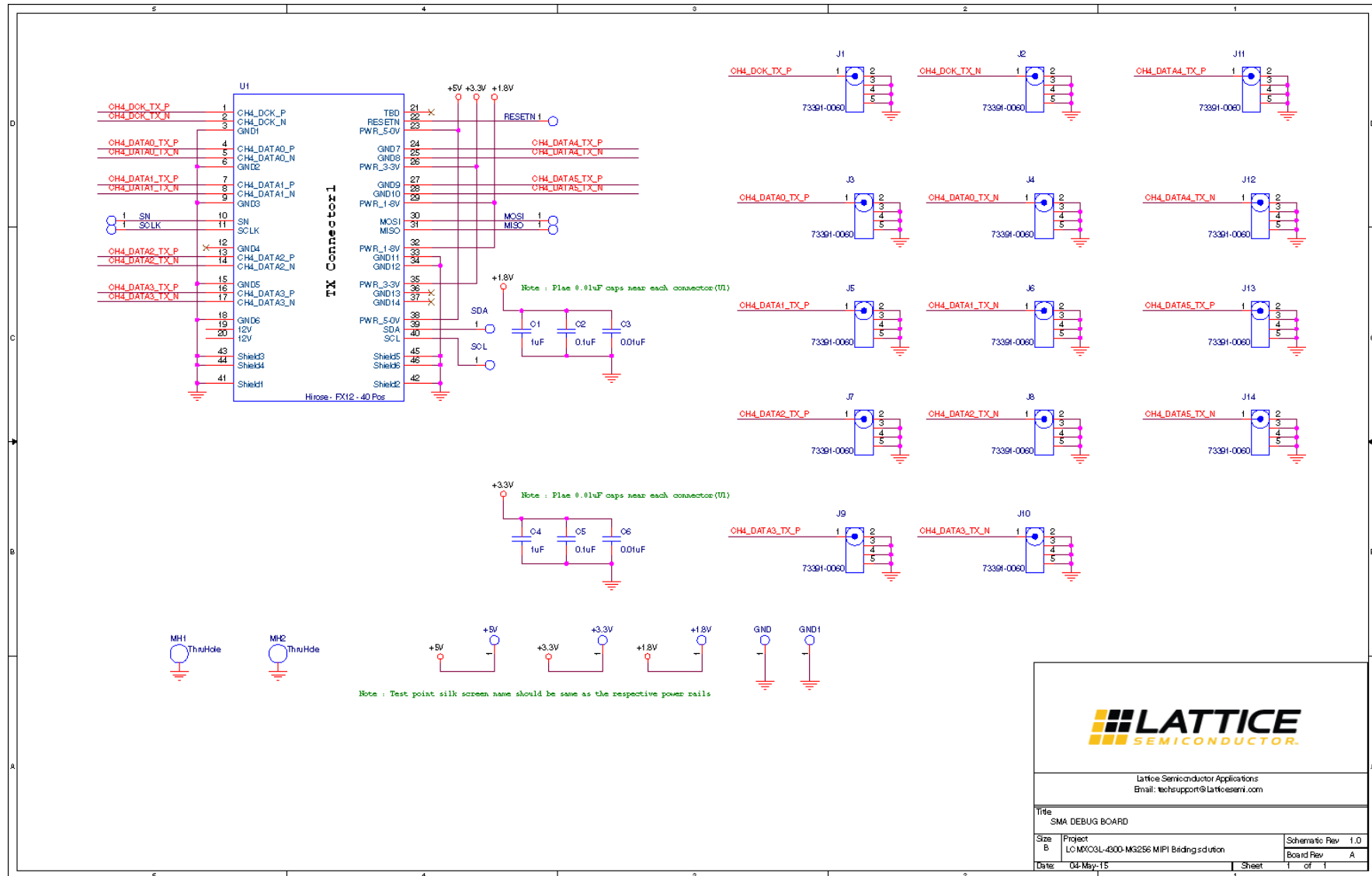

SMA Debug Board

**LATTICE**  
SEMICONDUCTOR

Lattice Semiconductor Applications  
Email: techsupport@latticesemi.com

Title: SMA DEBUG BOARD

Size B	Project: LCMXO3L-4300-M3256 MIPI Bridging solution	Schematic Rev: 1.0
Date: 04-May-15	Board Rev: A	

Sheet 1 of 1

## Appendix D. SMA-IOL-EVN-BRD Bill of Materials

### SMA IOLink Board Bill of Materials

Item	Reference	Quantity	Part	PCB Footprint	Comments	PART_NUMBER	Manufacturer	Description
1	GND1, +5 V, +1.8 V, +3.3 V, SN, SDA, SCLK, SCL, RESETN, MOSI, MISO, GND	12	TP_S_40_63	tp_s_40_63	DNI	—	—	Square test point, 40 mil inner diameter, 63 mil outer diameter
2	C1, C4	2	1 uF	C0402	—	C0402C105K9PACTU	Kemet	CAP CERAMIC 1 uF 6.3 V X5R 0402
3	C2, C5	2	0.1 uF	C0402	—	C0402C104K4RACTU	Kemet	CAP CERAMIC 0.1 uF 16 V X7R 0402
4	C3, C6	2	0.01 uF	C0402	—	C0402C103J4RACTU	Kemet	CAP CERAMIC 10 nF 16 V 5% X7R 0402
5	J1, J2, J3, J4, J5, J6, J7, J8, J9, J10, J11, J12, J13, J14	14	73391-0060	73391-0060	—	73391-0060	Molex	Molex Straight 500 Through Hole SMA Connector, jack, Solder Termination
6	MH1, MH2	2	Thru Hole	MTG125	—	—	—	—
7	U1	1	Hirose - FX12 - 40 Pos	Hirose-FX12S	—	FX12B-40S-0.4SV	Hirose Electric Co Ltd	Conn Board to Board PL 40 POS 0.4 mm Solder ST SMD T/R
8	SMA IOLINK BOARD PCB	1	—	—	—	305-PD-15-0589	PACTRON	—

## Appendix E. B-IOL-EVN-BRD Schematics

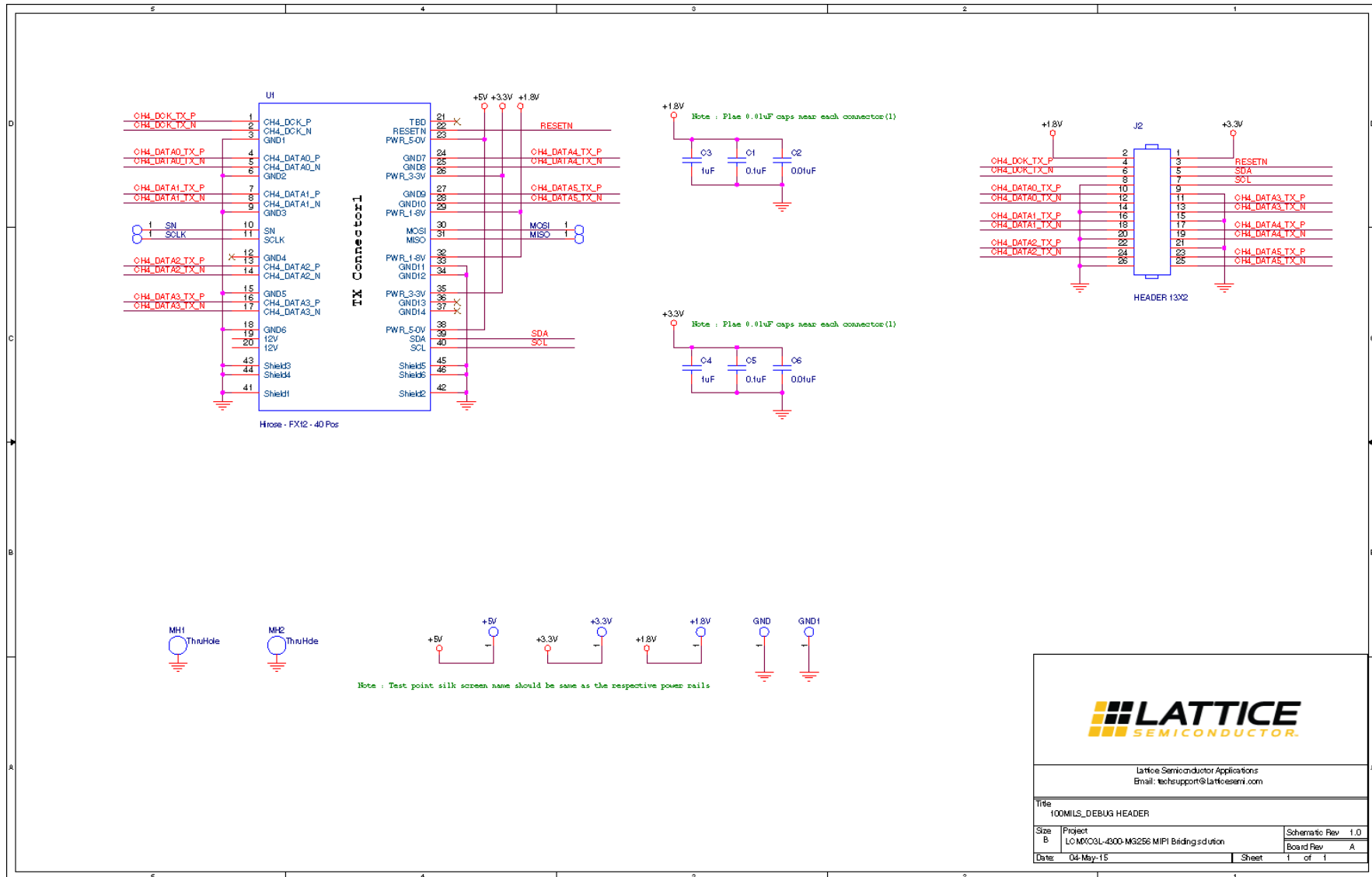

100MILS\_DEBUG Header

**LATTICE**  
SEMICONDUCTOR

Lattice Semiconductor Applications  
Email: techsupport@latticesemi.com

Title	
100MILS_DEBUG HEADER	
Size B	Project
Date	Board Rev
04-May-15	A
Sheet	1 of 1

## Appendix F. B-IOL-EVN-BRD Bill of Materials

### Breakout IOLink Board Bill of Materials

Item	Reference	Quantity	Part	PCB Footprint	Comments	PART_NUMBER	Manufacturer	Description
1	GND1, +5 V, +1.8 V, +3.3 V, SN, SCLK, MOSI, MISO, GND	9	TP_S_40_63	tp_s_40_63	DNL	—	—	Square test point, 40 mil inner diameter, 63 mil outer diameter
2	C1, C5	2	0.1uF	C0402	—	C0402C104K4RACTU	Kemet	CAP CERAMIC 0.1 uF 16 V X7R 0402
3	C2, C6	2	0.01uF	C0402	—	C0402C103J4RACTU	Kemet	CAP CERAMIC 10 nF 16 V 5% X7R 0402
4	C3, C4	2	1uF	C0402	—	C0402C105K9PACTU	Kemet	CAP CERAMIC 1 uF 6.3 V X5R 0402
5	J2	1	HEADER 13X2	13X2_HDR	REGULAR 100 MIL HEADER	—	—	—
6	MH1, MH2	2	ThruHole	MTG125	DNL	—	—	—
7	U1	1	Hirose - FX12 - 40 Pos	Hirose-FX12S	—	FX12B-40S-0.4SV	Hirose Electric Co Ltd	Conn Board to Board PL 40 POS 0.4 mm Solder ST SMD T/R
8	BREAKOUT IOLINK BOARD PCB	1	—	—	—	305-PD-15-0595	PACTRON	—

## Revision History

Date	Version	Change Summary
May 2016	1.0	Initial release.



7<sup>th</sup> Floor, 111 SW 5<sup>th</sup> Avenue  
Portland, OR 97204, USA  
T 503.268.8000  
[www.latticesemi.com](http://www.latticesemi.com)



Компания «Life Electronics» занимается поставками электронных компонентов импортного и отечественного производства от производителей и со складов крупных дистрибьюторов Европы, Америки и Азии.

С конца 2013 года компания активно расширяет линейку поставок компонентов по направлению коаксиальный кабель, кварцевые генераторы и конденсаторы (керамические, пленочные, электролитические), за счёт заключения дистрибьюторских договоров

Мы предлагаем:

- Конкурентоспособные цены и скидки постоянным клиентам.
- Специальные условия для постоянных клиентов.
- Подбор аналогов.
- Поставку компонентов в любых объемах, удовлетворяющих вашим потребностям.
- Приемлемые сроки поставки, возможна ускоренная поставка.
- Доставку товара в любую точку России и стран СНГ.
- Комплексную поставку.
- Работу по проектам и поставку образцов.
- Формирование склада под заказчика.
- Сертификаты соответствия на поставляемую продукцию (по желанию клиента).
- Тестирование поставляемой продукции.
- Поставку компонентов, требующих военную и космическую приемку.
- Входной контроль качества.
- Наличие сертификата ISO.

В составе нашей компании организован Конструкторский отдел, призванный помогать разработчикам, и инженерам.

Конструкторский отдел помогает осуществить:

- Регистрацию проекта у производителя компонентов.
- Техническую поддержку проекта.
- Защиту от снятия компонента с производства.
- Оценку стоимости проекта по компонентам.
- Изготовление тестовой платы монтаж и пусконаладочные работы.



Тел: +7 (812) 336 43 04 (многоканальный)

Email: [org@lifeelectronics.ru](mailto:org@lifeelectronics.ru)