

S32R372

S32R372 Data Sheet

Features

- Dual issue computation cores: Power Architecture® e200z7 32-bit CPU
- 1.3 MB on-chip code flash memory (FMC flash memory) with ECC
- 1 MB on-chip SRAM with ECC
- RADAR processing
 - Signal Processing Toolbox (SPT) for RADAR signal processing acceleration
 - Cross Triggering Engine (CTE) for precise timing generation and triggering
 - MIPICSI2 interface to connect external RADAR RX ADCs
- Memory protection
 - Each core memory protection unit provides 24 entries
 - Data and instruction bus system memory protection unit (SMPU) with 16 region descriptors each
 - Register protection
- Clock generation
 - 40 MHz external crystal (XOSC)
 - 16 MHz Internal oscillator (IRCOSC)
 - Dual system PLL with one frequency modulated phase-locked loop (FMPLL)
 - Low-jitter PLL
- Functional safety
 - Enables ASIL-B applications
 - Fault Collection and Control Unit (FCCU) for fault collection and fault handling
 - Memory Error Management Unit (MEMU) for memory error management
 - Safe eDMA controller
 - Self-Test Control Unit (STCU2)
 - Error Injection Module (EIM)
 - On-chip voltage monitoring
 - Clock Monitor Unit (CMU)
- Security
 - Cryptographic Security Engine (CSE2)
 - Supports censorship and life-cycle management
- Timers
 - Two Periodic Interval Timers (PIT) with 32-bit counter resolution
 - Two System Timer Module (STM)
 - Two Software Watchdog Timers (SWT)
 - One eTimer module with 6 channels each
 - One FlexPWM module for 12 PWM signals
- Communication interfaces
 - Two Serial Peripheral interface (SPI) modules
 - One LINFlexD module
 - Two inter-IC communication interface (I2C) modules
 - Two FlexCAN modules supporting CAN FD with configurable buffers
- Debug functionality
 - 4-pin JTAG interface and Nexus/Aurora interface for serial high-speed tracing
 - e200z7 core: Nexus development interface (NDI) per IEEE-ISTO 5001-2012 Class 3+
- Two analog-to-digital converters (SAR ADC)
 - Each ADC supports up to 16 input channels
 - Cross Trigger Unit (CTU)
- On-chip voltage DC/DC regulator for core supply generation (VREG)
- Two Temperature Sensors (TSENS)

Table of Contents

1	Introduction.....	3	8.3	Flash memory module life specifications.....	31
1.1	Chip comparison.....	3	8.4	Data retention vs program/erase cycles.....	32
1.2	Feature list.....	4	8.5	Flash memory AC timing specifications.....	32
1.3	Block diagram.....	8	8.6	Flash memory read wait-state and address-pipeline control settings.....	33
2	Ordering parts.....	9	9	Communication modules.....	34
2.1	Determining valid orderable parts.....	9	9.1	SPI timing specifications.....	34
3	Part identification.....	9	9.2	LINFlexD timing specifications.....	39
3.1	Description.....	9	9.3	I2C timing	39
3.2	Format.....	9	10	Debug modules.....	40
3.3	Fields.....	9	10.1	JTAG/CJTAG interface timing	40
4	General.....	11	10.2	Nexus Aurora debug port timing.....	43
4.1	Introduction.....	11	11	WKPU/NMI timing specifications.....	44
4.2	Absolute maximum ratings.....	11	12	External interrupt timing (IRQ pin).....	45
4.3	Operating conditions.....	13	13	Temperature sensor electrical characteristics.....	45
4.4	Supply current characteristics.....	14	14	Radar module.....	46
4.5	Voltage regulator electrical characteristics.....	15	14.1	MIPICSI2 D-PHY electrical and timing specifications.....	46
4.6	Electromagnetic Compatibility (EMC) specifications.....	19	14.2	MIPICSI2 disclaimer.....	49
4.7	Electrostatic discharge (ESD) characteristics.....	19	15	Thermal characteristics.....	50
5	I/O Parameters.....	20	15.1	General notes for specifications at maximum junction temperature.....	51
5.1	I/O pad DC electrical characteristics	20	15.2	References.....	53
5.2	I/O pad AC specifications.....	21	16	Packaging.....	53
5.3	Aurora LVDS driver electrical characteristics.....	22	17	Reset sequence.....	54
5.4	Reset pad electrical characteristics.....	22	17.1	Reset sequence duration.....	54
6	Peripheral operating requirements and behaviors.....	24	17.2	Reset sequence description.....	54
6.1	Clocks and PLL Specifications.....	24	18	Power sequencing requirements.....	57
7	Analog.....	27	19	Package pinouts and signal descriptions.....	58
7.1	ADC electrical characteristics.....	27	20	Release Notes.....	59
8	Memory modules.....	29			
8.1	Flash memory program and erase specifications.....	29			
8.2	Flash memory Array Integrity and Margin Read specifications.....	30			

1 Introduction

1.1 Chip comparison

The following table provides a comparison and their proposed features of three devices S32R372, S32R274 and MPC5775K . For full details of all of the family derivatives please contact your marketing representative.

Table 1. S32R372 Chip comparison table

Feature	S32R372	S32R274	MPC5775K
CPU	2x e200z7260	2x e200z7260 e200z420 lock-step	
SIMD	SPE2 + EFP2 (both z7)	SPE2 + EFP2 (both z7)	SPE2 + EFP2 (both z7)
Maximum Operating Frequency	240 MHz	240 MHz (z7) 180 MHz (z4)	266 MHz (z7) 133 MHz (z4)
Flash	1.3 MB with ECC	2 MB with ECC	4 MB with ECC
EEPROM support	32K (emulation)	64K (emulation)	96K (emulation)
RAM	1 MB with ECC	1.5 MB with ECC	1.5 MB with ECC
ECC	end-to-end		
MPU	CoreMPU: 24 entries per core SystemMPU: 2x16 entries		
eDMA	safe eDMA with 32 channels, 64 triggers		
Control ADC ¹	2x 12-bit SAR ADC, 1 MSps input mux for 16 external channels	2x 12-bit SAR ADC, 1 MSps input mux for 16 external channels	4x 12bit SAR ADC, 1 MSps, input mux for 37 external channels
RADAR ADC	-	4x 12-bit $\Sigma\Delta$ ADC, 10 MSps	8x 12-bit $\Sigma\Delta$ ADC, 10 MSps
SPT	1x v2.5	1x v2	1x v1
CTE ¹	1x		
WGM	-	1x	1x
CTU	1x	1x	2x
SWT	2x	3x	3x
STM	2x	3x	3x
PIT	2x		
CRC	2x		
SEMA42	1x		
LINFlexD ²	1x	1x	4x
FlexCAN	2x FlexCAN-FD	3x FlexCAN including 2x FlexCAN-FD	4x FlexCAN + 1x MCAN-FD
SPI ¹	2x	2x	4x

Table continues on the next page...

Table 1. S32R372 Chip comparison table (continued)

Feature	S32R372	S32R274	MPC5775K
I ² C ³	2x	2x	3x
Zipwire	-	1x LFAST+SIPI, 320MHz	
FlexRay	-	1x dual channel	
Ethernet	-	10/100 and >100 Mbps, RMII/MII/ RGMII I/F, AVB support	10/100Mbps, RMII/MII I/F, AVB support
FlexPWM ¹	1x, 12 PWM channels	1x, 12 PWM channels	2x, 12 PWM channels each
eTimer ¹	1x, 6 channels	2x, 6 channels each	3x, 6channels each
External ADC interface	1x 2 lanes MIPICSI2 Rx, 1Gbps/lane	1x 4 lanes MIPICSI2 Rx, 1Gbps/lane	1x PDI (16-bit data, clock, sync)
IRCOSC	16 MHz		
XOSC	40 MHz		
FMPLL	dual system PLL, 1x FM modulated		
DAC	-	1x 12-bit 10MSps	1x 12-bit 2MSps
SIUL2 ¹	1x		
BAM	1x		
INTC	1x		
SSCM	1x		
FCCU/FOSU	1x		
MEMU	1x		
STCU2	1x		
CSE	1x	1x	-
PASS	1x	1x	-
TDM	1x	1x	-
MC_ME	1x		
MC_CGM	1x		
MC_RGM	1x		
TSENS	2x		
Debug	JTAGC, JTAGM, CJTAG, with class3+Nexus, Aurora only		
Safety Level	ISO26262 SEooC ASIL-B	ISO26262 SEooC ASIL-B to ASIL-D	
Temp. Range (Tj)	-40 to +150°C		

1. This chip offers limited functionality with 10 mm x 10 mm outline. For details see [Feature list](#)

2. Available only with 14 mm x 14 mm outline for this chip.

3. Single I²C available with 10 mm x 10 mm outline for this chip.

1.2 Feature list

On-chip modules available within the device include the following features:

- Two computation cores: Power Architecture e200z7 32-bit CPU

- Dual issue: up to two instructions per clock cycle
- Harvard architecture with 64-bit bus for data instructions
- 16 KB instruction cache and 16 KB data cache
- 64 KB data local memory
 - with background load/store: backdoor access
 - 0-wait state for all read and 32/64-bit write accesses
 - Low number of wait states for backdoor accesses
- Support for decorated storage
- Using variable length encoding (VLE) for higher code density
- 4-way integer processing unit (SPE2)
- 2-way single-precision Floating Point Unit (EFP2)
- 1.3 MB on-chip code flash (FMC flash) with ECC
 - Three ports (one per CPU, one for RADAR processing) shared between code and data flash with 4×256 bit buffer for code and data flash including prefetch functions
 - Data flash is part of the code flash module
 - Including 32 KB EEPROM emulation
- 1 MB on-chip SRAM with ECC
 - Decorated memory controller to support atomic read-modify-write operations
 - Single- and double-bit error visibility is supported
 - Four ports (one per CPU, one for RADAR processing, one for all other) and up to 6 banks allow simultaneous accesses from different masters to different banks
- RADAR processing
 - Signal Processing Toolbox (SPT) for RADAR signal processing acceleration
 - Cross Triggering Engine (CTE) for precise timing generation and triggering¹
 - MIPICSI2 interface to connect external ADCs
 - Two data lanes, with up to 1 GB/s per lane and in total
 - One clock lane
- Memory protection
 - Each core memory protection unit provides 24 entries
 - Data and instruction bus system memory protection Unit (SMPU) with 16 region descriptors each
 - Register protection
- Clock generation
 - 40 MHz external crystal (XOSC)
 - 16 MHz Internal oscillator (IRCOSC)
 - Dual system PLL with one frequency modulated phase-locked loop (FMPLL)
 - Low-jitter SDPLL
- Functional safety

1. This chip offers limited functionality with 10 mm x 10 mm outline.

- Typical use: ASIL B applications
- End-to-end ECC ensuring full protection of all data access throughout the system, from each system masters through the crossbar and to the memories and peripherals
- FCCU for fault collection and fault handling
- MEMU for memory error management
- safe eDMA controller
- User selectable Memory BIST (MBIST) can be enabled to run out of various reset conditions or during runtime
- Self-Test Control Unit (STCU2)
- Error Injection Module (EIM)
- On-chip voltage monitoring
- Clock Monitor Unit (CMU) to support monitoring of critical clocks
- Security
 - Hardware Security Module (CSE2) enabling advanced security management
 - Supports censorship and life-cycle management via Password and Device Security (PASS) module
 - Diary control for tamper detection (TDM)
- Support Modules
 - Global Interrupt controller (INTC) capable of routing interrupts to any CPU
 - Semaphore unit to manage access to shared resources
 - Two CRC computation units with four polynomials
 - 32-channels eDMA controller with multiple transfer request sources using DMAMUX
 - Boot Assist Module (BAM) supports internal flash programming via a serial link (LIN / CAN)
- Timers
 - Two Periodic Interval Timers (PIT) with 32-bit counter resolution
 - Two System Timer Module (STM)
 - Two Software Watchdog Timers (SWT)
 - One eTimer modules with 6 channels²
 - One FlexPWM module for 12 PWM signals¹
- Communication interfaces
 - Two Serial Peripheral interface (SPI) module³
 - Two inter-IC communication interface (I2C) modules⁴
 - One LINFlexD module⁵
 - Two FlexCAN modules supporting CAN FD with configurable buffers
- Debug functionality

2. Less channel in 10 mm x 10 mm outline.

3. One SPI offers less number of chip-selects in 10 mm x 10 mm outline.

4. Single I²C in 10 mm x 10 mm outline.

5. Available only with 14 mm x 14 mm outline for this chip.

- 4-pin JTAG interface and Nexus/Aurora interface for serial high-speed tracing
- e200Z7 cores: Nexus development interface (NDI) per IEEE-ISTO 5001-2012 Class 3+
- All platform bus masters can be monitored via Nexus/Aurora
- Device/board boundary Scan testing supported with per Joint Test Action Group (JTAG) (IEEE 1149.1) and 1149.7 (cJTAG)
- On-chip control for Nexus development interface by JTAGM module
- Two analog-to-digital converters (SAR ADC)
 - Each ADC supports up to 16 input channels²
 - Cross Trigger Unit to enable synchronization of ADC conversions with eTimer
- On-chip voltage DC/DC regulator for core supply generation (VREG)⁵
- Two Temperature Sensors (TSENS)

1.3 Block diagram

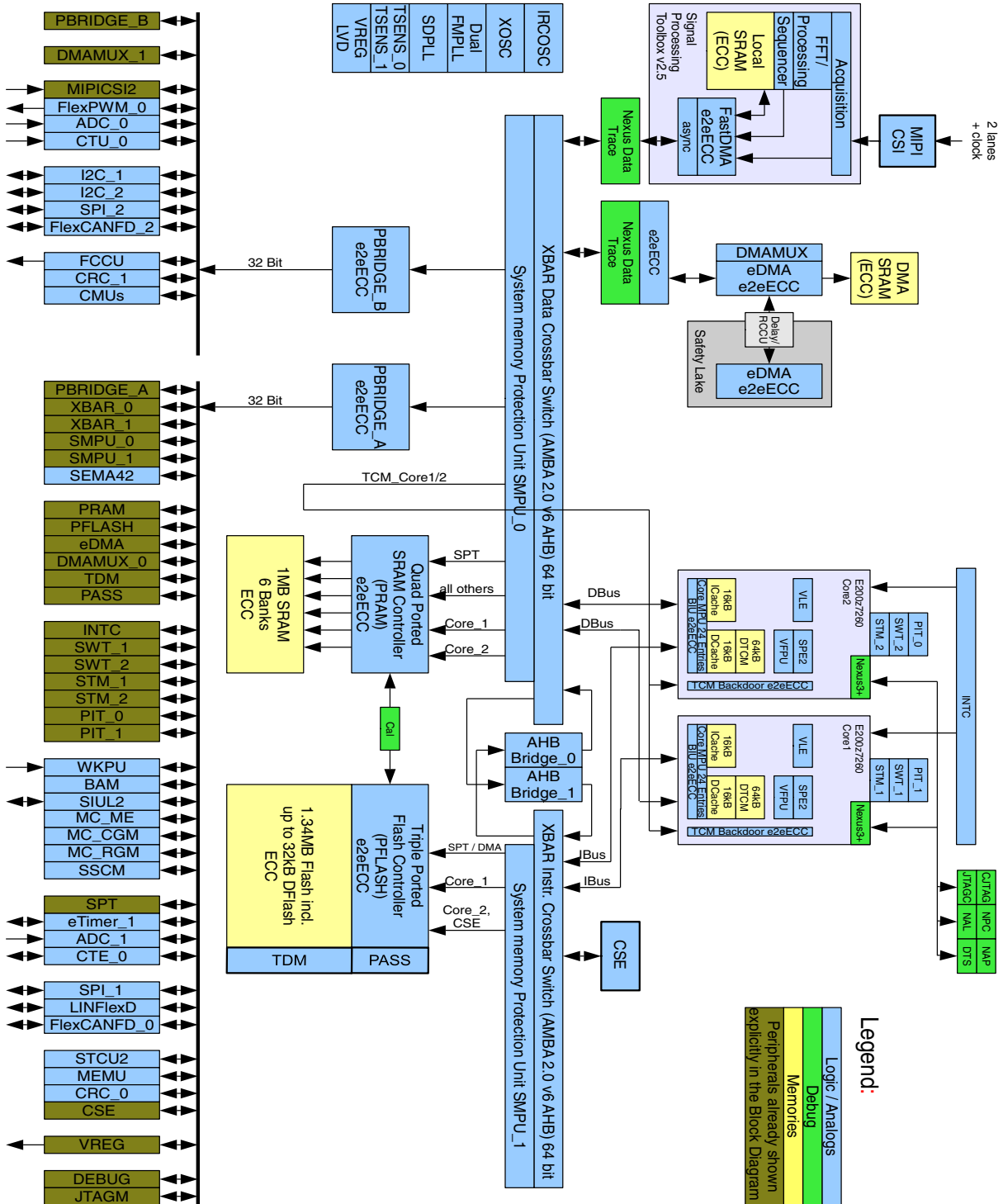

Figure 1. Architecture Block Diagram

2 Ordering parts

2.1 Determining valid orderable parts

Valid orderable part numbers are provided on the web. To determine the orderable part numbers for this device, go to www.nxp.com and perform a part number search for the device number.

3 Part identification

3.1 Description

Part numbers for the chip have fields that identify the specific part. You can use the values of these fields to determine the specific part you have received.

3.2 Format

Part numbers for this device have the following format: S32R372.

3.3 Fields

This section lists the possible values for each field in the part number (not all combinations are valid):

Part identification

F/P	—Product Status - P for prototype and F for qualified ordering part number
S32	—Product Type/Brand – 32-bit Auto MCU
R	—Product Line - Radar (R)
3	—Generation 3rd generation
7	—Core - z7 Power Architecture
2	—Product, number of cores
K	—Performance
A	—Configuration
K0	—Fab and Mask Revision – K (TSMC14), 0 (MASK)
M	—Temperature Suffix - M (-40 °C to 125°C Ta), V (-40 °C to 105 °C Ta)
MM	—Package Suffix - 257 MAPBGA (MM) 141 MAPBGA (MV)
R	—Tape and Reel Indicator - R (Tape and Reel)

Figure 2. Commercial product code structure

Table 2. ASCII code for performance

Perf (MHz)	Z7	Z7
S	240	240

Table 3. ASCII code for 257 MAPBGA configuration

257MAPBGA	Configuration	1.3 MB Flash	768 KB RAM	1 MB RAM	CSE
PS32R372SAK0M MM	A	Yes	No	Yes	Yes
FS32R372SBK0M MM	B	Yes	Yes	No	Yes
FS32R372SCK0M MM	C	Yes	Yes	No	No
FS32R372SDK0M MM	D	Yes	No	Yes	Yes
FS32R372SEK0M MM	E	Yes	No	Yes	No

Table 4. ASCII code for 141MAPBGA configuration

141MAPBGA	Configuration	1.3 MB Flash	768 KB RAM	1 MB RAM	CSE
PS32R372SAK0M MV	A	Yes	No	Yes	Yes
FS32R372SBK0M MV	B	Yes	Yes	No	Yes
FS32R372SCK0M MV	C	Yes	Yes	No	No
FS32R372SDK0M MV	D	Yes	No	Yes	Yes
FS32R372SEK0M MV	E	Yes	No	Yes	No

4 General

4.1 Introduction

The electrical specifications are preliminary and are undergoing initial evaluation. These specifications may not be fully tested or guaranteed at this early stage of the product life cycle. Finalized specifications will be published after complete characterization and device qualifications have been completed.

4.2 Absolute maximum ratings

NOTE

Functional operating conditions appear in the DC electrical characteristics. Absolute maximum ratings are stress ratings only, and functional operation at the maximum values is not guaranteed.

Stress beyond the listed maximum values may affect device reliability or cause permanent damage to the device.

Table 5. Absolute maximum ratings

Symbol	Parameter	Conditions	Min	Max	Unit
V _{DD_HV_PMU}	3.3 V PMU supply voltage	—	-0.3	3.63 ^{1, 2}	V
V _{DD_HV_REG3V8}	SMPS driver input Supply Voltage	—	-0.3	5.5	V

Table continues on the next page...

Table 5. Absolute maximum ratings (continued)

Symbol	Parameter	Conditions	Min	Max	Unit
$V_{DD_HV_IO^*}$	3.3 V Input/Output Supply Voltage, and PWM IO Supply	—	-0.3	3.63 ^{1, 2}	V
$V_{SS_HV_IOx}$	Input/output ground voltage	—	-0.1	0.1	V
$V_{DD_HV_FLA}$	3.3 V flash supply voltage	—	-0.3	3.63 ^{1, 2}	V
$V_{DD_HV_RAW}$	AFE RAW supply voltage	—	-0.1	4	V
$V_{DD_HV_DAC}$	AFE DAC supply voltage	—	-0.1	4	V
$V_{DD_LV_IO^*}$	Aurora supply voltage ^{3, 4, 5}	—	-0.3	1.5	V
V_{DD}	1.25 V core supply voltage ^{3, 4, 5}	—	-0.3	1.5	V
V_{SS}	1.25 V core supply ground	—	-0.3	0.3	V
$V_{SS_LV_OSC}$	Oscillator amplifier ground	—	-0.1	0.1	V
$V_{DD_LV_PLL0}$	System PLL supply voltage ^{3, 4, 5}	—	-0.3	1.5	V
$V_{DD_HV_ADCREFO/1}$	ADC_0 and ADC_1 high reference voltage	—	-0.3	5.5	V
$V_{SS_HV_ADCREFO/1}$	ADC_0 and ADC_1 ground and low reference voltage	—	-0.1	0.1	V
$V_{DD_HV_ADC}$	3.3 V ADC supply voltage	—	-0.3	4.0 ^{1, 2}	V
$V_{SS_HV_ADC}$	3.3 V ADC supply ground	—	-0.1	0.1	V
TV_{DD}	Supply ramp rate ⁶	—	0.00005	0.1	V/ μ s
V_{IN_XOSC}	Voltage on XOSC pins with respect to ground	—	-0.3	1.47	V
V_{INA}	Voltage on SAR ADC analog pin with respect to ground ($V_{SS_HV_ADCREFX}$)	—	-0.3	6.0	V
V_{IN}	Voltage on any digital pin with respect to ground ($V_{SS_HV_IOx}$)	Relative to $V_{DD_HV_IOx}$	-0.3	$V_{DD_HV_IOx} + 0.3$ ⁷	V
$V_{DD_LV_DPHY}$	MIPICSI2 DPHY voltage supply ^{3, 4, 5}	—	-0.3	1.5	V
$V_{SS_LV_DPHY}$	MIPICSI2 DPHY supply ground	—	-0.3	0.3	V
I_{INJPAD}	Injected input current on any pin during overload condition ⁸	—	-5	+5	mA
I_{INJSUM}	Absolute sum of all injected input currents during overload condition	—	-50	50	mA
T_{STG}	Storage temperature	—	-55	150	$^{\circ}$ C

- 5.3 V for 10 hours cumulative over lifetime of device; 3.3 V +10% for time remaining.
- Voltage overshoots during a high-to-low or low-to-high transition must not exceed 10 seconds per instance.
- 1.45 V to 1.5 V allowed for 60 seconds cumulative time at maximum $T_J = 150^{\circ}$ C; remaining time as defined in note 5 and note 6.
- 1.375 V to 1.45 V allowed for 10 hours cumulative time at maximum $T_J = 150^{\circ}$ C; remaining time as defined in note 6.
- 1.32 V to 1.375 V range allowed periodically for supply with sinusoidal shape and average supply value below 1.275 V at maximum $T_J=150^{\circ}$ C.
- TV_{DD} is relevant for all external supplies.
- Only when $V_{DD_HV_IOx} < 3.63$ V.
- No input current injection circuitry on AFE pins.

4.3 Operating conditions

The following table describes the operating conditions for the device, and for which all specifications in the datasheet are valid, except where explicitly noted. The device operating conditions must not be exceeded, or the functionality of the device is not guaranteed.

Table 6. Device operating conditions

Symbol	Parameter	Conditions	Min	Typ	Max ¹	Unit
V _{DD_HV_PMU}	3.3V PMU Supply Voltage	—	3.13 ²	3.3	3.6	V
V _{DD_HV_REG3V8}	SMPS driver input Supply Voltage	—	3.13	3.8	5.5	V
V _{DD}	Core Supply Voltage	—	1.19 ²	1.25	1.31 ³	V
V _{DD_HV_IO*}	Main GPIO 3V Supply Voltage, and PWM IO Supply Voltage	—	3.13 ²	3.3	3.6	V
V _{DD_LV_IO*}	Aurora Supply Voltage	—	1.19	1.25	1.31	V
V _{DD_LV_PLL0}	System PLL Supply Voltage	—	1.19 ²	—	1.31	V
V _{DD_HV_FLA} ⁴	Flash Supply Voltage	—	3.13 ²	3.3	3.6	V
V _{DD_HV_ADC}	SAR ADC Supply Voltage (HVD supervised)	—	3.13 ²	3.3	3.6 ⁵	V
V _{DD_HV_RAW} ⁶	3.3V AFE RAW Supply Voltage	—	3.13	3.3	3.6	V
V _{DD_HV_DAC}	3.3V AFE DAC Supply Voltage	—	3.13	3.3	3.6	V
V _{DD_HV_ADCREF0/1}	ADC_0 and ADC_1 high reference voltage	—	3.13	3.3	3.6	V
V _{IN}	Voltage on digital pin with respect to ground (V _{SS_HV_IOx})	—	—	—	V _{DD_HV_IOx} + 0.3	V
V _{INA} ⁷	Voltage on SAR ADC analog pin with respect to ground (V _{SS_HV_ADCREFx})	—	—	—	V _{DD_HV_ADCREFx}	V
V _{DD_LV_DPHY}	MIPICSI2 DPHY voltage supply	—	1.19	1.25	1.31	V
T _A ⁸	Ambient temperature at full performance ⁹	—	-40	—	125	°C
T _J ⁸	Junction temperature	—	-40	—	150	°C
F _{XTAL}	XOSC Crystal Frequency ¹⁰	—	—	40	—	MHz
AFE Bypass Modes Only						
Single-Ended External Clock						
EXTAL _{clk}	EXTAL external clock frequency			40		MHz
V _{inxoscjit}	EXTAL external clock Cycle to Cycle Jitter (RMS)	—	—	—	3.5	ps
V _{inxoscclkvil}	EXTAL external clock input low voltage	—	0	—	0.4	V
V _{inxoscclkvih}	EXTAL external clock input high voltage	—	1	—	1.23	V
t _r /t _f	Rise/fall time of EXTAL external clock input				1	ns
t _{dc}	Duty Cycle of EXTAL external clock input		47	50	53	%

Table continues on the next page...

Table 6. Device operating conditions (continued)

Symbol	Parameter	Conditions	Min	Typ	Max ¹	Unit
Differential LVDS External Clock						
LVDS _{clk}	LVDS external clock frequency			40		MHz
LVDSV _{inxsocclk}	LVDS external clock input voltage		0		1.36	V
LVDSV _{inxsocclk(p-p)}	LVDS external clock input voltage (peak-peak)	Voltage driven, AC coupled Differential	0.45	0.70	1.12	V
LVDSI _{inxsocclk}	LVDS external clock input current	Current driven, DC coupled.	3.0	3.5	4.0	mA
LVDSV _{inxsocjit}	LVDS external clock Jitter (RMS)				3.5	ps
t _r /t _f	Rise/fall time of LVDS external clock input	20% - 80%			1.5	nS
t _{dcLVDS}	Duty Cycle of LVDS external clock input		47	50	53	%

1. Full functionality cannot be guaranteed when voltages are out of the recommended operating conditions.
2. Min voltage takes into account the LVD variation.
3. Max voltage takes into account HVD variation.
4. The ground connection for the V_{DD_HV_FL A} is shared with V_{SS}.
5. Supply range does not take into account HVD levels. Full range can be achieved after power-up, if HVD is disabled. See [Voltage regulator electrical characteristics](#) section for details.
6. For 141MAPBGA package, V_{DD_HV_RAW} and V_{DD_HV_DAC} supplies share the same pin in the package.
7. On channels shared between ADC0 and 1, V_{DD_HV_AD CREFx} is the lower of V_{DD_HV_AD CREF0/1}.
8. When determining if the operating temperature specifications are met, either the ambient temperature or junction temperature specification can be used. It is critical that the junction temperature specification is not exceeded under any condition
9. Full performance means Core1/2 running @ 240 MHz, SPT running @ 160 MHz, rich set of peripherals used.
10. Recommended Crystal 40 MHz (ESR≤30 Ω), 8 pF load capacitance.

4.4 Supply current characteristics

Current consumption data is given in the following table. These specifications are design targets and are subject to change per device characterization.

Table 7. Current consumption characteristics

Symbol	Parameter	Conditions	Min	Typ	Max	Unit
I _{DD_CORE}	Core current in run mode	All cores at max frequency. 1.31 V. T _j = 150°C	-	-	1100 ¹	mA
I _{DD_HV_FL A}	Flash operating current	T _j = 150°C. V _{DD_HV_FL A} = 3.6 V	-	3 ²	40 ³	mA
I _{DD_LV_AURORA}	Aurora operating current	T _j = 150°C. V _{DD_LV_AURORA} = 1.31 V. 4 TX lanes enabled.	-	-	60	mA
I _{DD_HV_AD C}	ADC operating current	T _j = 150°C. V _{DD_HV_AD C} = 3.6 V. 2 ADCs operating at 80 MHz.	-	2	5	mA
I _{DD_HV_AD CREF}	Reference current per ADC ⁴	T _j = 150°C. V _{DD_HV_AD CREFx} = 3.6 V. ADC operating at 80 MHz.	-	-	1.5 0.75	mA

Table continues on the next page...

Table 7. Current consumption characteristics (continued)

Symbol	Parameter	Conditions	Min	Typ	Max	Unit
	Reference current per temp sensor ⁵					
I _{DD_HV_RAW}	AFE and regulator operating current	T _J = 150°C. V _{DD_HV_RAW} = 3.6 V. SD-PLL and AFE regulators enabled.	-	13.4 ⁶	16	mA
I _{DD_HV_DAC}	AFE DAC operating current	T _J = 150°C. V _{DD_HV_DAC} = 3.6 V. SD-PLL and DAC enabled.	-	1.5	2	mA
I _{DD_HV_PMU}	PMU operating current	T _J = 150°C. V _{DD_HV_PMU} = 3.6 V. Internal regulation enabled.	-	2	10	mA
I _{DD_LV_DPHY}	MIPICS12 DPHY operating current in HS-RX mode	T _J = 150°C, V _{DD_LV_DPHY} = 1.31 V	8.7	14.9	23.2	mA

1. Strong dependence on use case, cache usage.
2. Measured during flash read.
3. Peak Flash current measured during read while write (RWW).
4. ADC0 and 1 on ADCREF0/1.
5. Temp sensor current when PMC_CTL_TD[TSx_AOUT_EN] = 1. TS0 on ADCREF0/1.
6. Typical number is approximately 12 mA for SD-PLL and 1 mA for the AFE regulators.

4.5 Voltage regulator electrical characteristics

Table 8. Voltage regulator electrical specifications

Symbol	Parameter	Conditions	Min	Typ	Max	Unit
POR-R	1.25 V VDD core POR release	—	0.97	1.02	1.06	V
POR-E	1.25 V VDD core POR engage	—	0.93	0.98	1.02	V
LVD12R	Low-Voltage Detection 1.25 V release (Core VDD supply, and PLL0/1 supply LVDs)	Untrimmed	1.122	1.157	1.192	V
LVD12R-trim		Trimmed	1.142	1.157	1.172	V
LVD12E	Low-Voltage Detection 1.25 V engage (Core VDD supply and PLL0/1 supply LVDs)	Untrimmed	1.102	1.137	1.172	V
LVD12E-trim		Trimmed	1.122	1.137	1.152	V
HVD12R-trim	High-Voltage Detection 1.25 V release (Core VDD)	Trimmed	1.33	1.35	1.37	V
HVD12E-trim	High-Voltage Detection 1.25 V engage (Core VDD supply)	Trimmed	1.36	1.38	1.40	V
LVD_MIP112R-trim	Low-Voltage Detection 1.25V release (MIPICS12 DPHY supply)	—	1.130	1.157	1.184	V
LVD_MIP112E-trim	Low-Voltage Detection 1.25V engage (MIPICS12 DPHY supply)	—	1.111	1.137	1.163	V
POR-R-VDD_HV_PMU	3.3 V PMU supply voltage POR release threshold	—	2.54	2.645	2.735	V
POR-E-VDD_HV_PMU	3.3 V PMU supply voltage POR engage threshold	—	2.50	2.60	2.695	V
LVD33R	3.3V Low-Voltage Detection Release Threshold (PMC, FLASH, IO, ADC)	Untrimmed	2.90	3.02	3.13	V
LVD33R-trim		Trimmed	3.00	3.05	3.10	V

Table continues on the next page...

Table 8. Voltage regulator electrical specifications (continued)

Symbol	Parameter	Conditions	Min	Typ	Max	Unit
LVD33E	3.3V Low-Voltage Detection Engage Threshold (PMC, FLASH, IO, ADC)	Untrimmed	2.86	2.98	3.09	V
LVD33E-trim		Trimmed	2.96	3.01	3.06	V
HVD33R	3.3V High-Voltage Detection Release Threshold (ADC)	Untrimmed	3.45	3.61	3.75	V
HVD33R-trim		Trimmed	3.47	3.53	3.58	V
HVD33E	3.3V High-Voltage Detection Engage Threshold (ADC)	Untrimmed	3.51	3.65	3.79	V
HVD33E-trim		Trimmed	3.51	3.57	3.62	V
UVL30R	SMPS under-voltage lockout release threshold	Untrimmed	2.75	2.90	3.05	V
UVL25E	SMPS under-voltage lockout engage threshold		2.40	2.55	2.7	V
DGLITCHE	Voltage Detector Deglitcher Filter Time - Engage	—	2.0	3.5	5	µs
DGLITCHR	Voltage Detector Deglitcher Filter Time - Release	—	5	7	12	µs
RSTDGLTC	VREG_POR_B Input Deglitch Filter Time	—	200	320	500	ns
RSTPUP	VREG_POR_B Pin Pull-up Resistance	—	37	75	150	kΩ
REGENPUP	VREG_SEL Pin Pull-up Resistance	—	37	75	150	kΩ
VSMPS	Internal switched regulator output voltage ¹	Load Current from 10 mA to 1.8 A	1.19	1.255	1.35	V
FSMPS	Internal switched regulator operating frequency without modulation	Untrimmed	0.65	1.00	1.35	MHz
		Trimmed	0.93	1.00	1.07	MHz
FSMPS-M7.5	Internal switched regulator frequency modulation	—	—	7.5	—	%
FSMPS-M15		—	—	15	—	%
FSMPS-M30		—	—	30	—	%
VREGSWPUP	Internal switched regulator gate-driver pull-up resistance ²	—	—	—	—	—
VREF_BG_T	PMC bandgap reference voltage for SARADC	Trimmed	1.20	1.22	1.237	V
Vih (VREG_POR_B)	VREG_POR_B pin High Voltage level	—	0.7 x VDD_H V_PMU	—	VDD_H V_PMU + 0.3	V
Vil (VREG_POR_B)	VREG_POR_B pin Low Voltage level	—	-0.3	—	0.3 x VDD_H V_PMU	V
LVDAFER	Low Voltage Detection 3.3V Release (AFE VDD_HV_DAC and VDD_HV_RAW supplies)	—	2.75	2.80	2.90	V
LVDAFEE	Low Voltage Detection 3.3V Engage (AFE VDD_HV_DAC and VDD_HV_RAW supplies)	—	2.68	2.77	2.86	V

1. Min/Max includes transient load conditions. Steady state voltage is within the core supply operating specifications.

2. There is a strong pull up from VREG_SWP to VDD_HV_REG3V8 which is connected when SMPS is disabled. The pullup has resistance less than 1 Kohm, therefore VREG_SWP should not be connected to ground if unused.

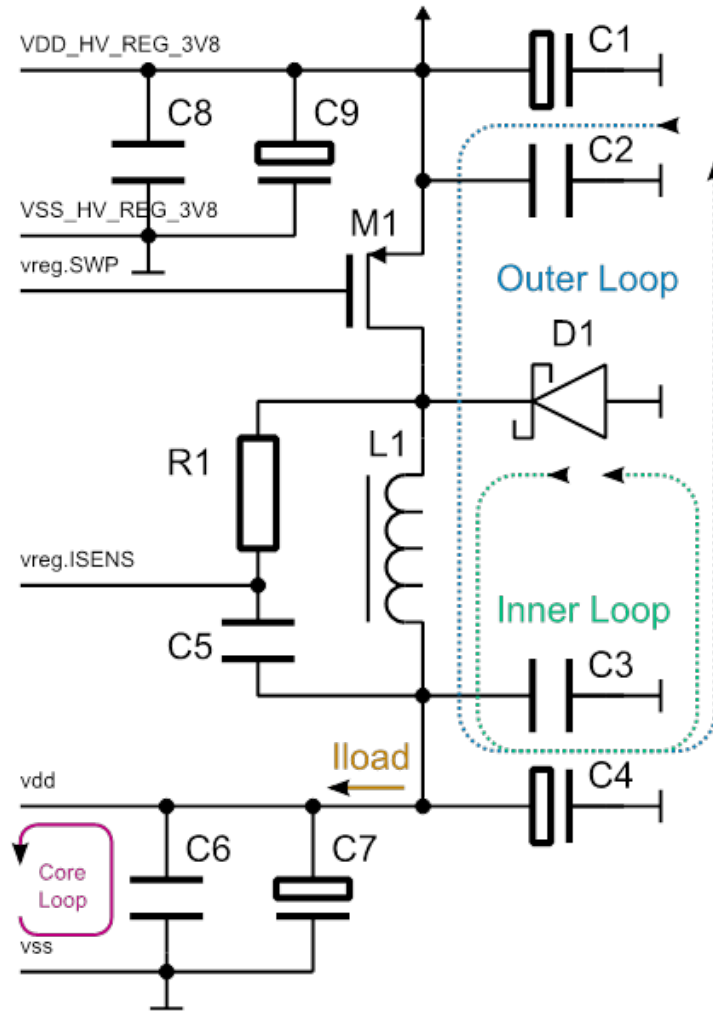

Figure 3. SMPS External Components Configuration

Table 9. SMPS External Components

Ref	Description
M1	SI3443, 2SQ2315
L1	2.2 uH 3A < 100 mΩ series resistance (Ex. Bourns SRU8043-2R2Y)
D1	SS8P3L 8A Schottcky Diode
R1	24 kΩ
C1	10 μF Ceramic
C2	100 nF Ceramic
C3	100 nF Ceramic (place close to inductor)
C4	10 uF Ceramic (place close to inductor)
C5	1 nF Ceramic
C6	4 x 100 nF + 4 x 10nF Ceramic (place close to MCU supply pins)
C7	4 x 10 μF Ceramic (place close to MCU supply pins)
C8	100 nF Ceramic
C9	1 μF Ceramic (Unless C1 is really close to the pin)

NOTE

Internal DC-DC (SMPS) regulation mode is only supported in BGA257, for BGA141 an external 1.25 V (nominal) supply is required for device operation.

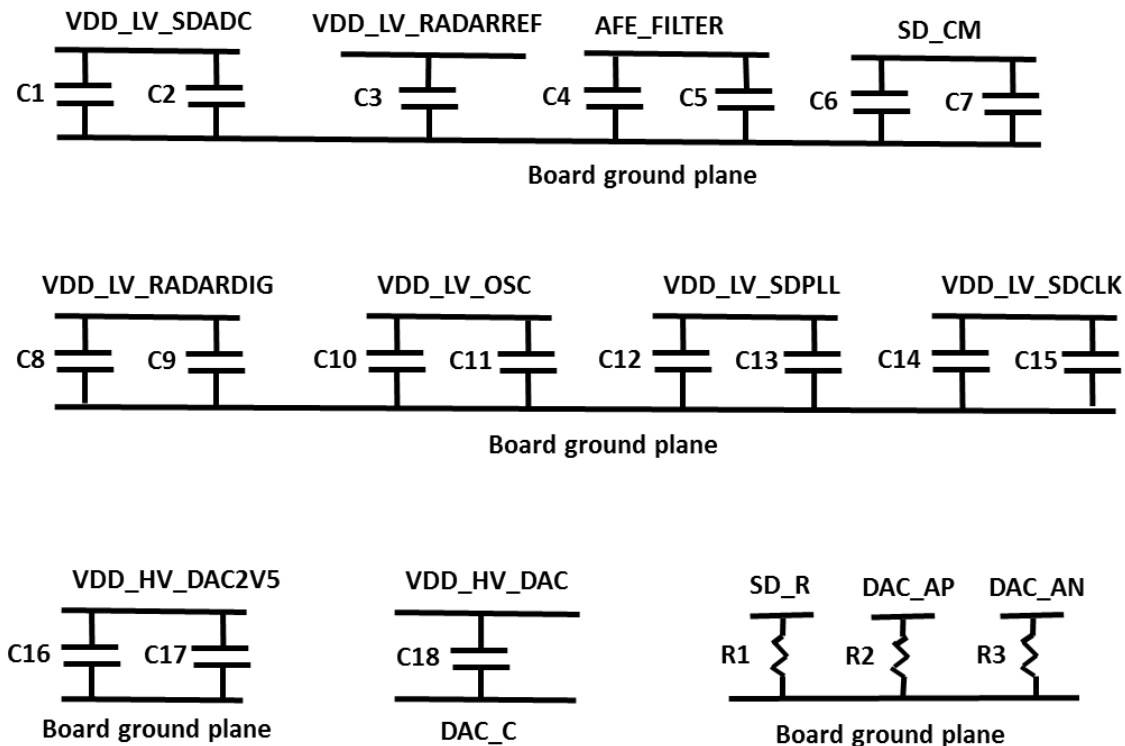

Figure 4. Radar AFE External Components Configuration

Table 10. Radar AFE External Components

Component	Component Value	Tolerance	Placement Priority of larger cap. ¹	Placement Priority of smaller cap ¹	Special notes
C1	0.47 μ F	\pm 35%	3	—	—
C2	0.1 μ F	\pm 35%	—	1	—
C3	1.0 μ F	\pm 35%	7	—	—
C4	1.0 μ F	\pm 35%	2	—	—
C5	0.1 μ F	\pm 35%	—	4	—
C6	1.0 μ F	\pm 35%	8	—	—
C7	0.1 μ F	\pm 35%	—	6	—
C8	1.0 μ F	\pm 35%	6	—	—
C9	0.1 μ F	\pm 35%	—	5	—
C10	1.0 μ F	\pm 35%	4	—	—
C11	0.1 μ F	\pm 35%	—	2	—
C12	1.0 μ F	\pm 35%	5	—	—

Table continues on the next page...

Table 10. Radar AFE External Components (continued)

Component	Component Value	Tolerance	Placement Priority of larger cap. ¹	Placement Priority of smaller cap. ¹	Special notes
C13	0.1 μ F	$\pm 35\%$	—	3	—
C14	1.0 μ F	$\pm 35\%$	10	—	—
C15	0.1 μ F	$\pm 35\%$	—	8	—
C16	1.0 μ F	$\pm 35\%$	9	—	—
C17	0.1 μ F	$\pm 35\%$	—	7	—
C18	10 μ F	—	1	—	X7R type
R1	40.2 k Ω	$\pm 0.1\%$	—	—	tempco = 25ppm/C
R2	300 Ω	—	—	—	DAC RI See Table 1
R3	300 Ω	—	—	—	DAC RI See Table 1
Crystal	40MHz	—	—	—	Connected between XOSC_EXTAL/ XOSC_XTAL, ESR $\leq 30\Omega$

1. All Radar AFE external bypass capacitors should be placed as close as possible to the associated package pin. As shown in [Radar AFE External Components Configuration](#) figure, most pins have two values of bypass capacitor. Greater than 0.1 μ F is referred to as the larger cap. 0.1 μ F is referred to as the smaller cap

4.6 Electromagnetic Compatibility (EMC) specifications

EMC measurements to IC-level IEC standards are available from NXP on request.

4.7 Electrostatic discharge (ESD) characteristics

Electrostatic discharges (a positive then a negative pulse separated by 1 second) are applied to the pins of each sample according to each pin combination. The sample size depends on the number of supply pins in the device (3 parts \times ($n + 1$) supply pin). This test conforms to the AEC-Q100-002/-003/-011 standard.

NOTE

A device will be defined as a failure if after exposure to ESD pulses the device no longer meets the device specification requirements. Complete DC parametric and functional testing shall be performed per applicable device specification at room

temperature followed by hot temperature, unless specified otherwise in the device specification.

Table 11. ESD ratings

No.	Symbol	Parameter	Conditions ¹	Class	Max value ²	Unit
1	$V_{ESD(HBM)}$	Electrostatic discharge (Human Body Model)	$T_A = 25\text{ °C}$ conforming to AEC-Q100-002	H1C	2000	V
2	$V_{ESD(CDM)}$	Electrostatic discharge (Charged Device Model)	$T_A = 25\text{ °C}$ conforming to AEC-Q100-011	C3A	500 ^{3, 4, 5} 750 (corners)	V

1. All ESD testing is in conformity with CDF-AEC-Q100 Stress Test Qualification for Automotive Grade Integrated Circuits.
2. Data based on characterization results, not tested in production.
3. 500 V for non-AFE pins, 250 V for AFE pins.
4. AFE pins for 257MAPBGA: balls C3-C4, D1-D2, D6, D8, E1-E2, F1-F4, G3-G4, H3-H4.
5. AFE pins for 141MAPBGA: balls A1, B1, C1-C3, D1-D3, E1.

5 I/O Parameters

5.1 I/O pad DC electrical characteristics

NMI, TCK, TMS, JCOMP are treated as GPIO.

Table 12. I/O pad DC electrical specifications

Symbol	Parameter	Value		Unit
		Min	Max	
Vih_hys	CMOS Input Buffer High Voltage (with hysteresis enabled)	$0.65 * V_{DD_HV_IO}$	$V_{DD_HV_IO} + 0.3$	V
Vil_hys	CMOS Input Buffer Low Voltage (with hysteresis enabled)	-0.3	$0.35 * V_{DD_HV_IO}$	V
Vih	CMOS Input Buffer High Voltage (with hysteresis disabled)	$0.55 * V_{DD_HV_IO}$	$V_{DD_HV_IO} + 0.3$	V
Vil	CMOS Input Buffer Low Voltage (with hysteresis disabled)	-0.3	$0.40 * V_{DD_HV_IO}$	V
Vhys	CMOS Input Buffer Hysteresis	$0.1 * V_{DD_HV_IO}$	—	V
Vih_TTL	TTL Input high level voltage (All SAR_ADC input pins)	2	$V_{DD_HV_ADCREFx} + 0.3$	V
Vil_TTL	TTL Input low level voltage (All SAR_ADC input pins)	-0.3	0.56	V
Vhyst_TTL	TTL Input hysteresis voltage (All SAR_ADC input pins)	0.3	—	V
Pull_Ioh	Weak Pullup Current ¹	10	55	μA
Pull_Iol	Weak Pulldown Current ²	10	55	μA
Iinact_d	Digital Pad Input Leakage Current (weak pull inactive)	-2.5	2.5	μA

Table continues on the next page...

Table 12. I/O pad DC electrical specifications (continued)

Symbol	Parameter	Value		Unit
		Min	Max	
Voh	Output High Voltage ³	0.8 * V _{DD_HV_IO}	—	V
Vol	Output Low Voltage ⁴	—	0.2 * V _{DD_HV_IO}	V
Ioh_f	Full drive Ioh ⁵ (ipp_sre[1:0] = 11)	18	70	mA
Iol_f	Full drive Iol ⁵ (ipp_sre[1:0] = 11)	21	120	mA
Ioh_h	Half drive Ioh ⁵ (ipp_sre[1:0] = 10)	9	35	mA
Iol_h	Half drive Iol ⁵ (ipp_sre[1:0] = 10)	10.5	60	mA

1. Measured when pad = 0 V
2. Measured when pad = V_{DD_HV_IO}
3. Measured when pad is sourcing 2 mA
4. Measured when pad is sinking 2 mA
5. Ioh/Iol is derived from spice simulations. These values are NOT guaranteed by test.

5.2 I/O pad AC specifications

AC Parameters are specified over the full operating junction temperature range of -40°C to +150°C and for the full operating range of the V_{DD_HV_IO} supply defined in [Table 6](#).

Table 13. Functional Pad electrical characteristics

Symbol	Prop. Delay (ns) ¹ L>H/H>L		Rise/Fall Edge (ns) ²		Drive Load (pF)	SIUL2_MSCR[SRC]
	Min	Max	Min	Max		MSB,LSB
pad_sr_hv (output)	2.5/2.5	8.25/7.5	0.7/0.6	3./3	50	11
	6.4/5	19.5/19.5	2.5/2.0	12/12	200	
	2.2/2.5	8/8	0.4/0.3	3.5/3.5	25	10
	2.9/3.5	12.5/11	1.0/0.8	6.5/6.5	50	
	11/8	35/31	6.5/3.0	25/21	200	
	8.3/9.6	45/45	4/3.5	25/25	50	01 ³
	13.5/15	65/65	6.3/6.2	30/30	200	00 ³
	13/13	75/75	6.8/6	40/40	50	
21/22	100/100	11/11	51/51	200		
pad_sr_hv (input) ⁴		2/2		0.5/0.5	0.5	NA

1. As measured from 50% of core side input to Voh/Vol of the output
2. Measured from 20% - 80% of output voltage swing
3. Slew rate control modes
4. Input slope = 2 ns

NOTE

Data based on characterization results, not tested in production.

Table 14. Functional Pad AC Specifications

Symbol	Parameter	Value			Unit
		Min	Typ	Max	
pad_sr_hv(Cp)	Parasitic Input Pin Capacitance	4.5	4.7	5.0	pF

5.3 Aurora LVDS driver electrical characteristics

NOTE

The Aurora interface is AC coupled, so there is no common-mode voltage specification.

Table 15. Aurora LVDS driver electrical characteristics

Symbol	Parameter ¹	Value			Unit
		Min	Typ	Max	
F _{TXRX}	Data rate	—	—	1.15	Gbps
Transmitter Specifications					
V _{diffout}	Differential output voltage swing (terminated)	+/- 400	+/- 600	+/- 800	mV
T _{rise} /T _{fall}	Rise/Fall time (10% - 90% of swing)	60			ps
Receiver Specifications					
V _{diffin}	Differential voltage	+/- 100		+/- 800	mV
Termination					
R _{V_L}	Terminating Resistance (external)	99	100	101	Ohms
C _P	Parasitic Capacitance (pad + bondwire + pin)			1	pF
L _P	Parasitic Inductance			7	nH
STARTUP					
T _{STRT_BIAS}	Bias startup time	—	—	5	μs
T _{STRT_TX}	Transmitter startup time ²	—	—	5	μs
T _{STRT_RX}	Receiver startup time ²	—	—	5	μs
LVDS_RXOUT ³	Receiver o/p duty cycle	30		70	%

1. Conditions for these values are V_{DD_LV_IO_AURORA} = 1.19V to 1.32V, T_J = -40 / 150 °C
2. Startup time is defined as the time taken by LVDS current reference block for settling bias current after its pwr_down (power down) has been deasserted. LVDS functionality is guaranteed only after the startup time.
3. Receiver o/p duty cycle is measured with 1.25 Gbps, 50% duty cycle, max 1 ns rise/fall time, 100 mV voltage swing signal applied at the receiver input.

5.4 Reset pad electrical characteristics

The device implements a dedicated bidirectional RESET_B pin.

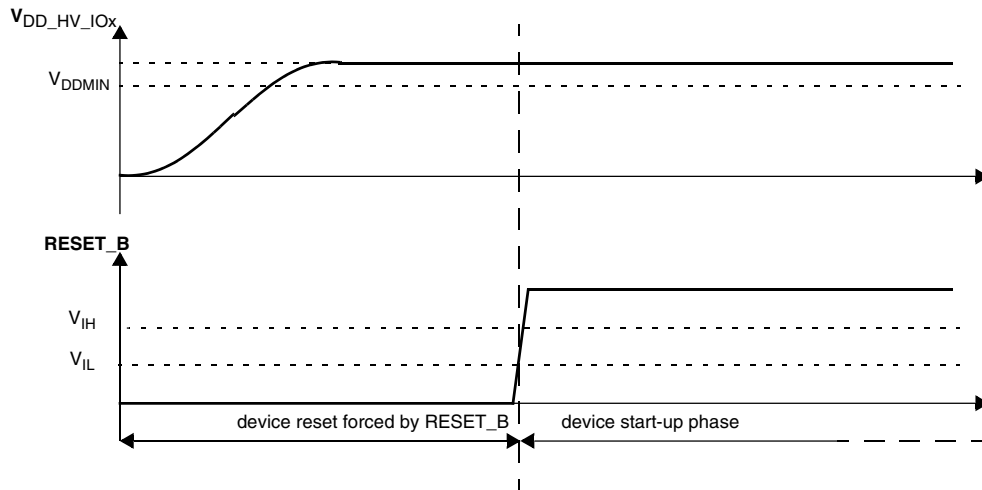

Figure 5. Start-up reset requirements

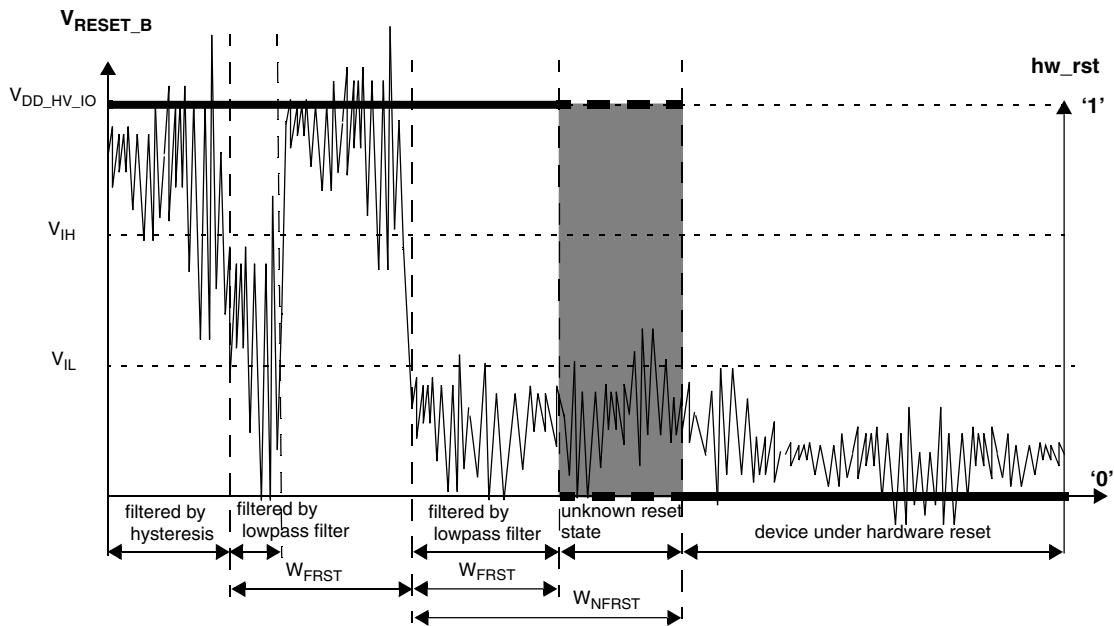

Figure 6. Noise filtering on reset signal

Table 16. RESET_B electrical characteristics

Symbol	Parameter	Conditions ¹	Value			Unit
			Min	Typ	Max	
V _{IH}	Input high level TTL (Schmitt Trigger)	—	2.0	—	V _{DD_HV_IOx} + 0.4	V
V _{IL}	Input low level TTL (Schmitt Trigger)	—	-0.4	—	0.56	V
V _{HYS} ²	Input hysteresis TTL (Schmitt Trigger)	—	300	—	—	mV
I _{OL_R}	Strong pull-down current	Device under power-on reset	0.2	—	—	mA
		V _{DD_HV_IO} = 1.2 V V _{OL} = 0.35 x V _{DD_HV_IO}	15	—	—	mA

Table continues on the next page...

Table 16. RESET_B electrical characteristics (continued)

Symbol	Parameter	Conditions ¹	Value			Unit
			Min	Typ	Max	
		$V_{DD_HV_IO}=3.0\text{ V}$ $V_{OL} = 0.35 \times V_{DD_HV_IO}$				
W_{FRST}	RESET_B input filtered pulse	—	—	—	500	ns
W_{NFRST}	RESET_B input not filtered pulse	—	2400	—	—	ns
I_{WPD}	Weak pull-down current absolute value	$V_{IN} = V_{DD_HV_IOx}$	30	—	100	μA

- $V_{DD_HV_IOx} = 3.3\text{ V} -5\%, +10\%$, $T_J = -40 / 150^\circ\text{C}$, unless otherwise specified.
- Data based on characterization results, not tested in production.

6 Peripheral operating requirements and behaviors

6.1 Clocks and PLL Specifications

6.1.1 40 MHz Oscillator (XOSC) electrical characteristics

The device provides an oscillator/resonator driver.

NOTE

XTAL/EXTAL must not be directly used to drive external circuits.

Table 17. XOSC electrical characteristics

Symbol	Parameter	Conditions	Min	Typ	Max	Unit
$XOSC_{fout}$	Oscillator frequency			40		MHz
t_{stab}	Oscillator start-up time				2	ms
t_{jitcc}	Cycle to cycle jitter (peak – peak)				2.5	ps
	Output Duty Cycle		45	50	55	%
C_{in}	Input Capacitance ¹	Extal and Xtal each	3.0	4.0	5.0	pF
R_{inLVDS}	LVDS bypass mode input termination ²	Between Extal and Xtal	75	100	125	ohm
V_{CMLVDS}	LVDS Common Mode Voltage	$V_{dda}/2$	0.60	0.70	0.80	V

- When using a 40 MHz crystal, the recommended load capacitance is 8 pF. Need quiet ground connection on the board and external crystal/load capacitor placement as close to the Extal and Xtal pins as possible to allow good jitter performance.

- The Termination resistance is only active when the AFE is powered (VDD_HV_RAW, VDD_HV_DAC and the AFE regulators are powered up) and the XOSC is powered down (default case once device is out of reset) or the XOSC is configured in differential bypass mode.

6.1.2 FMPLL electrical characteristics

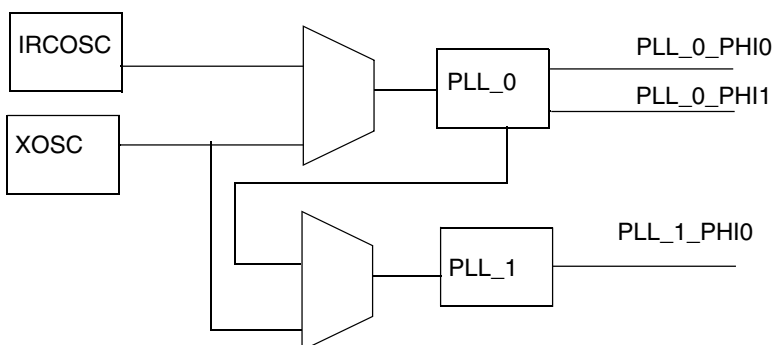

Figure 7. PLL integration

Table 18. PLL0 electrical characteristics

Symbol	Parameter	Conditions ¹	Min	Typ	Max	Unit
f _{PLL0IN}	PLL0 input clock ^{2, 3}	—	14	—	44	MHz
Δ _{PLL0IN}	PLL0 input clock duty cycle ²	—	40	—	60	%
f _{PLL0VCO}	PLL0 VCO frequency	—	600	—	1250	MHz
f _{PLL0PHI0}	PLL0 output clock PHI0	—	4.76	—	625 ⁴	MHz
f _{PLL0PHI1}	PLL0 output clock PHI1	—	20	—	156	MHz
t _{PLL0LOCK}	PLL0 lock time	—	—	—	100	μs
Δ _{PLL0LTJ}	PLL0 long term jitter f _{PLL0IN} = 8 MHz (resonator) ⁵	f _{PLL0PHI0} = 40 MHz, 1 μs	—	—	± 1	ns
		f _{PLL0PHI0} = 40 MHz, 13 μs	—	—	± 1	ns
I _{PLL0}	PLL0 consumption	—	—	—	5	mA

- V_{DD_LV_PLL0} = 1.25 V ± 5%, T_J = -40 / 150 °C unless otherwise specified.
- PLL0IN clock retrieved directly from either IRCOSC or external XOSC clock.
- f_{PLL0IN} frequency must be scaled down using PLLDIG_PLL0DV[PREDIV] to ensure the reference clock to the PLL analog loop is in the range 8 MHz-20 MHz
- The maximum clock outputs are limited by the design clock frequency requirements as per recommended operating conditions.
- V_{DD_LV_PLL0} noise due to application in the range V_{DD_LV_PLL0} = 1.25 V ± 5%, with frequency below PLL bandwidth (40 KHz) will be filtered.

Table 19. FMPLL1 electrical characteristics

Symbol	Parameter	Conditions ¹	Min	Typ	Max	Unit
f _{PLL1IN}	PLL1 input clock ²	—	38	—	78	MHz
Δ _{PLL1IN}	PLL1 input clock duty cycle ²	—	35	—	65	%
f _{PLL1VCO}	PLL1 VCO frequency	—	600	—	1250	MHz
f _{PLL1PHI0}	PLL1 output clock PHI0	—	4.76	—	625	MHz

Table continues on the next page...

Table 19. FMPLL1 electrical characteristics (continued)

Symbol	Parameter	Conditions ¹	Min	Typ	Max	Unit
$t_{PLL1LOCK}$	PLL1 lock time	—	—	—	100	μ s
$f_{PLL1MOD}$	PLL1 modulation frequency	—	—	—	250	kHz
$ \delta_{PLL1MOD} $	PLL1 modulation depth (when enabled)	Center spread	0.25	—	2	%
		Down spread	0.5	—	4	%
I_{PLL1}	PLL1 consumption	—	—	—	6	mA

- $V_{DD_LV_PLL0} = 1.25\text{ V} \pm 5\%$, $T_J = -40 / 150^\circ\text{C}$ unless otherwise specified.
- PLL1IN clock retrieved directly from either internal PLL0 or external XOSC clock.

6.1.3 16 MHz Internal RC Oscillator (IRCOSC) electrical specifications

Table 20. Internal RC Oscillator electrical specifications

Symbol	Parameter	Conditions	Min	Typ	Max	Unit
F_{Target}	IRC target frequency	—	—	16	—	MHz
$F_{untrimmed}$	IRC frequency (untrimmed)	—	9.6	—	24	MHz
δF_{var}	IRC trimmed frequency variation ¹	—	-8	—	8	%
$T_{startup}$	Startup time	—	—	—	5	μ s

- The typical user trim step size (δf_{TRIM}) is +48 KHz for frequencies trimmed above nominal and -40 KHz for frequencies trimmed below nominal.

6.1.4 320 MHz low-jitter PLL electrical characteristics

Table 21. 320 MHz low-jitter PLL parameters

Symbol	Parameter	Conditions	Min	Typ	Max	Unit
PLL_{fout}	Output Frequency		—	320	—	MHz
PLL_{fin}	Input Frequency		—	—	40	MHz
t_{cal}	Calibration Time ¹	LW64 = 1	—	—	150	μ s
		LW64 = 0	—	—	500	
t_{lock}	Lock Time	after calibration	—	—	75	μ s
t_{jitock}	Cycle to cycle jitter (peak – peak)	—	—	—	10	ps
—	Output duty cycle	—	48	50	52	%

- The LW64 bit sets the wait time before the PLL frequency is measured after each calibration step to allow for stabilization. If LW64 is '0', wait time of 256 reference clock cycles is used. If LW64 is '1', wait time of 64 reference clock cycles is used.

7 Analog

7.1 ADC electrical characteristics

The device provides a 12-bit Successive Approximation Register (SAR) Analog-to-Digital Converter.

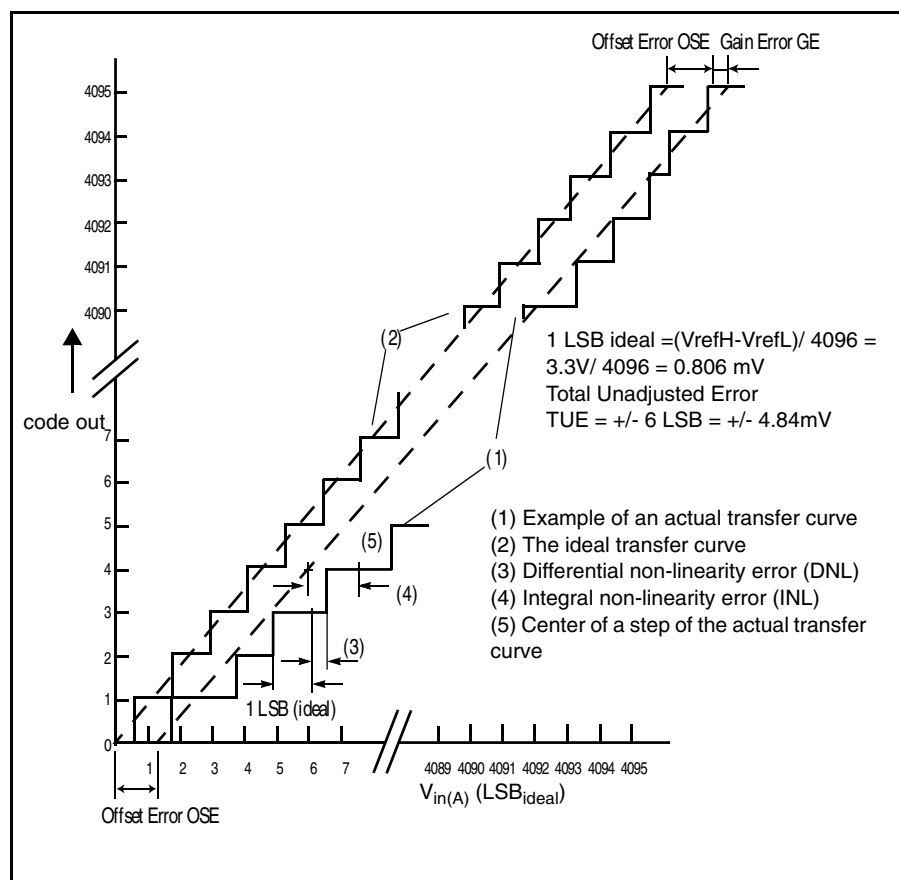

Figure 8. ADC characteristics and error definitions

7.1.1 Input equivalent circuit

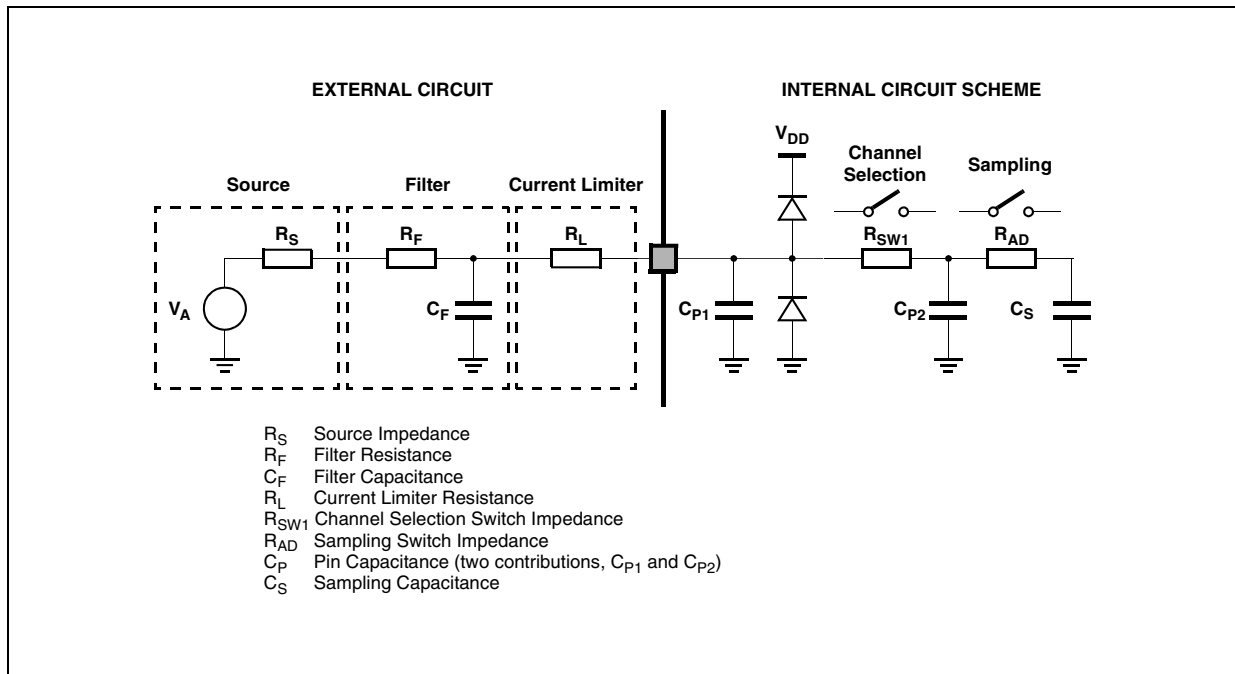

Figure 9. Input equivalent circuit

Table 22. ADC conversion characteristics

Symbol	Parameter	Conditions ¹	Min	Typ	Max	Unit
f_{CK}	ADC Clock frequency (depends on ADC configuration) (The duty cycle depends on AD_CK ² frequency.)	—	20	80	80	MHz
f_s	Sampling frequency	—	—	—	1.00	MHz
t_{sample}	Sample time ³	80 MHz @ 200 ohm source impedance	250	—	—	ns
$t_{sampleC}$	SAR selftest C-algorithm sample time	—	300	—	—	ns
$T_{sampleS}$	SAR selftest S-algorithm sample time	—	1	—	—	μs
$T_{sampleBG}$	Bandgap sample time	—	1.87	—	—	μs
$T_{sampleTS}$	Temperature sensor sample time	—	3.18	—	—	μs
t_{conv}	Conversion time ⁴	80 MHz	675	—	—	ns
C_S ⁵	ADC input sampling capacitance	—	—	3	5	pF
C_{P1} ⁵	ADC input pin capacitance 1	—	—	—	5	pF
C_{P2} ⁵	ADC input pin capacitance 2	—	—	—	0.8	pF
R_{SW1} ⁵	Internal resistance of analog source	V_{REF} range = 3.0 to 3.6 V	—	—	875	Ω
R_{AD} ⁵	Internal resistance of analog source	—	—	—	825	Ω
INL	Integral non-linearity	—	-2	—	2	LSB
DNL	Differential non-linearity ⁶	—	-1	—	1	LSB
OFS	Offset error	—	-4	—	4	LSB
GNE	Gain error	—	-4	—	4	LSB

Table continues on the next page...

Table 22. ADC conversion characteristics (continued)

Symbol	Parameter	Conditions ¹	Min	Typ	Max	Unit
TUE _{IS1WINJ}	Total unadjusted error for IS1WINJ		-6	—	6	LSB
TUE _{IS1WWINJ}	Total unadjusted error for IS1WWINJ		-6	—	6	LSB
IS1WINJ (pad going to one ADC)	(single ADC channel)					
	Max leakage	150 °C	—	—	250	nA
	Max positive/negative injection		-3	—	3 ⁸	mA
IS1WWINJ (pad going to two ADCs)	(double ADC channel)					
	Max leakage	150 °C	—	—	300	nA
	Max positive/negative injection ⁷	Vref_ad0 - Vref_ad1 < 150 mV	-3.6	—	3.6	mA
SNR	Signal-to-noise ratio	3.3 V reference voltage	67	—	—	dB
THD	Total harmonic distortion	@ 50 KHz	65	—	—	dB
SINAD	Signal-to-noise and distortion	Fin < 50 KHz	6.02 x ENOB + 1.76			dB
ENOB	Effective number of bits	Fin < 50 KHz	10.5	—	—	bits

1. $V_{DD_HV_ADC} = 3.3\text{ V} -5\%, +10\%$, $T_J = -40\text{ to }+150\text{ °C}$, unless otherwise specified and analog input voltage from V_{AGND} to $V_{DD_HV_ADCREFX}$.
2. AD_CK clock is always half of the ADC module input clock defined via the auxiliary clock divider for the ADC.
3. During the sample time the input capacitance C_S can be charged/discharged by the external source. The internal resistance of the analog source must allow the capacitance to reach its final voltage level within t_{sample} . After the end of the sample time t_{sample} , changes of the analog input voltage have no effect on the conversion result. Values for the sample clock t_{sample} depend on programming.
4. This parameter does not include the sample time t_{sample} , but only the time for determining the digital result and the time to load the result register with the conversion result.
5. See [Figure 9](#)
6. No missing codes.
7. ADC specifications are met only if injection is within these specified limits
8. Max injection current for all ADC IOs is $\pm 10\text{ mA}$

NOTE

The ADC performance specifications are not guaranteed if two ADCs simultaneously sample the same shared channel. Aurora interface along with SAR-ADC would degrade SAR-ADC performance. General Purpose Input (GPI) functionality should not be used on any of the SAR-ADC channels when SARADC is functional.

8 Memory modules

8.1 Flash memory program and erase specifications

NOTE

All timing, voltage, and current numbers specified in this section are defined for a single embedded flash memory within

an SoC, and represent average currents for given supplies and operations.

Table 23 shows the estimated Program/Erase times.

Table 23. Flash memory program and erase specifications

Symbol	Characteristic ¹	Typ ²	Factory Programming ^{3,4}		Field Update			Unit
			Initial Max	Initial Max, Full Temp	Typical End of Life ⁵	Lifetime Max ⁶		
			20°C ≤ T _A ≤ 30°C	-40°C ≤ T _J ≤ 150°C	-40°C ≤ T _J ≤ 150°C	≤ 1,000 cycles	≤ 250,000 cycles	
t _{dwp_{pgm}}	Doubleword (64 bits) program time	43	100	150	55	500		μs
t _{pp_{pgm}}	Page (256 bits) program time	73	200	300	108	500		μs
t _{qpp_{pgm}}	Quad-page (1024 bits) program time	268	800	1,200	396	2,000		μs
t _{16_{kers}}	16 KB Block erase time	168	290	320	250	1,000		ms
t _{16_{kpgm}}	16 KB Block program time	34	45	50	40	1,000		ms
t _{32_{kers}}	32 KB Block erase time	217	360	390	310	1,200		ms
t _{32_{kpgm}}	32 KB Block program time	69	100	110	90	1,200		ms
t _{64_{kers}}	64 KB Block erase time	315	490	590	420	1,600		ms
t _{64_{kpgm}}	64 KB Block program time	138	180	210	170	1,600		ms
t _{256_{kers}}	256 KB Block erase time	884	1,520	2,030	1,080	4,000	—	ms
t _{256_{kpgm}}	256 KB Block program time	552	720	880	650	4,000	—	ms

1. Program times are actual hardware programming times and do not include software overhead. Block program times assume quad-page programming.
2. Typical program and erase times represent the median performance and assume nominal supply values and operation at 25 °C. Typical program and erase times may be used for throughput calculations.
3. Conditions: ≤ 150 cycles, nominal voltage.
4. Plant Programming times provide guidance for timeout limits used in the factory.
5. Typical End of Life program and erase times represent the median performance and assume nominal supply values. Typical End of Life program and erase values may be used for throughput calculations.
6. Conditions: -40°C ≤ T_J ≤ 150°C, full spec voltage.

8.2 Flash memory Array Integrity and Margin Read specifications

Table 24. Flash memory Array Integrity and Margin Read specifications

Symbol	Characteristic	Min	Typical	Max ¹	Units ²
t _{ai16_{kseq}}	Array Integrity time for sequential sequence on 16 KB block.	—	—	512 x T _{period} x N _{read}	—

Table continues on the next page...

Table 24. Flash memory Array Integrity and Margin Read specifications (continued)

Symbol	Characteristic	Min	Typical	Max ¹	Units ²
$t_{ai32kseq}$	Array Integrity time for sequential sequence on 32 KB block.	—	—	1024 x Tperiod x Nread	—
$t_{ai64kseq}$	Array Integrity time for sequential sequence on 64 KB block.	—	—	2048 x Tperiod x Nread	—
$t_{ai256kseq}$	Array Integrity time for sequential sequence on 256 KB block.	—	—	8192 x Tperiod x Nread	—
$t_{mr16kseq}$	Margin Read time for sequential sequence on 16 KB block.	73.81	—	110.7	μ s
$t_{mr32kseq}$	Margin Read time for sequential sequence on 32 KB block.	128.43	—	192.6	μ s
$t_{mr64kseq}$	Margin Read time for sequential sequence on 64 KB block.	237.65	—	356.5	μ s
$t_{mr256kseq}$	Margin Read time for sequential sequence on 256 KB block.	893.01	—	1,339.5	μ s

1. Array Integrity times need to be calculated and is dependent on system frequency and number of clocks per read. The equation presented require Tperiod (which is the unit accurate period, thus for 200 MHz, Tperiod would equal 5e-9) and Nread (which is the number of clocks required for read, including pipeline contribution. Thus for a read setup that requires 6 clocks to read with no pipeline, Nread would equal 6. For a read setup that requires 6 clocks to read, and has the address pipeline set to 2, Nread would equal 4 (or 6 - 2).)
2. The units for Array Integrity are determined by the period of the system clock. If unit accurate period is used in the equation, the results of the equation are also unit accurate.

8.3 Flash memory module life specifications

Table 25. Flash memory module life specifications

Symbol	Characteristic	Conditions	Min	Typical	Units
Array P/E cycles	Number of program/erase cycles per block for 16 KB, 32 KB and 64 KB blocks. ¹	—	250,000	—	P/E cycles
	Number of program/erase cycles per block for 256 KB blocks. ²	—	1,000	250,000	P/E cycles
Data retention	Minimum data retention.	Blocks with 0 - 1,000 P/E cycles.	50	—	Years
		Blocks with 100,000 P/E cycles.	20	—	Years
		Blocks with 250,000 P/E cycles.	10	—	Years

1. Program and erase supported across standard temperature specs.
2. Program and erase supported across standard temperature specs.

8.4 Data retention vs program/erase cycles

Graphically, Data Retention versus Program/Erase Cycles can be represented by the following figure. The spec window represents qualified limits. The extrapolated dotted line demonstrates technology capability, however is beyond the qualification limits.

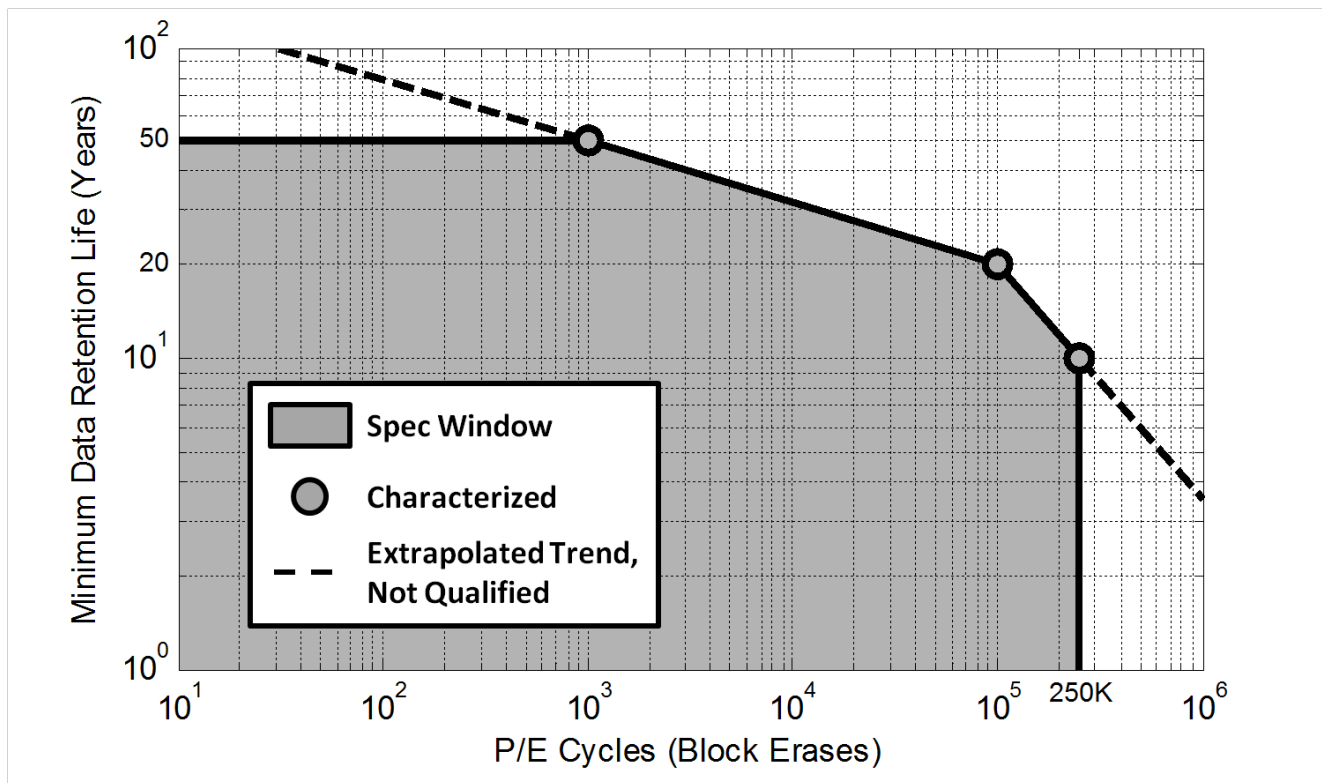

8.5 Flash memory AC timing specifications

Table 26. Flash memory AC timing specifications

Symbol	Characteristic	Min	Typical	Max	Units
t _{psus}	Time from setting the MCR-PSUS bit until MCR-DONE bit is set to a 1.	—	9.4 plus four system clock periods	11.5 plus four system clock periods	μs
t _{esus}	Time from setting the MCR-ESUS bit until MCR-DONE bit is set to a 1.	—	16 plus four system clock periods	20.8 plus four system clock periods	μs

Table continues on the next page...

Table 26. Flash memory AC timing specifications (continued)

Symbol	Characteristic	Min	Typical	Max	Units
t_{res}	Time from clearing the MCR-ESUS or PSUS bit with EHV = 1 until DONE goes low.	—	—	100	ns
t_{done}	Time from 0 to 1 transition on the MCR-EHV bit initiating a program/erase until the MCR-DONE bit is cleared.	—	—	5	ns
t_{dones}	Time from 1 to 0 transition on the MCR-EHV bit aborting a program/erase until the MCR-DONE bit is set to a 1.	—	16 plus four system clock periods	20.8 plus four system clock periods	μ s
t_{drcv}	Time to recover once exiting low power mode.	16 plus seven system clock periods.	—	45 plus seven system clock periods	μ s
$t_{aistart}$	Time from 0 to 1 transition of UT0-AIE initiating a Margin Read or Array Integrity until the UT0-AID bit is cleared. This time also applies to the resuming from a suspend or breakpoint by clearing AISUS or clearing NAIBP	—	—	5	ns
t_{aistop}	Time from 1 to 0 transition of UT0-AIE initiating an Array Integrity abort until the UT0-AID bit is set. This time also applies to the UT0-AISUS to UT0-AID setting in the event of a Array Integrity suspend request.	—	—	80 plus fifteen system clock periods	ns
t_{mrstop}	Time from 1 to 0 transition of UT0-AIE initiating a Margin Read abort until the UT0-AID bit is set. This time also applies to the UT0-AISUS to UT0-AID setting in the event of a Margin Read suspend request.	10.36 plus four system clock periods	—	20.42 plus four system clock periods	μ s

8.6 Flash memory read wait-state and address-pipeline control settings

The following table describes the recommended settings of the Flash Memory Controller's PFCR1,2,3[RWSC] and PCRC1,2,3[APC] fields at various operating frequencies, based on specified intrinsic flash memory access timed of the Flash memory.

Table 27. Flash read wait state and address pipeline control guidelines

Operating frequency (fsys)	RWSC	APC	Flash read latency on mini-cache miss (# of sys clock periods)	Flash read latency on mini-cache hit (# of sys clock periods)
100 MHz	2	1	5	1
120 MHz	3	1	6	1

9 Communication modules

9.1 SPI timing specifications

The following table describes the SPI electrical characteristics.

MTEF=1 Mode timing values given below are only applicable when external SPI is in classic mode. Slave mode timing values given below are applicable when device is in MTFE=0.

- Measurements are with maximum output load of 50 pF, input transition of 1 ns and pad configured as SRE = 11.

Table 28. SPI timing

No.	Symbol	Parameter	Conditions	Min	Max	Unit
1	t_{SCK}	SPI cycle time	Master (MTFE = 0)	50	—	ns
			Master (MTFE = 1)	50	—	
			Slave (MTFE = 0)	50	—	
			Slave Receive Only mode ¹	16	—	
2	t_{CSC}	PCS to SCK delay	Master	63.8 ²	—	ns
3	t_{ASC}	After SCK delay	Master	68.8 ³	—	ns
4	t_{SDC}	SCK duty cycle	Master ⁴	$t_{SCK}/2 - 1$	$t_{SCK}/2 + 1$	ns
			Slave ⁵	—	—	ns
			Slave Receive only mode ⁶	$t_{SCK}/2 - 0.750$	$t_{SCK}/2 + 0.750$	ns
5	t_A	Slave access time	\overline{SS} active to SOUT valid	—	25	ns
6	t_{DIS}	Slave SOUT disable time	\overline{SS} inactive to SOUT High-Z or invalid	—	25	ns
7	t_{PCSC}	PCSx to \overline{PCSS} time	—	13 ⁷	—	ns
8	t_{PASC}	\overline{PCSS} to PCSx time	—	13 ⁸	—	ns
9	t_{SUI}	Data setup time for inputs	Master (MTFE = 0)	15	—	ns
			Slave	2	—	
			Slave Receive Mode	2	—	
			Master (MTFE = 1, CPHA = 0) ⁹	15-N x SPI IPG clock period ¹⁰	—	
			Master (MTFE = 1, CPHA = 1)	15	—	
10	t_{HI}	Data hold time for inputs	Master (MTFE = 0)	-2	—	ns
			Slave	4	—	
			Slave Receive Mode	4	—	
			Master (MTFE = 1, CPHA = 0) ⁹	-2 + N x SPI IPG clock period ¹⁰	—	

Table continues on the next page...

Table 28. SPI timing (continued)

No.	Symbol	Parameter	Conditions	Min	Max	Unit
			Master (MTFE = 1, CPHA = 1)	-2	—	
11	t_{SU0}	Data valid (after SCK edge)	Master (MTFE = 0)	—	7 ¹¹	ns
			Slave	—	23	
			Master (MTFE = 1, CPHA = 0) ¹²	—	7 + SPI IPG Clock Period	
			Master (MTFE = 1, CPHA = 1)	—	7	
12	t_{HO}	Data hold time for outputs	Master (MTFE = 0)	-4 ¹¹	—	ns
			Slave	3.8	—	
			Master (MTFE = 1, CPHA = 0) ¹²	-4 + SPI IPG Clock Period	—	
			Master (MTFE = 1, CPHA = 1)	-4	—	

- Slave Receive Only mode can operate at a maximum frequency of 60 MHz. In this mode, the SPI can receive data on SIN, but no valid data is transmitted on SOUT.
- For SPI_CTARn[PCSSCK] - 'PCS to SCK Delay Prescaler' configuration is '3' (01h) and SPI_CTARn[CSSCK] - 'PCS to SCK Delay Scaler' configuration is '2' (0000h).
- For SPI_CTARn[PASC] - 'After SCK Delay Prescaler' configuration is '3' (01h) and SPI_CTARn[ASC] - 'After SCK Delay Scaler' configuration is '2' (0000h).
- The numbers are valid when SPI is configured for 50/50. Refer the Reference manual for the mapping of the duty cycle to each configuration. A change in duty cycle changes the parameter here. For example, a configuration providing duty cycle of 33/66 at SPI translates to min $t_{SCK}/3 - 1.5$ ns and max $t_{SCK}/3 + 1.5$ ns.
- The slave mode parameters (t_{SUI} , t_{HI} , t_{SU0} and t_{HO}) assume 50% duty cycle on SCK input. Any change in SCK duty cycle input must be taken care during the board design or by the master timing.
- The slave receive only mode parameters (t_{SUI} and t_{HI}) assume 50% duty cycle on SCK input. Any change in SCK duty cycle input must be taken care during the board design or by the master timing. However, there is additional restriction in the slave receive only mode that the duty cycle at the slave input should not go below $t_{sdc}(\text{min})$ corresponding to the $t_{sdc}(\text{min})$ for the slave receive mode.
- In the master mode, this is governed by t_{PCSSCK} . Refer the SPI chapter in the Reference Manual for details. The minimum spec is valid only for SPI_CTARn[PCSSCK]= '0b01' (PCS to SCK delay prescaler of 3) or higher.
- In the master mode, this is governed by t_{PASC} . Refer the SPI chapter in the Reference Manual for details. The minimum spec is valid only for SPI_CTARn[PASC]= '0b01' (after SCK delay prescaler of 3) or higher.
- For SPI_CTARn[BR] - 'Baud Rate Scaler' configuration is ≥ 4 .
- N = Configured sampling point value in MTFE=1 Mode.
- Same value is applicable for PCS timing in continuous SCK mode.
- SMPL_PTR should be set to 1.

NOTE

For numbers shown in the following figures, see [Table 28](#).

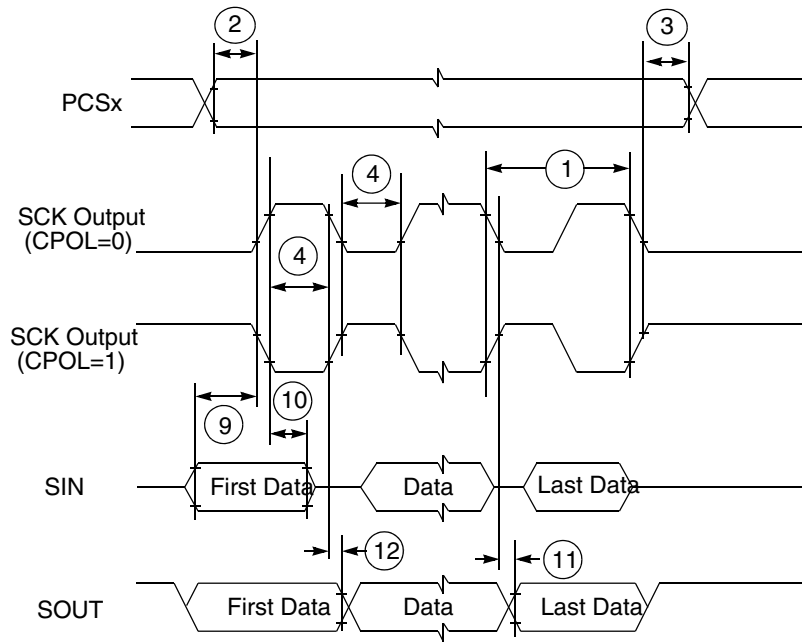

Figure 10. SPI classic SPI timing — master, CPHA = 0

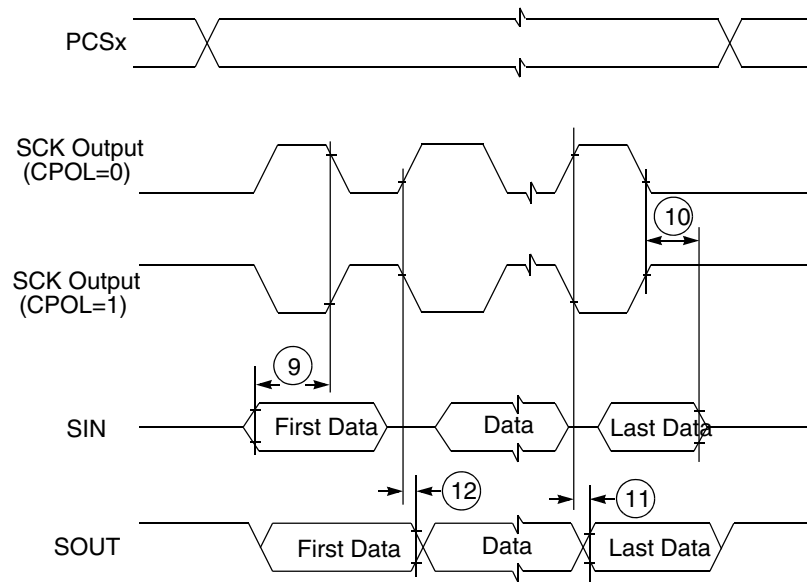

Figure 11. SPI classic SPI timing — master, CPHA = 1

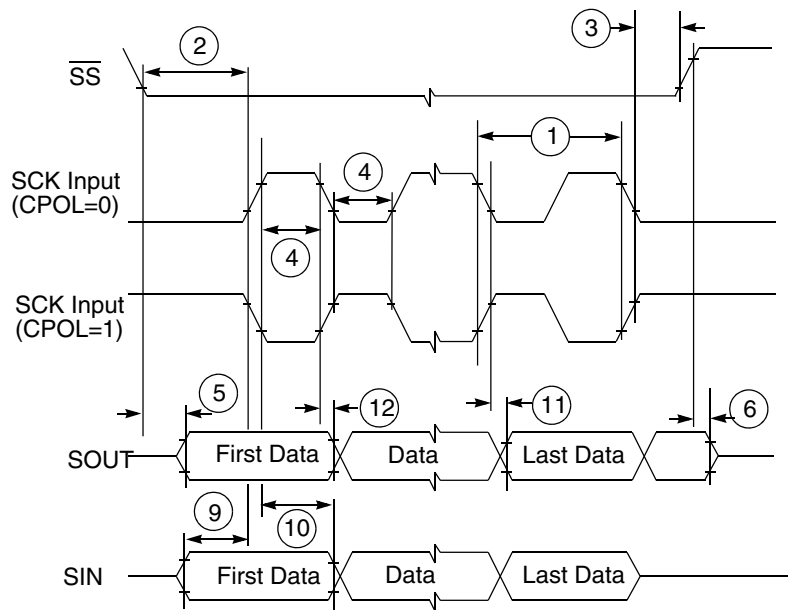

Figure 12. SPI classic SPI timing — slave, CPHA = 0

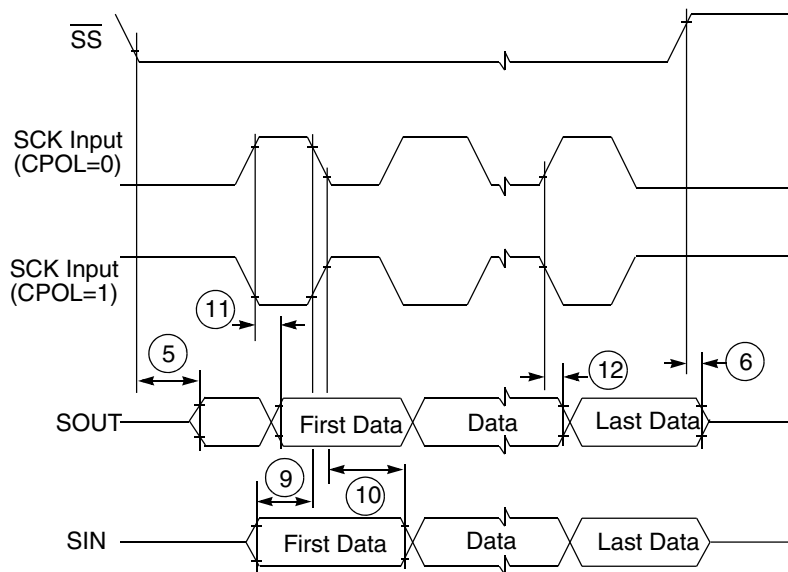

Figure 13. SPI classic SPI timing — slave, CPHA = 1

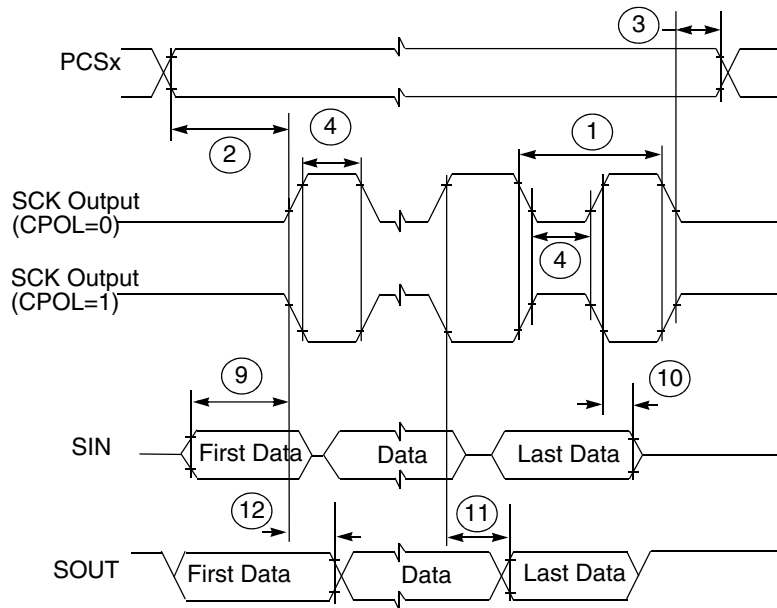

Figure 14. SPI modified transfer format timing — master, CPHA = 0

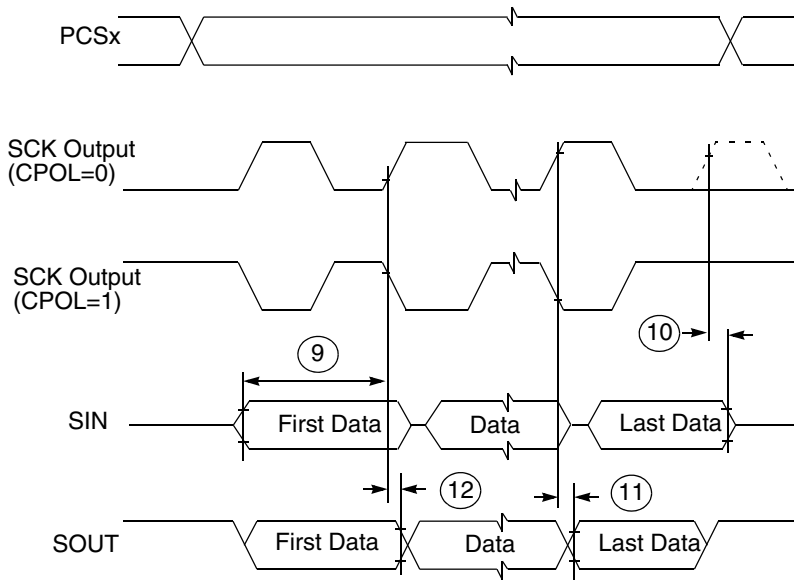

Figure 15. SPI modified transfer format timing — master, CPHA = 1

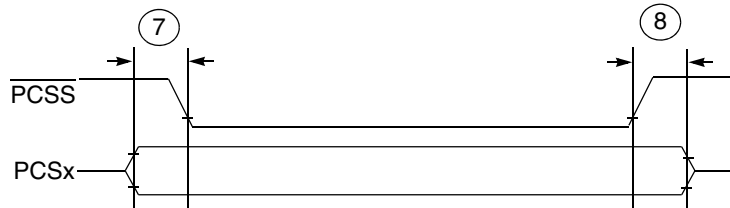

Figure 16. SPI PCS strobe (PCSS) timing

9.2 LINFlexD timing specifications

The maximum bit rate is 1.875 MBit/s.

9.3 I²C timing

Table 29. I²C SCL and SDA input timing specifications

Number	Symbol	Parameter	Value		Unit
			Min	Max	
1	I_tHD:STA	Start Condition hold time	2	-	Peripheral clock
2	I_t_LOW	Clock low time	8	-	
3	I_tHD:DAT	Data hold time	2	-	
4	I_tHIGH	Clock high time	4	-	
5	I_tSU:DAT	Data setup time	4	-	
6	I_tSU:STA	Start condition setup time (for repeated start condition only)	2	-	
7	I_tSU:STOP	Stop condition setup time	2	-	

Table 30. I²C SCL and SDA output timing specifications

Number	Symbol	Parameter	Value		Unit
			Min	Max	
1	O_tHD:STA	Start condition hold time ¹	6	-	Peripheral clock
2	O_t_LOW	Clock low time ¹	10	-	
3	O_tHD:DAT	Data hold time ¹	7	-	
4	O_t_HIGH	Clock high time ¹	10	-	
5	O_tSU:DAT	Data setup time ¹	2	-	
6	O_tSU:STA	Start condition setup time (for repeated start condition only) ¹	20	-	
7	O_tSU:STOP	Stop condition setup time ¹	10	-	
8	O_tr	SCL/SDA rise time ²	-	99.6	ns
9	O_tf	SCL/SDA fall time ¹	-	99.6	

1. Programming IBFD (I²C Bus Frequency Divider Register) with the maximum frequency results in the minimum output timings listed. The I²C interface is designed to scale the data transition time, moving it to the middle of the SCL low period. The actual position is affected by the prescale and division values programmed in IBDR (I²C Bus Data I/O Register).
2. Serial data (SDA) and Serial clock (SCL) reaches peak level depending upon the external signal capacitance and pull up resistor values as SDA and SCL are open-drain type outputs which are only actively driven low by the I²C module.

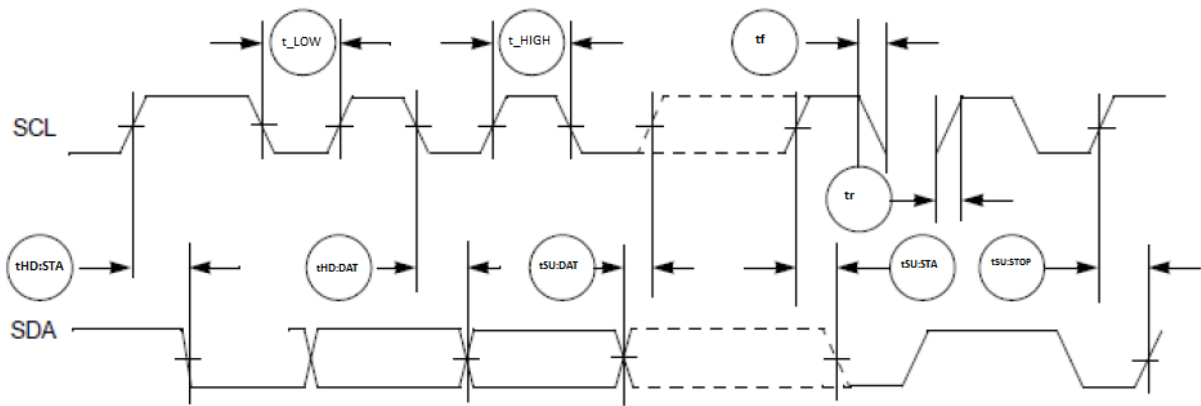

Figure 17. I²C input/output timing

10 Debug modules

10.1 JTAG/CJTAG interface timing

The following table lists JTAGC/CJTAG electrical characteristics.

- Measurements are with input transition of 1 ns, output load of 50 pF and pads configured with SRE=11.

Table 31. JTAG/CJTAG pin AC electrical characteristics ¹

#	Symbol	Characteristic	Min	Max	Unit
1	t_{CYC} ²	TCK Cycle Time (JTAG)	36	—	ns
		TCK Cycle Time (CJTAG)	50		
2	t_{JDC}	TCK Clock Pulse Width	40	60	%
3	$t_{TCKRISE}$	TCK Rise and Fall Times (40% - 70%)	—	3	ns
4	t_{TMSS}, t_{TDIS}	TMS, TDI Data Setup Time	5	—	ns
5	t_{TMSH}, t_{TDIH}	TMS, TDI Data Hold Time	5	—	ns
6	t_{TDOV}	TCK Low to TDO/TMS Data Valid ³	—	15 ⁴	ns
7	t_{TDOI}	TCK Low to TDO/TMS Data Invalid ³	0	—	ns
8	t_{TDOHZ}	TCK Low to TDO/TMS High Impedance ³	—	22	ns
9	t_{JCMPPW}	JCOMP Assertion Time	100	—	ns
10	t_{JCMPS}	JCOMP Setup Time to TCK Low	40	—	ns

Table continues on the next page...

Table 31. JTAG/CJTAG pin AC electrical characteristics ¹ (continued)

#	Symbol	Characteristic	Min	Max	Unit
11	t_{BSDV}	TCK Falling Edge to Output Valid	—	600 ⁵	ns
12	t_{BSDVZ}	TCK Falling Edge to Output Valid out of High Impedance	—	600	ns
13	t_{BSDHZ}	TCK Falling Edge to Output High Impedance	—	600	ns
14	t_{BSDST}	Boundary Scan Input Valid to TCK Rising Edge	15	—	ns
15	t_{BSDHT}	TCK Rising Edge to Boundary Scan Input Invalid	15	—	ns

1. These specifications apply to JTAG boundary scan only.
2. This timing applies to TDI, TDO, TMS pins, however, actual frequency is limited by pad type for EXTEST instructions. Refer to pad specification for allowed transition frequency
3. TMS timing is applicable only in CJTAG mode
4. Timing includes TCK pad delay, clock tree delay, logic delay and TDO output pad delay.
5. Applies to all pins, limited by pad slew rate. Refer to IO delay and transition specification and add 20 ns for JTAG delay.

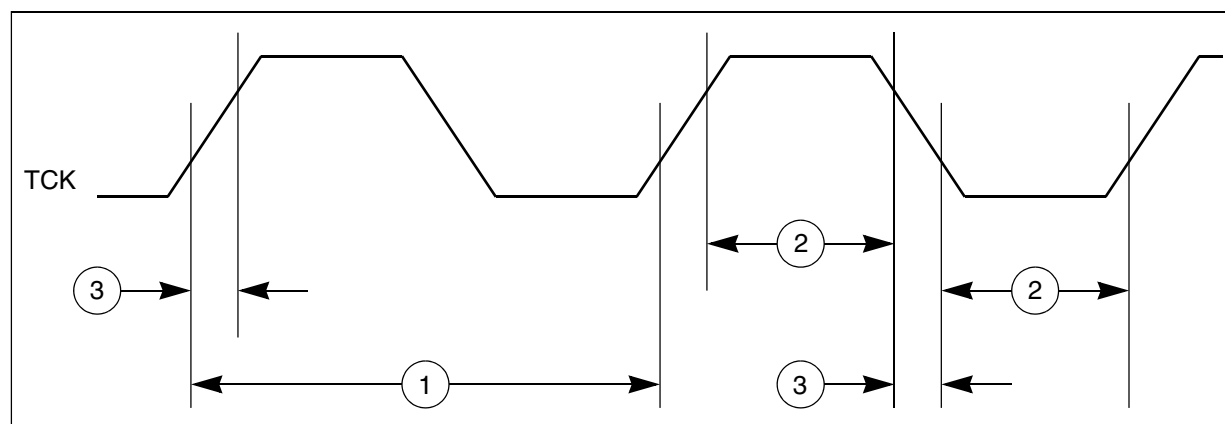

Figure 18. JTAG test clock input timing

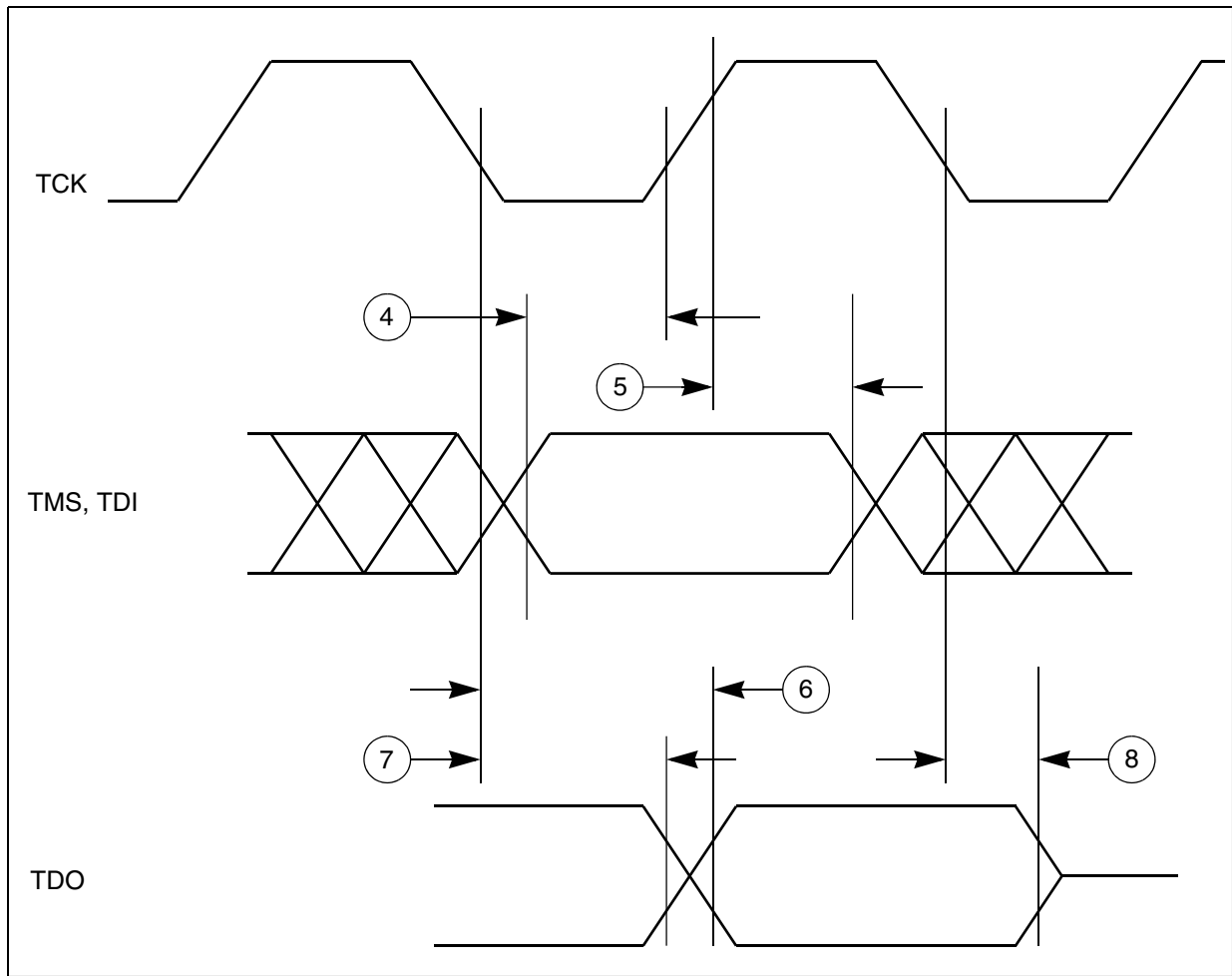

Figure 19. JTAG test access port timing

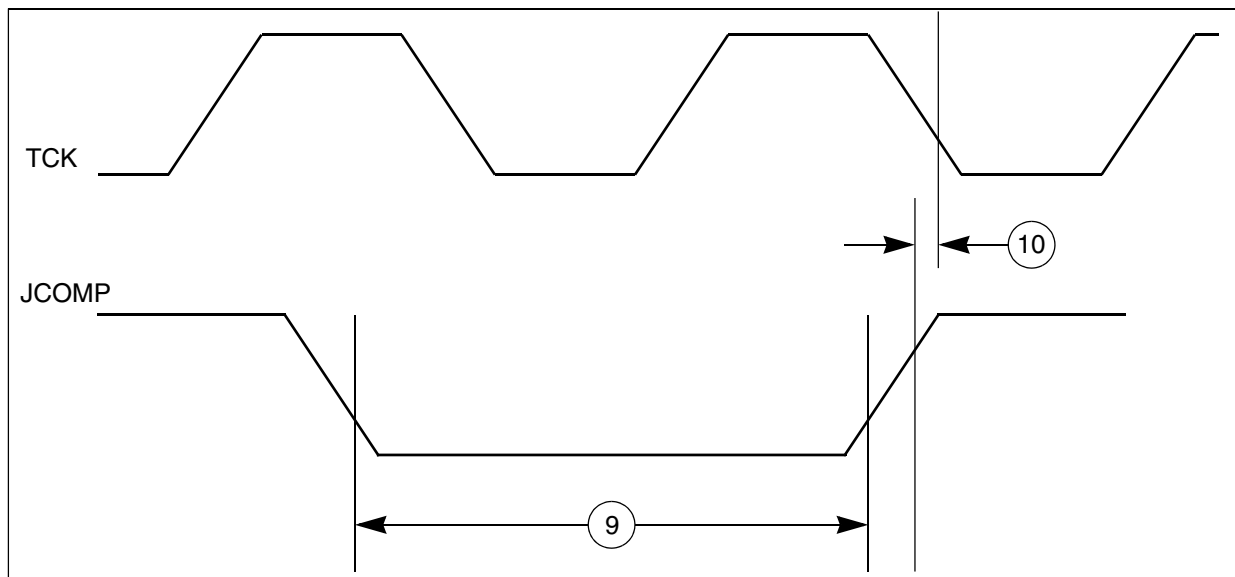

Figure 20. JTAG JCOMP timing

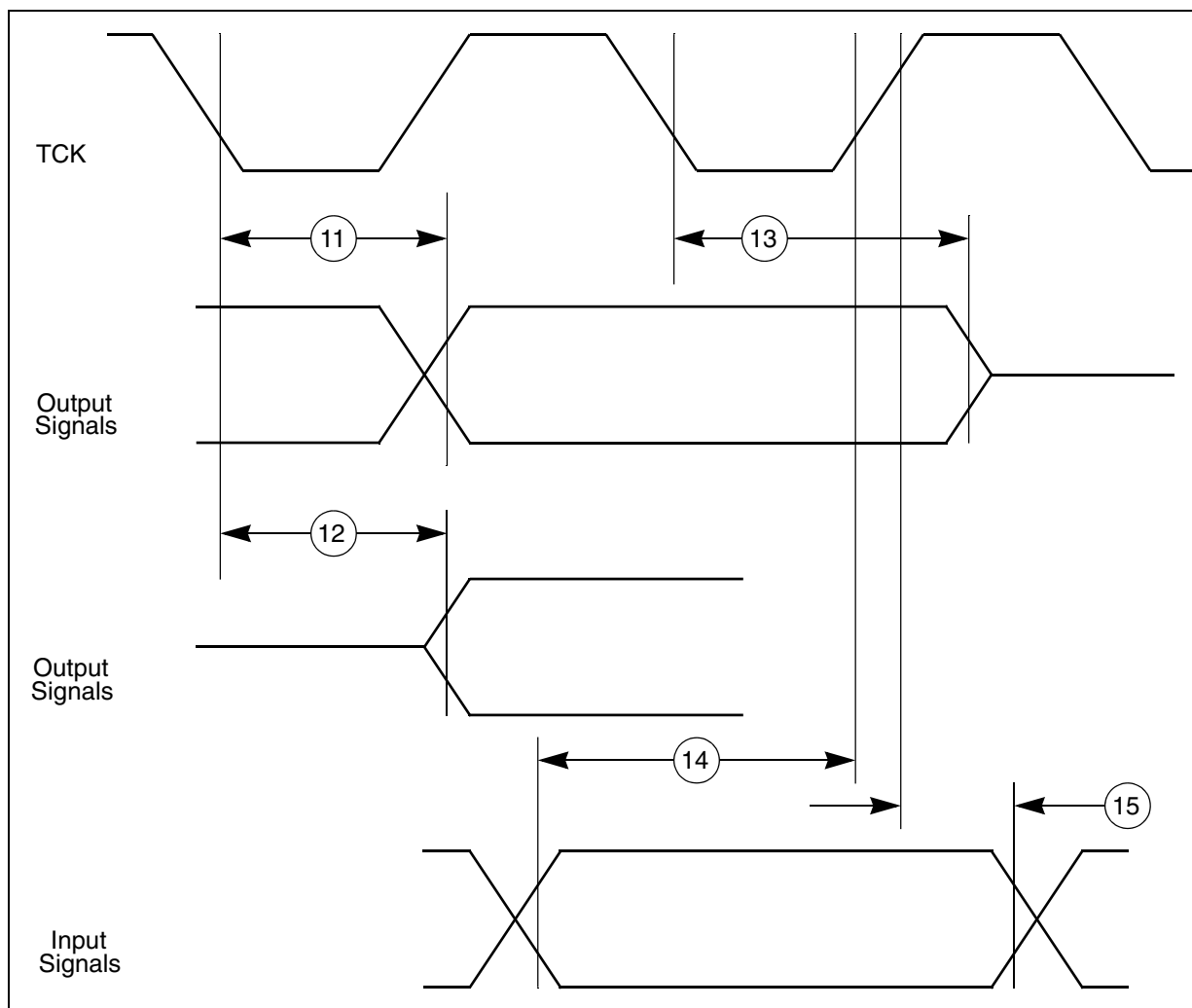

Figure 21. JTAG boundary scan timing

10.2 Nexus Aurora debug port timing

Table 32. Nexus Aurora debug port timing

#	Symbol	Characteristic	Min	Max	Unit
1	t_{REFCLK}	Reference clock frequency	625	1250	MHz
1a	t_{MCYC}	Reference Clock high/low time	—	400	ps
2	t_{RCDC}	Reference Clock Duty Cycle	45	55	%
3	J_{RC}	Reference Clock jitter	—	40	ps
4	$t_{STABILITY}$	Reference Clock Stability	50	—	PPM
5	BER	Bit Error Rate	—	10^{-12}	—
6	t_{EVTIPW}	EVTI Pulse Width	4.0	—	t_{TCYC}
7	J_D	Transmit lane Deterministic Jitter	—	0.17	OUI
8	J_T	Transmit lane Total Jitter	—	0.35	OUI

Table continues on the next page...

Table 32. Nexus Aurora debug port timing (continued)

#	Symbol	Characteristic	Min	Max	Unit
9	S _O	Differential output skew	—	20	ps
10	S _{MO}	Lane to lane output skew	—	1000	ps
11	OUI	Aurora lane Unit Interval	800	800	ps

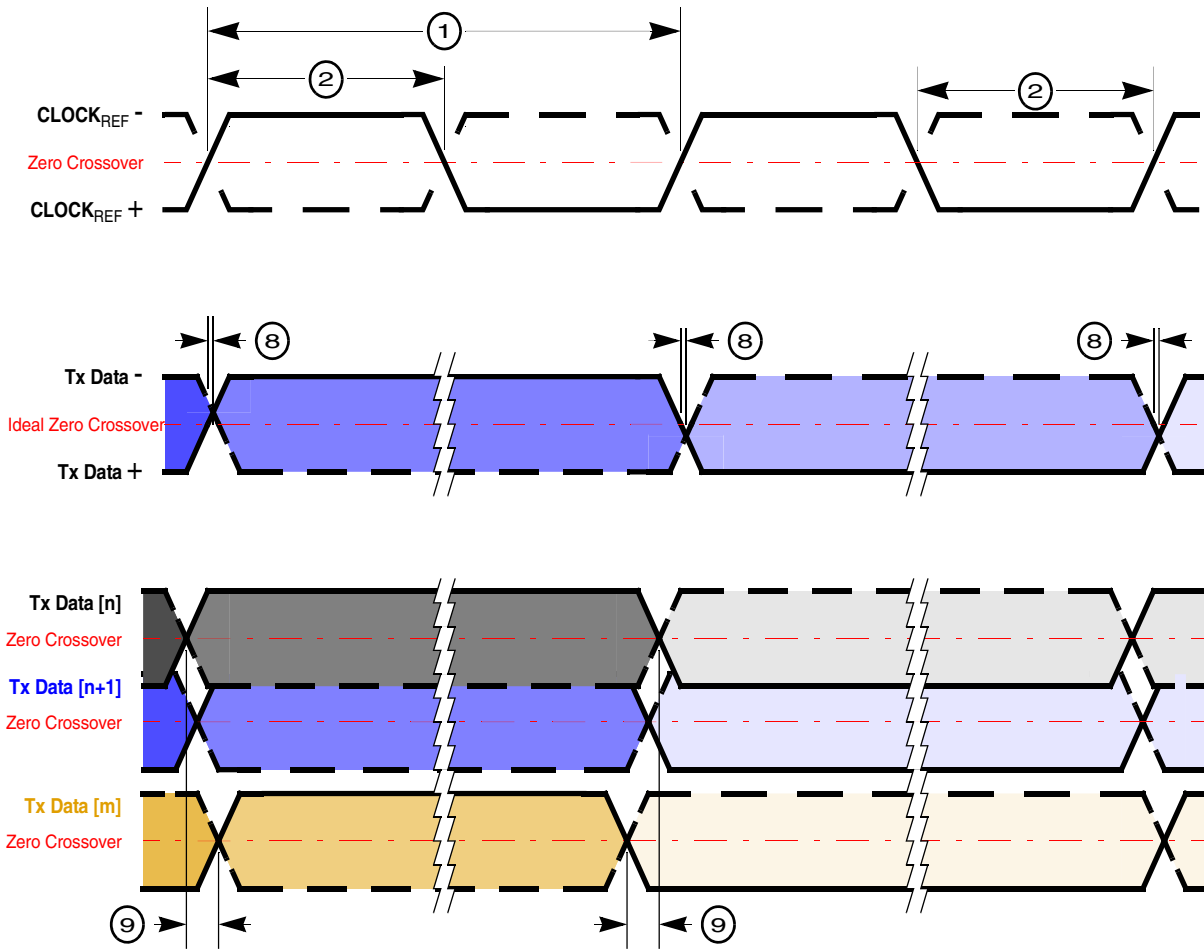

Figure 22. Nexus Aurora timings

11 WKPU/NMI timing specifications

Table 33. WKPU/NMI glitch filter

Symbol	Parameter	Min	Typ	Max	Unit
W _{FNMI}	NMI pulse width that is rejected	—	—	20	ns
W _{NFNMI}	NMI pulse width that is passed	400	—	—	ns

12 External interrupt timing (IRQ pin)

Table 34. External interrupt timing

No.	Symbol	Parameter	Conditions	Min	Max	Unit
1	t_{IPWL}	IRQ pulse width low	—	3	—	t_{CYC}
2	t_{IPWH}	IRQ pulse width high	—	3	—	t_{CYC}
3	t_{ICYC}	IRQ edge to edge time ¹	—	6	—	t_{CYC}

1. Applies when IRQ pins are configured for rising edge or falling edge events, but not both

NOTE

t_{CYC} is equivalent to TCK (prescaled filter clock period) which is the IRC clock prescaled to the Interrupt Filter Clock Prescaler (IFCP) value. $TCK = T(IRC) \times (IFCP + 1)$ where $T(IRC)$ is the internal oscillator period. Refer SIUL2 chapter of the reference manual for details.

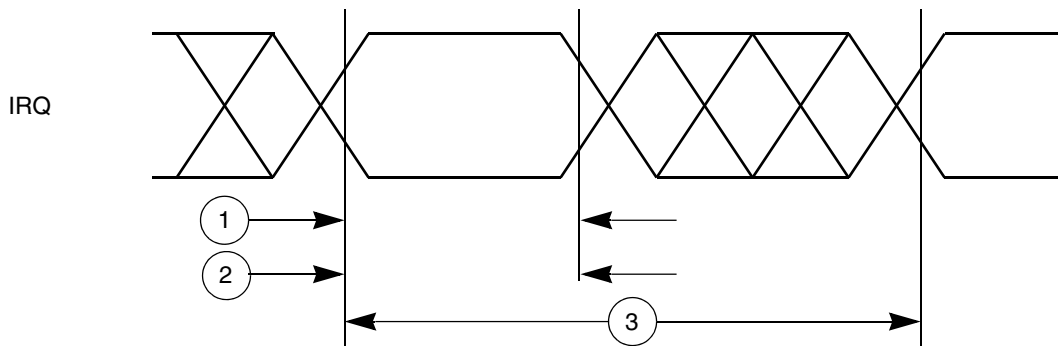

Figure 23. External interrupt timing

13 Temperature sensor electrical characteristics

The following table describes the temperature sensor electrical characteristics.

Table 35. Temperature sensor electrical characteristics

Symbol	Parameter	Conditions	Min	Typ	Max	Unit
—	Temperature monitoring range		-40	—	150	$^{\circ}\text{C}$
T_{SENS}	Sensitivity		—	5.18	—	$\text{mV}/^{\circ}\text{C}$
T_{ACC}	Accuracy	$T_J = -40$ to 150°C	5	—	5	$^{\circ}\text{C}$

14 Radar module

14.1 MIPICSI2 D-PHY electrical and timing specifications

This section describes MIPICSI2¹ D-PHY electrical specifications, compliant with MIPICSI2 version 1.1, D-PHY specification Rev. 1.0 (for MIPI sensor port x2 lanes).

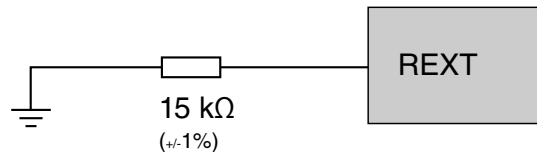

Figure 24. MIPICSI2 circuit

Table 36. Calibrator specifications

Symbol	Parameters	Min	Typ	Max	Unit
R _{EXT}	External reference resistor, 1% accuracy (or better), for auto calibration	-	15	-	kΩ
T _{cal}	Time from when PD signal goes low to when CALCOMPL goes high	-	2.5	4.2	μs

14.1.1 Electrical and timing information

Table 37. Electrical and timing information

Symbol	Parameters	Min	Typ	Max	Unit
HS Line Receiver DC Specifications					
V _{IDTH}	Differential input high voltage threshold	-	-	70	mV
V _{IDTL}	Differential input low voltage threshold	-70	-	-	mV
V _{IHHS}	Single ended input high voltage	-	-	460	mV
V _{ILHS}	Single ended input low voltage	-40	-	-	mV
V _{CMRXDC}	Input common mode voltage	70	-	330	mV
V _{TERM-EN}	Single-ended threshold for HS termination enable	-	-	450	mV
Z _{ID}	Differential input impedance	80	-	125	ohm
LP Line Receiver DC Specifications					
V _{ILLP}	Input low voltage	-	-	550	mV

Table continues on the next page...

1. All rights reserved. This material is reprinted with the permission of the MIPI Alliance, Inc. No part(s) of this document may be disclosed, reproduced or used for any purpose other than as needed to support the use of the products of NXP Semiconductors.

Table 37. Electrical and timing information (continued)

Symbol	Parameters	Min	Typ	Max	Unit
V_{IHLP}	Input high voltage	880	-	-	mV
V_{HYST}	Input hysteresis	25	-	-	mV

14.1.2 D-PHY signaling levels

The signal levels are different for differential HS mode and single-ended LP mode. The figure below shows both the HS and LP signal levels on the left and right sides, respectively. The HS signaling levels are below the LP low-level input threshold such that LP receiver always detects low on HS signals.

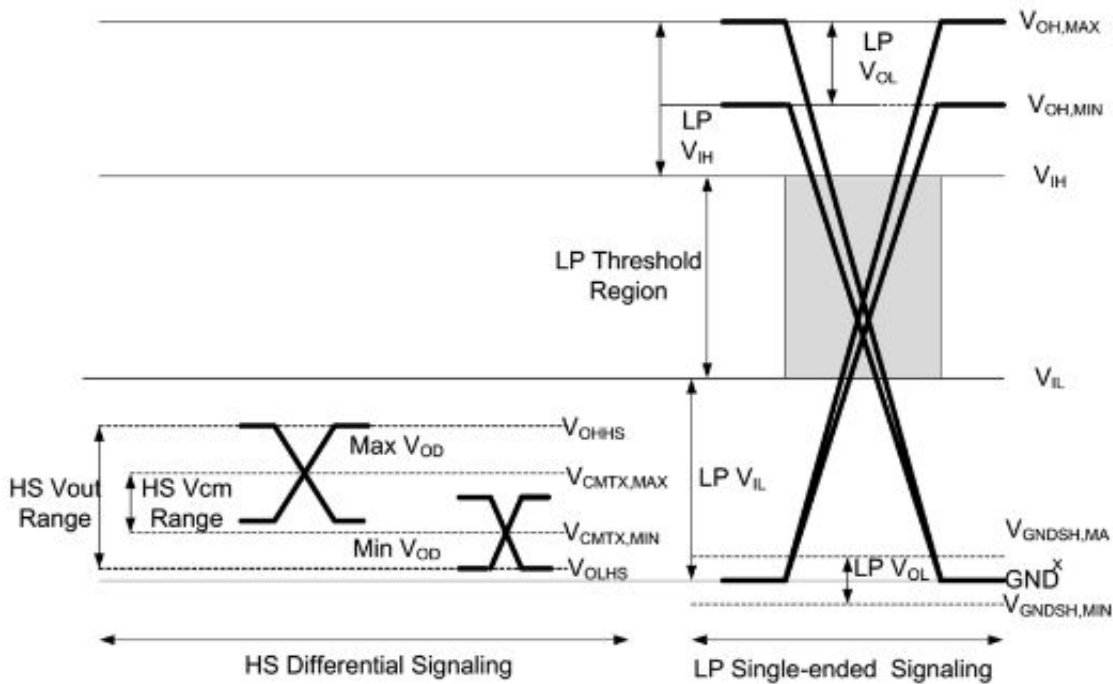

Figure 25. D-PHY signaling levels

14.1.3 D-PHY switching characteristics

Table 38. D-PHY switching characteristics

Symbol	Parameter	Conditions	Min	Typ	Max	Unit
HS Line Receiver AC Specifications						
-	Maximum serial data rate	On DATAP/N inputs. 80 Ohm $\leq R_L \leq 125\text{ Ohm}$	80	-	1000	Mbps

Table continues on the next page...

Table 38. D-PHY switching characteristics (continued)

Symbol	Parameter	Conditions	Min	Typ	Max	Unit
$\Delta V_{CMRX}(HF)$	Common mode interference beyond 450 MHz		-	-	100	mVpp
$\Delta V_{CMRX}(LF)$	Common mode interference between 50 MHz and 450 MHz		-50	-	50	mVpp
CCM	Common mode termination		-	-	60	pF
LP Line Receiver AC Specification						
e_{SPIKE}	Input pulse rejection		-	-	300	Vps
T_{MIN}	Minimum pulse response		20	-	-	ns
V_{INT}	Pk-to-Pk interference voltage		-	-	200	mV
f_{INT}	Interference frequency		450	-	-	MHz

14.1.4 Low-power receiver timing

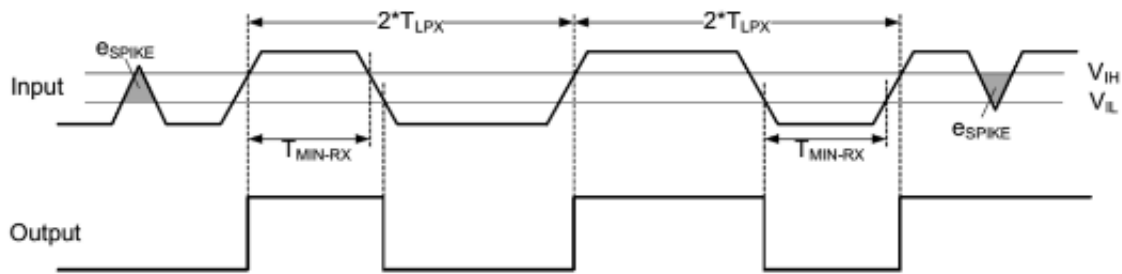

Figure 26. Input Glitch Rejection of Low-Power Receivers

14.1.5 Data to clock timing

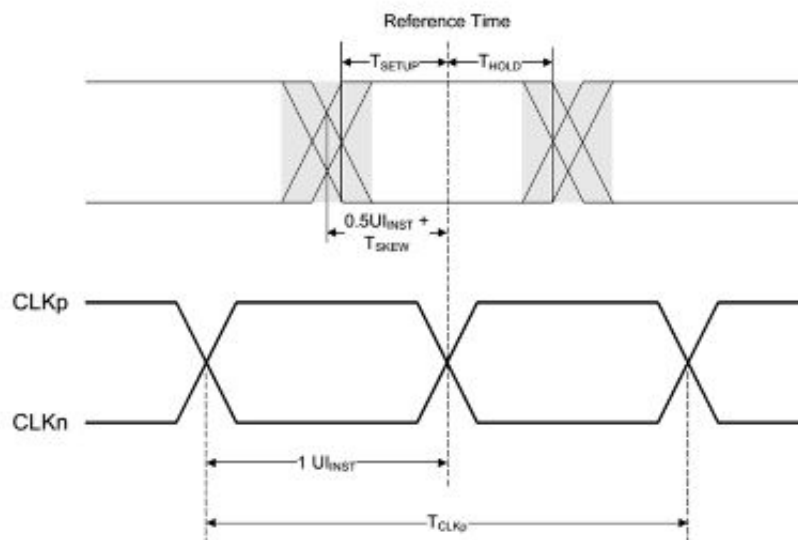

Figure 27. Definition

Table 39. Data to clock timing specifications

Symbol	Parameter	Min	Typ	Max	Unit
T_{CLKP}	Clock Period	40	-	500	MHz
U_{INST}	UI Instantaneous	1	-	12.5	ns
T_{SETUP}	Data to Clock Setup Time	0.15	-	-	U_{INST}
T_{HOLD}	Clock to Data Hold Time	0.15	-	-	U_{INST}

14.2 MIPICSI2 disclaimer

The material contained herein is not a license, either expressly or impliedly, to any IPR owned or controlled by any of the authors or developers of this material or MIPI®. The material contained herein is provided on an “AS IS” basis and to the maximum extent permitted by applicable law, this material is provided AS IS AND WITH ALL FAULTS, and the authors and developers of this material and MIPI hereby disclaim all other warranties and conditions, either express, implied or statutory, including, but not limited to, any (if any) implied warranties, duties or conditions of merchantability, of fitness for a particular purpose, of accuracy or completeness of responses, of results, of workmanlike effort, of lack of viruses, and of lack of negligence.

All materials contained herein are protected by copyright laws, and may not be reproduced, republished, distributed, transmitted, displayed, broadcast or otherwise exploited in any manner without the express prior written permission of MIPI Alliance. MIPI, MIPI Alliance and the dotted rainbow arch and all related trademarks, trade names, and other intellectual property are the exclusive property of MIPI Alliance and cannot be used without its express prior written permission.

ALSO, THERE IS NO WARRANTY OF CONDITION OF TITLE, QUIET ENJOYMENT, QUIET POSSESSION, CORRESPONDENCE TO DESCRIPTION OR NON-INFRINGEMENT WITH REGARD TO THIS MATERIAL OR THE CONTENTS OF THIS DOCUMENT. IN NO EVENT WILL ANY AUTHOR OR DEVELOPER OF THIS MATERIAL OR THE CONTENTS OF THIS DOCUMENT OR MIPI BE LIABLE TO ANY OTHER PARTY FOR THE COST OF PROCURING SUBSTITUTE GOODS OR SERVICES, LOST PROFITS, LOSS OF USE, LOSS OF DATA, OR ANY INCIDENTAL, CONSEQUENTIAL, DIRECT, INDIRECT, OR SPECIAL DAMAGES WHETHER UNDER CONTRACT, TORT, WARRANTY, OR OTHERWISE, ARISING IN ANY WAY OUT OF THIS OR ANY OTHER AGREEMENT, SPECIFICATION OR DOCUMENT RELATING TO THIS MATERIAL, WHETHER OR NOT SUCH PARTY HAD ADVANCE NOTICE OF THE POSSIBILITY OF SUCH DAMAGES.

Without limiting the generality of this Disclaimer stated above, the user of the contents of this Document is further notified that MIPI: (a) does not evaluate, test or verify the accuracy, soundness or credibility of the contents of this Document; (b) does not monitor or enforce compliance with the contents of this Document; and (c) does not certify, test, or in any manner investigate products or services or any claims of compliance with the contents of this Document. The use or implementation of the contents of this Document may involve or require the use of intellectual property rights ("IPR") including (but not limited to) patents, patent applications, or copyrights owned by one or more parties, whether or not Members of MIPI. MIPI does not make any search or investigation for IPR, nor does MIPI require or request the disclosure of any IPR or claims of IPR as respects the contents of this Document or otherwise.

15 Thermal characteristics

Table 40. 257MAPBGA package thermal characteristics

Symbol	Parameter	Conditions	257MAPBGA	Unit
R _{θJA}	Thermal resistance, junction-to-ambient natural convection ¹	Single layer board - 1s	45.4	°C/W
		Four layer board - 2s2p	27.07	
R _{θJMA}	Thermal resistance, junction-to-ambient forced convection at 200 ft/min ¹	Single layer board - 1s ²	35.67	°C/W

Table continues on the next page...

Table 40. 257MAPBGA package thermal characteristics (continued)

Symbol	Parameter	Conditions	257MAPBGA	Unit
		Four layer board - 2s2p ³	22.7	
R _{θJB}	Thermal resistance junction-to-board ⁴	—	13.01	°C/W
R _{θJC}	Thermal resistance junction-to-case ⁵	—	7.95	°C/W
Ψ _{JT}	Junction-to-package-top natural convection ⁶	Natural Convection	0.2	°C/W

- Junction temperature is a function of die size, on-chip power dissipation, package thermal resistance, mounting site (board) temperature, ambient temperature, air flow, power dissipation of other components on the board, and board thermal resistance.
- Per SEMI G38-87 and JEDEC JESD51-2 with the single layer board horizontal.
- Per JEDEC JESD51-6 with the board horizontal
- Junction-to-Board thermal resistance determined per JEDEC JESD51-8. Thermal test board meets JEDEC specification for the specified package. Board temperature is measured on the top surface of the board near the package.
- Junction-to-Case at the top of the package determined using MIL-SPEC 883 Method 1012.1. The cold plate temperature is used for the case temperature. Reported value includes the thermal resistance of the interface layer.
- Thermal characterization parameter indicating the temperature difference between the package top and the junction temperature per JEDEC JESD51-2.

Table 41. 141MAPBGA package thermal characteristics

Symbol	Parameter	Conditions	141MAPBGA	Unit
R _{θJA}	Thermal resistance, junction-to-ambient natural convection ¹	Single layer board - 1s	66.6	°C/W
		Four layer board - 2s2p	34.4	
R _{θJMA}	Thermal resistance, junction-to-ambient forced convection at 200 ft/min ¹	Single layer board - 1s ²	50.6	°C/W
		Four layer board - 2s2p ³	29.2	
R _{θJB}	Thermal resistance junction-to-board ⁴	—	13.4	°C/W
R _{θJC}	Thermal resistance junction-to-case ⁵	—	9.8	°C/W
Ψ _{JT}	Junction-to-package-top natural convection ⁶	Natural Convection	0.2	°C/W

- Junction temperature is a function of die size, on-chip power dissipation, package thermal resistance, mounting site (board) temperature, ambient temperature, air flow, power dissipation of other components on the board, and board thermal resistance.
- Per SEMI G38-87 and JEDEC JESD51-2 with the single layer board horizontal.
- Per JEDEC JESD51-6 with the board horizontal
- Junction-to-Board thermal resistance determined per JEDEC JESD51-8. Thermal test board meets JEDEC specification for the specified package. Board temperature is measured on the top surface of the board near the package.
- Junction-to-Case at the top of the package determined using MIL-SPEC 883 Method 1012.1. The cold plate temperature is used for the case temperature. Reported value includes the thermal resistance of the interface layer.
- Thermal characterization parameter indicating the temperature difference between the package top and the junction temperature per JEDEC JESD51-2.

15.1 General notes for specifications at maximum junction temperature

An estimation of the chip junction temperature, T_J, can be obtained from this equation:

$$T_J = T_A + (R_{\theta JA} \times P_D)$$

$$T_J = T_{BRD} + (R_{\theta JB} \times P_D)$$

where:

- T_A = ambient temperature for the package ($^{\circ}\text{C}$)
- $R_{\theta JA}$ = junction to ambient thermal resistance ($^{\circ}\text{C}/\text{W}$)
- $R_{\theta JB}$ = junction to board thermal resistance ($^{\circ}\text{C}/\text{W}$)
- $T_{\theta BRD}$ = average board temperature just outside the package periphery ($^{\circ}\text{C}$)
- P_D = power dissipation in the package (W)

The junction to ambient thermal resistance is an industry standard parameter that provides a quick and easy estimation of thermal performance. However, junction to board thermal resistance is more appropriate for tight enclosure spaces where board temperature should be used as reference temperature. Using 2s2p board with natural convection conditions, junction temperature is found to be less than 150°C . There are two parameters in common usage: the value determined on a single layer board and the value obtained on a board with two inner planes. For packages such as PBGA, these values can significantly differ. For customer board design with different number of layers and copper percentage content, these values must be appropriately interpolated in order to evaluate junction temperature. In general, the value obtained on a single layer board is appropriate for the tightly packed printed circuit board. The value obtained on the board with the internal planes is usually appropriate if the board has low power dissipation and the components are well separated.

When a heat sink is used, the thermal resistance is expressed in the following equation as the sum of a junction-to-case thermal resistance and a case-to-ambient thermal resistance:

$$R_{\theta JA} = R_{\theta JC} + R_{\theta CA}$$

where:

- $R_{\theta JA}$ = junction to ambient thermal resistance ($^{\circ}\text{C}/\text{W}$)
- $R_{\theta JC}$ = junction to case thermal resistance ($^{\circ}\text{C}/\text{W}$)
- $R_{\theta CA}$ = case to ambient thermal resistance ($^{\circ}\text{C}/\text{W}$)

$R_{\theta JC}$ is device related and cannot be influenced by the user. The user controls the thermal environment to change the case to ambient thermal resistance, $R_{\theta CA}$. For instance, the user can change the size of the heat sink, the air flow around the device, the interface material, the mounting arrangement on printed circuit board, or change the thermal dissipation on the printed circuit board surrounding the device.

To determine the junction temperature of the device in the application when heat sinks are not used, the Thermal Characterization Parameter (Ψ_{JT}) can be used to determine the junction temperature with a measurement of the temperature at the top center of the package case using this equation:

$$T_J = T_T + (\Psi_{JT} \times P_D)$$

where:

- T_T = thermocouple temperature on top of the package ($^{\circ}\text{C}$)
- Ψ_{JT} = thermal characterization parameter ($^{\circ}\text{C}/\text{W}$)
- P_D = power dissipation in the package (W)

The thermal characterization parameter is measured per JESD51-2 specification using a 40 gauge type T thermocouple epoxied to the top center of the package case. The thermocouple should be positioned so that the thermocouple junction rests on the package. A small amount of epoxy is placed over the thermocouple junction and over about 1 mm of wire extending from the junction. The thermocouple wire is placed flat against the package case to avoid measurement errors caused by cooling effects of the thermocouple wire.

15.2 References

Semiconductor Equipment and Materials International; 3081 Zanker Road; San Jose, CA 95134 USA; (408) 943-6900

MIL-SPEC and EIA/JESD (JEDEC) specifications are available from Global Engineering Documents at 800-854-7179 or 303-397-7956.

JEDEC specifications are available on the Web at <http://www.jedec.org>.

1. C.E. Triplett and B. Joiner, "An Experimental Characterization of a 272 PBGA Within an Automotive Engine Controller Module," Proceedings of SemiTherm, San Diego, 1998, pp. 47–54.
2. G. Kromann, S. Shidore, and S. Addison, "Thermal Modeling of a PBGA for Air-Cooled Applications," Electronic Packaging and Production, pp. 53–58, March 1998.
3. B. Joiner and V. Adams, "Measurement and Simulation of Junction to Board Thermal Resistance and Its Application in Thermal Modeling," Proceedings of SemiTherm, San Diego, 1999, pp. 212–220.

16 Packaging

The S32R372 is offered in the following package types.

If you want the drawing for this package	Then use this document number
257-ball MAPBGA	98ASA00081D
141-ball MAPBGA	98ASA01014D

NOTE

For detailed information regarding package drawings, refer to www.nxp.com.

17 Reset sequence

This section describes different reset sequences and details the duration for which the device remains in reset condition in each of those conditions.

17.1 Reset sequence duration

[Table 43](#) specifies the minimum and the maximum reset sequence duration for the five different reset sequences described in [Reset sequence description](#).

Table 43. RESET sequences

No.	Symbol	Parameter	T _{Reset}			Unit
			Min	Typ	Max ¹	
1	T _{DRB}	Destructive Reset Sequence, BIST enabled	15		50 ²	ms
2	T _{DR}	Destructive Reset Sequence, BIST disabled	400		2000	μs
3	T _{ERLB}	External Reset Sequence Long, BIST enabled	15		50	ms
4	T _{FRL}	Functional Reset Sequence Long, BIST disabled	400		2000	μs
5	T _{FRS}	Functional Reset Sequence Short ³	1		500	μs

1. The maximum value is applicable only if the reset sequence duration is not prolonged by an extended assertion of $\overline{\text{RESET}}$ by an external reset generator.
2. Max time is based on STCU BIST configuration execution time + max RESET time (TDR). For default STCU BIST configuration execution time.
3. BIST is not executed on short functional reset

17.2 Reset sequence description

The figures in this section show the internal states of the device during the five different reset sequences. The dotted lines in the figures indicate the starting point and the end point for which the duration is specified in [Table 43](#).

With the beginning of DRUN mode, the first instruction is fetched and executed. At this point, application execution starts and the internal reset sequence is finished.

The SMPS self test is always triggered during Phase3 after a destructive reset so that duration is included into Phase3 below.

In external regulation mode, the VREG_POR_B pin should be de-asserted only when all the design supplies are in operating range. Deassertion of VREG_POR_B pin triggers the start of reset sequence in internal as well as external regulation modes.

The following figures show the internal states of the device during the execution of the reset sequence and the possible states of the RESET_B signal pin.

NOTE

RESET_B is a bidirectional pin. The voltage level on this pin can either be driven low by an external reset generator or by the device internal reset circuitry. A high level on this pin can only be generated by an external pullup resistor which is strong enough to overdrive the weak internal pulldown resistor. The rising edge on RESET_B in the following figures indicates the time when the device stops driving it low. The reset sequence durations given in [Table 43](#) are applicable only if the internal reset sequence is not prolonged by an external reset generator keeping RESET_B asserted low beyond the last Phase3.

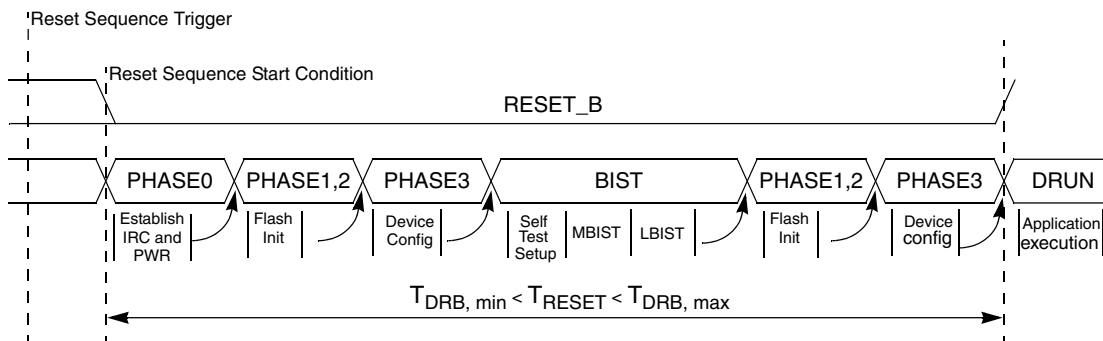

Figure 28. Destructive reset sequence, BIST enabled

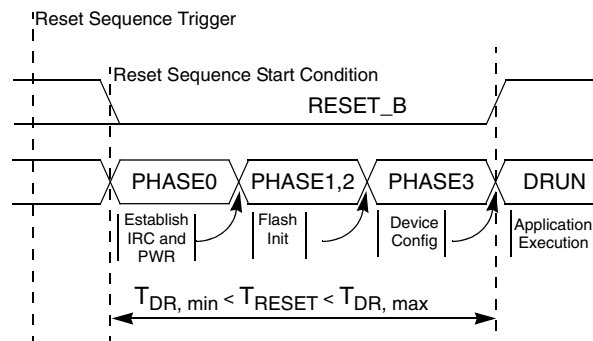

Figure 29. Destructive reset sequence, BIST disabled

Reset sequence

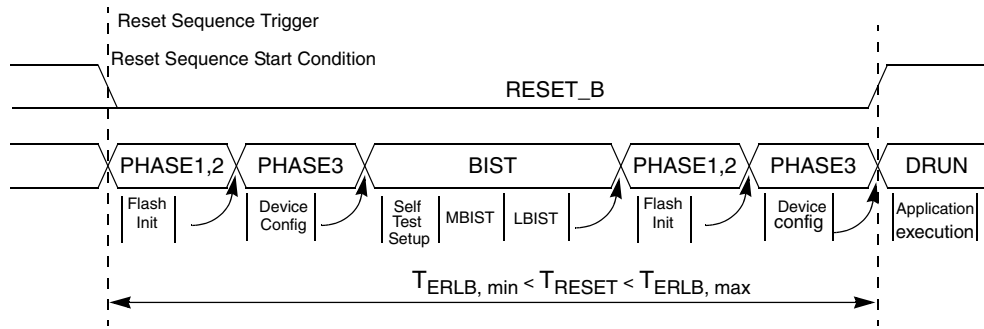

Figure 30. External reset sequence long, BIST enabled

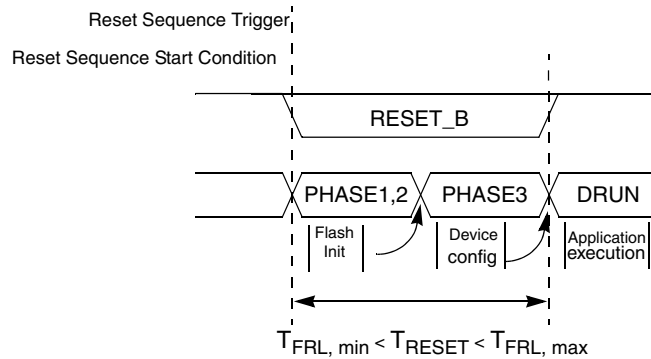

Figure 31. Functional reset sequence long

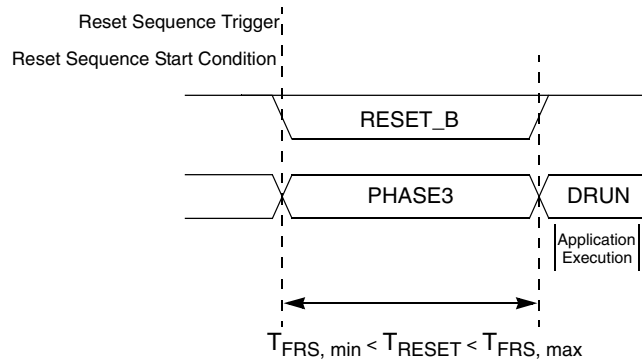

Figure 32. Functional reset sequence short

The reset sequences shown in [Figure 31](#) and [Figure 32](#) are triggered by functional reset events. $\overline{\text{RESET}}$ is driven low during these two reset sequences only if the corresponding functional reset source (which triggered the reset sequence) was enabled to drive $\overline{\text{RESET_B}}$ low for the duration of the internal reset sequence. See the RGM_FBRE register in the device reference manual for more information.

18 Power sequencing requirements

NOTE

Following table describes the power and ground groups that **MUST** be formed while designing the application board. "DC short" on board for a group of package pins mean that they should be powered through the same DC source, with appropriate passive filtering to ensure that required AC noise isolation is in place, but their DC supply levels remains the same for all practical purposes.

Table 44. Power and ground grouping

BGA257 package connection	BGA257 Board Connection	BGA141 package connection	BGA141 Board Connection
V_{DD}	DC short: V_{DD_LV}	V_{DD_LV}	DC short: V_{DD_LV}
$V_{DD_LV_IO_AURORA}$		$V_{DD_LV_IO_AURORA}$	
$V_{DD_LV_PLL0}$		$V_{DD_LV_PLL0}$	
$V_{DD_LV_LFAST_PLL}$			
$V_{DD_LV_DPHY}^1$		$V_{DD_LV_DPHY}^1$	
$V_{DD_HV_IO}$	DC short: $V_{DD_HV_DIG}$	$V_{DD_HV_IO}$	DC short: $V_{DD_HV_DIG}$
$V_{DD_HV_IO_PWM}$			
$V_{DD_HV_IO}$			
$V_{DD_HV_FLA}$		$V_{DD_HV_FLA}$	
$V_{DD_HV_PMU}$		$V_{DD_HV_PMU}$	
$V_{DD_HV_REG3V8}$	$V_{DD_HV_REG3V8}$		
$V_{DD_HV_ADCREFP1}$	$V_{DD_HV_ADCREFP1}$	$V_{DD_HV_ADCREFP}$	$V_{DD_HV_ADCREFP}$
$V_{DD_HV_ADCREFP0}$	$V_{DD_HV_ADCREFP0}$		
$V_{DD_HV_ADC}$	$V_{DD_HV_ADC}$	$V_{DD_HV_ADC}$	$V_{DD_HV_ADC}$
$V_{DD_HV_RAW}$	$V_{DD_HV_RAW}$	$V_{DD_HV_RAW}$	$V_{DD_HV_RAW}$
$V_{DD_HV_DAC}$			
$V_{DD_LV_RADARREF}$	$V_{DD_LV_RADARREF}$	$V_{DD_LV_RADARREF}$	$V_{DD_LV_RADARREF}$
$V_{DD_LV_SDPLL}$	$V_{DD_LV_SDPLL}$	$V_{DD_LV_SDPLL}$	$V_{DD_LV_SDPLL}$
$V_{DD_LV_OSC}$	$V_{DD_LV_OSC}$	$V_{DD_LV_OSC}$	$V_{DD_LV_OSC}$
$V_{DD_LV_SDCLK}$	$V_{DD_LV_SDCLK}$	$V_{DD_LV_SDCLK}$	$V_{DD_LV_SDCLK}$
$V_{SS_LV_COR}$	DC short: V_{SS}	$V_{SS_LV_COR}$	DC short: V_{SS}
$V_{SS_LV_PLL0}$		$V_{SS_LV_IO_AURORA}$	
$V_{SS_LV_LFAST_PLL}$			
$V_{SS_LV_PHY}$			
$V_{SS_LV_IO_AURORA}$			
$V_{SS_HV_IO}$			
		$V_{SS_LV_COR}$	

Table continues on the next page...

Table 44. Power and ground grouping (continued)

BGA257 package connection	BGA257 Board Connection	BGA141 package connection	BGA141 Board Connection
V _{SS_HV_IO_PWM}			
V _{SS_LV_COR}			
V _{SS_HV_REG3V8}	V _{SS_HV_REG3V8}		
V _{SS_LV_COR}	DC short: V _{SS}		
V _{SS_SUB_OUTPWB}	DC short: V _{SS}		
V _{SS_HV_ADCREF1}	V _{SS_HV_ADCREF1}	V _{SS_HV_ADCREF}	V _{SS_HV_ADCREF}
V _{SS_HV_ADCREF0}	V _{SS_HV_ADCREF0}		
V _{SS_HV_ADC}	DC short: V _{SS_HV_ANA}	V _{SS_HV_ADC}	DC short: V _{SS_HV_ANA}
V _{SS_HV_RAW}		V _{SS_AFE}	
V _{SS_HV_DAC}			
V _{SS_LV_RADARREF}			
V _{SS_LV_SDPLL}			
V _{SS_LV_OSC}			
V _{SS_LV_SDCLK}			
V _{SS_SUB_INPWB0}			
V _{SS_SUB_INPWB1}			

1. Refer to AN5251. Contact your NXP sales representative for details.

The device does not require any specific power sequencing as far as user follows recommendations in this section.

As mentioned in the previous section, it is expected that the external ASIC which powers up the device in external regulation mode deasserts VREG_POR_B pin only when all the power supplies to the design are in operating range.

It should be noted that LVD and HVD detectors on VDD supply are disabled by default in external regulation mode for preventing a conflict with external regulator operation but they can be enabled by software once design is powered up.

While designing the system, it is important to ensure that AFE supplies are powered up before data is sent on its input pads or the crystal oscillator pins EXTAL / XTAL are driven by an external clock source.

19 Package pinouts and signal descriptions

For package pinouts and signal descriptions, see the S32R372 Reference Manual.

20 Release Notes

Table 45. Release notes

Revision	Date	Description
1	28 Nov 2016	Initial release
2	15 Sep 2017	<ul style="list-style-type: none"> In Table 22 added rows for the symbols t_{sampleC}, t_{sampleS}, t_{sampleBG}, and t_{sampleTS}. In Table 6 changed the Max voltage of LVDS external clock input voltage parameter from 1.23 V to 1.36 V. In Nexus Aurora debug port timing, added spec for EVTI Pulse Width. In Table 6, updated $V_{\text{inXoscclkvih}}$ from 1.2V to 1.23V. In Table 17, updated t_{jitcc} from 3.5ps to 2.5ps.
3	14 May 2018	<ul style="list-style-type: none"> In Table 5 : <ul style="list-style-type: none"> Changed Maximum value for V_{INA} from $V_{\text{DD_HV_ADCREFX}} + 0.3$ to 6.0. Added footnote to I_{INJPAD} to state "The maximum value limits of injection current and input voltage both must be followed together for proper device operation." In Table 6, changed V_{INA} Maximum value from $V_{\text{DD_HV_ADCREFX}} + 0.3$ to $V_{\text{DD_HV_ADCREFX}}$.
3.1	09 July 2018	<ul style="list-style-type: none"> In Table 5, removed footnote on I_{INJPAD}.
4	14 Aug 2018	<ul style="list-style-type: none"> On the first page, changed document classification from 'Advance Information' to 'Technical Data'.

How to Reach Us:**Home Page:**nxp.com**Web Support:**nxp.com/support

Information in this document is provided solely to enable system and software implementers to use NXP products. There are no express or implied copyright licenses granted hereunder to design or fabricate any integrated circuits based on the information in this document. NXP reserves the right to make changes without further notice to any products herein.

NXP makes no warranty, representation, or guarantee regarding the suitability of its products for any particular purpose, nor does NXP assume any liability arising out of the application or use of any product or circuit, and specifically disclaims any and all liability, including without limitation consequential or incidental damages. "Typical" parameters that may be provided in NXP data sheets and/or specifications can and do vary in different applications, and actual performance may vary over time. All operating parameters, including "typicals," must be validated for each customer application by customer's technical experts. NXP does not convey any license under its patent rights nor the rights of others. NXP sells products pursuant to standard terms and conditions of sale, which can be found at the following address: nxp.com/SalesTermsandConditions.

While NXP has implemented advanced security features, all products may be subject to unidentified vulnerabilities. Customers are responsible for the design and operation of their applications and products to reduce the effect of these vulnerabilities on customer's applications and products, and NXP accepts no liability for any vulnerability that is discovered. Customers should implement appropriate design and operating safeguards to minimize the risks associated with their applications and products.

NXP, the NXP logo, NXP SECURE CONNECTIONS FOR A SMARTER WORLD, COOLFLUX, EMBRACE, GREENCHIP, HITAG, I2C BUS, ICODE, JCOP, LIFE VIBES, MIFARE, MIFARE CLASSIC, MIFARE DESFire, MIFARE PLUS, MIFARE FLEX, MANTIS, MIFARE ULTRALIGHT, MIFARE4MOBILE, MIGLO, NTAG, ROADLINK, SMARTLX, SMARTMX, STARPLUG, TOPFET, TRENCHMOS, UCODE, Freescale, the Freescale logo, AltiVec, C-5, CodeTEST, CodeWarrior, ColdFire, ColdFire+, C-Ware, the Energy Efficient Solutions logo, Kinetis, Layerscape, MagniV, mobileGT, PEG, PowerQUICC, Processor Expert, QorIQ, QorIQ Qonverge, Ready Play, SafeAssure, the SafeAssure logo, StarCore, Symphony, VortiQa, Vybrid, Airfast, BeeKit, BeeStack, CoreNet, Flexis, MXC, Platform in a Package, QUICC Engine, SMARTMOS, Tower, TurboLink, and UMEMS are trademarks of NXP B.V. All other product or service names are the property of their respective owners. AMBA, Arm, Arm7, Arm7TDMI, Arm9, Arm11, Artisan, big.LITTLE, Cordio, CoreLink, CoreSight, Cortex, DesignStart, DynamIQ, Jazelle, Keil, Mali, Mbed, Mbed Enabled, NEON, POP, RealView, SecurCore, Socrates, Thumb, TrustZone, ULINK, ULINK2, ULINK-ME, ULINK-PLUS, ULINKpro, μ Vision, Versatile are trademarks or registered trademarks of Arm Limited (or its subsidiaries) in the US and/or elsewhere. The related technology may be protected by any or all of patents, copyrights, designs and trade secrets. All rights reserved. Oracle and Java are registered trademarks of Oracle and/or its affiliates. The Power Architecture and Power.org word marks and the Power and Power.org logos and related marks are trademarks and service marks licensed by Power.org.

© 2017 NXP B.V.

Document Number S32R372
Revision 4, 08/2018



Компания «Life Electronics» занимается поставками электронных компонентов импортного и отечественного производства от производителей и со складов крупных дистрибьюторов Европы, Америки и Азии.

С конца 2013 года компания активно расширяет линейку поставок компонентов по направлению коаксиальный кабель, кварцевые генераторы и конденсаторы (керамические, пленочные, электролитические), за счёт заключения дистрибьюторских договоров

Мы предлагаем:

- Конкурентоспособные цены и скидки постоянным клиентам.
- Специальные условия для постоянных клиентов.
- Подбор аналогов.
- Поставку компонентов в любых объемах, удовлетворяющих вашим потребностям.
- Приемлемые сроки поставки, возможна ускоренная поставка.
- Доставку товара в любую точку России и стран СНГ.
- Комплексную поставку.
- Работу по проектам и поставку образцов.
- Формирование склада под заказчика.
- Сертификаты соответствия на поставляемую продукцию (по желанию клиента).
- Тестирование поставляемой продукции.
- Поставку компонентов, требующих военную и космическую приемку.
- Входной контроль качества.
- Наличие сертификата ISO.

В составе нашей компании организован Конструкторский отдел, призванный помогать разработчикам, и инженерам.

Конструкторский отдел помогает осуществить:

- Регистрацию проекта у производителя компонентов.
- Техническую поддержку проекта.
- Защиту от снятия компонента с производства.
- Оценку стоимости проекта по компонентам.
- Изготовление тестовой платы монтаж и пусконаладочные работы.



Тел: +7 (812) 336 43 04 (многоканальный)

Email: org@lifeelectronics.ru