

LOW POWER LOW OFFSET VOLTAGE QUAD COMPARATORS**AS339/339A****General Description**

The AS339/339A consist of four independent precision voltage comparators with a typical offset voltage of 2.0mV and high gain. They are specifically designed to operate from a single power supply over wide range of voltages. Operation from split power supply is also possible and the low power supply current drain is independent of the magnitude of the power supply voltage.

The AS339/339A series are compatible with industry standard 339. AS339A has more stringent input offset voltage than AS339.

The AS339 is available in DIP-14, SOIC-14 and TSSOP-14 packages, AS339A is available in SOIC-14 package.

Features

- Wide Supply Voltage Range
 - Single Supply: 2.0V to 36V
 - Dual Supplies: $\pm 1.0V$ to $\pm 18V$
- Low Supply Current Drain: 0.9mA
- Low Input Bias Current: 25nA (Typical)
- Low Input Offset Current: $\pm 5.0nA$ (Typical)
- Low Input Offset Voltage: 2.0mV (Typical)
- Input Common Mode Voltage Range Includes Ground
- Differential Input Voltage Range Equals to the Power Supply Voltage
- Low Output Saturation Voltage: 200mV at 4mA
- Open Collector Output

Applications

- Battery Charger
- Cordless Telephone
- Switching Power Supply
- DC-DC Module
- PC Motherboard
- Communication Equipment



Figure 1. Package Types of AS339/339A



LOW POWER LOW OFFSET VOLTAGE QUAD COMPARATORS AS339/339A

Pin Configuration

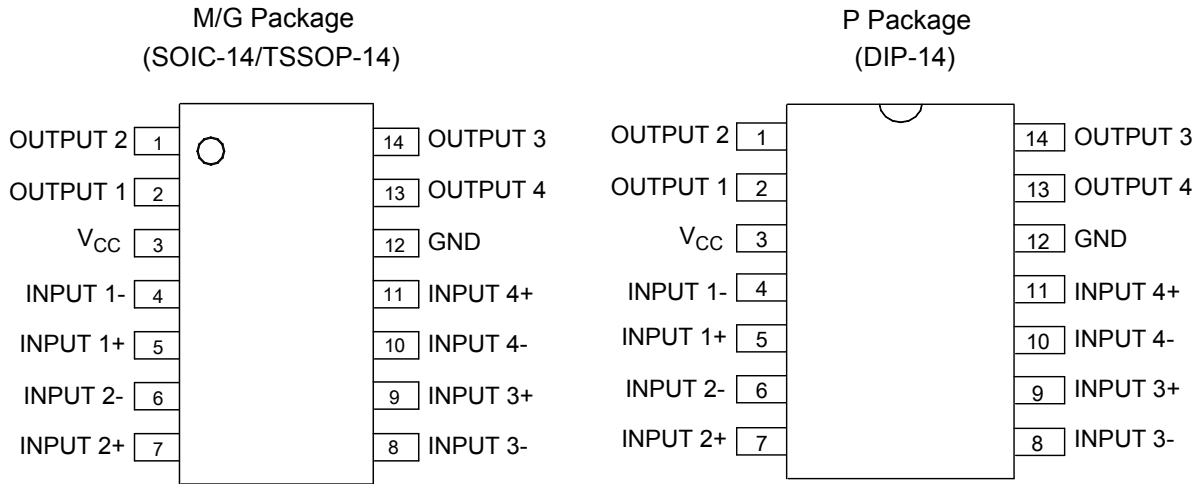

Figure 2. Pin Configuration of AS339/339A (Top View)

Functional Block Diagram

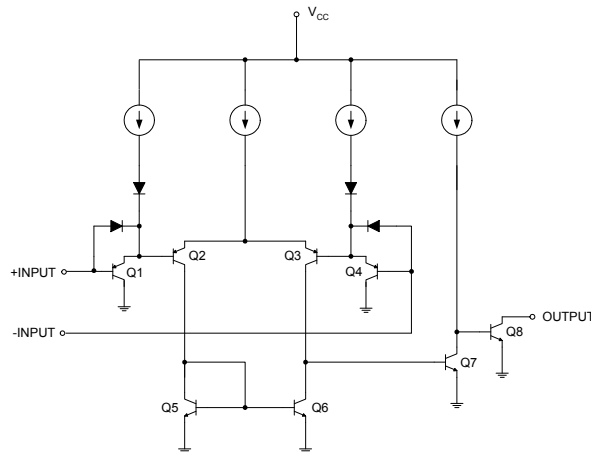
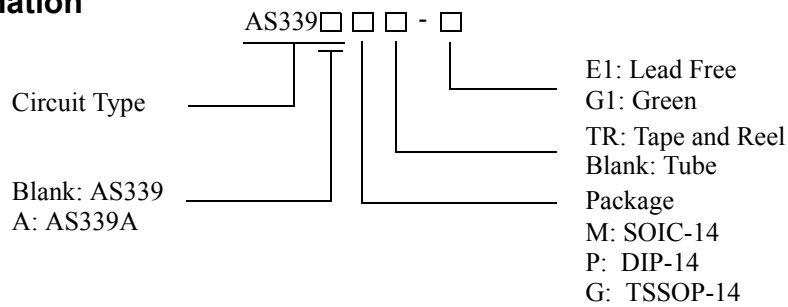

Figure 3. Functional Block Diagram of AS339/339A (Each comparator)

Ordering Information





LOW POWER LOW OFFSET VOLTAGE QUAD COMPARATORS AS339/339A

Ordering Information (Continued)

Package	Temperature Range	Part Number		Marking ID		Packing Type
		Lead Free	Green	Lead Free	Green	
SOIC-14	-40 to 85°C	AS339M-E1	AS339M-G1	AS339M-E1	AS339M-G1	Tube
		AS339MTR-E1	AS339MTR-G1	AS339M-E1	AS339M-G1	Tape & Reel
		AS339AM-E1	AS339AM-G1	AS339AM-E1	AS339AM-G1	Tube
		AS339AMTR-E1	AS339AMTR-G1	AS339AM-E1	AS339AM-G1	Tape & Reel
DIP-14		AS339P-E1	AS339P-G1	AS339P-E1	AS339P-G1	Tube
TSSOP-14		AS339GTR-E1	AS339GTR-G1	EGS339	GG339	Tape & Reel

BCD Semiconductor's Pb-free products, as designated with "E1" suffix in the part number, are RoHS compliant. Products with "G1" suffix are available in green packages.

Absolute Maximum Ratings (Note 1)

Parameter	Symbol	Value	Unit
Supply Voltage	V _{CC}	40	V
Differential Input Voltage	V _{ID}	40	V
Input Voltage	V _{IN}	-0.3 to 40	V
Input Current (V _{IN} <-0.3V) (Note 2)	I _{IN}	50	mA
Output Short-Circuit to Ground		Continuous	
Power Dissipation (T _A =25°C)	P _D	DIP-14	1050
		SOIC-14	890
		TSSOP-14	790
Operating Junction Temperature	T _J	150	°C
Storage Temperature Range	T _{STG}	-65 to 150	°C
Lead Temperature (Soldering, 10 Seconds)	T _{LEAD}	260	°C

Note 1: Stresses greater than those listed under "Absolute Maximum Ratings" may cause permanent damage to the device. These are stress ratings only, and functional operation of the device at these or any other conditions beyond those indicated under "Recommended Operating Conditions" is not implied. Exposure to "Absolute Maximum Ratings" for extended periods may affect device reliability.

Note 2: This input current will only exist when the voltage at any of the input leads is driven negative. It is due to the collector-base junction of the input PNP transistors becoming forward biased and thereby acting as input diode clamps. In addition to this diode action, there is also lateral NPN parasitic transistor action on the IC chip. This transistor action can cause the output voltages of the comparators to go to the V+ voltage level (or to ground for a large overdrive) for the time duration that an input is driven negative. This is not destructive and normal output states will re-establish when the input voltage, which was negative, again returns to a value greater than -0.3 V_{DC} (at 25°C).



LOW POWER LOW OFFSET VOLTAGE QUAD COMPARATORS AS339/339A

Recommended Operating Conditions

Parameter	Symbol	Min	Max	Unit
Supply Voltage	V_{CC}	2	36	V
Operating Temperature Range	T_A	-40	85	$^{\circ}C$

Electrical Characteristics

Limits in standard typeface are for $T_A=25^{\circ}C$, **bold** typeface applies over $T_A=-40^{\circ}C$ to $85^{\circ}C$ (Note 3), $V_{CC}=5V$, $GND=0V$, unless otherwise specified.

Parameter	Conditions	Min	Typ	Max	Unit
Input Offset Voltage	$V_O=1.4V$, $R_S=0\Omega$, V_{CC} from 5V to 30V	AS339	2	5	mV
			7		
		AS339A	2	3	
			5		
Input Bias Current	I_{IN+} or I_{IN-} with output in Linear Range, $V_{CM}=0V$		25	250	nA
				400	
Input Offset Current	$I_{IN+} - I_{IN-}$, $V_{CM}=0V$		5.0	50	nA
				200	
Input Common Mode Voltage Range (Note 4)	$V_{CC}=30V$	0		$V_{CC}-1.5$	V
Supply Current	$R_L=\infty$	$V_{CC}=5V$	0.9	2.0	mA
			3.0		
		$V_{CC}=30V$	1.2	2.5	
			3.5		
Voltage Gain	$R_L \geq 15k\Omega$, $V_{CC}=15V$, $V_O=1V$ to 11V	50	200		V/mV
Large Signal Response Time	$V_{IN}=\text{TTL Logic Swing}$, $V_{REF}=1.4V$ $V_{RL}=5V$, $R_L=5.1k\Omega$		200		ns
Response Time	$V_{RL}=5V$, $R_L=5.1k\Omega$		1.3		μs
Output Sink Current	$V_{IN-}=1V$, $V_{IN+}=0$, $V_O=1.5V$	6.0	16		mA
Output Leakage Current	$V_{IN-}=0V$, $V_{IN+}=1V$, $V_O=5V$		0.1		nA
	$V_{IN-}=0V$, $V_{IN+}=1V$, $V_O=30V$			1	μA
Saturation Voltage	$V_{IN-}=1V$, $V_{IN+}=0$, $I_{SINK} \leq 4mA$		200	400	mV
				500	
Thermal Resistance (Junction to Case)	SOIC-14		51.93		$^{\circ}C/W$
	DIP-14		35.00		

Note 3: Limits over the full temperature are guaranteed by design, but not tested in production.

Note 4: The input common-mode voltage of either input signal voltage should not be allowed to go negatively by more than 0.3V (at $25^{\circ}C$). The upper end of the common-mode voltage range is $V_{CC}-1.5V$ (at $25^{\circ}C$), but either or both inputs can go to +36V without damages, independent of the magnitude of the V_{CC} .



LOW POWER LOW OFFSET VOLTAGE QUAD COMPARATORS AS339/339A

Typical Performance Characteristics

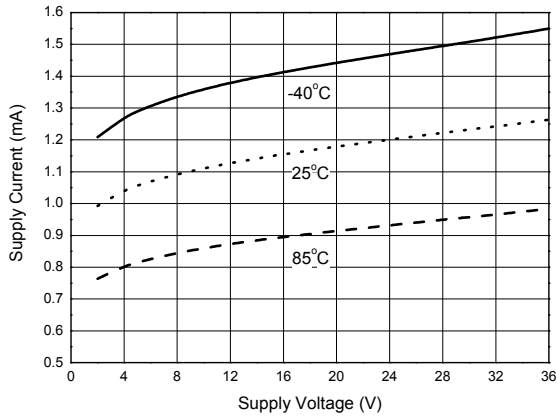

Figure 4. Supply Voltage vs. Supply Current

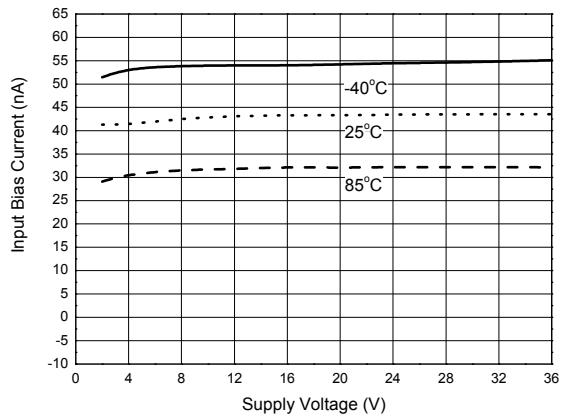

Figure 5. Supply Voltage vs. Input Bias Current

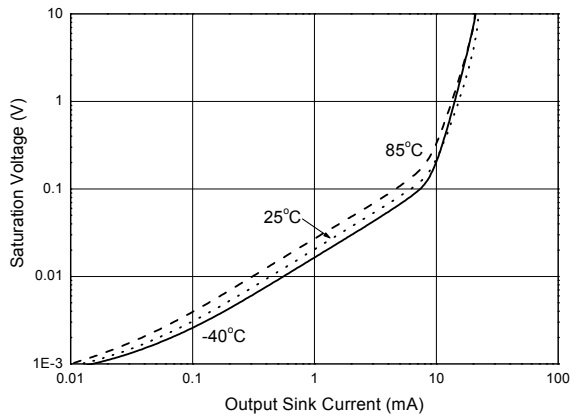

Figure 6. Output Sink Current vs. Saturation Voltage

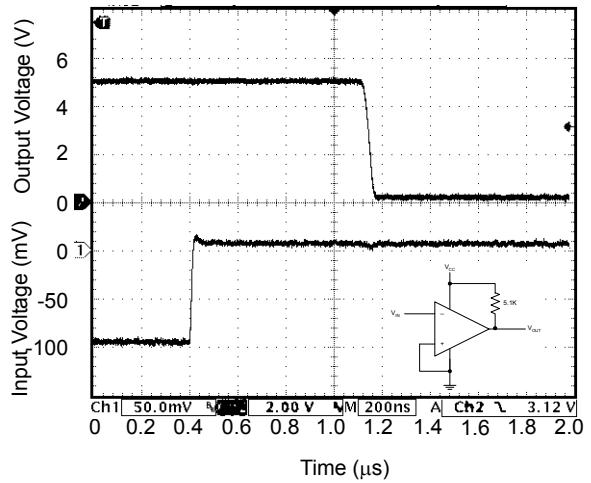

Figure 7. Response Time for 5mV Input Overdrive - Negative Transition



LOW POWER LOW OFFSET VOLTAGE QUAD COMPARATORS AS339/339A

Typical Performance Characteristics (Continued)

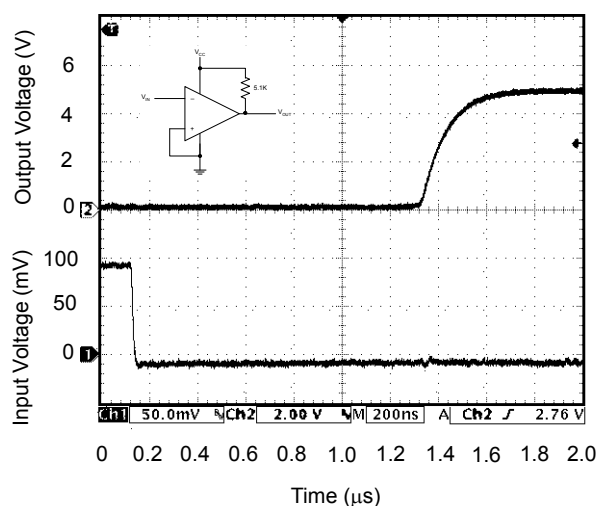

Figure 8. Response Time for 5mV Input Overdrive - Positive Transition

LOW POWER LOW OFFSET VOLTAGE QUAD COMPARATORS AS339/339A

Typical Applications

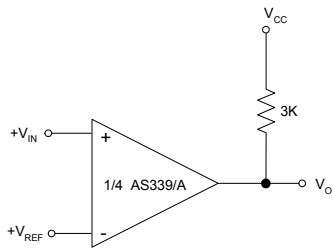

Figure 9. Basic Comparator

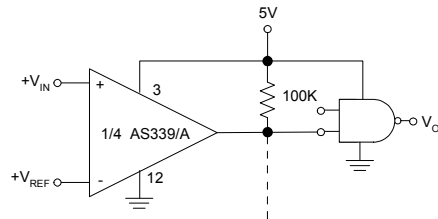

Figure 10. Driving CMOS

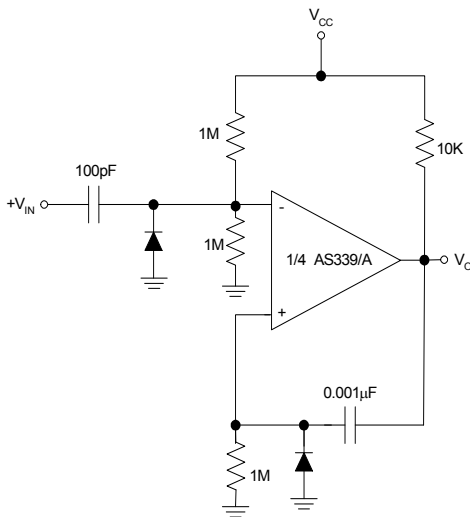

Figure 11. One Shot Multivibrator

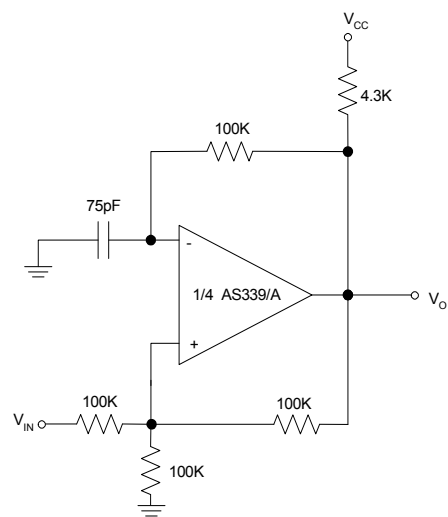

Figure 12. Squarewave Oscillator



LOW POWER LOW OFFSET VOLTAGE QUAD COMPARATORS AS339/339A

Mechanical Dimensions

DIP-14

Unit: mm(inch)

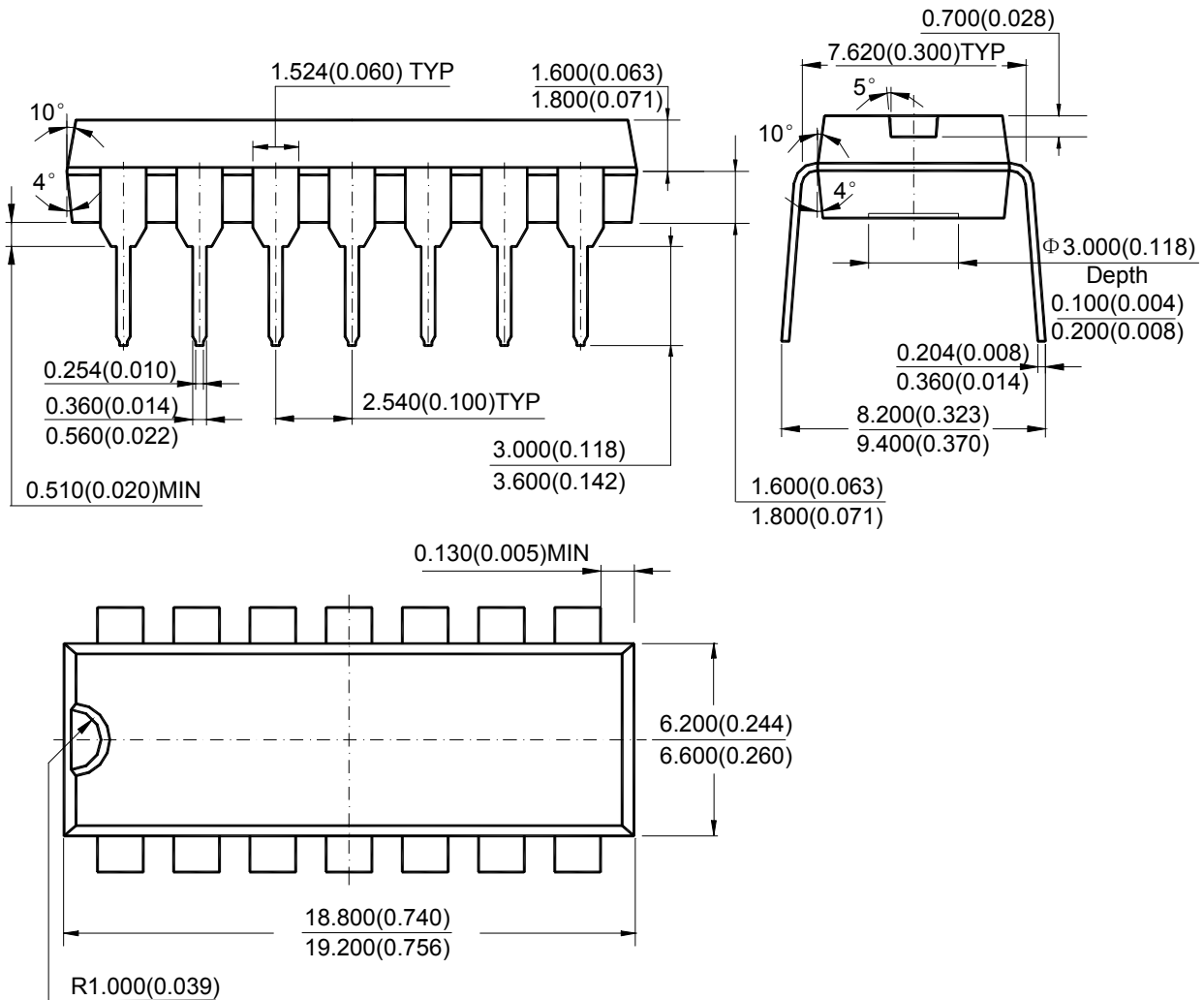

Note: Eject hole, oriented hole and mold mark is optional.



LOW POWER LOW OFFSET VOLTAGE QUAD COMPARATORS AS339/339A

Mechanical Dimensions (Continued)

SOIC-14

Unit: mm(inch)

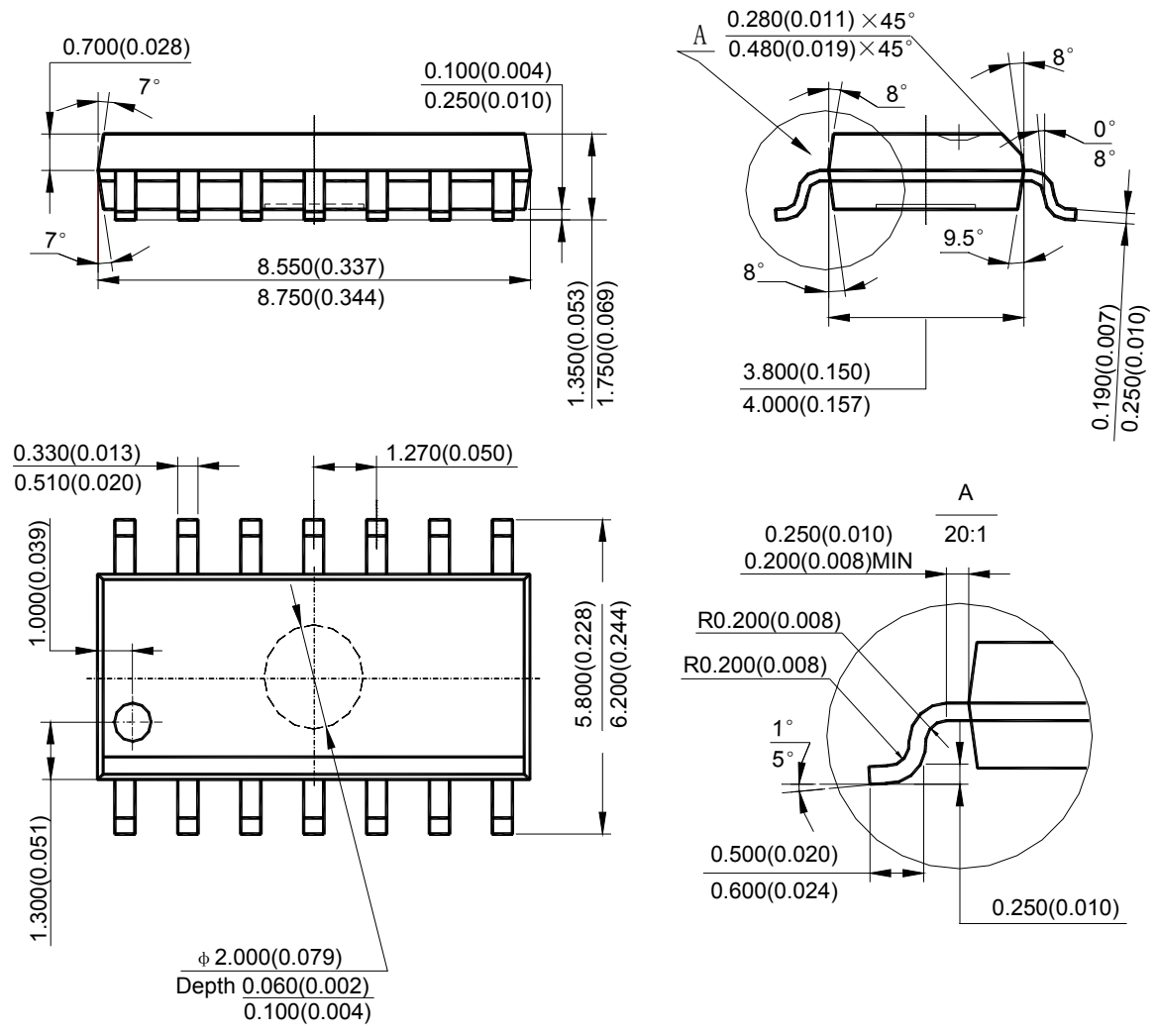

Note: Eject hole, oriented hole and mold mark is optional.



LOW POWER LOW OFFSET VOLTAGE QUAD COMPARATORS AS339/339A

Mechanical Dimensions (Continued)

TSSOP-14

Unit: mm(inch)

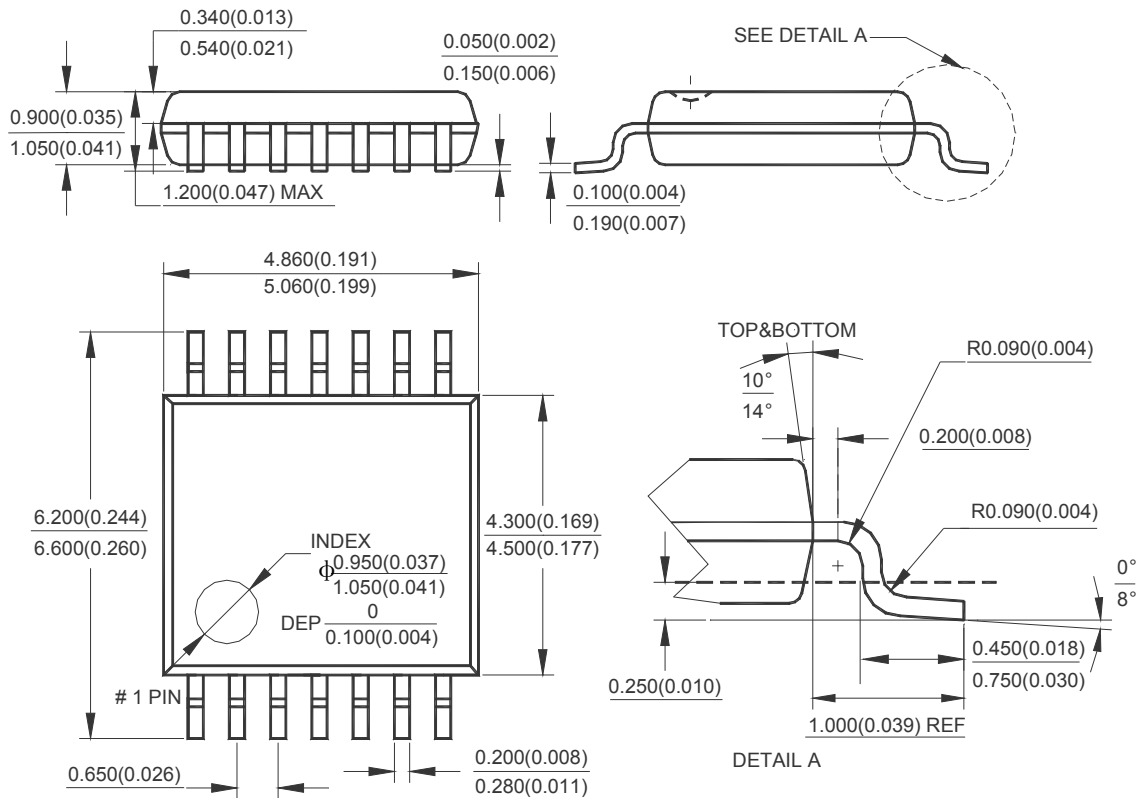

Note: Eject hole, oriented hole and mold mark is optional.



BCD Semiconductor Manufacturing Limited

<http://www.bcdsemi.com>

IMPORTANT NOTICE

BCD Semiconductor Manufacturing Limited reserves the right to make changes without further notice to any products or specifications herein. BCD Semiconductor Manufacturing Limited does not assume any responsibility for use of any its products for any particular purpose, nor does BCD Semiconductor Manufacturing Limited assume any liability arising out of the application or use of any its products or circuits. BCD Semiconductor Manufacturing Limited does not convey any license under its patent rights or other rights nor the rights of others.

MAIN SITE

- Headquarters

BCD Semiconductor Manufacturing Limited

No. 1600, Zi Xing Road, Shanghai Zizhu Science-based Industrial Park, 200241, China
Tel: +86-21-24162266, Fax: +86-21-24162277

- Wafer Fab

Shanghai SIM-BCD Semiconductor Manufacturing Co., Ltd.

800 Yi Shan Road, Shanghai 200233, China
Tel: +86-21-6485 1491, Fax: +86-21-5450 0008

REGIONAL SALES OFFICE

Shenzhen Office

Shanghai SIM-BCD Semiconductor Manufacturing Co., Ltd., Shenzhen Office

Unit A Room 1203, Skyworth Bldg., Gaoxin Ave. 1.S., Nanshan District, Shenzhen, China
Tel: +86-755-8826 7951
Fax: +86-755-8826 7865

Taiwan Office

BCD Semiconductor (Taiwan) Company Limited

4F, 298-1, Rui Guang Road, Nei-Hu District, Taipei, Taiwan
Tel: +886-2-2656 2808
Fax: +886-2-2656 2806

USA Office

BCD Semiconductor Corp.

30920 Huntwood Ave. Hayward, CA 94544, USA
Tel : +1-510-324-2988
Fax: +1-510-324-2788

Компания «Life Electronics» занимается поставками электронных компонентов импортного и отечественного производства от производителей и со складов крупных дистрибьюторов Европы, Америки и Азии.

С конца 2013 года компания активно расширяет линейку поставок компонентов по направлению коаксиальный кабель, кварцевые генераторы и конденсаторы (керамические, пленочные, электролитические), за счёт заключения дистрибьюторских договоров

Мы предлагаем:

- Конкурентоспособные цены и скидки постоянным клиентам.
- Специальные условия для постоянных клиентов.
- Подбор аналогов.
- Поставку компонентов в любых объемах, удовлетворяющих вашим потребностям.
- Приемлемые сроки поставки, возможна ускоренная поставка.
- Доставку товара в любую точку России и стран СНГ.
- Комплексную поставку.
- Работу по проектам и поставку образцов.
- Формирование склада под заказчика.
- Сертификаты соответствия на поставляемую продукцию (по желанию клиента).
- Тестирование поставляемой продукции.
- Поставку компонентов, требующих военную и космическую приемку.
- Входной контроль качества.
- Наличие сертификата ISO.

В составе нашей компании организован Конструкторский отдел, призванный помогать разработчикам, и инженерам.

Конструкторский отдел помогает осуществить:

- Регистрацию проекта у производителя компонентов.
- Техническую поддержку проекта.
- Защиту от снятия компонента с производства.
- Оценку стоимости проекта по компонентам.
- Изготовление тестовой платы монтаж и пусконаладочные работы.



Тел: +7 (812) 336 43 04 (многоканальный)

Email: org@lifeelectronics.ru