

Linear Power Supplies



The Bel Power Solutions produces the industry's broadest selection of Linear power supplies with output voltages from 5 volts through 250 volts. Rugged technology and proven design merge to create quiet, highly-regulated, dependable DC power.

The Linear power supplies are approved to domestic and international regulatory standards, and are CE Marked to the Low Voltage Directive (LVD).

Key Features & Benefits

- RoHS compatible for all six substances
- Worldwide AC Input Capabilities:
100/120/220/230/240 VAC
- $\pm 0.05\%$ Output Regulation
- Low Output Ripple
- Mean Time Before Failure (MTBF) in Excess of 300,000 Hours
- CE marked to Low Voltage Directive
- 100% Burn-In
- 2 Year Warranty
- Overvoltage Protection (OVP) Standard on 5V Single Outputs, Optional for other outputs under 48V

Applications

Used in industrial and medical applications needing low noise/ripple – amplifiers, acoustic, broadcast, ATE and control equipment.

North America

+1-866.513.2839

Asia-Pacific

+86.755.29885888

Europe, Middle East

+353 61 225 977

tech.support@psbel.com
belpowersolutions.com

Linear Power Supplies

Overvoltage Protection Options

These optional overvoltage protection modules are offered for use with Linear Power Supplies. Each is user adjustable from 6.4 V to 34 V.

OVP-12G

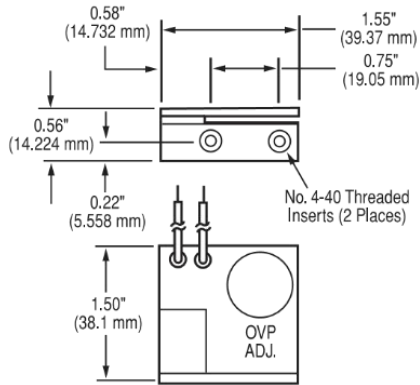
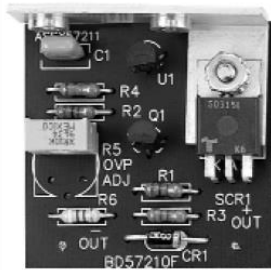

OVP-24G

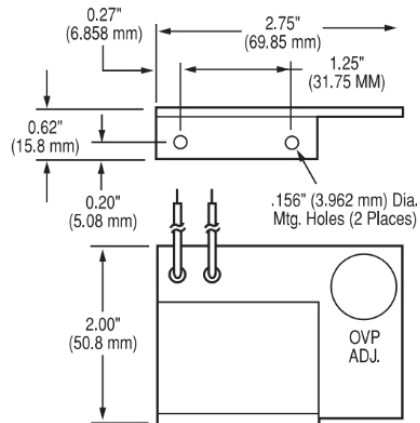
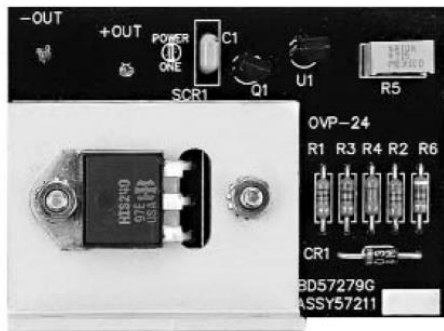

OVP Selection Guide

MODEL	CASE SIZE	OVP MODULES REQUIRED *
SINGLE OUTPUT	B, C, N, D	OVP-12G
	E, F	OVP-24G
DUAL OUTPUT	AA, B, BB, CC	OVP-12G protects both outputs
	E	OVP-24G protects both outputs
TRIPLE OUTPUT	AA, BAA, D CBB, 131 DBB, DCC	OVP-12G protects both 12V through 15V outputs
PEAK CURRENT MODELS	N, BAA, CBB 131	OVP-12G protects any output not provided with built-in OVP

* Outputs with factory built-in OVP are indicated in the Voltage/Current Rating Chart for each model. OVP is not available for 48V through 250V models.

Linear Power Supplies

Model Selection – Single Output

Unsigned output voltages are isolated and can be used as either + or - polarities.

Model Input 100 to 264 VAC	Nominal Vout*	Max Amps	Case Type	Additional Features
5 Vout				
HA5-1.5/OVP-AG	5	1.5	B	A
HB5-3/OVP-AG	5	3	B	A, C
HC5-6/OVP-AG	5	6	C	A, C
HN5-9/OVP-AG	5	9	N	A, C
HD5-12/OVP-AG	5	12	D	A, C
HE5-18/OVP-AG	5	18	E	A, C
F5-25/OVP-AG	5	25	F	A, C, D, H
G5-35/OVP-AG	5	35	F	A, C, D, H
CP197-AG	5	50	F	A, C, D
12 to 15 Vout				
HA15-0.9-AG	12	0.9	B	
HB12-1.7-AG	12	1.7	B	C
HC12-3.4-AG	12	3.4	C	C
HN12-5.1-AG	12	5.1	N	C
HD12-6.8-AG	12	6.8	D	C
HE12-10.2-AG	12	10.2	E	C
F15-15-AG	12	16	F	C, D, H
HA15-0.9-AG	15*	0.9	B	
HB15-1.5-AG	15	1.5	B	C
HC15-3-AG	15	3	C	C
HN15-4.5-AG	15	4.5	N	C
HD15-6-AG	15	6	D	C
HE15-9-AG	15	9	E	C
F15-15-AG	15*	15	F	C, D, H
24 to 28 Vout				
HA24-0.5-AG	24	0.5	B	
HB24-1.2-AG	24	1.2	B	C
HC24-2.4-AG	24	2.4	C	C
HN24-3.6-AG	24	3.6	N	C
HD24-4.8-AG	24	4.8	D	C
HE24-7.2-AG	24	7.2	E	C
F24-12-AG	24	12	F	C, D, H
HA24-0.5-AG	28*	0.5	B	
HB28-1-AG	28	1	B	C
HC28-2-AG1**	28	2	C	C
HN28-3-AG	28	3	N	C
HD28-4-AG	28	4	D	C
HE28-6-AG	28	6	E	C
F24-12-AG	28*	10	F	C, D, H

48 Vout

HB48-0.5-AG	48	0.5	B	
HC48-1-AG	48	1	C	
HD48-3-AG	48	3	D	C
HE48-4-AG	48	4	E	C

* May require jumpering or potentiometer adjustment.

** HC28-2-AG still available

Model numbers highlighted in yellow are not recommended for new designs.

Additional Features:

- A Overvoltage protection, set at 6.2 V ±0.4 V.
- B Non-adjustable 3-terminal regulator.
- C Remote sense provided.
- D With output inhibit and parallel operation master/slave capability.
- E With output inhibit.
- F Adjustable 3-terminal regulator.
- G Can be made into an isolated output by removing jumper W1.
- H Model requires 100 LFM forced-air cooling above 75% of rated output power at 50°C.

Case Type	Dimensions	
	inches	Millimeters
AA	6.50 x 4.00 x 2.10	165.10 x 101.60 x 53.34
B	4.87 x 4.00 x 2.10	123.70 x 101.60 x 53.34
BAA	10.25 x 4.00 x 2.95	260.35 x 101.60 x 74.93
BB	7.00 x 4.87 x 2.95	177.80 x 123.70 x 74.93
C	5.62 x 4.87 x 2.95	142.75 x 123.70 x 74.93
CBB	11.00 x 4.87 x 3.28	279.40 x 123.70 x 83.31
CC	9.38 x 4.87 x 3.28	238.25 x 123.70 x 83.31
CP131	11.00 x 4.87 x 3.28	279.40 x 123.70 x 83.31
D	9.00 x 4.87 x 3.28	228.60 x 123.70 x 83.31
DBB	14.25 x 4.87 x 3.38	361.95 x 123.70 x 85.85
DCC	15.00 x 4.88 x 4.55	381.00 x 123.95 x 115.57
E	14.00 x 4.87 x 3.53	355.60 x 123.70 x 89.66
F	16.75 x 4.88 x 5.00	425.50 x 123.95 x 127.00
N	7.00 x 4.87 x 3.28	177.80 x 123.70 x 83.31

Linear Power Supplies

Model Selection - Dual Output

Unsigned output voltages are isolated and can be used as either + or - polarities.

Model Input 100 to 264 VAC	Nominal Vout*	Max Amps	Case Type	Additional Features
5 V to 15 Vout				
HAA5-1.5/OVP-AG	+5, -5	1.5, 1.5	AA	A
HBB5-3/OVP-AG	+5, -5	3, 3	BB	A
HCC5-6/OVP-AG	+5, -5	6, 6	CC	A, C
HAA512-AG	5, 12 to 15	2, 0.5	AA	A
HBB512-AG	5, 12 to 15	3, 1.25	BB	A, C
HCC512-AG	5, 12 to 15	6, 2.5	CC	A, C
HAA15-0.8-AG	+12, -5*	1, 0.4	AA	C
HBB15-1.5-AG	+12, -5*	1.7, 0.7	BB	C
HAD12-0.4-AG	+12, -12	0.4, 0.4	B	B
HAA15-0.8-AG	+12, -12	1, 1	AA	C
HBB15-1.5-AG	+12, -12	1.7, 1.7	BB	C
HCC15-3-AG	+12, -12	3.4, 3.4	CC	C
HDD15-5-AG	+12, -12*	5, 5	E	C
HAA15-0.8-AG	+12, -15*	1, 0.8	AA	C
HBB15-1.5-AG	+12, -15*	1.7, 1.5	BB	C
HCC15-3-AG	+12, -15*	3.4, 3	CC	C
HDD15-5-AG	+12, -15*	5, 5	E	C
HAA15-0.8-AG	+15, -5*	0.8, 0.4	AA	C
HBB15-1.5-AG	+15, -5*	1.5, 0.7	BB	C
HAA15-0.8-AG	+15, -12*	0.8, 1	AA	C
HBB15-1.5-AG	+15, -12*	1.5, 1.7	BB	C
HCC15-3-AG	+15, -12*	3, 3.4	CC	C
HDD15-5-AG	15, -12*	5, 5	E	C
15 V to 24 Vout				
HAD15-0.4-AG	+15, -15	0.4, 0.4	B	B
HAA15-0.8-AG	+15, -15	0.8, 0.8	AA	C
HBB15-1.5-AG	+15, -15*	1.5, 1.5	BB	C
HCC15-3-AG	+15, -15*	3, 3	CC	C
HDD15-5-AG	+15, -15	5, 5	E	C
HAA24-0.6-AG	+24, -24	0.6, 0.6	AA	
HBB24-1.2-AG	+24, -24	1.2, 1.2	BB	
HCC24-2.4-AG	+24, -24	2.4, 2.4	CC	C

* May require jumpering or potentiometer adjustment.

Model numbers highlighted in yellow are not recommended for new designs.

Additional Features:

- A Overvoltage protection, set at 6.2 V \pm 0.4 V.
- B Non-adjustable 3-terminal regulator.
- C Remote sense provided.
- D With output inhibit and parallel operation master/slave capability.
- E With output inhibit.
- F Adjustable 3-terminal regulator.
- G Can be made into an isolated output by removing jumper W1.
- H Model requires 100 LFM forced-air cooling above 75% of rated output power at 50°C.

Case Type	Dimensions	
	inches	Millimeters
AA	6.50 x 4.00 x 2.10	165.10 x 101.60 x 53.34
B	4.87 x 4.00 x 2.10	123.70 x 101.60 x 53.34
BAA	10.25 x 4.00 x 2.95	260.35 x 101.60 x 74.93
BB	7.00 x 4.87 x 2.95	177.80 x 123.70 x 74.93
C	5.62 x 4.87 x 2.95	142.75 x 123.70 x 74.93
CBB	11.00 x 4.87 x 3.28	279.40 x 123.70 x 83.31
CC	9.38 x 4.87 x 3.28	238.25 x 123.70 x 83.31
CP131	11.00 x 4.87 x 3.28	279.40 x 123.70 x 83.31
D	9.00 x 4.87 x 3.28	228.60 x 123.70 x 83.31
DBB	14.25 x 4.87 x 3.38	361.95 x 123.70 x 85.85
DCC	15.00 x 4.88 x 4.55	381.00 x 123.95 x 115.57
E	14.00 x 4.87 x 3.53	355.60 x 123.70 x 89.66
F	16.75 x 4.88 x 5.00	425.50 x 123.95 x 127.00
N	7.00 x 4.87 x 3.28	177.80 x 123.70 x 83.31

Linear Power Supplies

Model Selection - Triple Output

Unsigned output voltages are isolated and can be used as either + or - polarities.

Model Input 100 to 264 VAC	Nominal Vout*	Max Amps	Case Type	Additional Features
5 V to 24 Vout				
HTAA-16W-AG	+5, +12, -5*	2, 0.4, 0.4	AA	A
HBAA-40W-AG	5, +12, -5*	3, 1, 0.4	BAA	A, C
HCAA-60W-AG	+5, +12, -5*	6, 1, 0.4	D	A, C
HCBB-75W-AG	5, +12, -5*	6, 1.7, 0.7	CBB	C
CP131-AG	5, +12, -5*	8, 1.7, 0.7	CP131	A, C
HDBB-105W-AG	5, +12, -5*	12, 1.7, 0.7	DBB	A, C
HTAA-16W-AG	5, +12, -12	2, 0.4, 0.4	AA	A
HBAA-40W-AG	5, +12, -12	3, 1, 1	BAA	A, C
HCAA-60W-AG	+5, +12, -12	6, 1, 1	D	A, C
HCBB-75W-AG	5, +12, -12	6, 1.7, 1.7	CBB	C
CP131-AG	5, +12, -12	8, 1.7, 1.7	CP131	A, C
HDBB-105W-AG	5, +12, -12	12, 1.7, 1.7	DBB	C
HDCC-150W-AG	5, +12, -12	12, 3.4, 3.4	DCC	A, C
HTAA-16W-AG	5, +12, -15*	2, 0.4, 0.4	AA	A
HBAA-40W-AG	5, +12, -15*	3, 1, 0.8	BAA	A, C
HCAA-60W-AG	+5, +12, -15*	6, 1, 1	D	A, C
HCBB-75W-AG	5, +12, -15	6, 1.7, 1.5	CBB	C
CP131-AG	5, +12, -15	8, 1.7, 1.5	CP131	A, C
HDBB-105W-AG	5, +12, -15*	12, 1.7, 1.5	DBB	C
HDCC-150W-AG	5, +12, -15	12, 3.4, 3	DCC	A, C
HTAA-16W-AG	5, +15, -5*	2, 0.4, 0.4	AA	A
HBAA-40W-AG	5, +15, -5*	3, 0.8, 0.4	BAA	A, C
HCAA-60W-AG	+5, +15, -5*	6, 1, 0.4	D	A, C
HCBB-75W-AG	5, +15, -5*	6, 1.5, 0.7	CBB	C
CP131-AG	5, +15, -5*	8, 1.5, 0.7	CP131	A,
HDBB-105W-AG	5, +15, -5*	12, 1.5, 0.7	DBB	C
HTAA-16W-AG	5, +15, -12*	2, 0.4, 0.4	AA	A
HBAA-40W-AG	5, +15, -12*	3, 0.8, 1	BAA	A, C
HCAA-60W-AG	+5, +15, -12*	6, 1, 1	D	A, C
HCBB-75W-AG	5, +15, -12	6, 1.5, 1.7	CBB	C
CP131-AG	5, +15, -12	8, 1.5, 1.7	CP131	A, C
HDBB-105W-AG	5, +15, -12*	12, 1.5, 1.7	DBB	C
HDCC-150W-AG	5, +15, -12	12, 3, 3.4	DCC	A, C
HTAA-16W-AG	5, +15, -15*	2, 0.4, 0.4	AA	A
HBAA-40W-AG	5, +15, -15*	3, 0.8, 0.8	BAA	A, C
HCAA-60W-AG	+5, +15, -15*	6, 1, 1	D	A, C
HCBB-75W-AG	5, +15, -15	6, 1.5, 1.5	CBB	C
CP131-AG	5, +15, -15	8, 1.5, 1.5	CP131	A, C
HDBB-105W-AG	5, +15, -15*	12, 1.5, 1.5	DBB	C
HDCC-150W-AG	5, +15, -15	12, 3, 3	DCC	A, C

Additional Features:

- A Overvoltage protection, set at 6.2 V \pm 0.4 V.
- B Non-adjustable 3-terminal regulator.
- C Remote sense provided.
- D With output inhibit and parallel operation master/slave capability.
- E With output inhibit.
- F Adjustable 3-terminal regulator.
- G Can be made into an isolated output by removing jumper W1.
- H Model requires 100 LFM forced-air cooling above 75% of rated output power at 50°C.

Case Type	Dimensions	
	inches	Millimeters
AA	6.50 x 4.00 x 2.10	165.10 x 101.60 x 53.34
B	4.87 x 4.00 x 2.10	123.70 x 101.60 x 53.34
BAA	10.25 x 4.00 x 2.95	260.35 x 101.60 x 74.93
BB	7.00 x 4.87 x 2.95	177.80 x 123.70 x 74.93
C	5.62 x 4.87 x 2.95	142.75 x 123.70 x 74.93
CBB	11.00 x 4.87 x 3.28	279.40 x 123.70 x 83.31
CC	9.38 x 4.87 x 3.28	238.25 x 123.70 x 83.31
CP131	11.00 x 4.87 x 3.28	279.40 x 123.70 x 83.31
D	9.00 x 4.87 x 3.28	228.60 x 123.70 x 83.31
DBB	14.25 x 4.87 x 3.38	361.95 x 123.70 x 85.85
DCC	15.00 x 4.88 x 4.55	381.00 x 123.95 x 115.57
E	14.00 x 4.87 x 3.53	355.60 x 123.70 x 89.66
F	16.75 x 4.88 x 5.00	425.50 x 123.95 x 127.00
N	7.00 x 4.87 x 3.28	177.80 x 123.70 x 83.31

* May require jumpering or potentiometer adjustment.

Model numbers highlighted in yellow are not recommended for new designs.

Linear Power Supplies

Input Specifications

PARAMETER	CONDITIONS / DESCRIPTION	MIN	NOM	MAX	UNITS	
AC Input Voltage ^{1,2}	Jumper selectable, shipped factory configured for 120 VAC operation. All models must be externally fused for proper operation.	100 VAC Tap	87	100	110	VAC
		120 VAC Tap	104	120	132	
	Fuse ratings are marked on each unit.	220 VAC Tap	191	220	242	
	Consult factory for each unit's fuse requirements.	240 VAC Tap	209	240	264	
Input Frequency	AC input.	47		63	Hz	
Line Regulation	Output voltage change for a 10% line change: F case models.	-0.01		+0.01	%	
	HAD12, HAD15.	-1.0		+1.0		
	Outputs with adjustable three terminal regulators.	-0.5		+0.5		
	All other models.	-0.05		+0.05		

Output Specifications

PARAMETER	CONDITIONS / DESCRIPTION	MIN	NOM	MAX	UNITS
Output Adjustment	Minimum output adjustment range ³	-5		+5	%
Efficiency	5 volt outputs.		45		%
	12 volt and 15 volt outputs.		55		
	24 volt and higher outputs.		60		
Ripple and Noise ⁴	F case models.			3.0	mV _{PK-PK}
	5 volt, 12 volt, and 15 volt models.			5.0	mV _{PK-PK}
	All three terminal regulator outputs.			0.2	% _{PK-PK}
	24 volt through 250 volt models.			3.0 mV _{PK-PK} plus 0.02% of output voltage, max	
Load Regulation	Output change for a 50% load change: F case models.	-0.02		+0.02	%
	HAD12, HAD15.	-1		+1	
	Outputs with adjustable three terminal regulators.	-0.5		+0.5	
	All other models.	-0.05		+0.05	
Transient Response	Recovery time, to within 1% of initial set point due to a 50% load change.			50	μs

Safety, Regulatory, and EMI Specifications

PARAMETER	CONDITIONS / DESCRIPTION	MIN	NOM	MAX	UNITS
Agency Approvals	Approved to the latest edition of the following standards; UL/CSA60950-1 2nd, IEC60950-1 2nd and EN60950-1 2nd.				
Dielectric Withstand Voltage	Input to case	2121			VDC
	Input to output (tested by manufacturer only)	4242			
Electromagnetic Interference	FCC CFR title 47 Part 15 Sub-Part B - conducted.				
Interference	EN55022 / CISPR 22 conducted. EN55022 / CISPR 22 radiated.				Compatible with system compliance to Level B.
Leakage Current	Per EN60950	(264 VAC)	23	50	μA

¹ Derate output current 10% for 50Hz operation.

² Input voltage tolerance for 230VAC operation is +15%, -10%.

³ Output voltage adjustments can be made to within ±5% of factory setting of nominal output voltage.

Locate the "Vadj" potentiometer on the power supply PCB and use a screwdriver to adjust the output pot.

The HAD12 and HAD15 3 terminal regulator outputs are not adjustable.

⁴ Full load, 20MHz bandwidth.

Linear Power Supplies

Interface Signals and Internal Protection

PARAMETER	CONDITIONS / DESCRIPTION	MIN	NOM	MAX	UNITS
Overvoltage Protection	Provided on 5 volt output units where indicated. Other outputs may use optional overvoltage protectors OVP-12 and OVP-24.	5.8		6.6	V
Remote Sense	Total voltage compensation for cable losses with respect to the main output. Provided on models where indicated.			250	mV
Overcurrent/Short Circuit Protection	Automatic current limit/foldback. Rated as a percentage of output power.	115	120	140	%
Master/Slave Operation	For parallel operation of up to 6 units. Master/slave pin provided on F case models only. Contact factory for application notes.				

Environmental Specifications

PARAMETER	CONDITIONS/DESCRIPTION	MIN	NOM	MAX	UNITS
Operating Temperature	Derate output power linearly above 50°C by 3% per °C. @ 100% load	0		50	°C
	@ 40% load			70	°C
Storage Temperature		-40		85	°C
Temperature Coefficient	0°C to 50°C (after 15 minute warm-up).		0.1	0.3	%/°C
	24 hours after warm-up.	-0.3		+0.3	%
Shock	Operating.			20	GPK
Vibration	Random vibration from 10 Hz to 2 kHz, 3 axis.			6.15	GRMS
Relative Humidity	Non-Condensing.	5		95	%RH

Mechanical Dimensions of Case Types

AA CASE

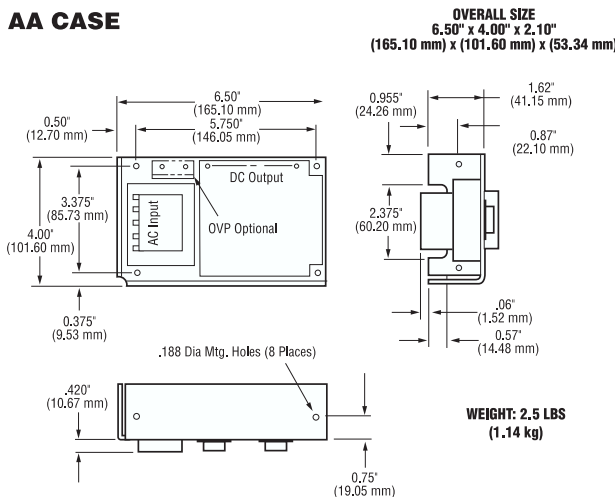

BAA CASE

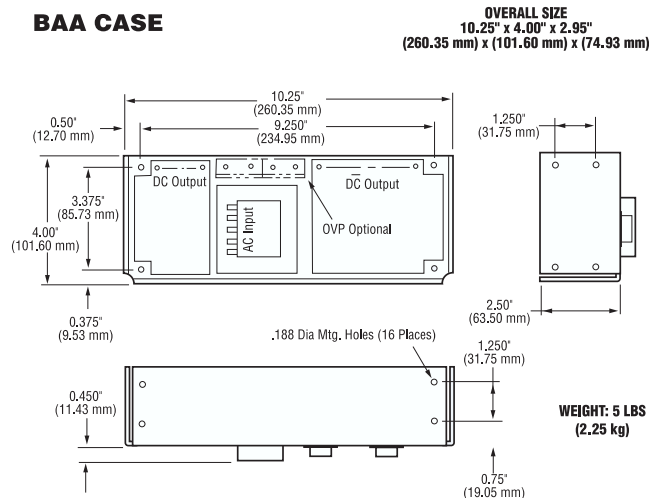

Linear Power Supplies

B CASE

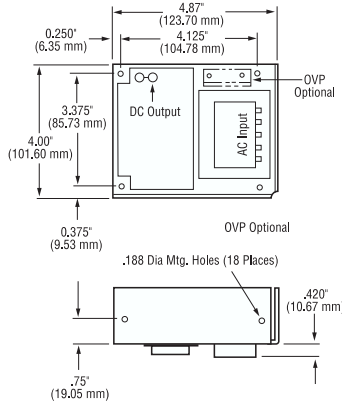

OVERALL SIZE
4.87" x 4.00" x 2.10"
(123.70 mm) x (101.60 mm) x (53.34 mm)

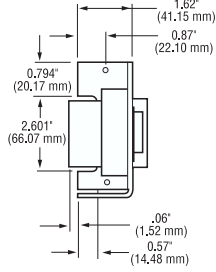

WEIGHT: 2.2 LBS
(1.0 kg)

C CASE

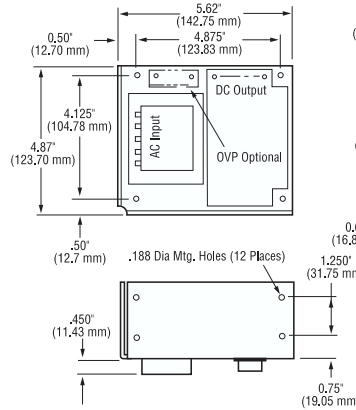

OVERALL SIZE
5.62" x 4.87" x 2.95"
(142.75 mm) x (123.70 mm) x (74.93 mm)

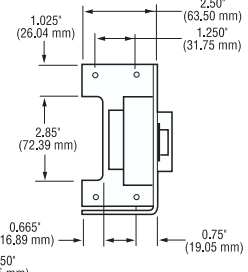

WEIGHT: 4.25 LBS
(1.93 kg)

BB CASE

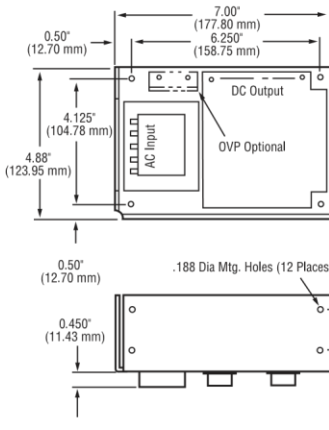

OVERALL SIZE
7.00" x 4.87" x 2.95"
(177.80 mm) x (123.70 mm) x (74.93 mm)

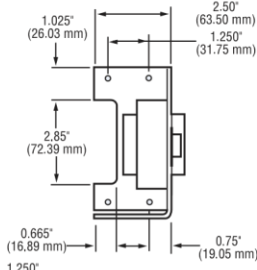

WEIGHT: 4.4 LBS
(2.0 kg)

CC CASE

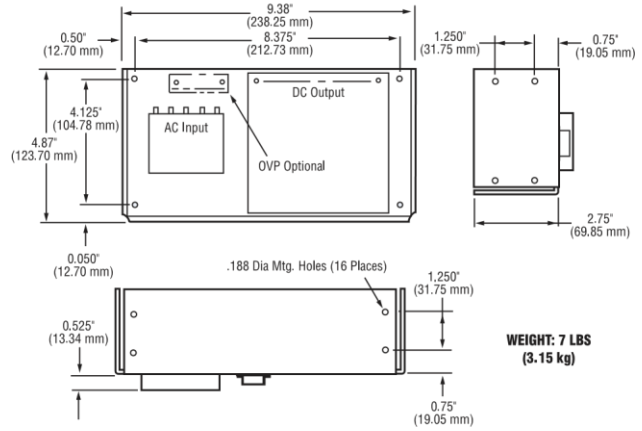

OVERALL SIZE
9.38" x 4.87" x 3.28"
(238.25 mm) x (123.70 mm) x (83.31 mm)

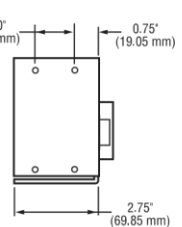

WEIGHT: 7 LBS
(3.15 kg)

CBB CASE

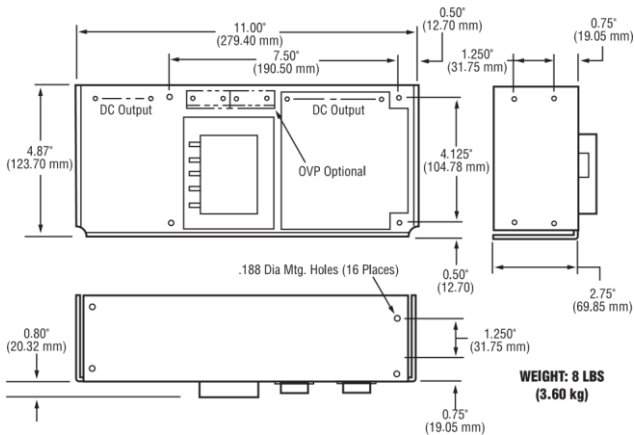

OVERALL SIZE
11.00" x 4.87" x 3.28"
(279.40 mm) x (123.70 mm) x (83.31 mm)

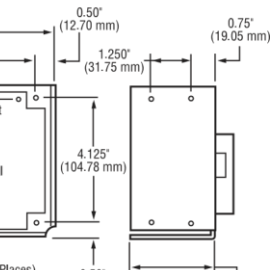

WEIGHT: 8 LBS
(3.60 kg)

DCC CASE

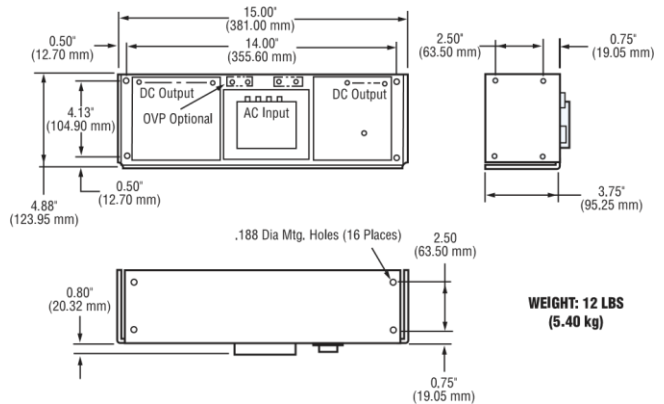

OVERALL SIZE
15.00" x 4.88" x 4.55"
(381.00 mm) x (123.95 mm) x (115.57 mm)

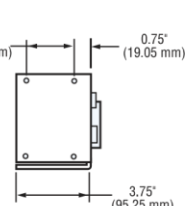

WEIGHT: 12 LBS
(5.40 kg)

Linear Power Supplies

D CASE

OVERALL SIZE
9.00" x 4.87" x 3.28"
(228.60 mm) x (123.70 mm) x (83.31 mm)

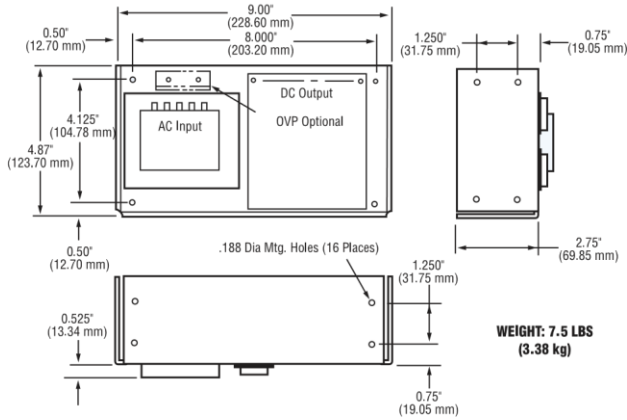

E CASE

OVERALL SIZE
14.00" x 4.87" x 3.53"
(355.60 mm) x (123.70 mm) x (89.66 mm)

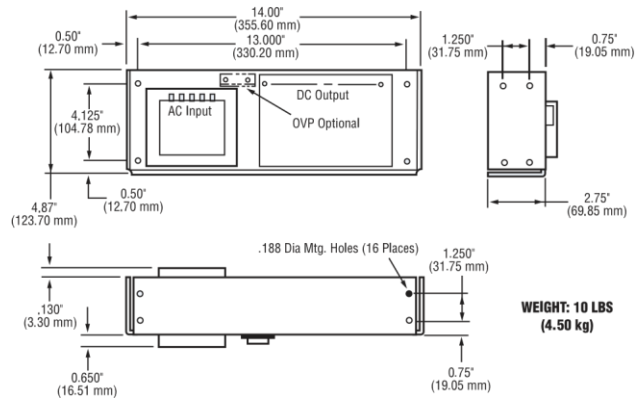

DBB CASE

OVERALL SIZE
14.25" x 4.87" x 3.38"
(361.95 mm) x (123.70 mm) x (85.85 mm)

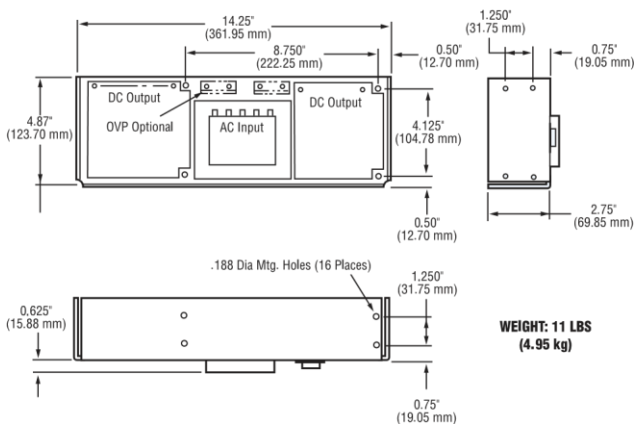

F CASE

OVERALL SIZE
16.75" x 4.88" x 5.00"
(425.5 mm) x (123.95 mm) x (127.00 mm)

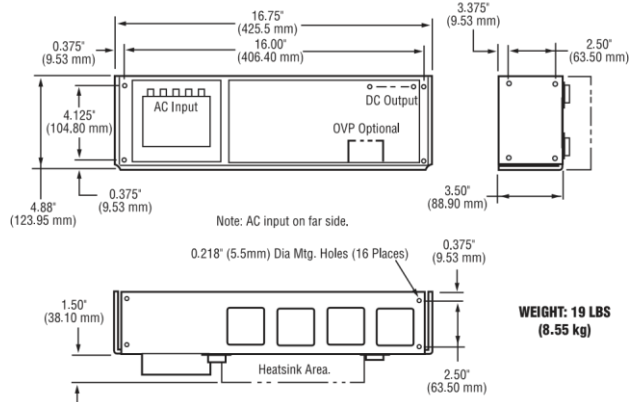

N CASE

OVERALL SIZE
7.00" x 4.87" x 3.28"
(177.80 mm) x (123.70 mm) x (83.31 mm)

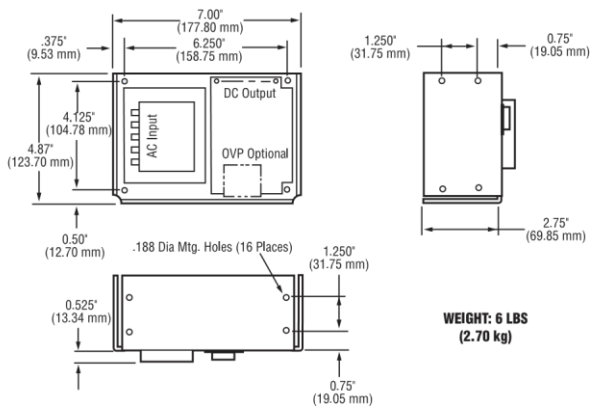

CP510-A CASE

OVERALL SIZE
8.25" x 4.87" x 3.28"
(209.55 mm) x (123.70 mm) x (83.31 mm)

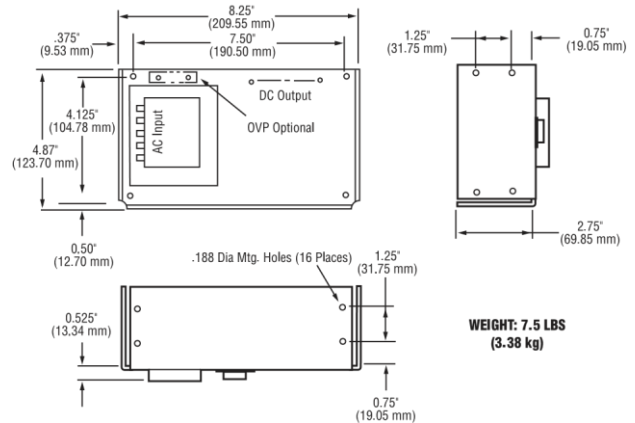

866.513.2839

tech.support@psbel.com

belpowersolutions.com

Linear Power Supplies

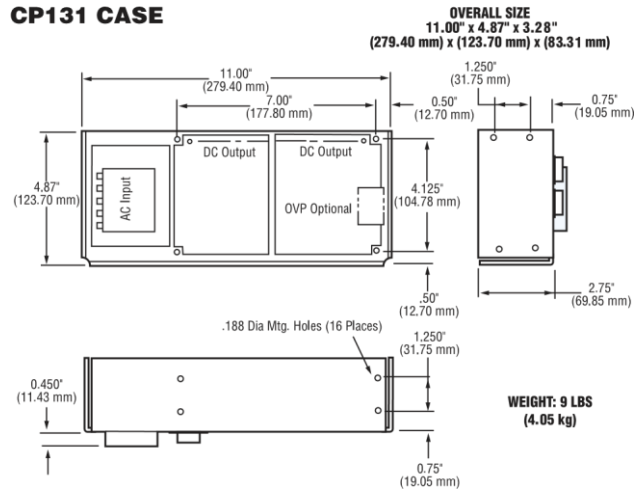

For more information on these products consult: tech.support@psbel.com

NUCLEAR AND MEDICAL APPLICATIONS - Products are not designed or intended for use as critical components in life support systems, equipment used in hazardous environments, or nuclear control systems.

TECHNICAL REVISIONS - The appearance of products, including safety agency certifications pictured on labels, may change depending on the date manufactured. Specifications are subject to change without notice.

Компания «Life Electronics» занимается поставками электронных компонентов импортного и отечественного производства от производителей и со складов крупных дистрибьюторов Европы, Америки и Азии.

С конца 2013 года компания активно расширяет линейку поставок компонентов по направлению коаксиальный кабель, кварцевые генераторы и конденсаторы (керамические, пленочные, электролитические), за счёт заключения дистрибьюторских договоров

Мы предлагаем:

- Конкурентоспособные цены и скидки постоянным клиентам.
- Специальные условия для постоянных клиентов.
- Подбор аналогов.
- Поставку компонентов в любых объемах, удовлетворяющих вашим потребностям.
- Приемлемые сроки поставки, возможна ускоренная поставка.
- Доставку товара в любую точку России и стран СНГ.
- Комплексную поставку.
- Работу по проектам и поставку образцов.
- Формирование склада под заказчика.
- Сертификаты соответствия на поставляемую продукцию (по желанию клиента).
- Тестирование поставляемой продукции.
- Поставку компонентов, требующих военную и космическую приемку.
- Входной контроль качества.
- Наличие сертификата ISO.

В составе нашей компании организован Конструкторский отдел, призванный помогать разработчикам, и инженерам.

Конструкторский отдел помогает осуществить:

- Регистрацию проекта у производителя компонентов.
- Техническую поддержку проекта.
- Защиту от снятия компонента с производства.
- Оценку стоимости проекта по компонентам.
- Изготовление тестовой платы монтаж и пусконаладочные работы.



Тел: +7 (812) 336 43 04 (многоканальный)

Email: org@lifeelectronics.ru