

Index Spare Parts

Modell	Page	Modell	Page
DSVT 80	103	WSD 150	150
DSX 80	104	WSD 151	151
DSXV 80	105	WSD 161	152
FE 25	106	WSF 80D	153
FE 50	107	WSF 81D	154
FE 50M	108	WT 50	155
FE 75	109	WTCP 51	156
FE 80	110		
MLR 21 FE	111		
MPR 80	112		
MT 1500	113		
PUD 80R	114		
PUD 81R	115		
Pyropen + Pyropen Piezo	116		
Pyropen JR.	117		
SFA	118		
SFA / SFC	119		
WAD 100	120		
WAD 101	121		
WDD 80V	122		
WDD 81V	123		
WDD 161V	124		
WFE	125		
WFE 2S	126		
WFE 3S	127		
WFE 4S	128		
WFE P(2)	129		
WFE P	130		
WHA 300	131		
WHA 700	132		
WHA 2000	133		
WHP 300	134		
WMA 3V	135		
WMD 1	136		
WMD 1S	137		
WMD 3	138		
WS 50	139		
WS 51	140		
WS 80	141		
WS 81	142		
WSA 1	143		
WSA 1R	144		
WSA 1V	145		
WSD 50	146		
WSD 80	147		
WSD 81	148		
WSD 130	149		

DSVT 80

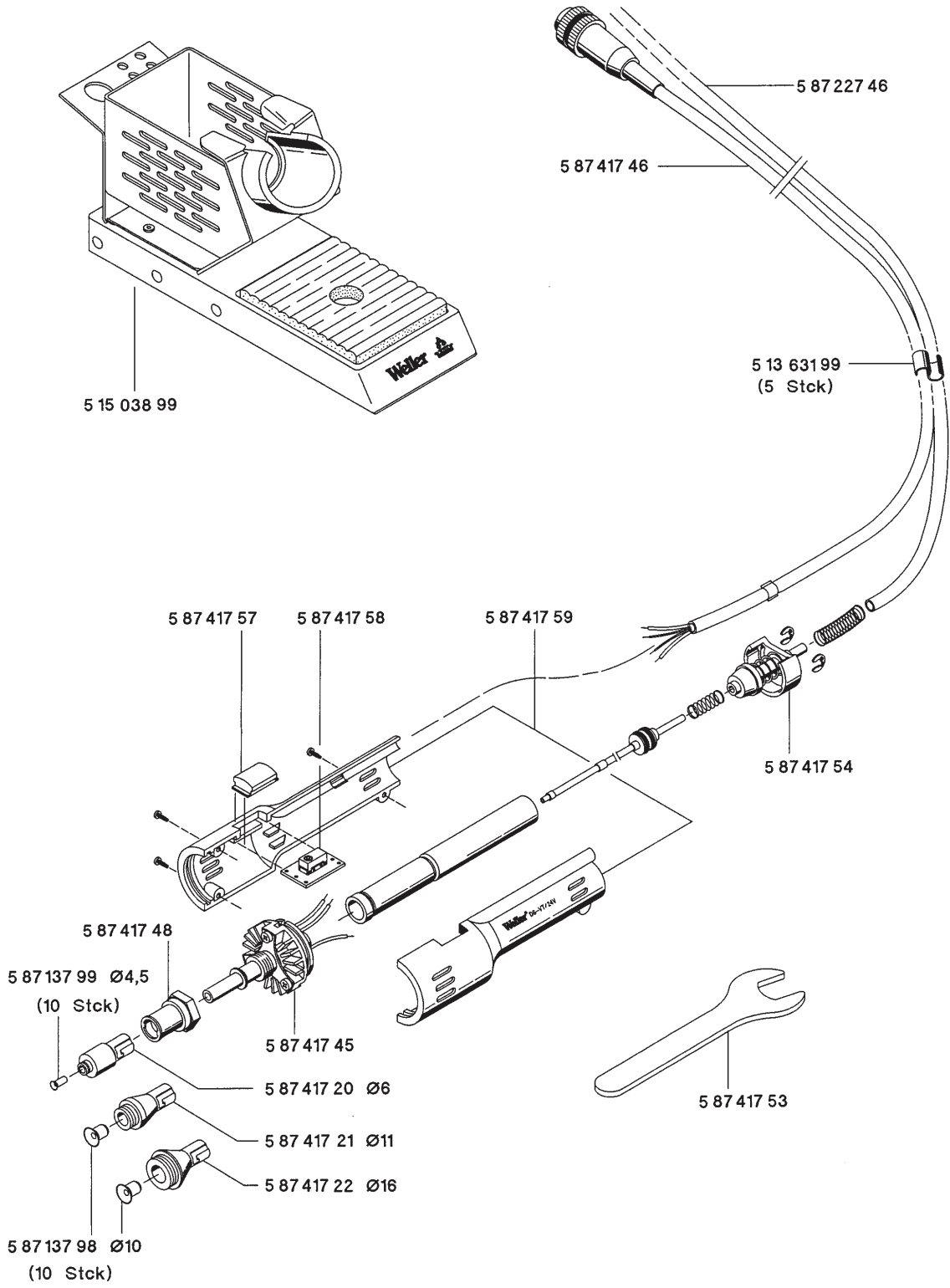

4D2R419/3

4D2R419/3
26.09.01 / Martin

DSX 80

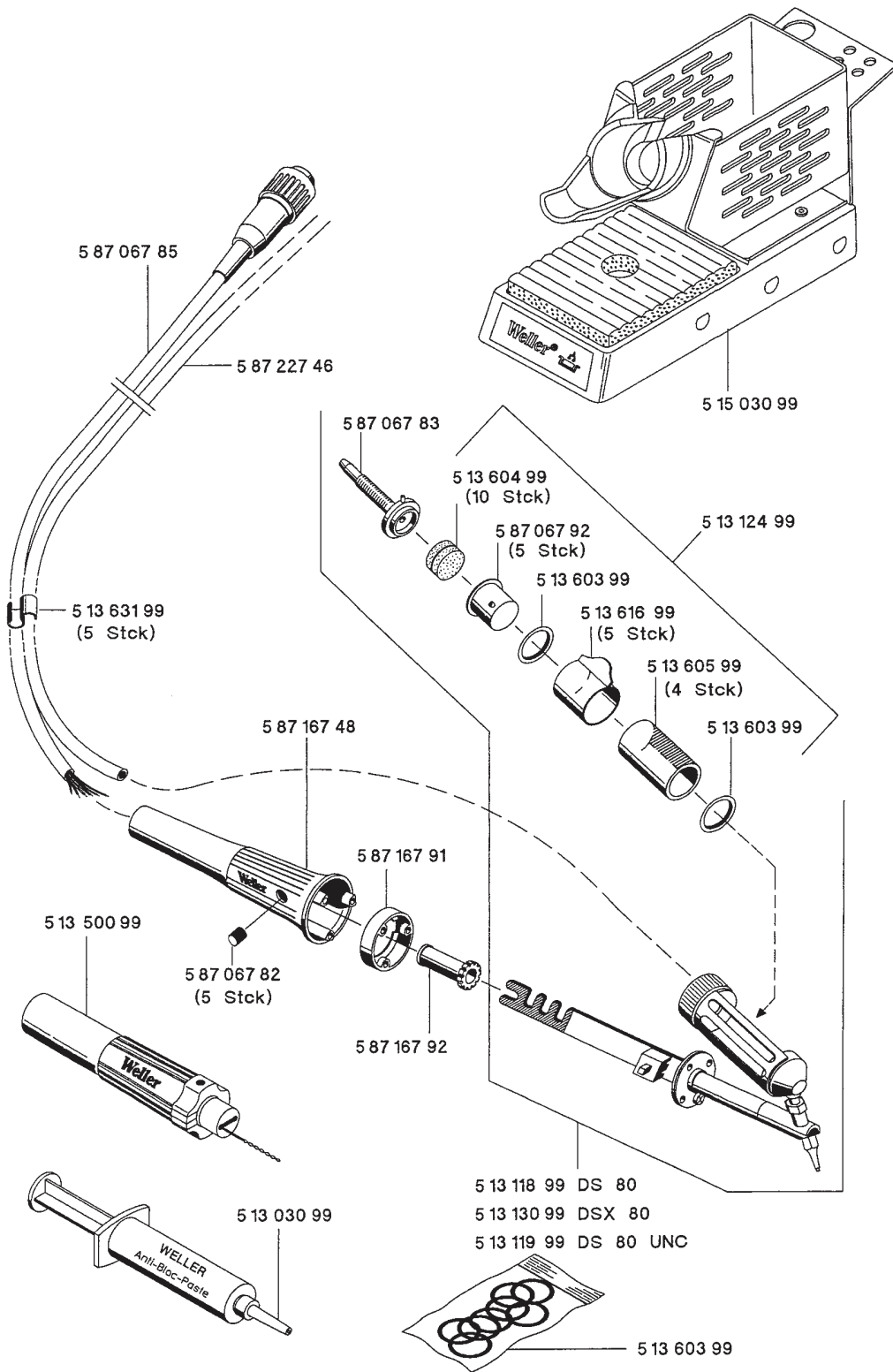

4D2R645/5

4D2R645/5
28.09.01 / Martin

DSXV 80

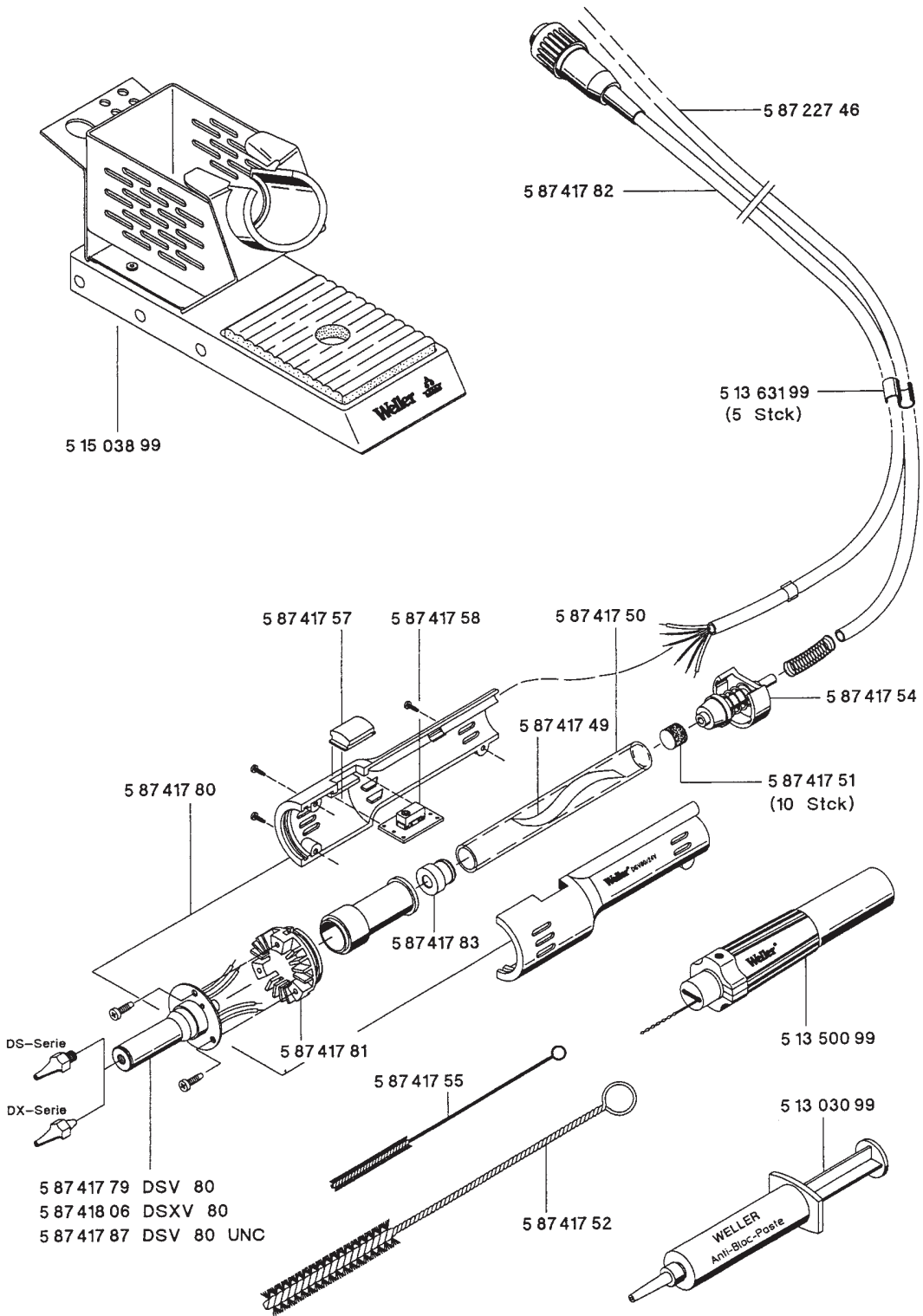

FE 25

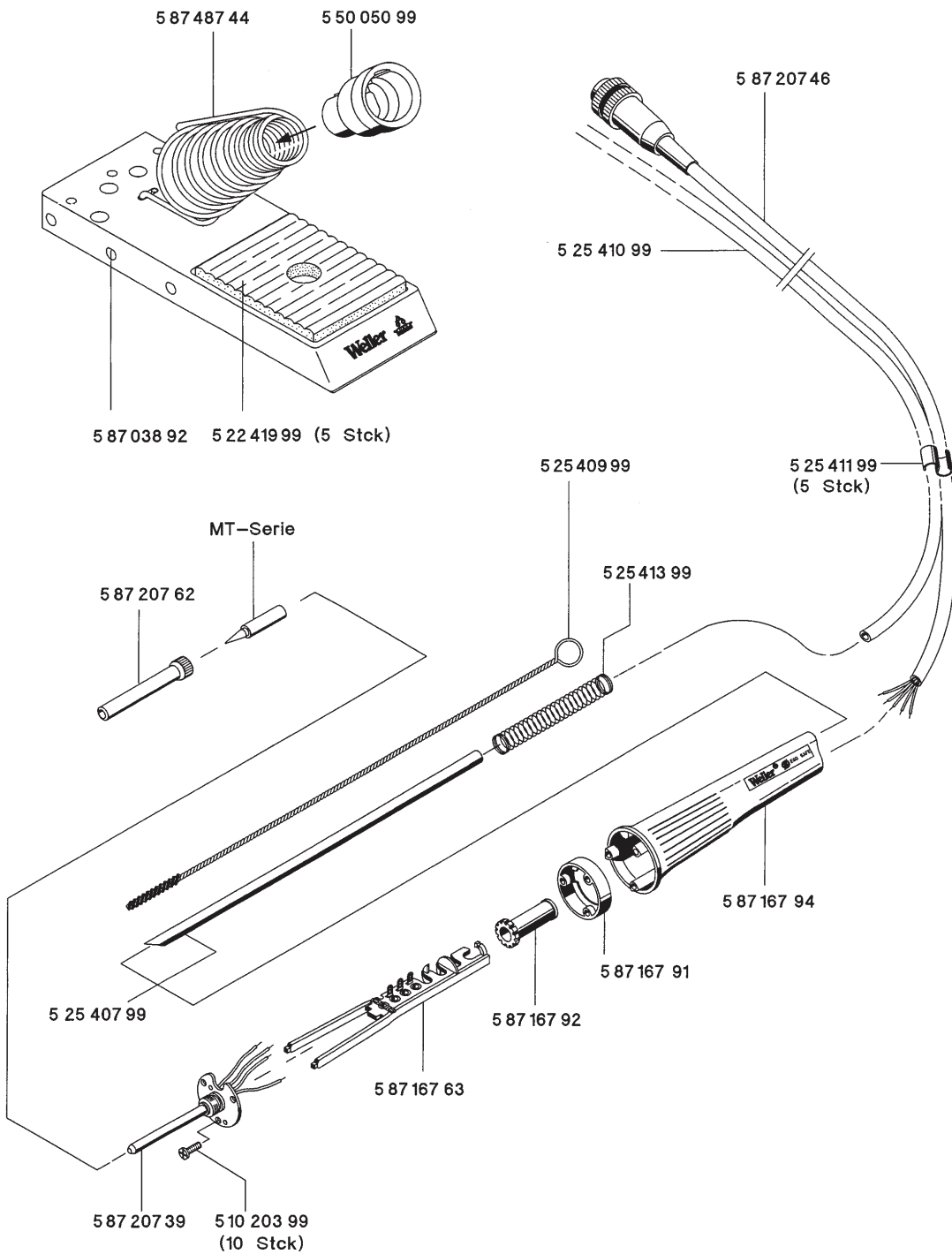

4D2R354/4

4D2R354/4
26.09.01 / Martin

FE 50

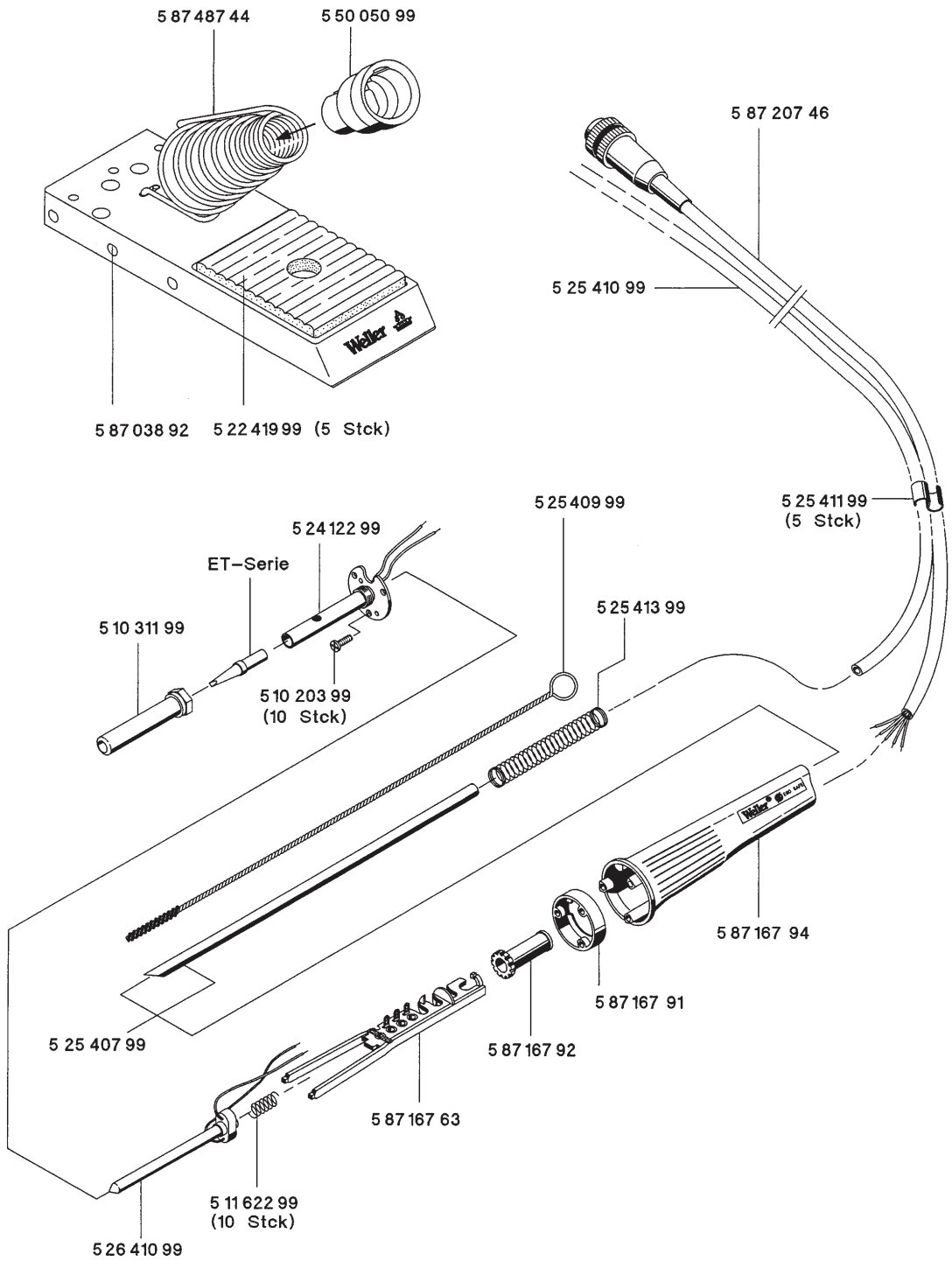

4D2R355/5

4D2R355/5
26.09.01 / Martin

FE 50M

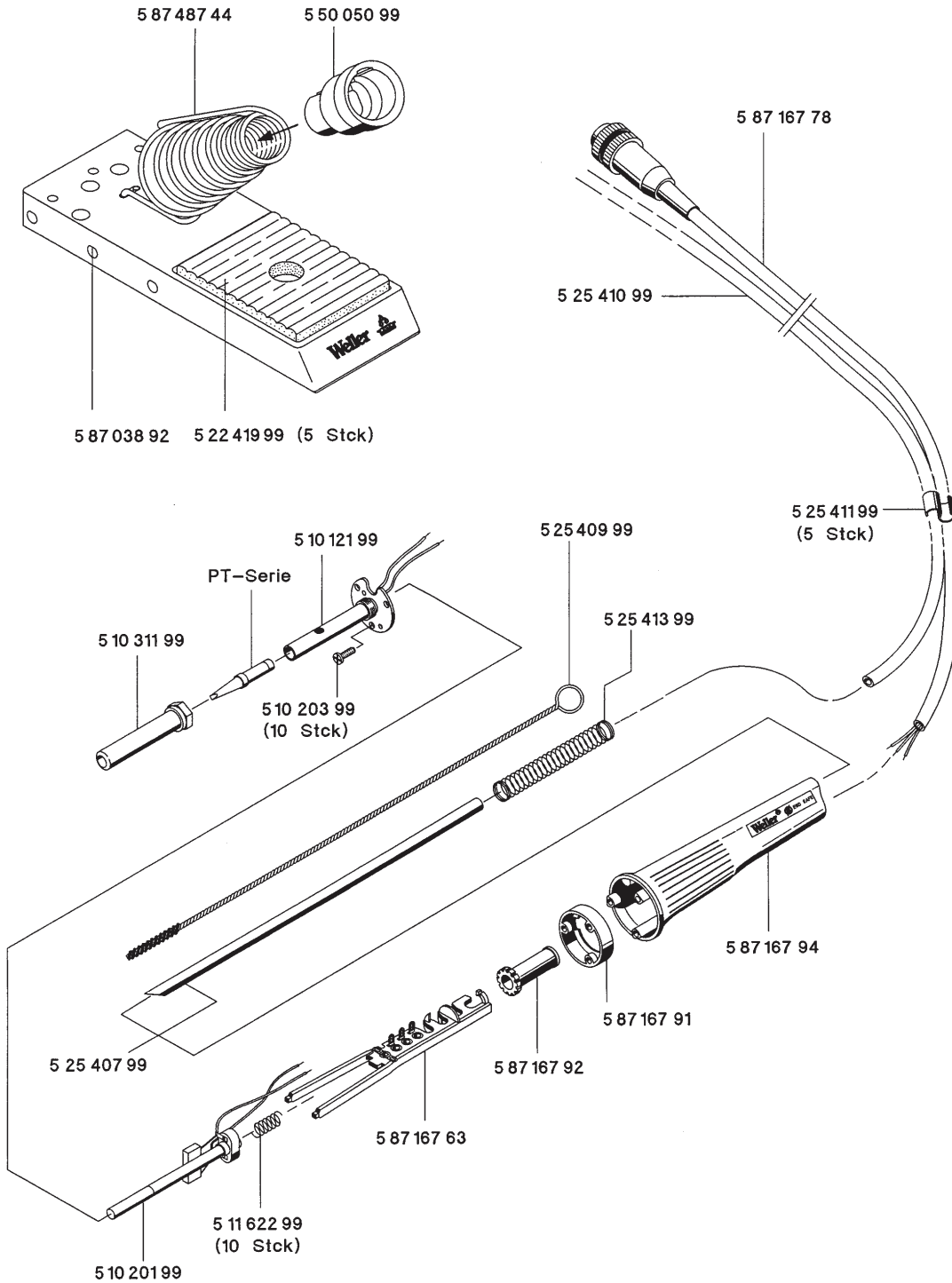

4D2R356/3

4D2R356/3
26.09.01 / Herten

FE 75

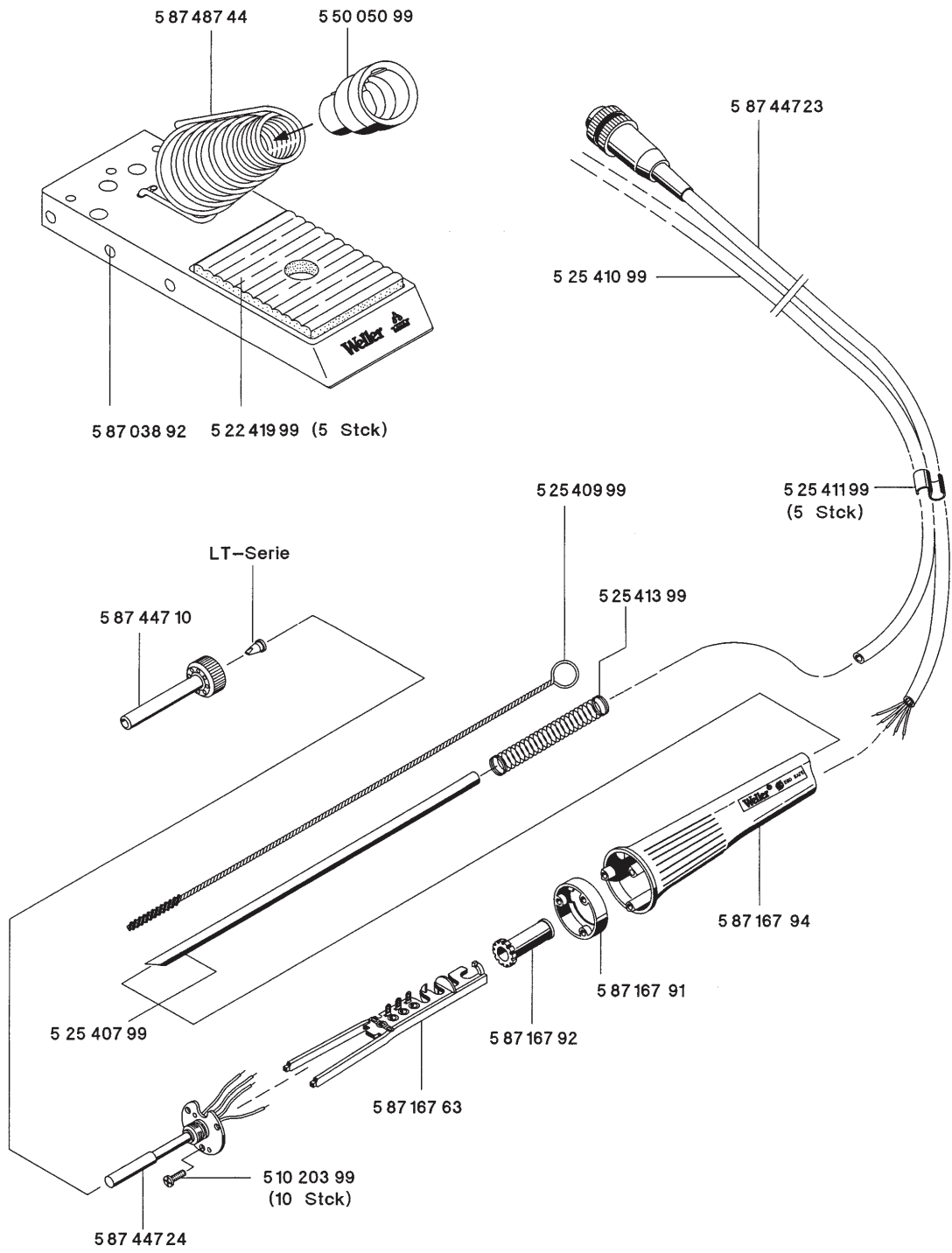

4D9R558/3

4D9R558/3
26.09.01 / Martin

FE 80

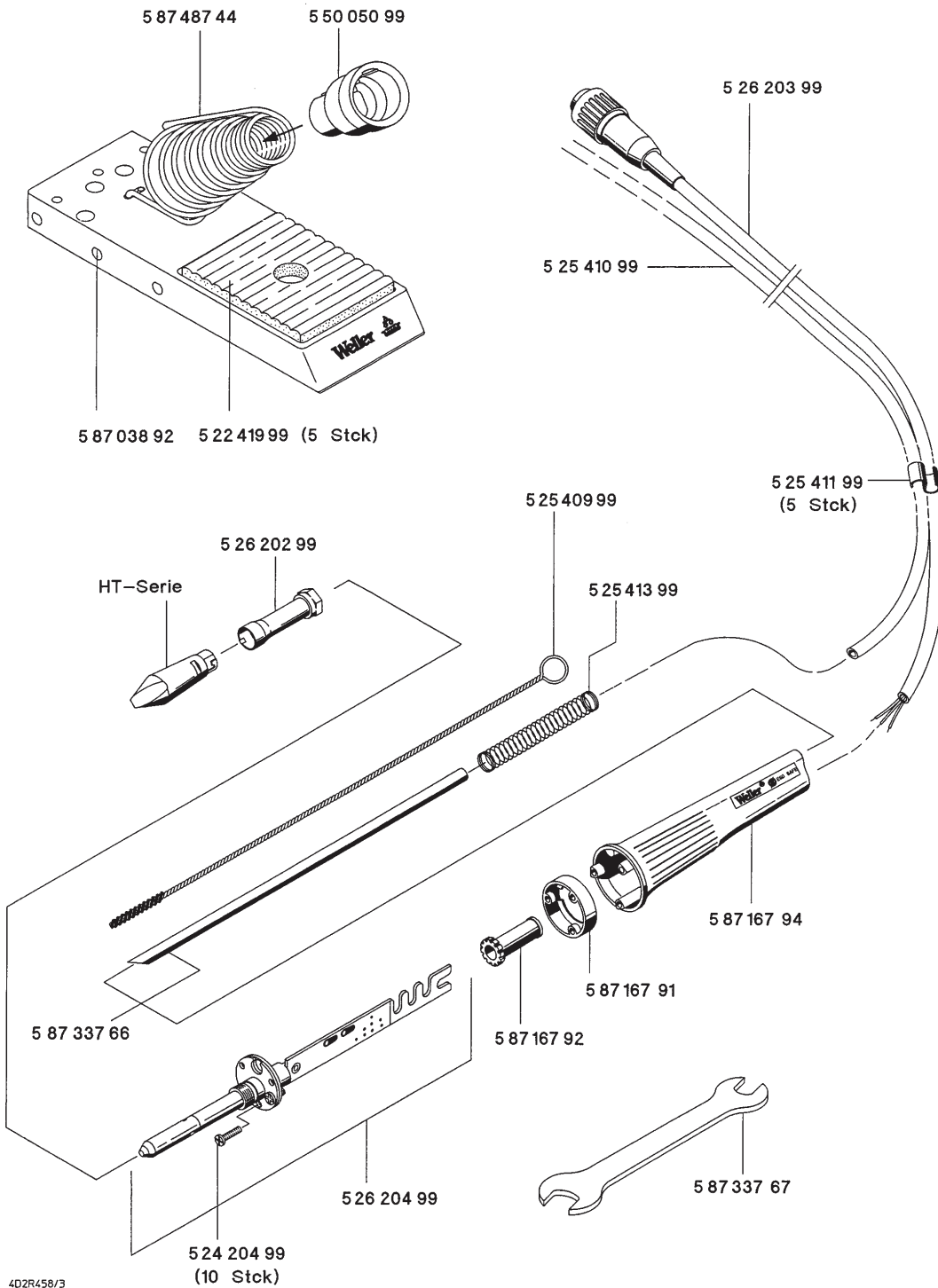

4D2R458/3
26.09.01 / Morin

MLR 21FE

Weller®

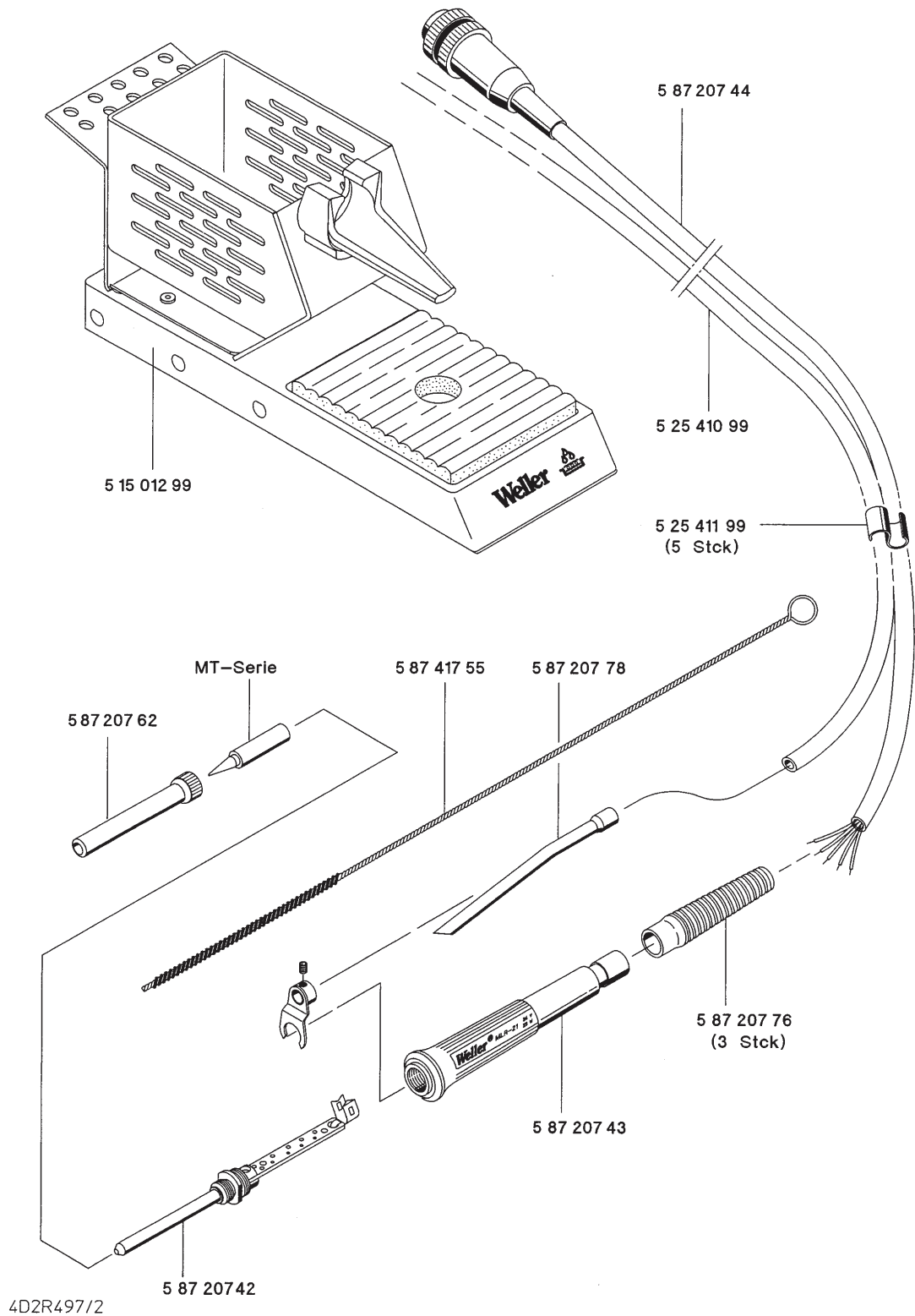

MPR 80

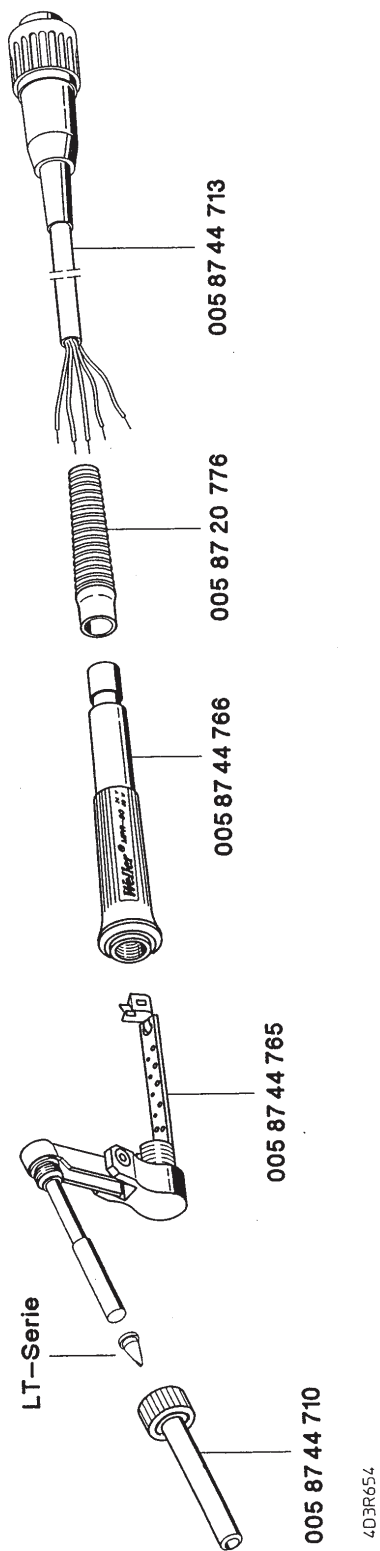

403R654
2008/997/10der

MT 1500

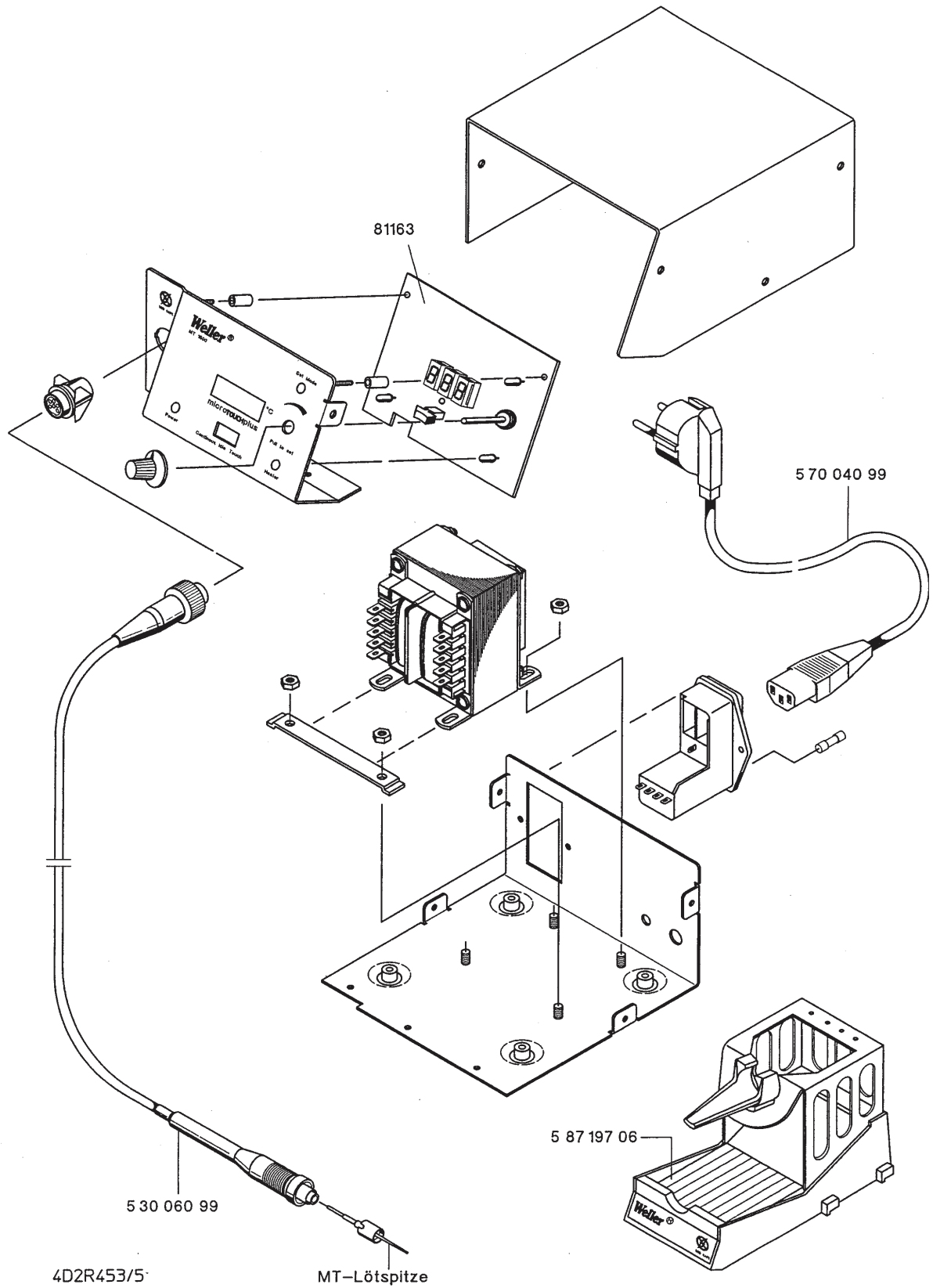

PUD 80R

Weller®

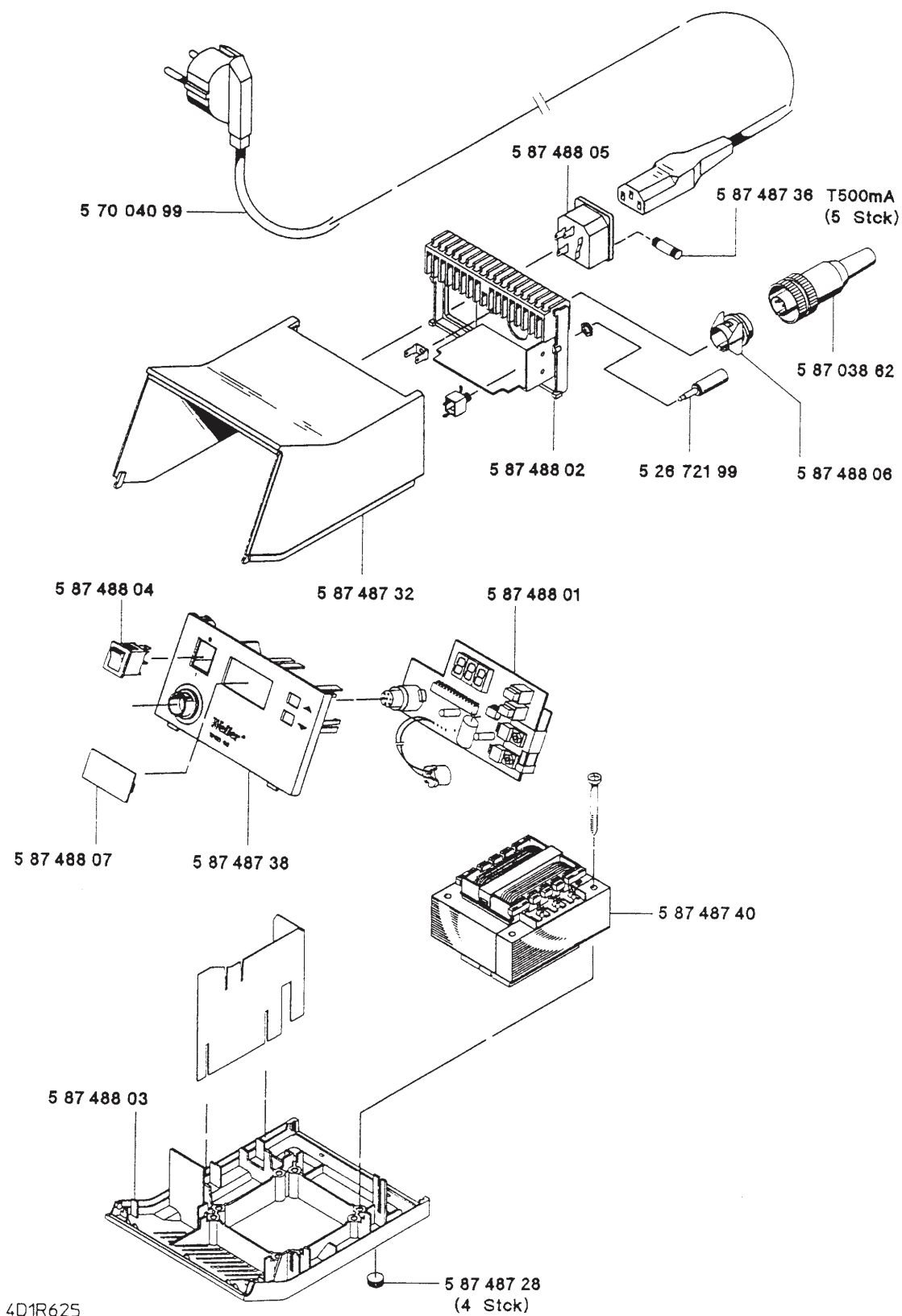

PUD 81R

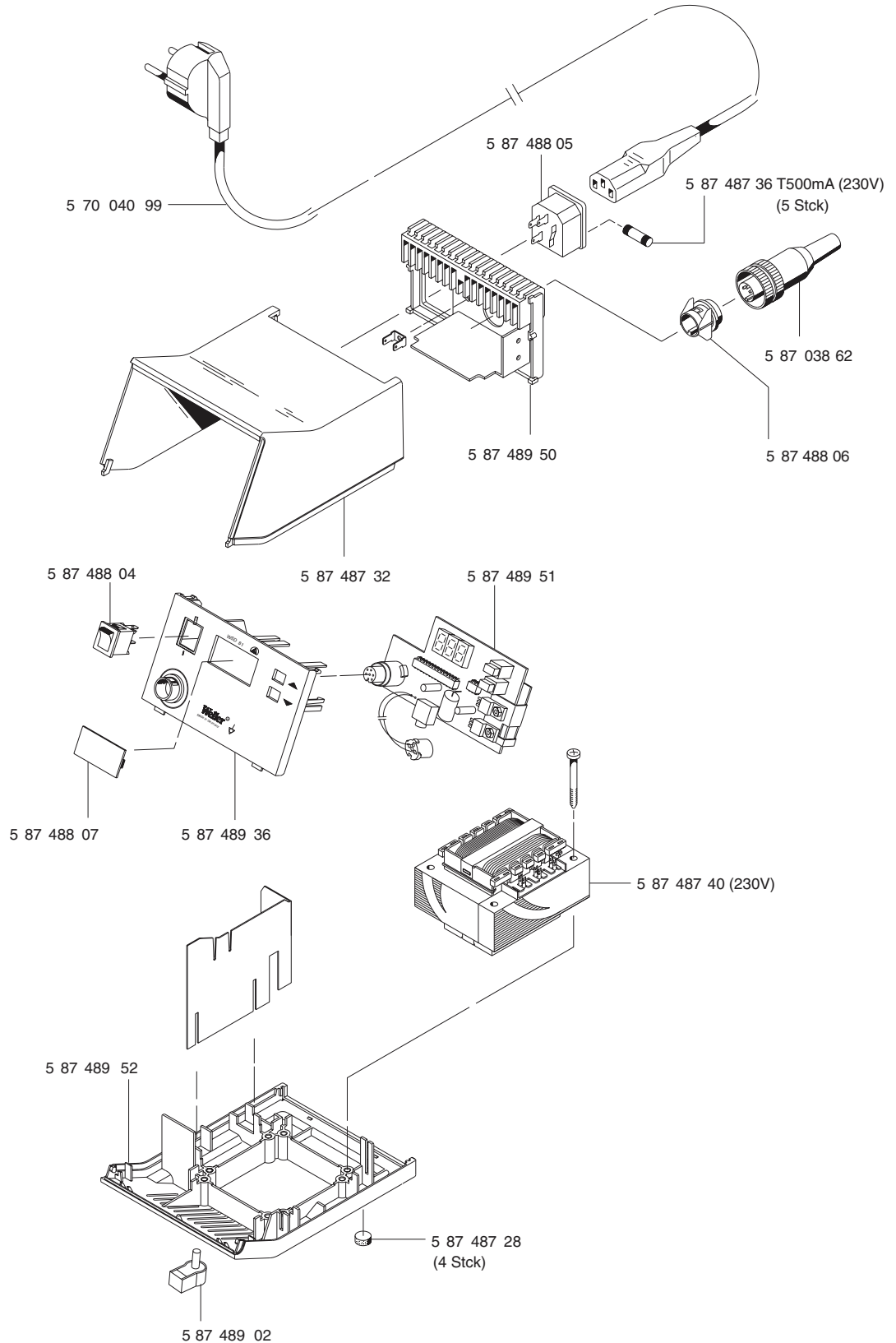

4D9R733

Pyropen + Pyropen Piezo

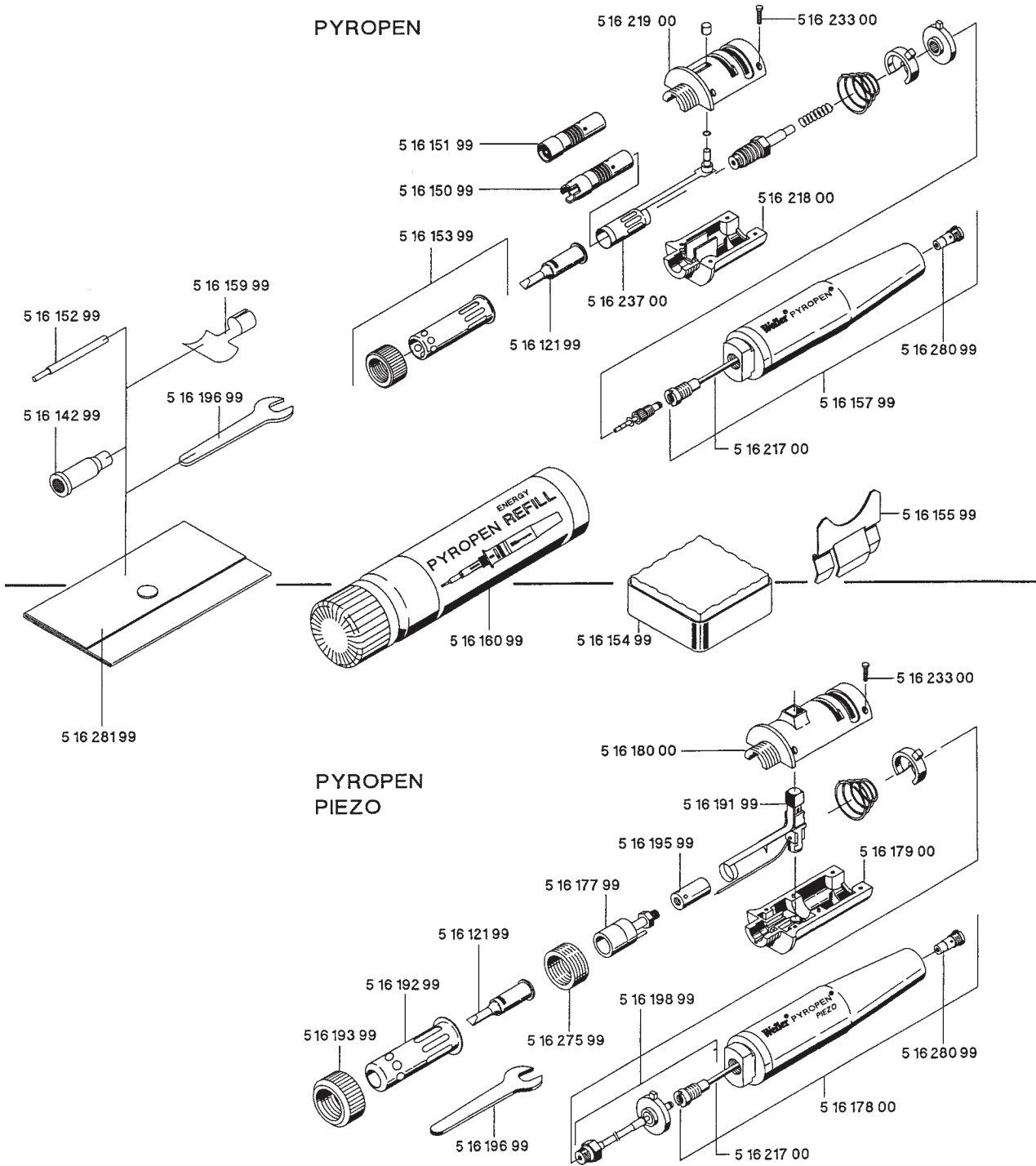

4D2R210/4

4D2R210/4
06.10.01 / Martin

Pyropen JR.

Weller®

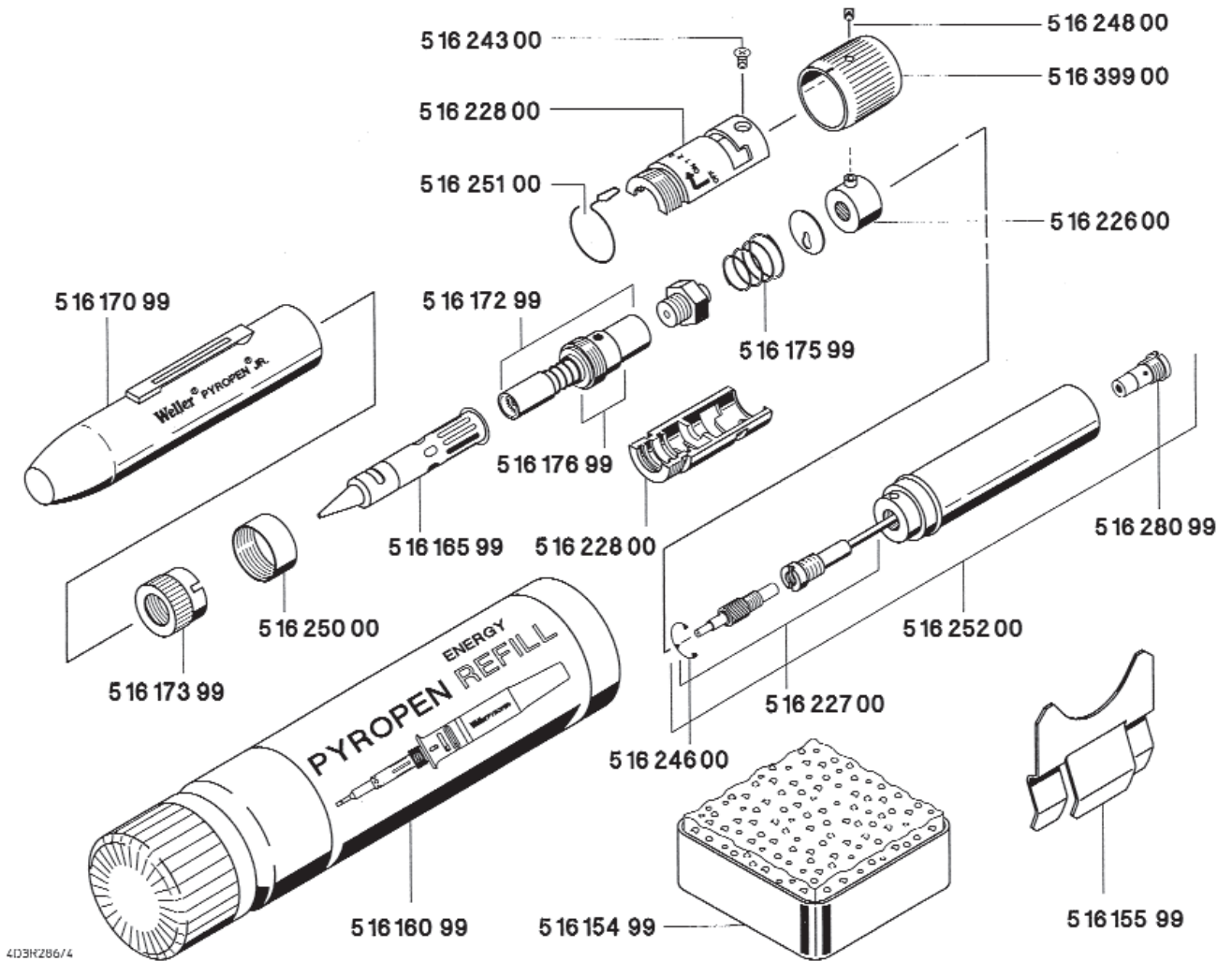

4D3KZ86/4

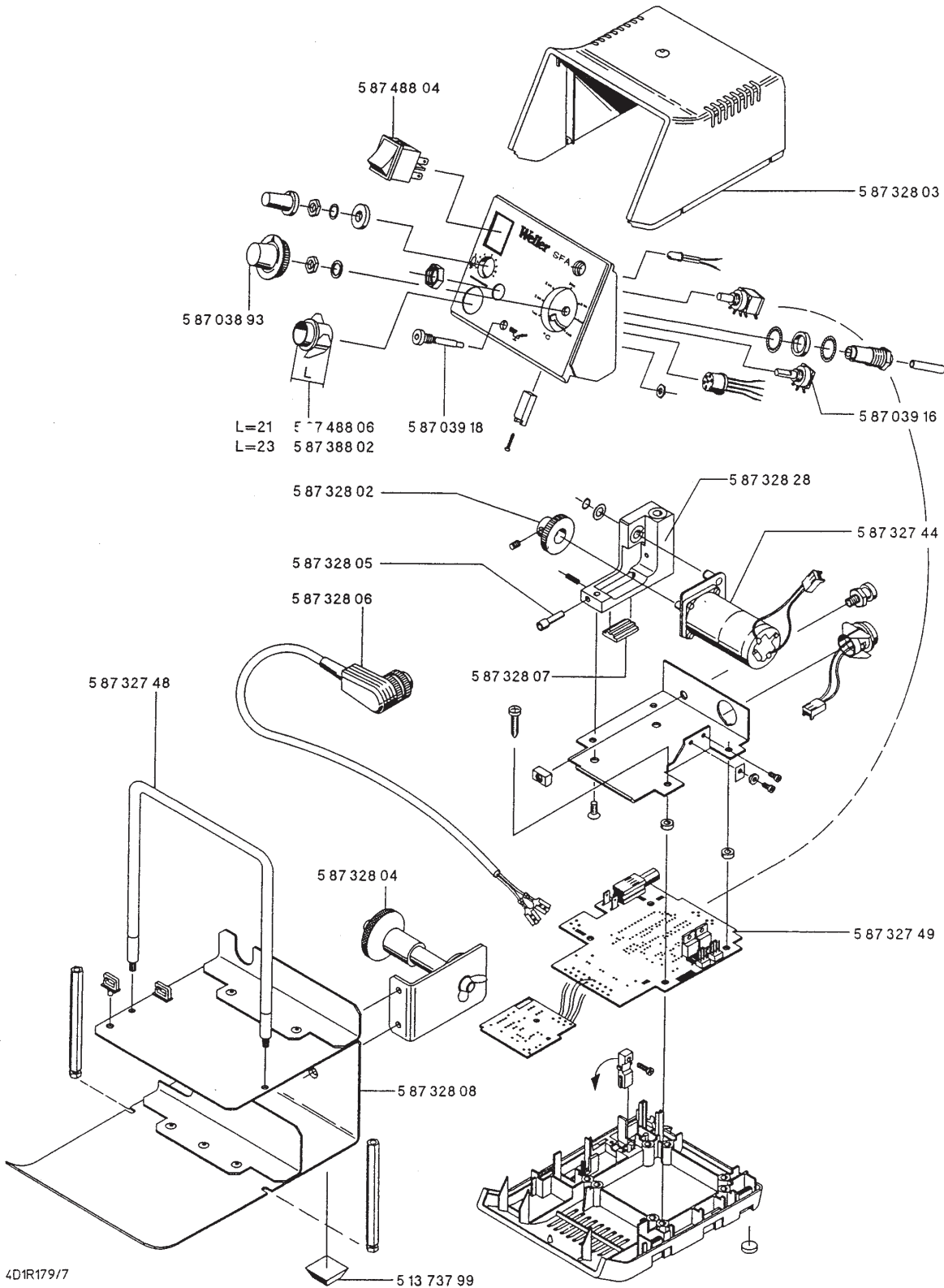

4D1R179/7

SFA / SFC

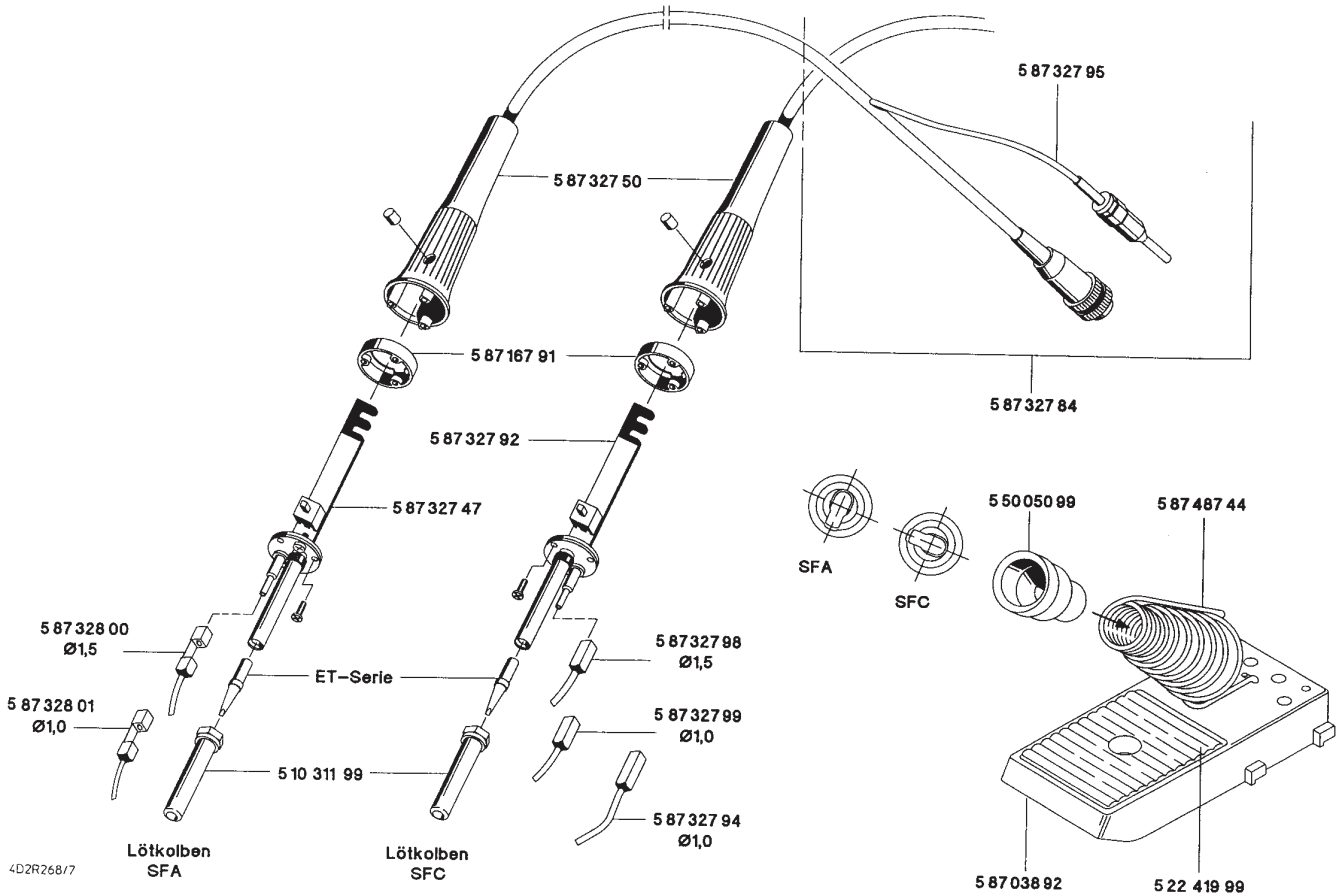

WAD 100



- USA 5 70 048 99
- DK 5 70 073 99
- I 5 70 043 99
- CH 5 70 072 99
- GB 5 70 070 99
- F 5 70 040 99
- D 5 70 040 99

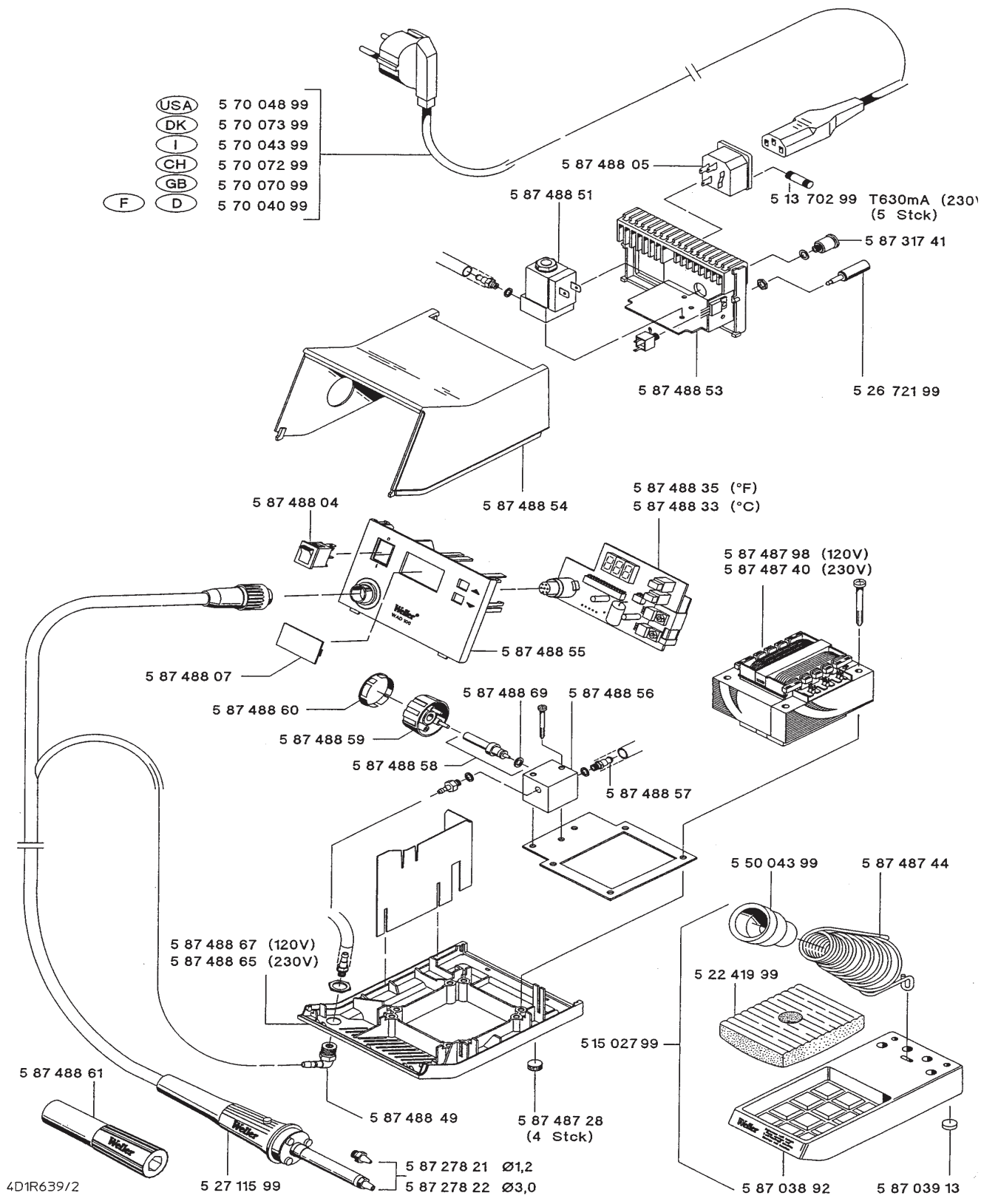

WAD 101

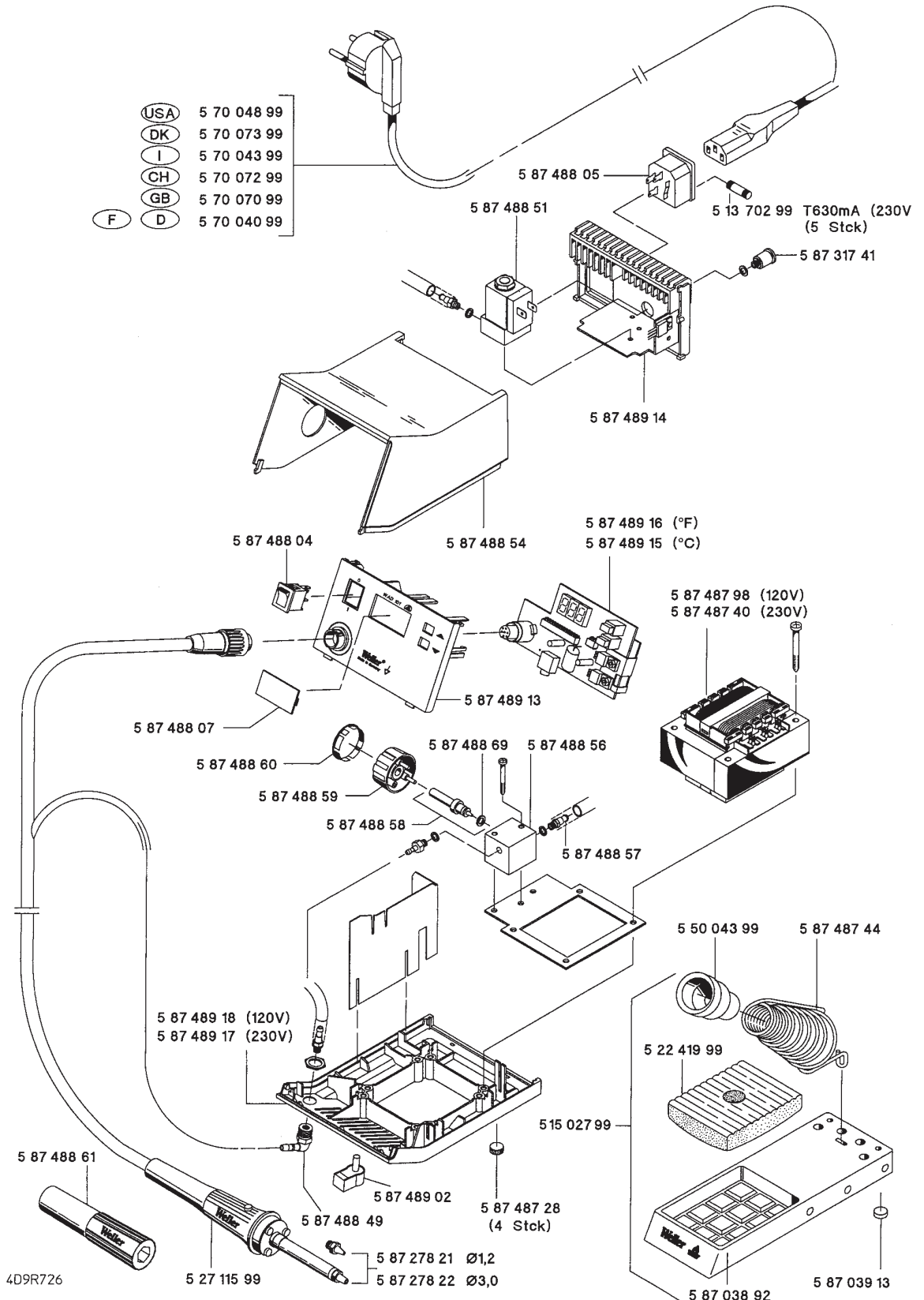

WDD 80V

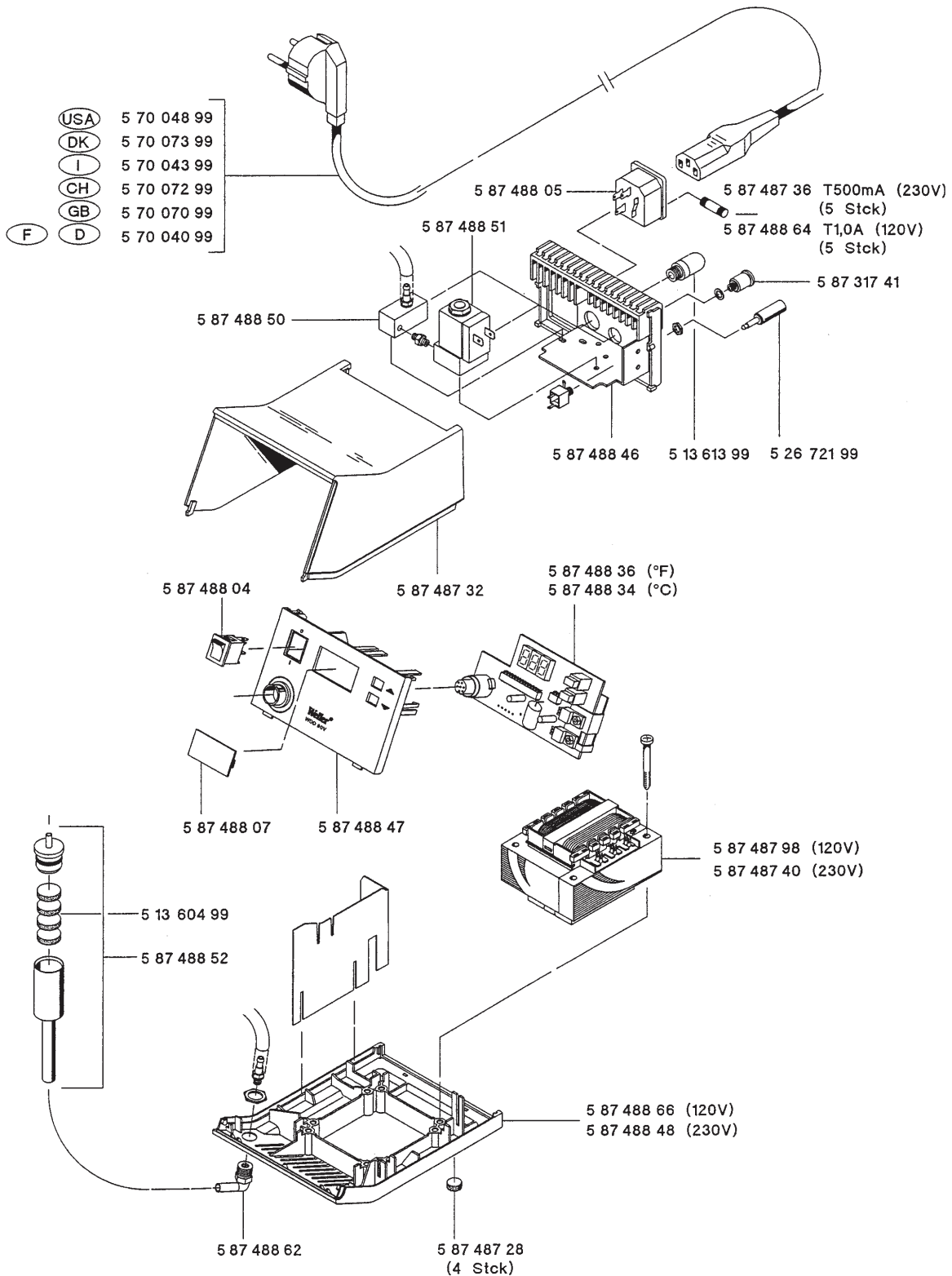

4D1R638/2

WDD 81V

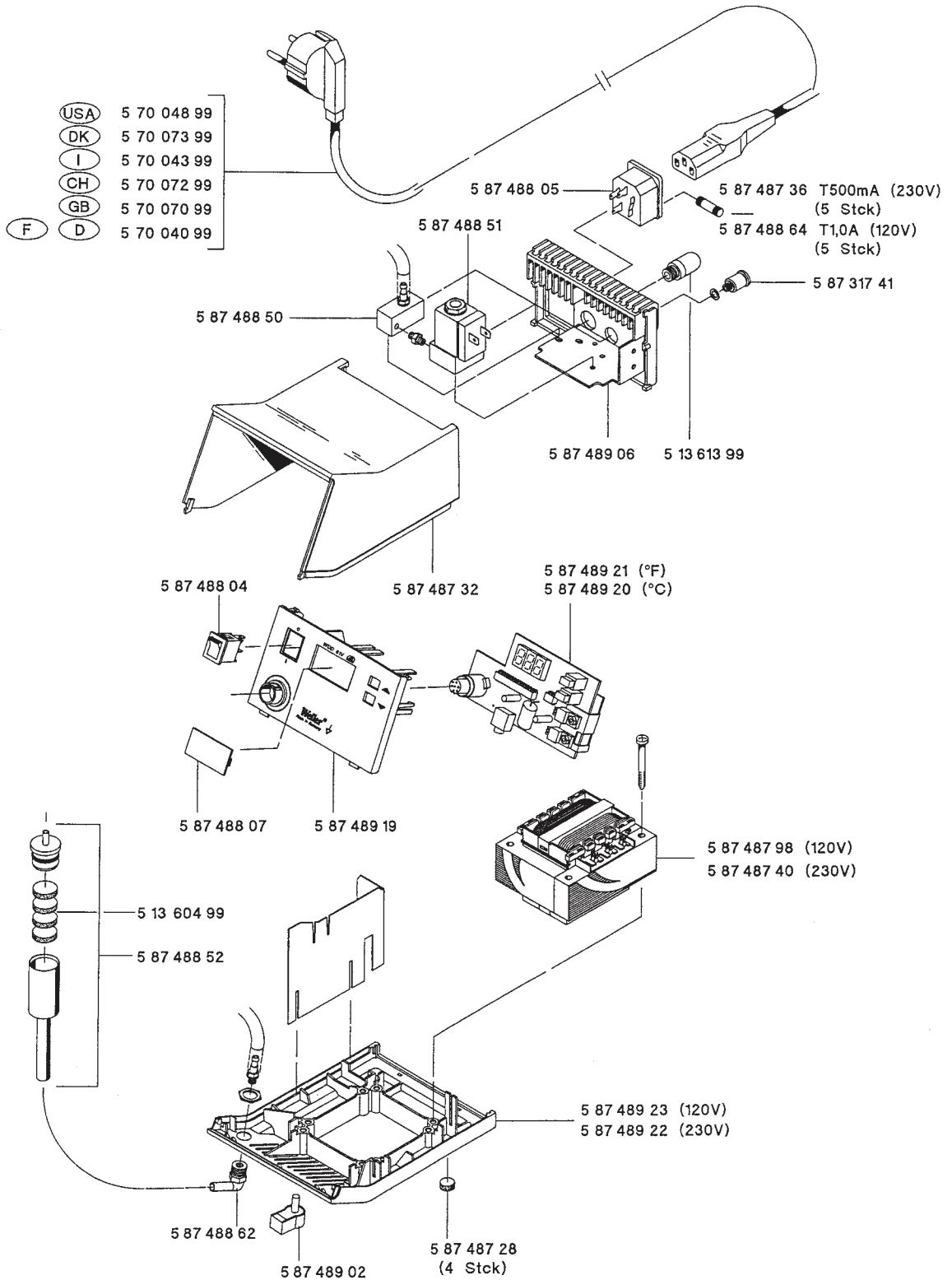

4D9R725

WDD 161V

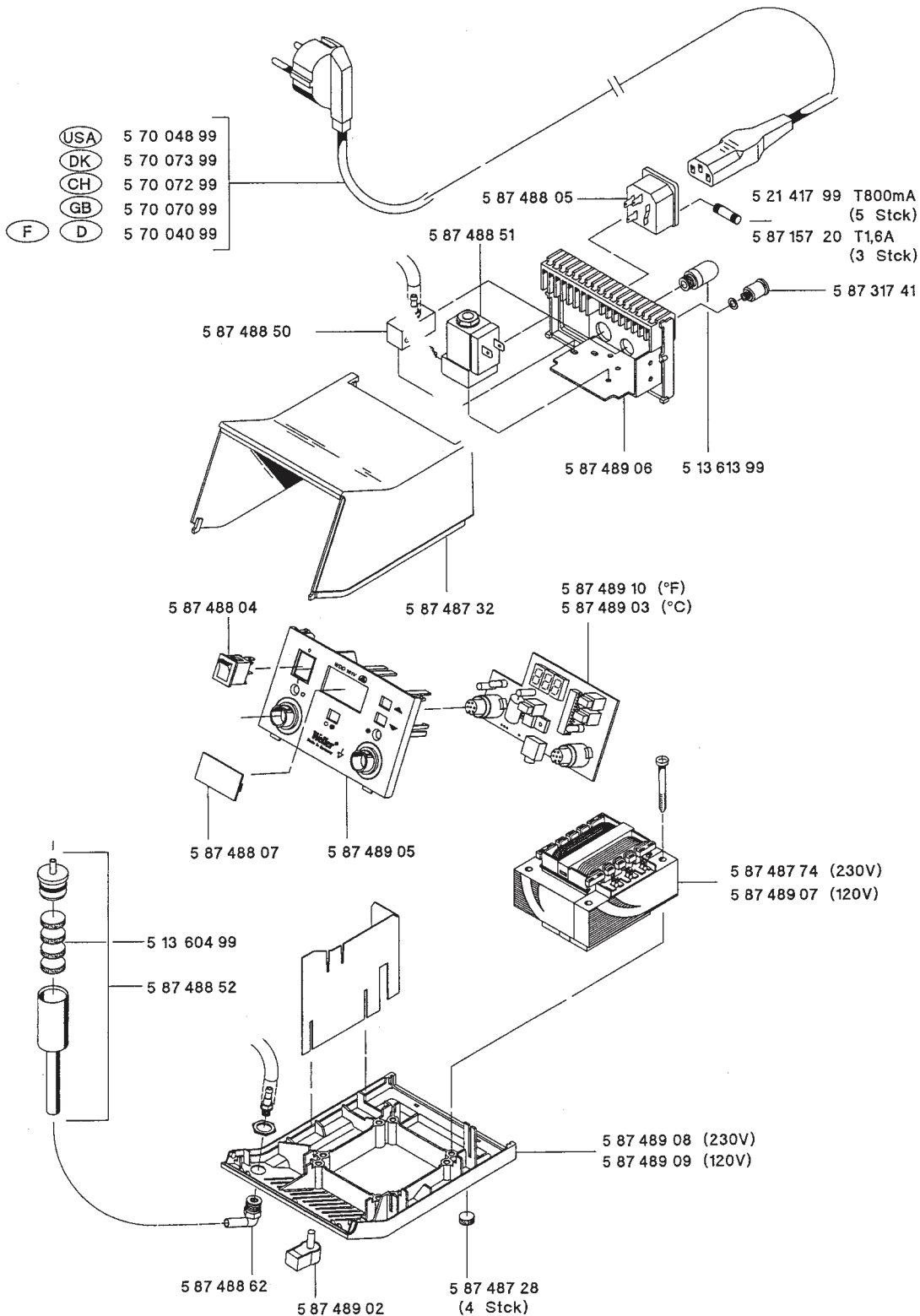

4D9R722

WFE

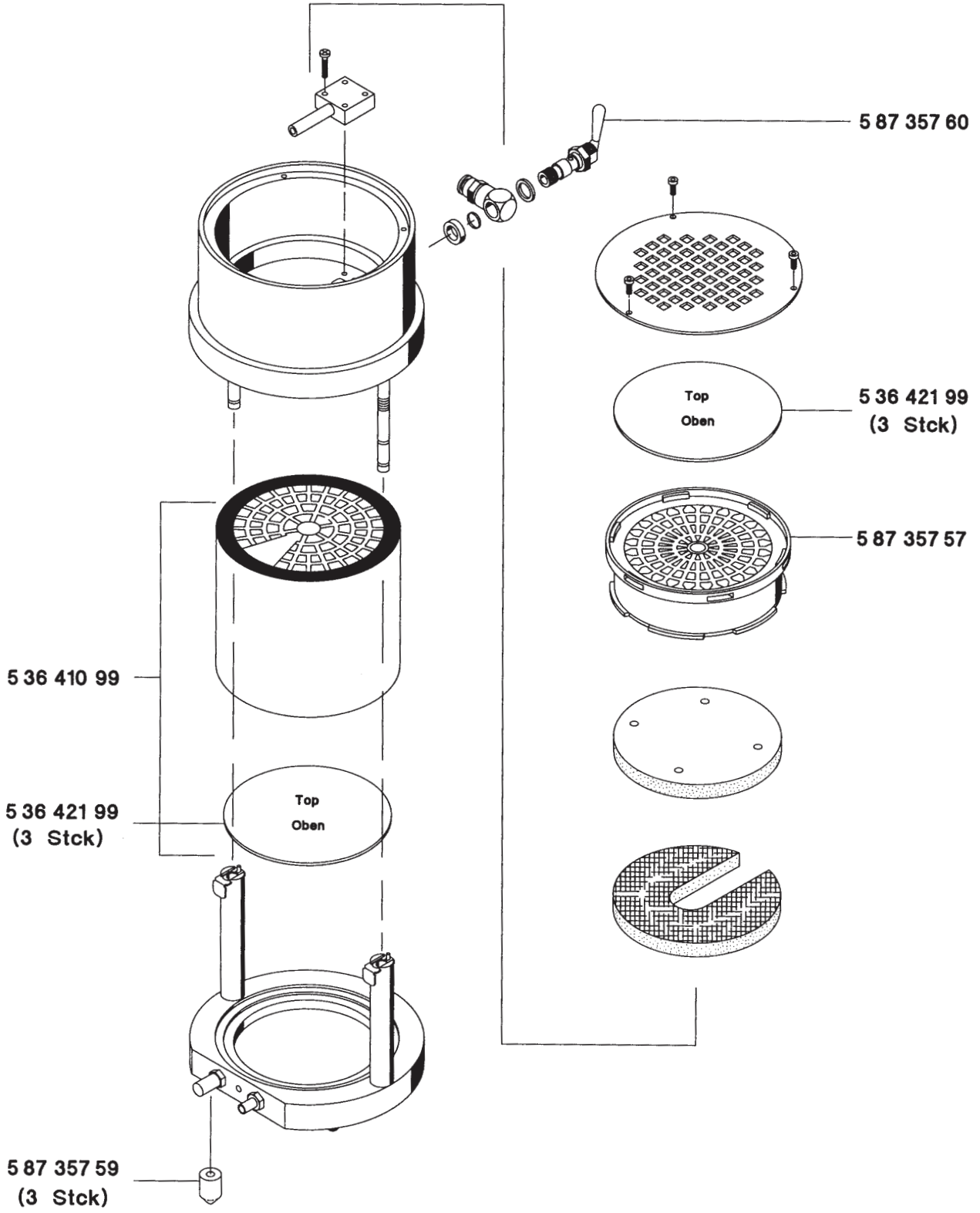

4D2R504/2

WFE 2S

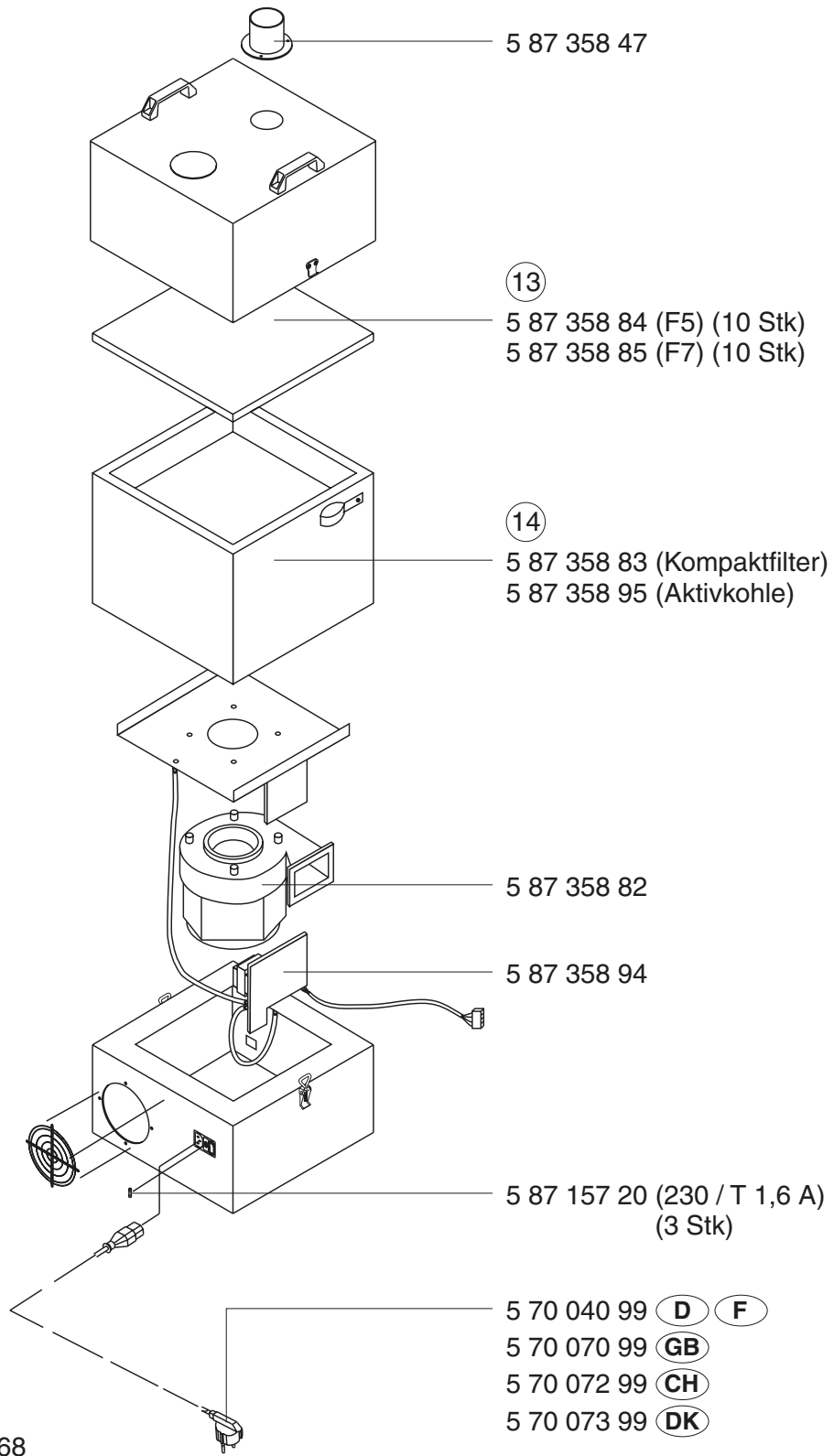

WFE 35

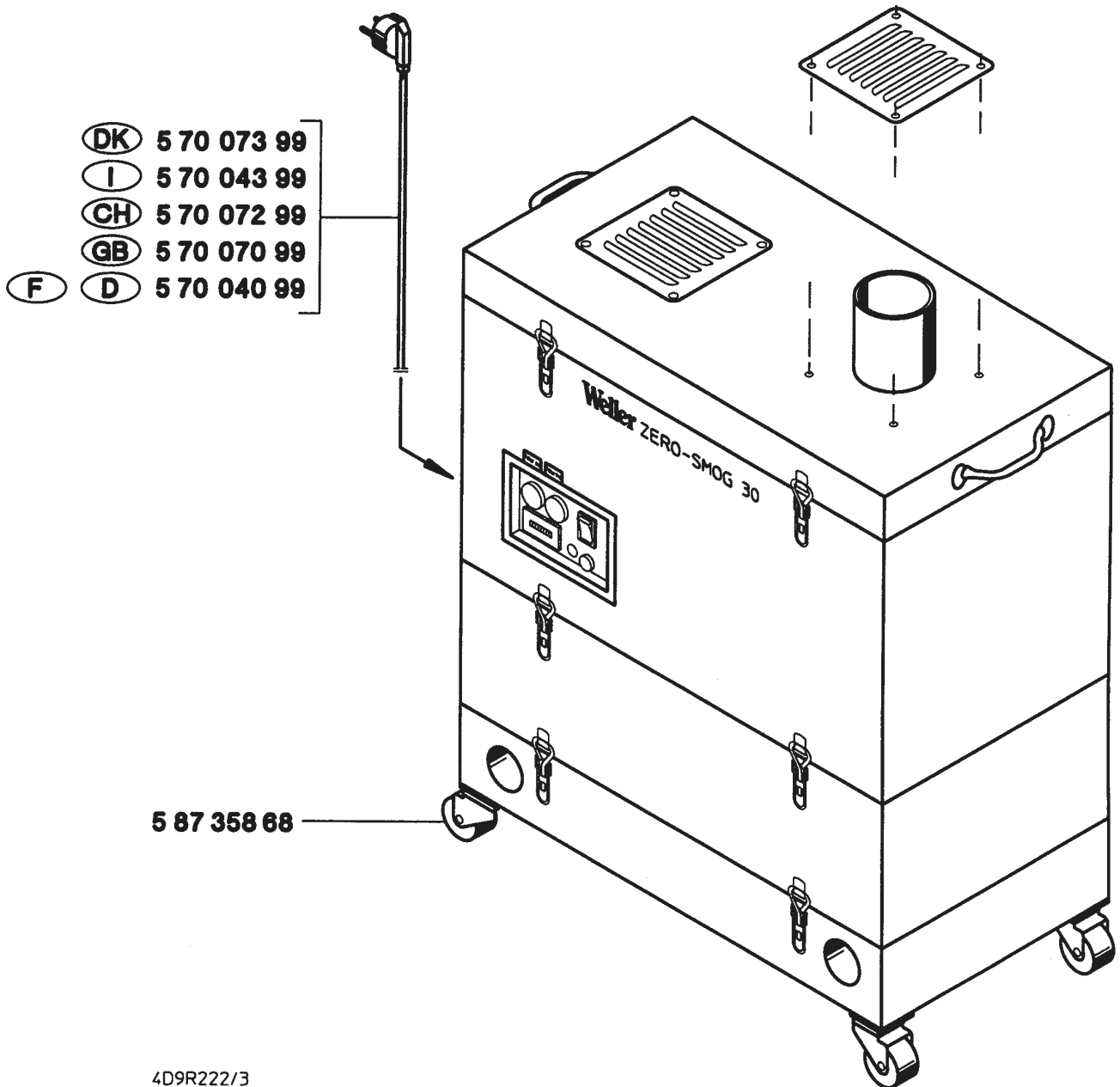

4D9R222/3

WFE 4S

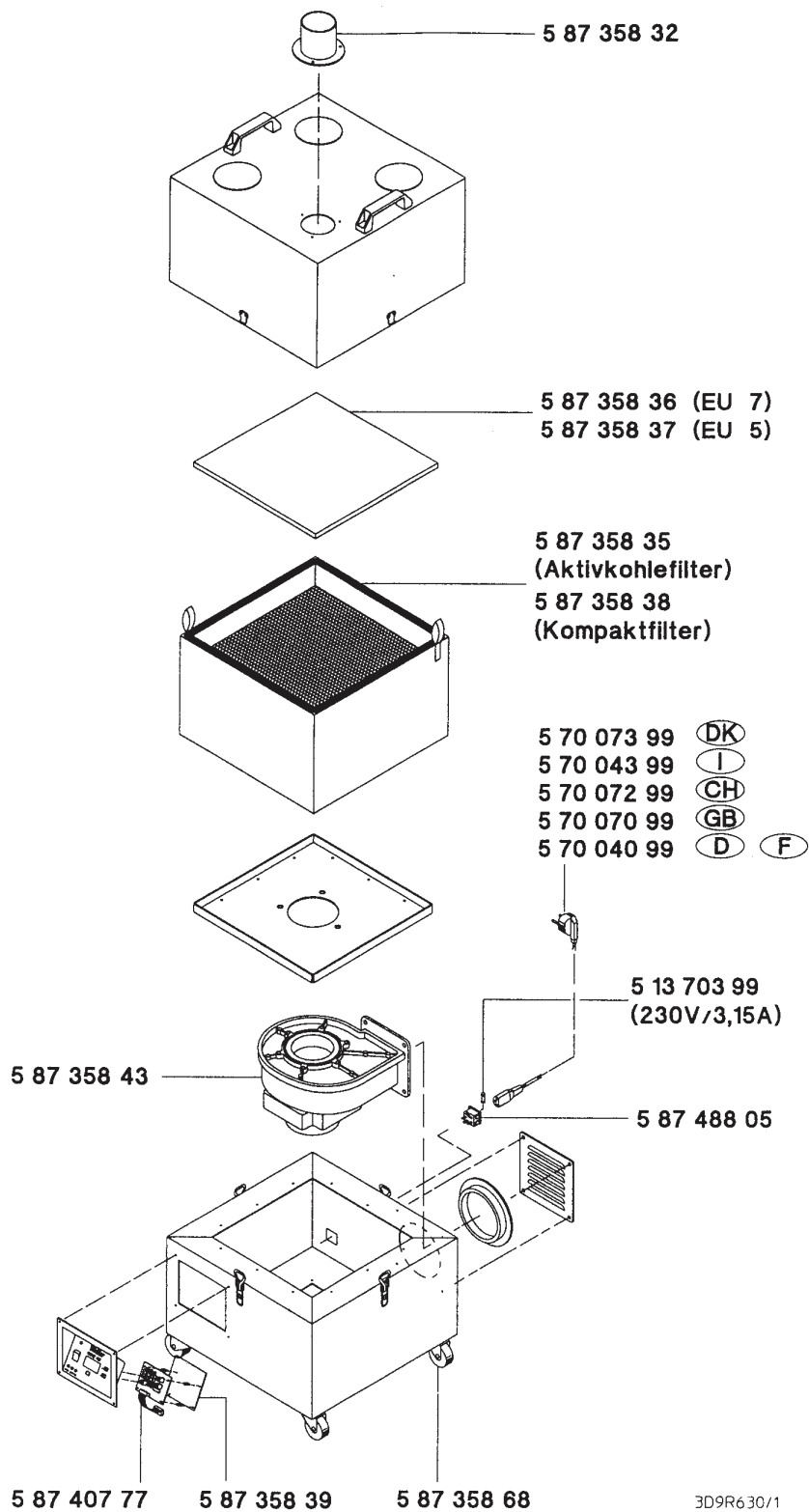

WFE P(2)

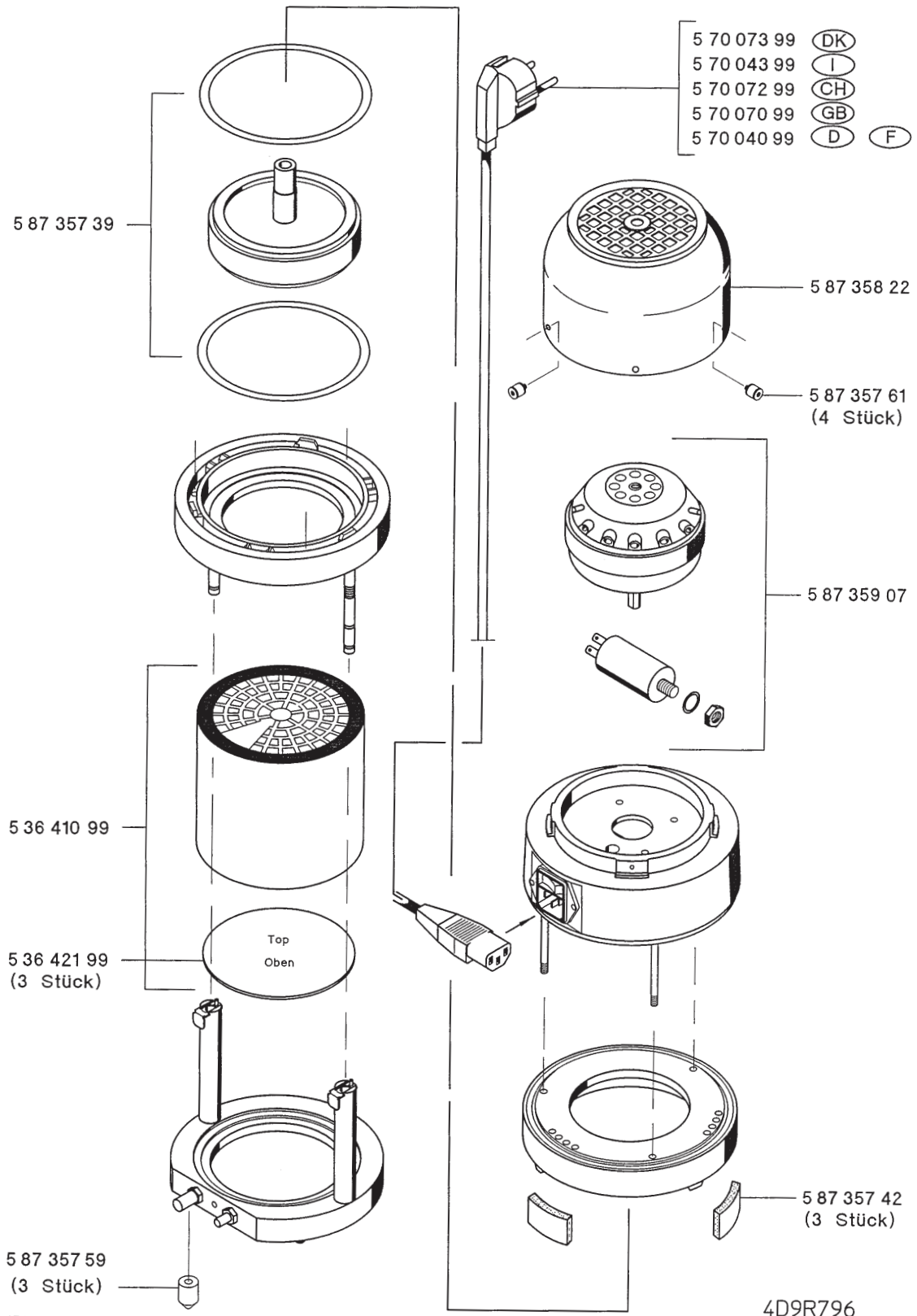

4D9R796
29.01.03/eis.

WFE P

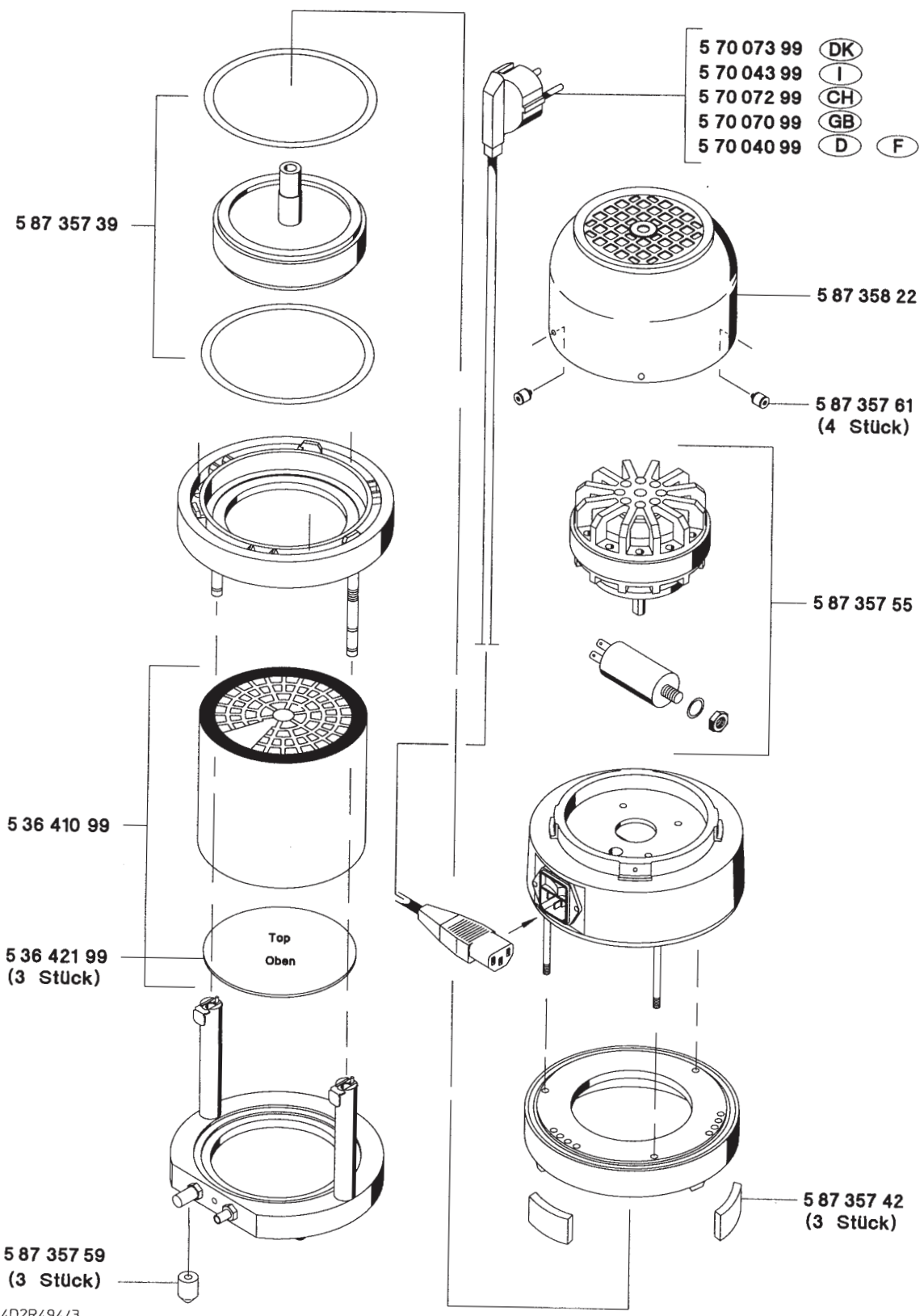

4D2R494/3

WHA 300

Weller®

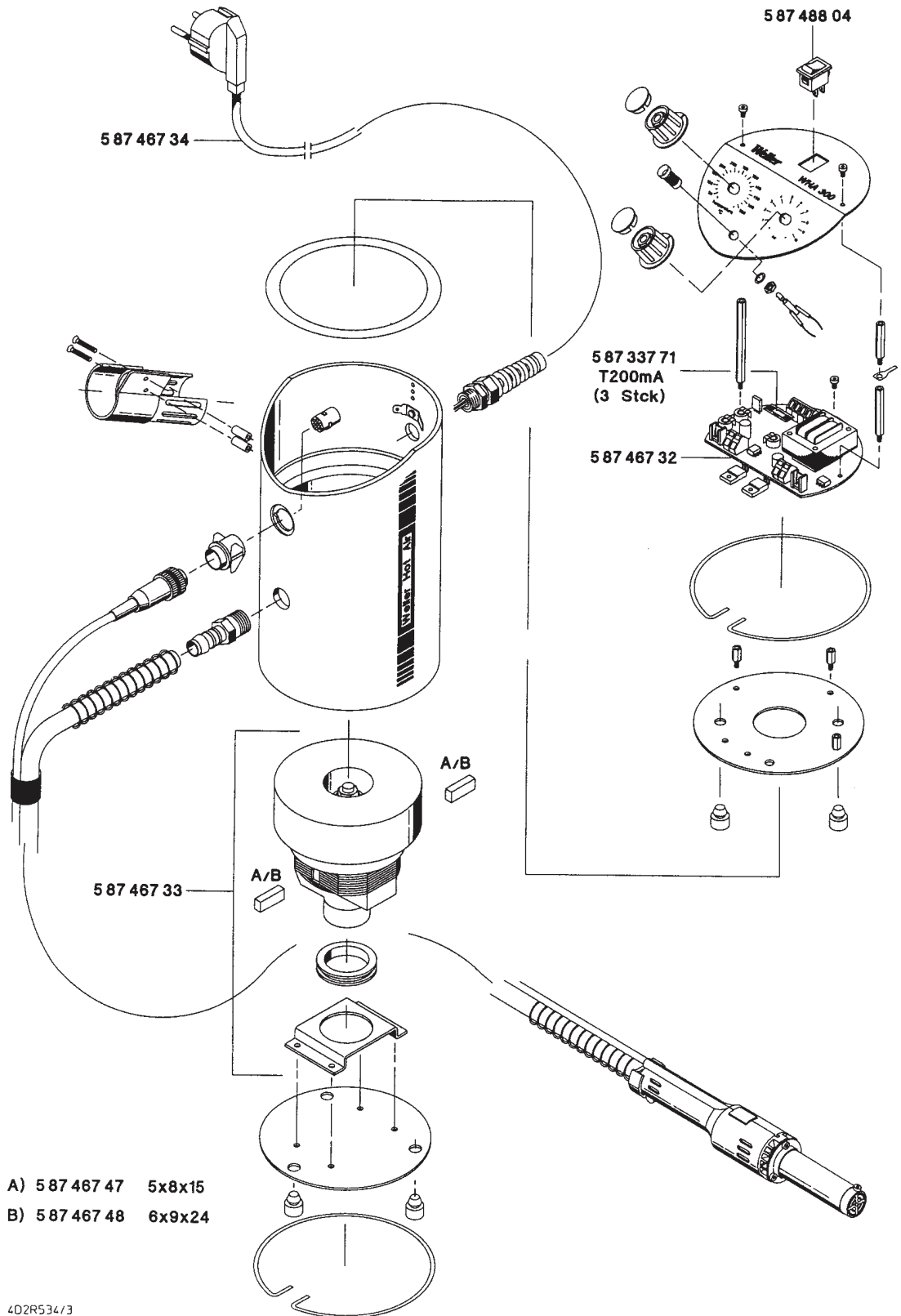

402R534/3

WHA 700

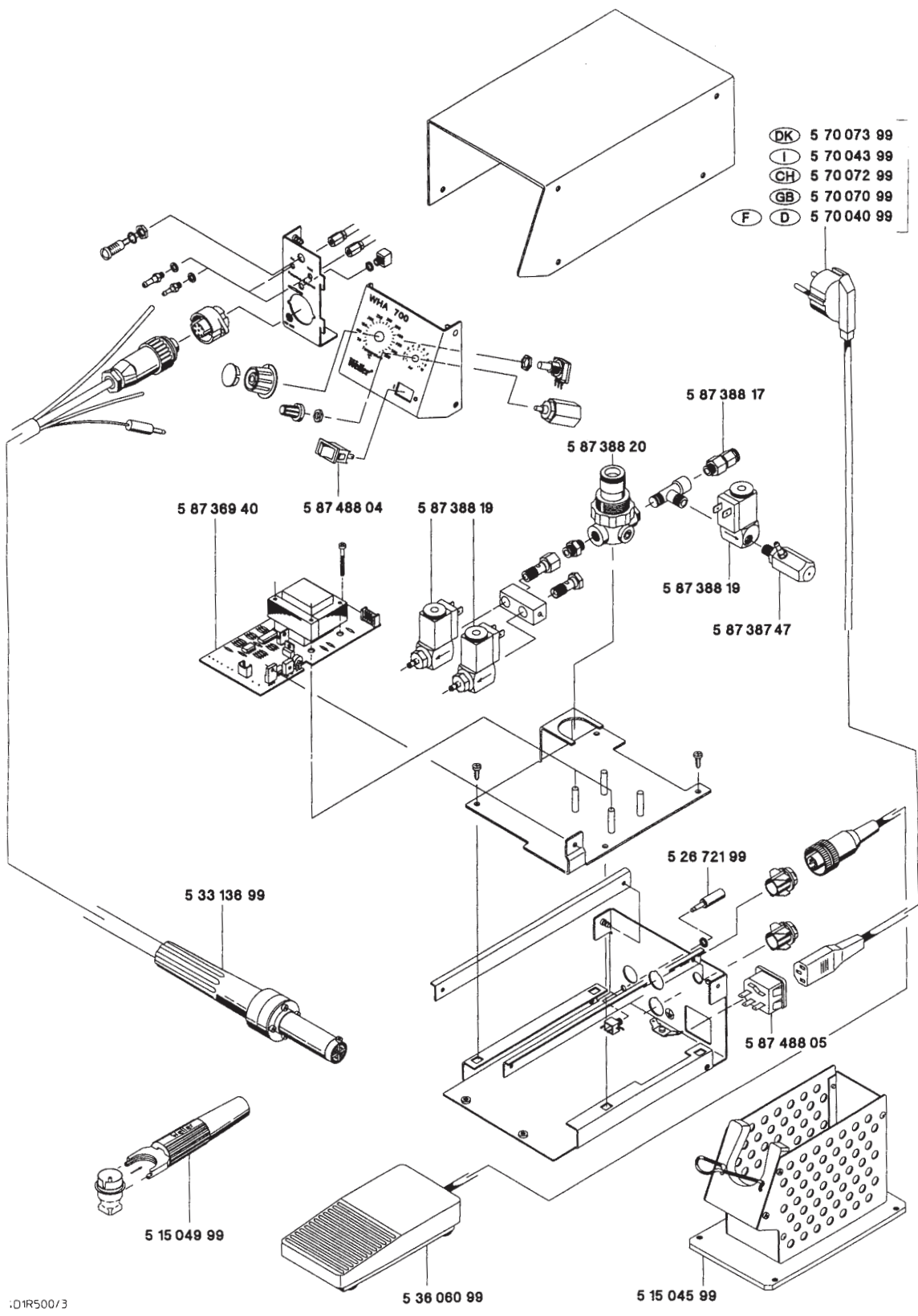

:DIR500/3

WHA 2000

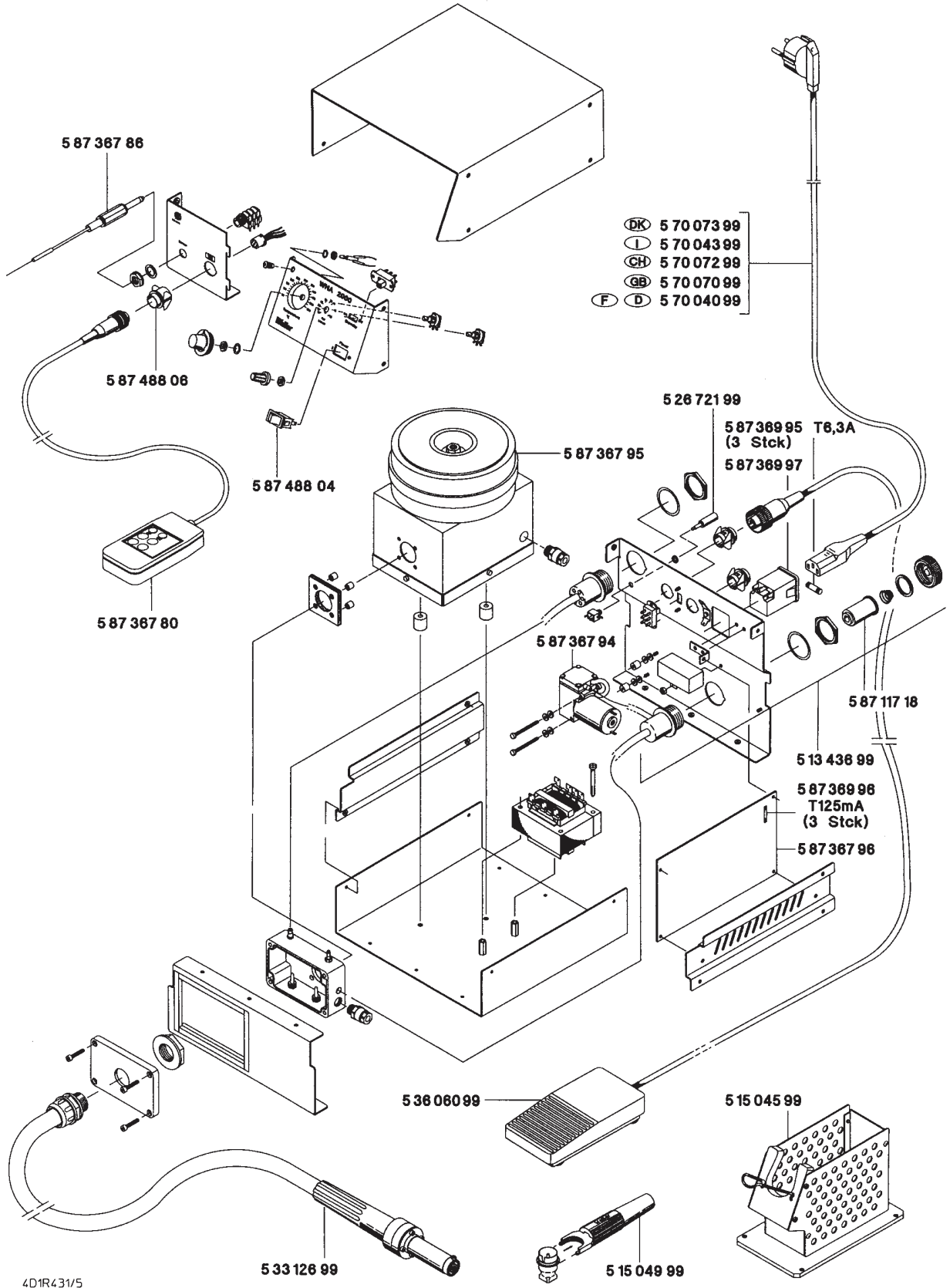

WHP 300

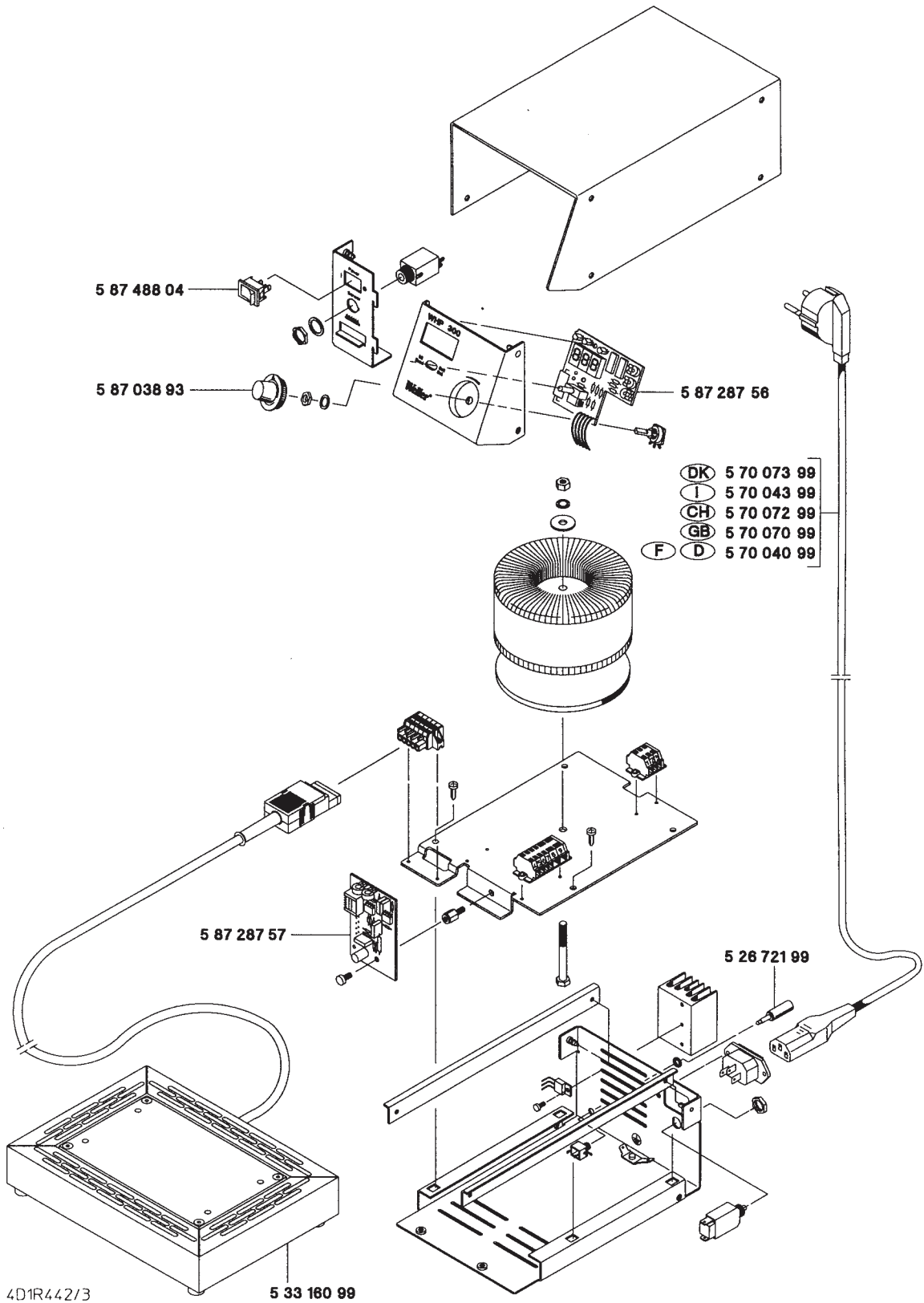

WMA 3V

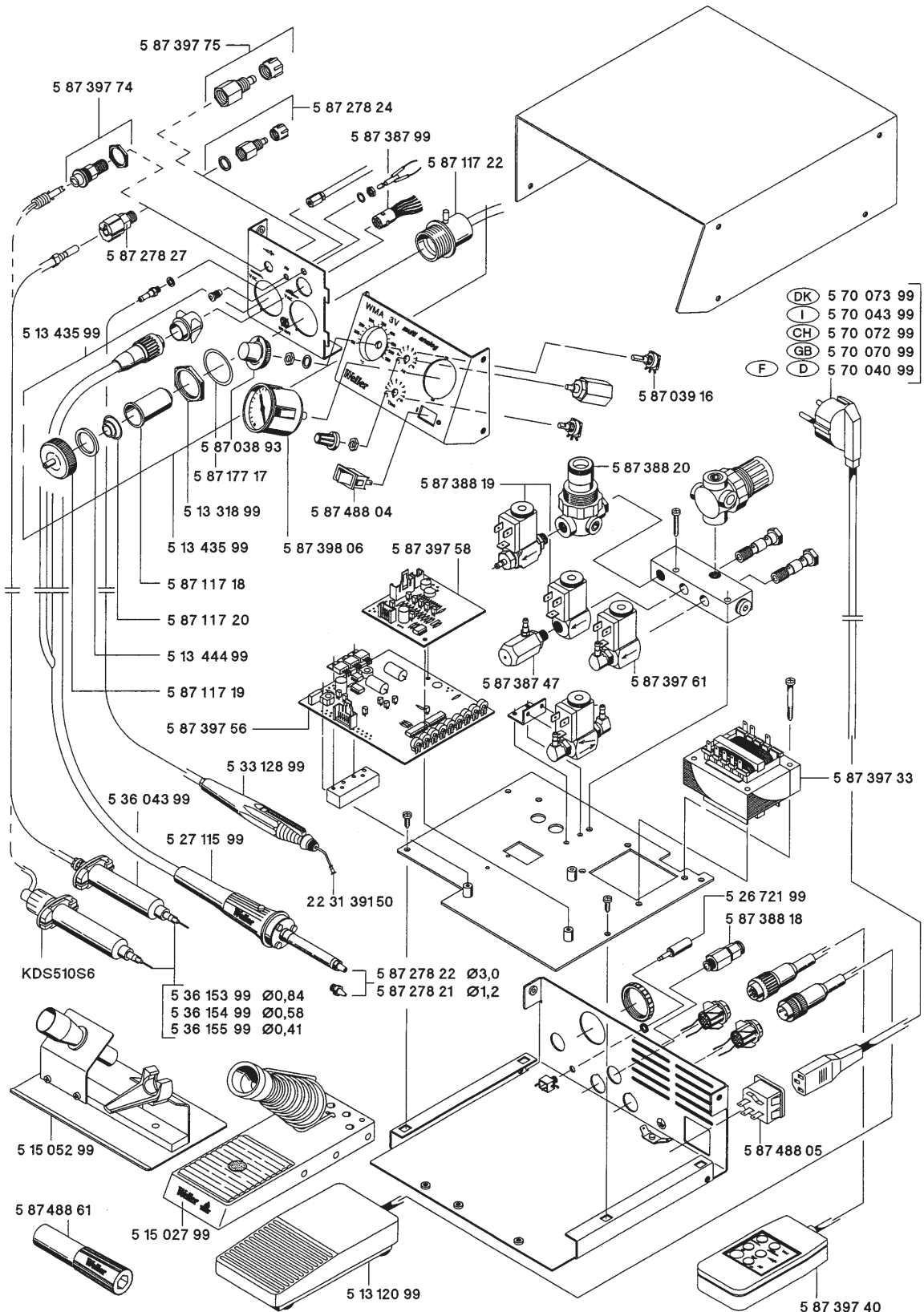

4D1R467/9

WMD 1

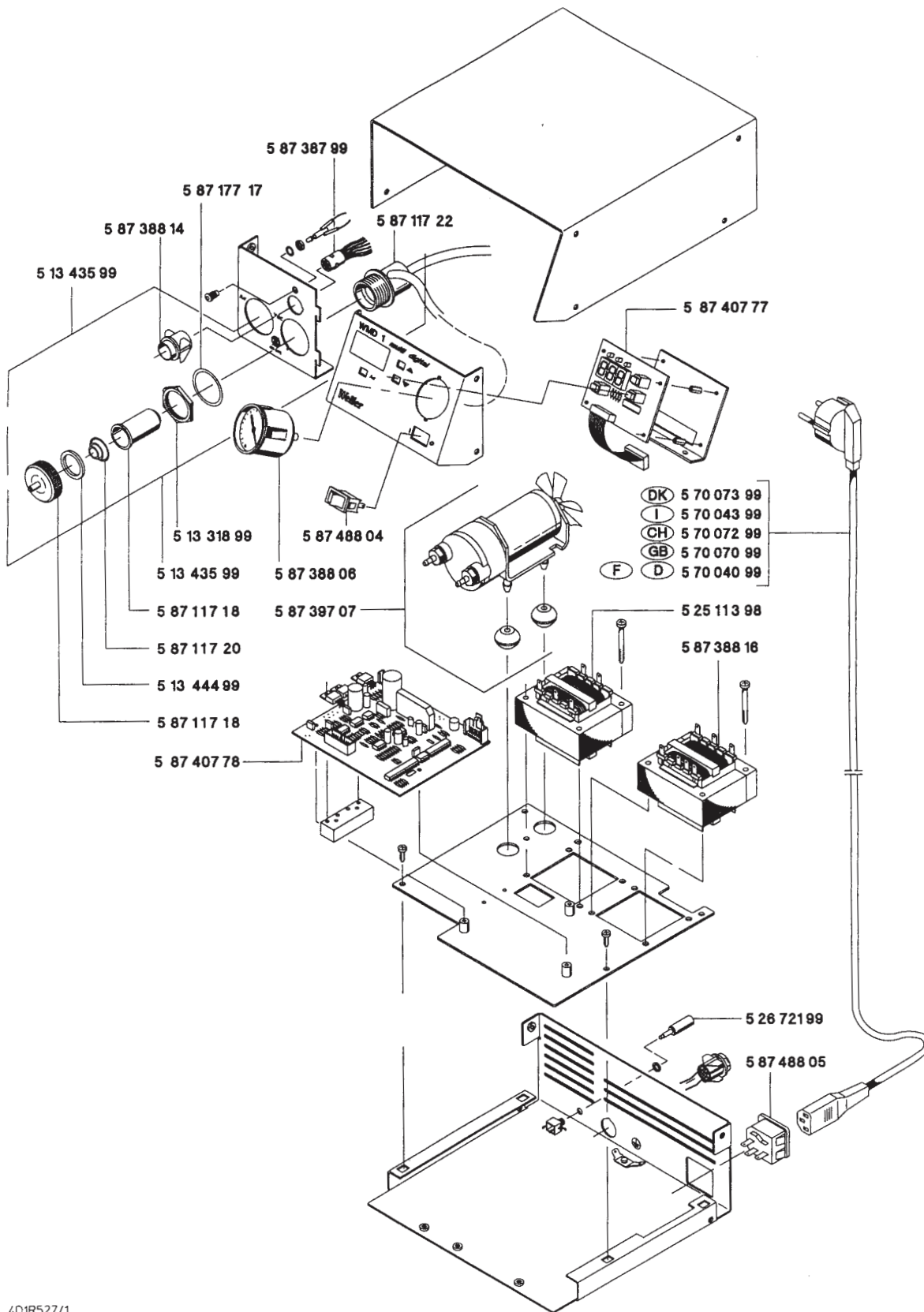

4D1R527/1

WMD 1S

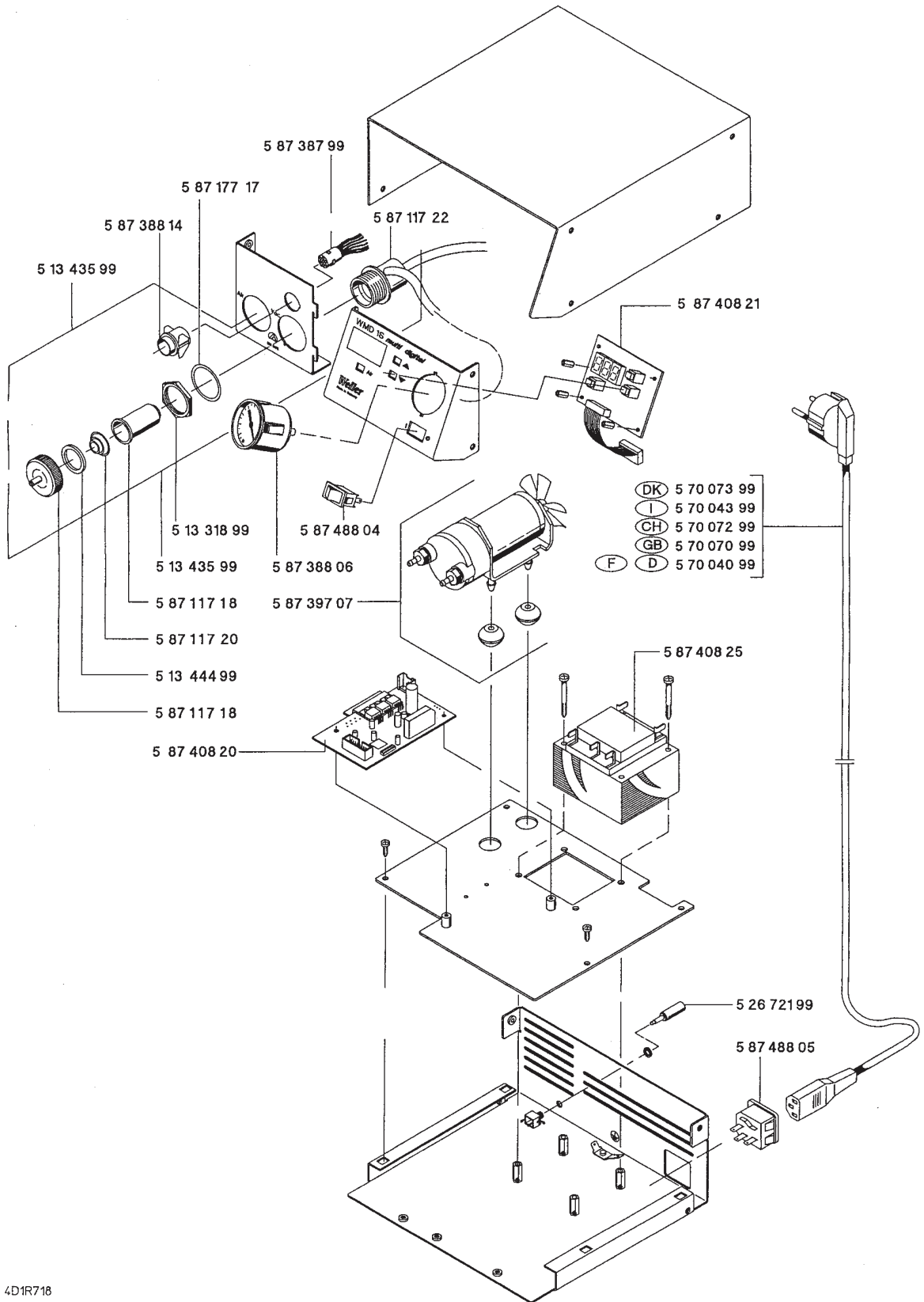

4D1R718

WMD 3

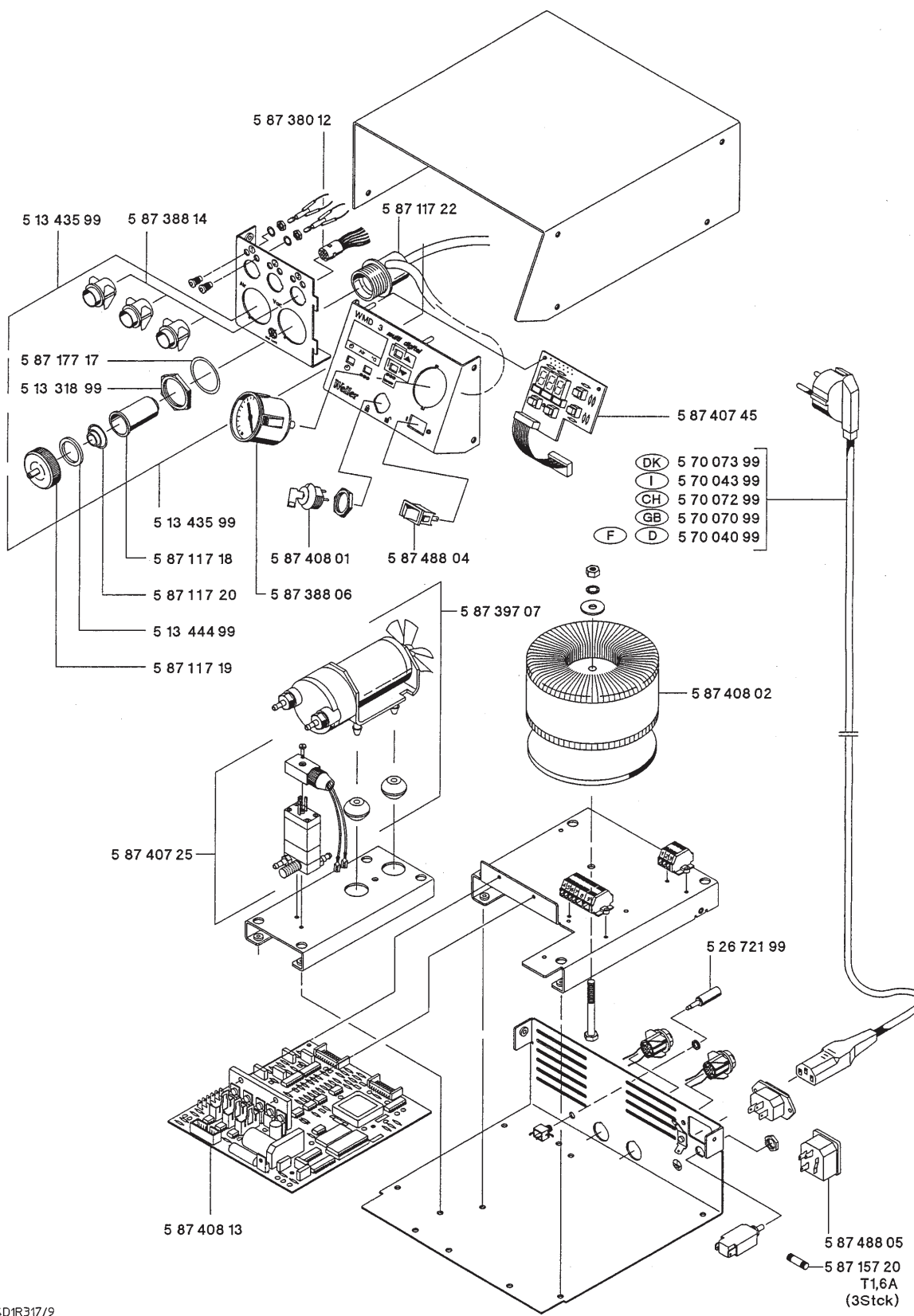

4D1R317/9

WS 50

- DK 5 70 073 99
- I 5 70 043 99
- CH 5 70 072 99
- GB 5 70 070 99
- F D 5 70 040 99

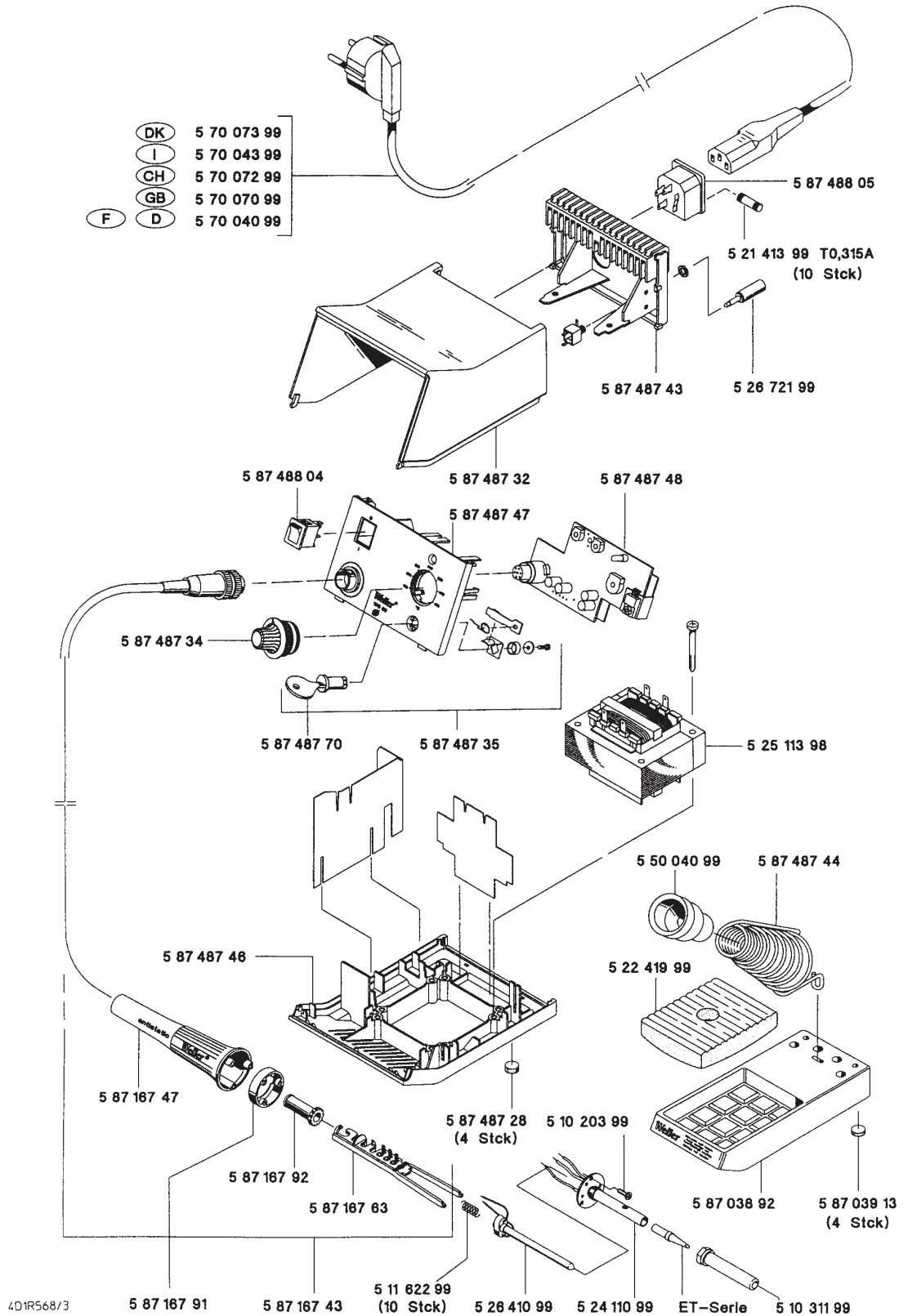

4D1R568/3

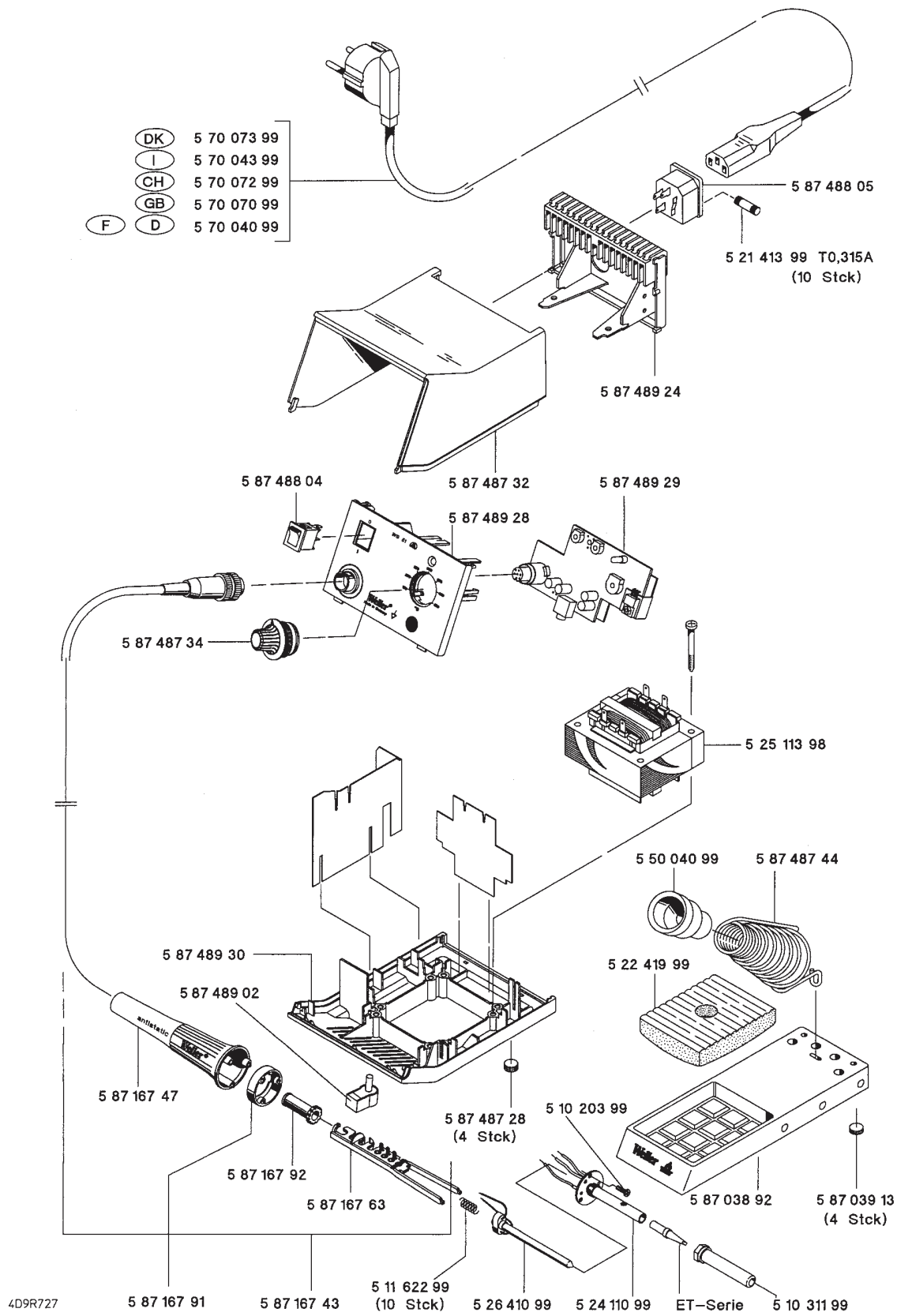

WS 80

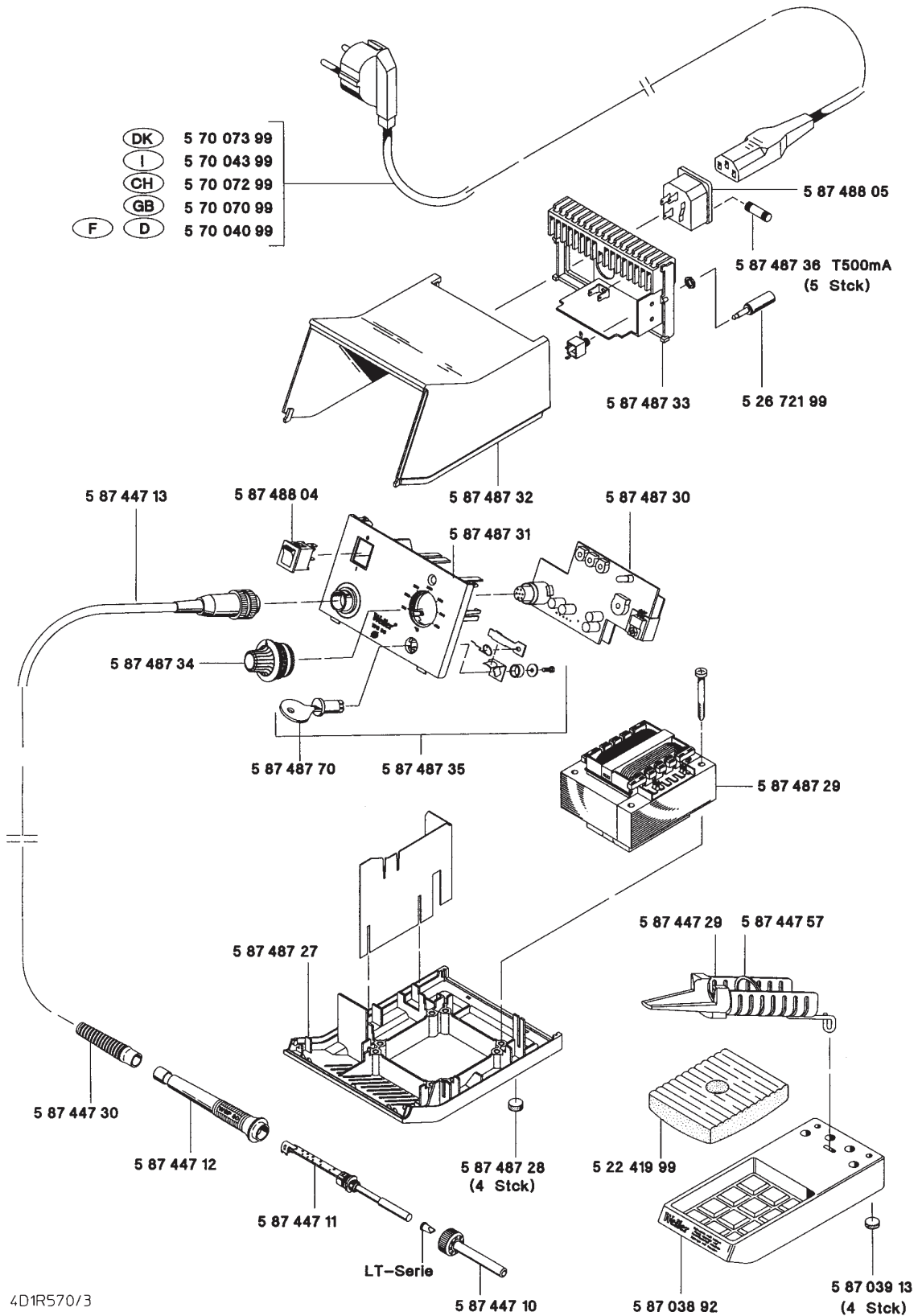

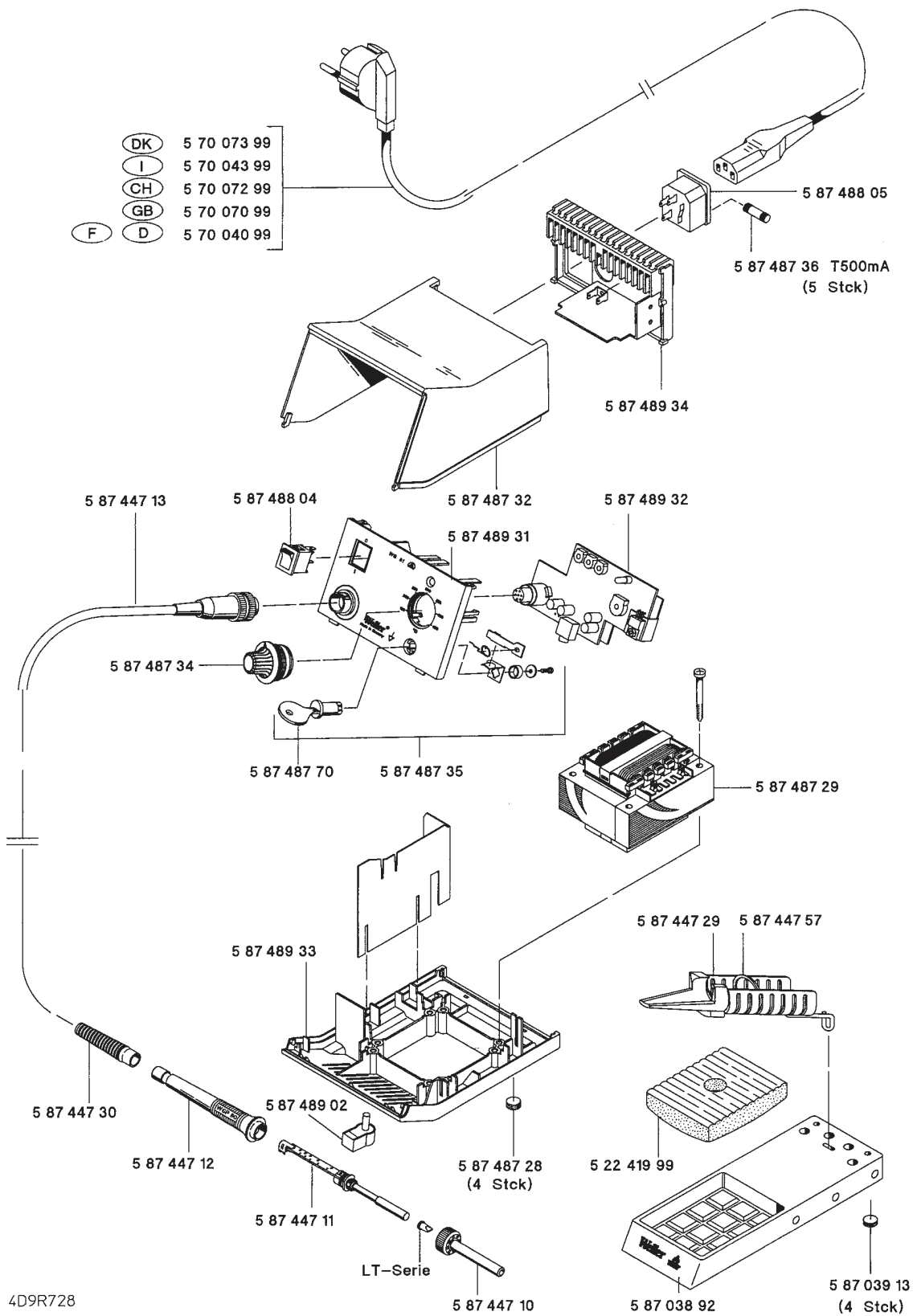

WSA 1

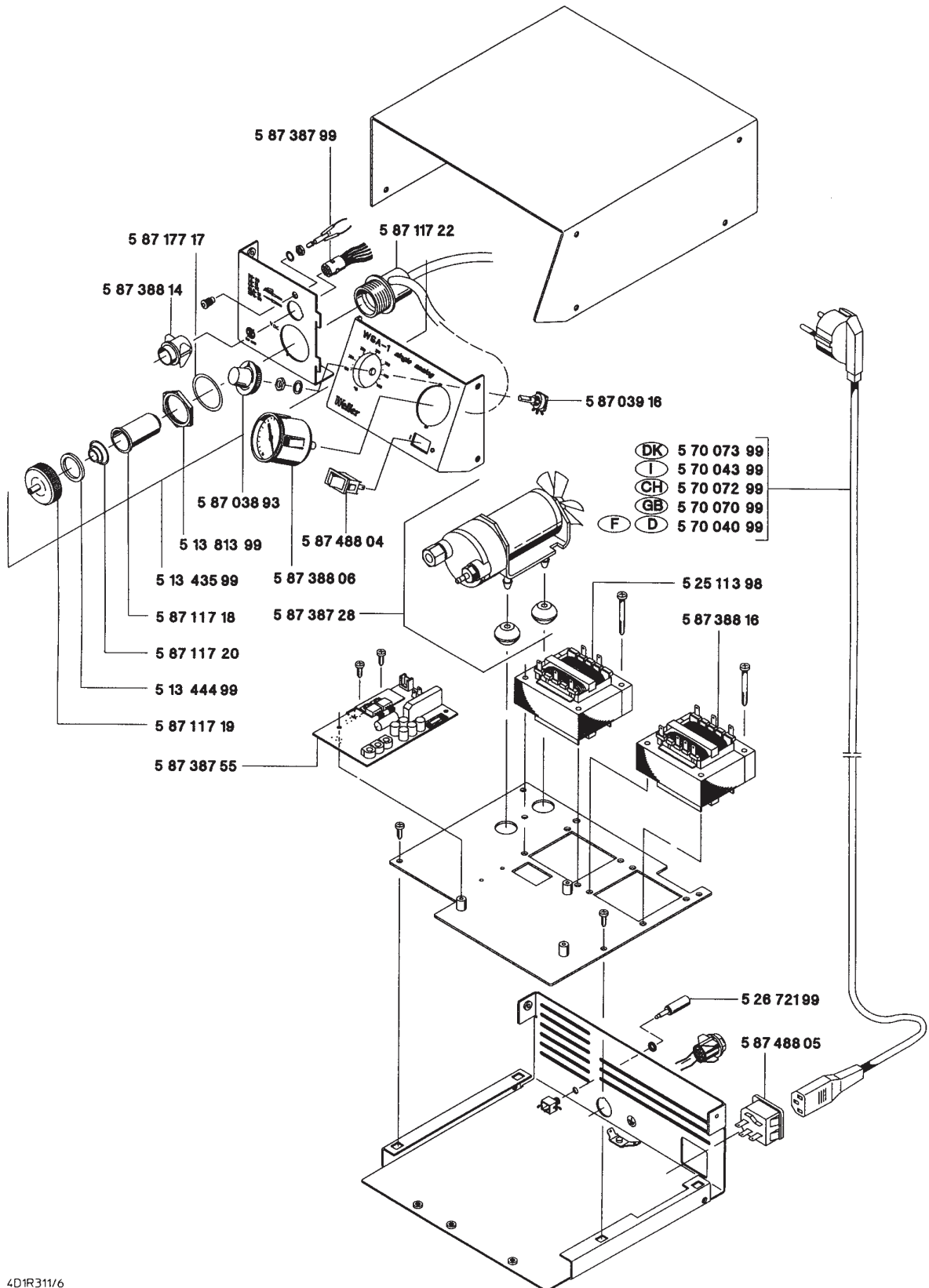

WSA 1R

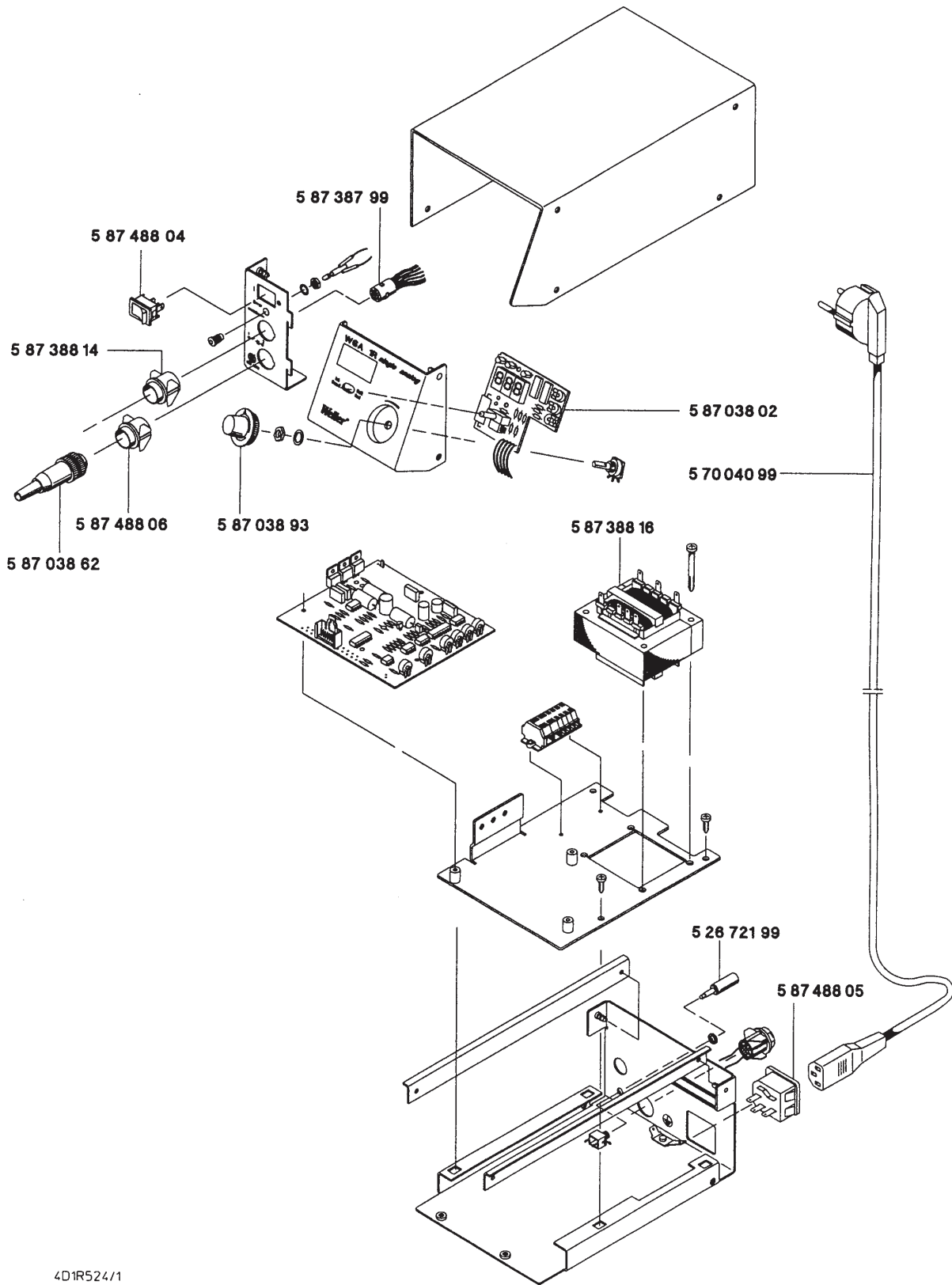

4D1R524/1

WSA 1V

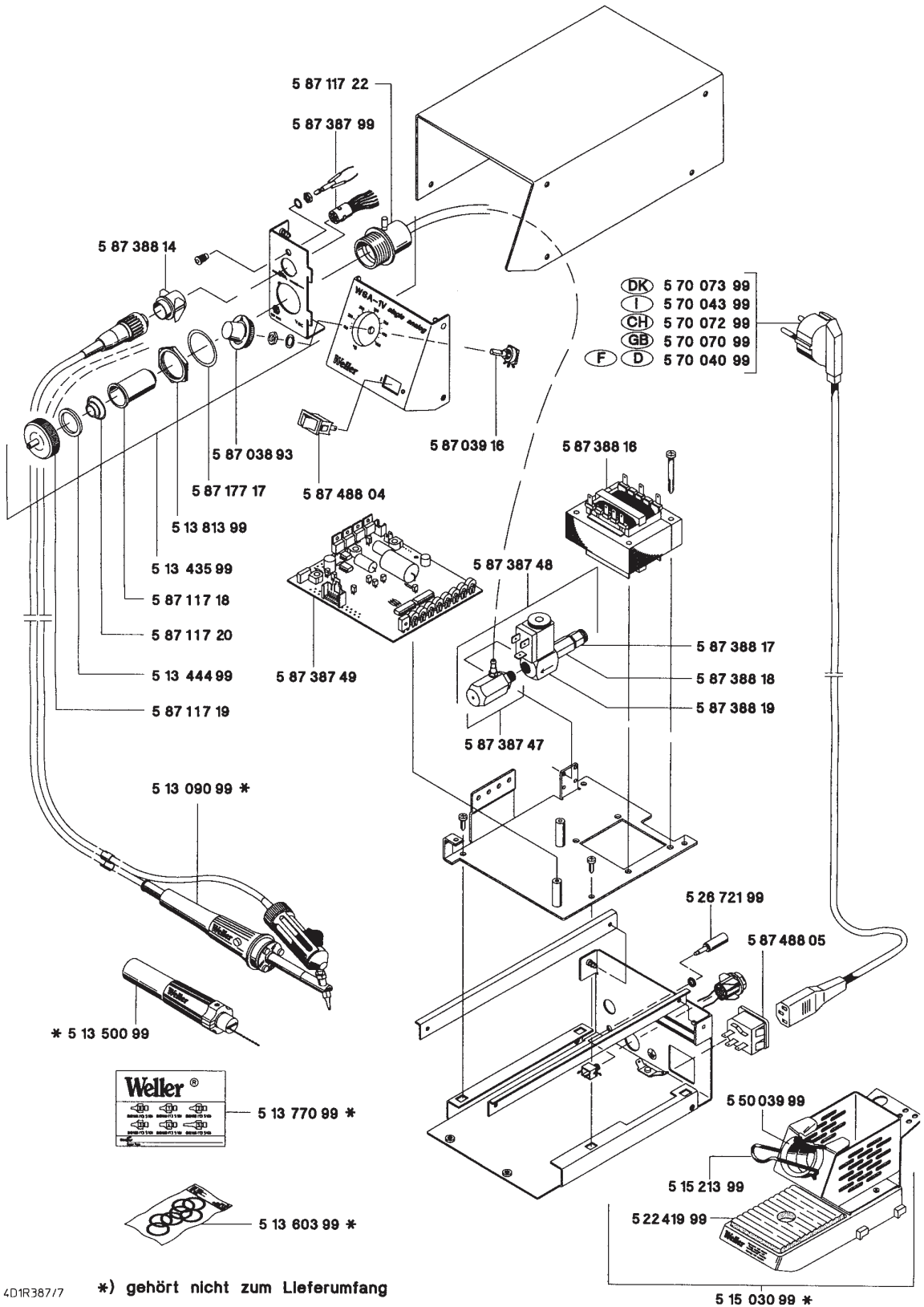

WSD 50



- DK 5 70 073 99
- I 5 70 043 99
- CH 5 70 072 99
- GB 5 70 070 99
- F D 5 70 040 99

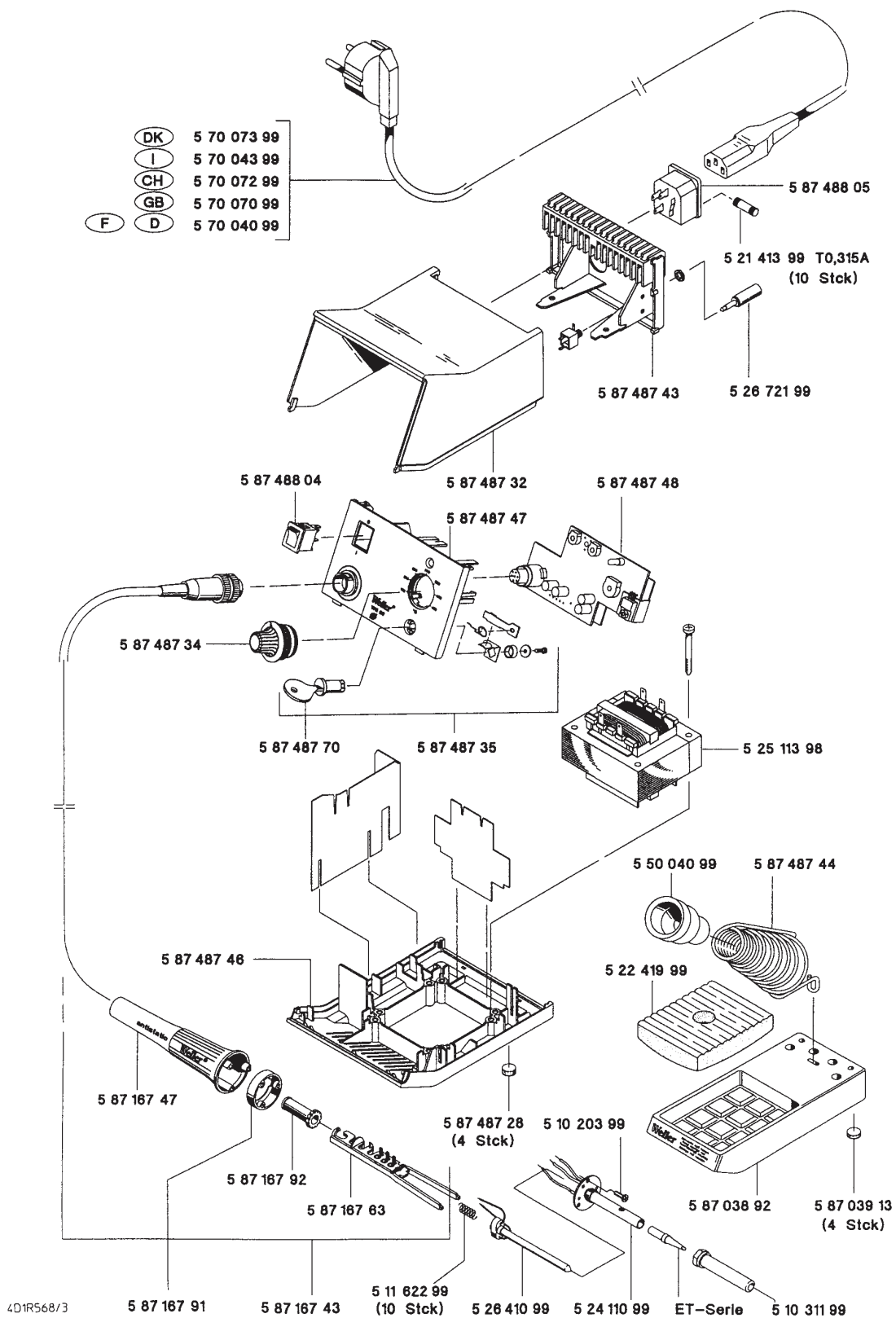

WSD 80

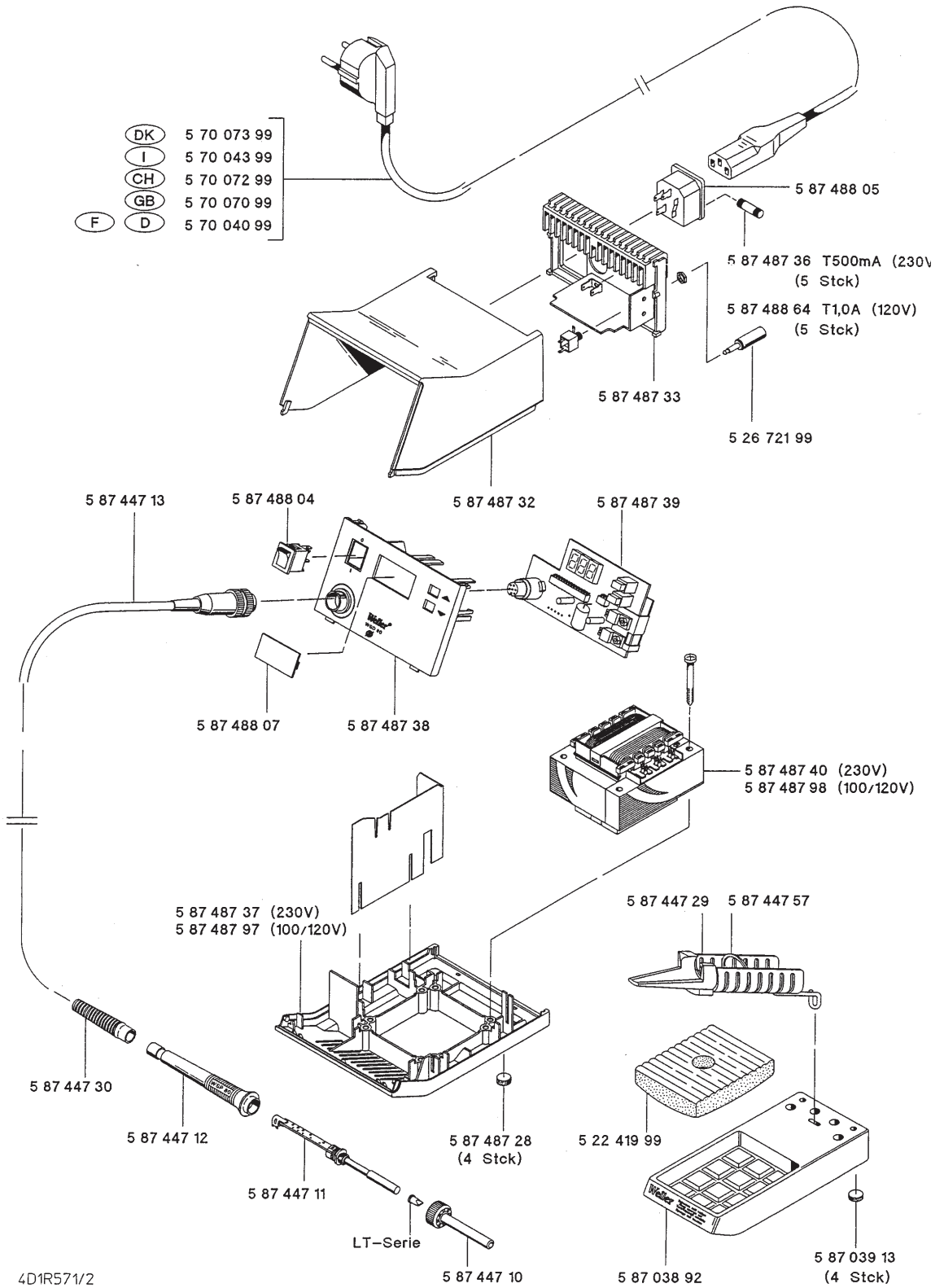

WSD 81



- (DK) 5 70 073 99
- (I) 5 70 043 99
- (CH) 5 70 072 99
- (GB) 5 70 070 99
- (F) (D) 5 70 040 99

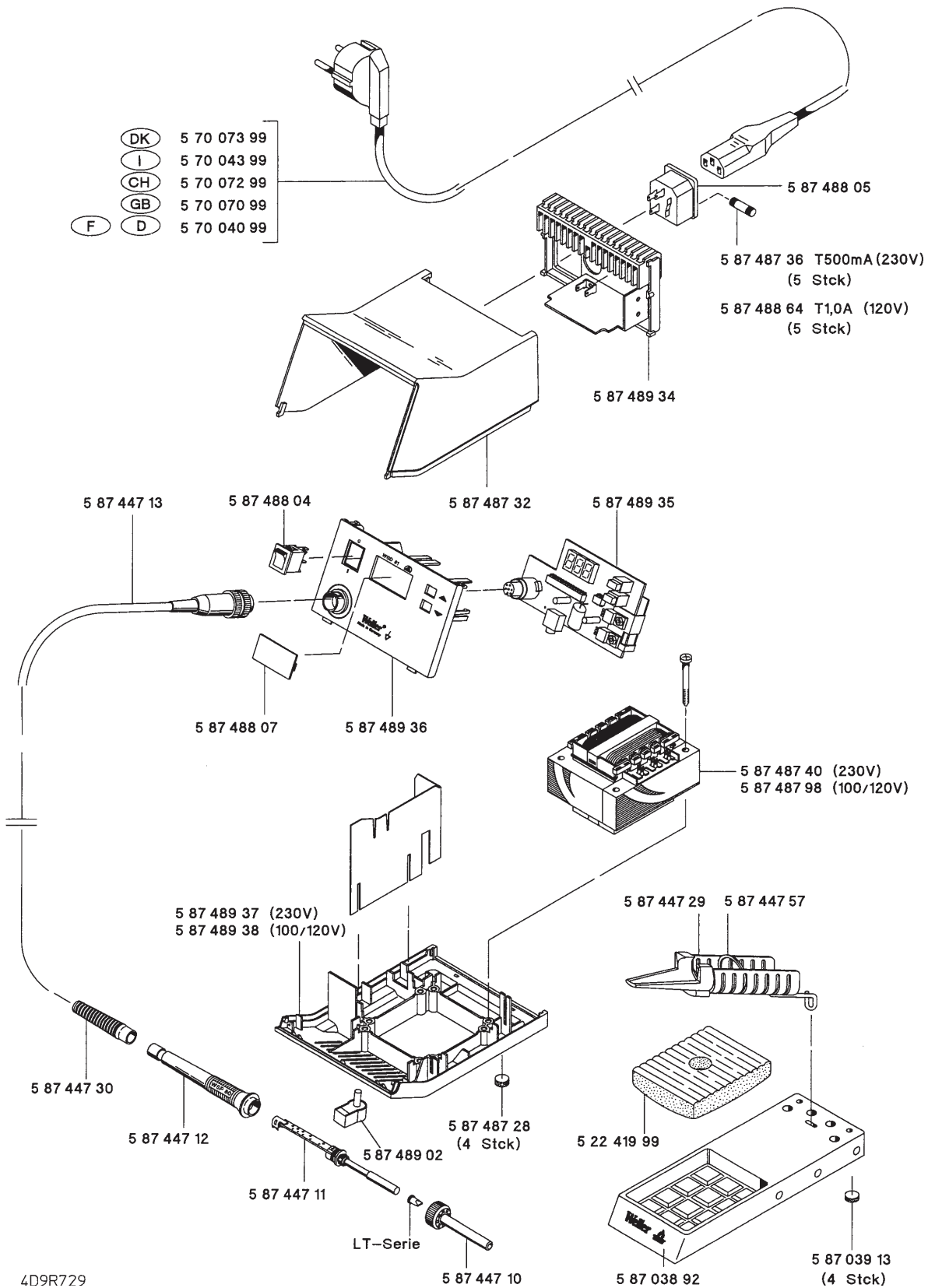

4D9R729

WSD 130

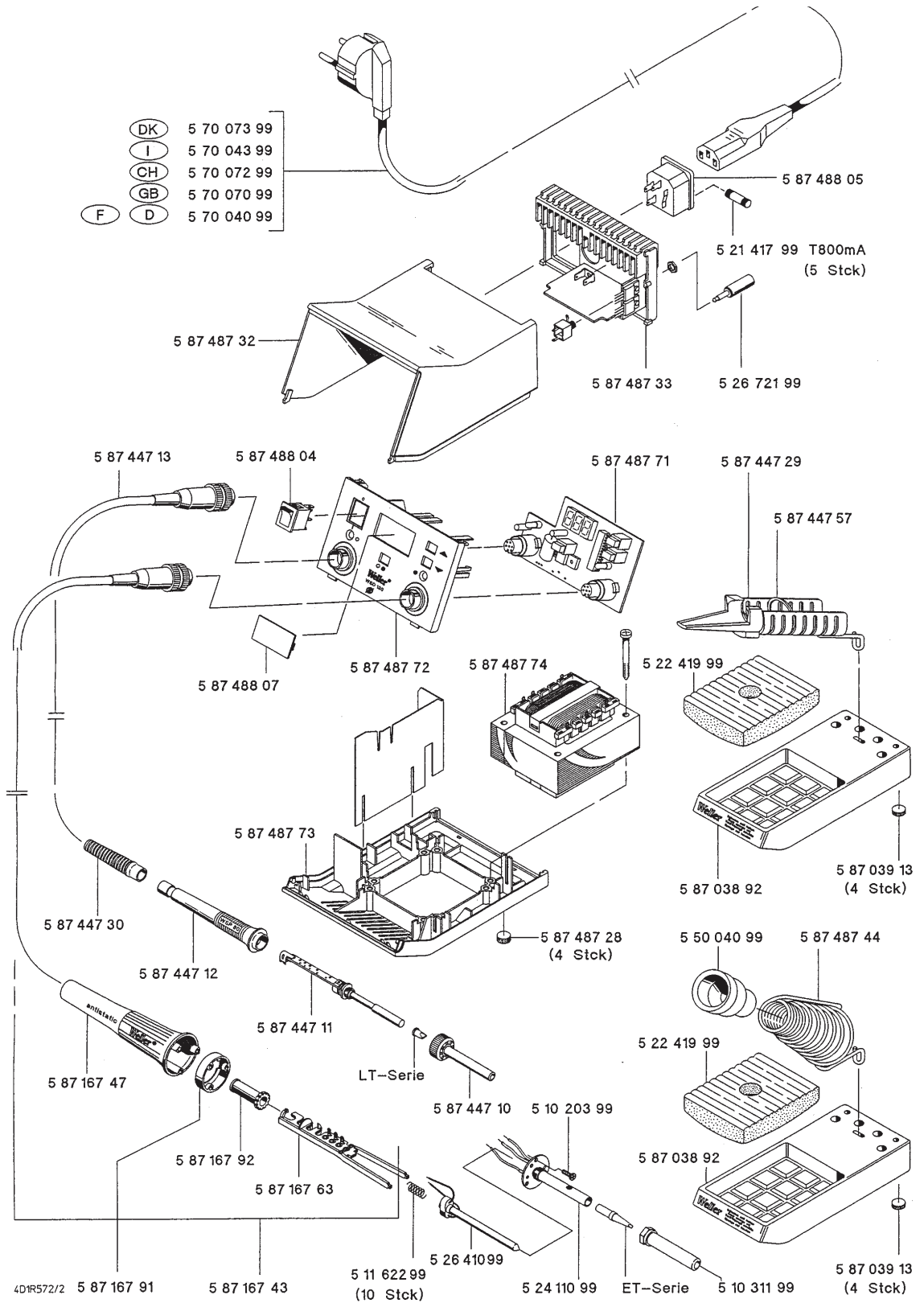

WSD 150



- DK 5 70 073 99
- I 5 70 043 99
- CH 5 70 072 99
- GB 5 70 070 99
- F 5 70 040 99
- D 5 70 040 99

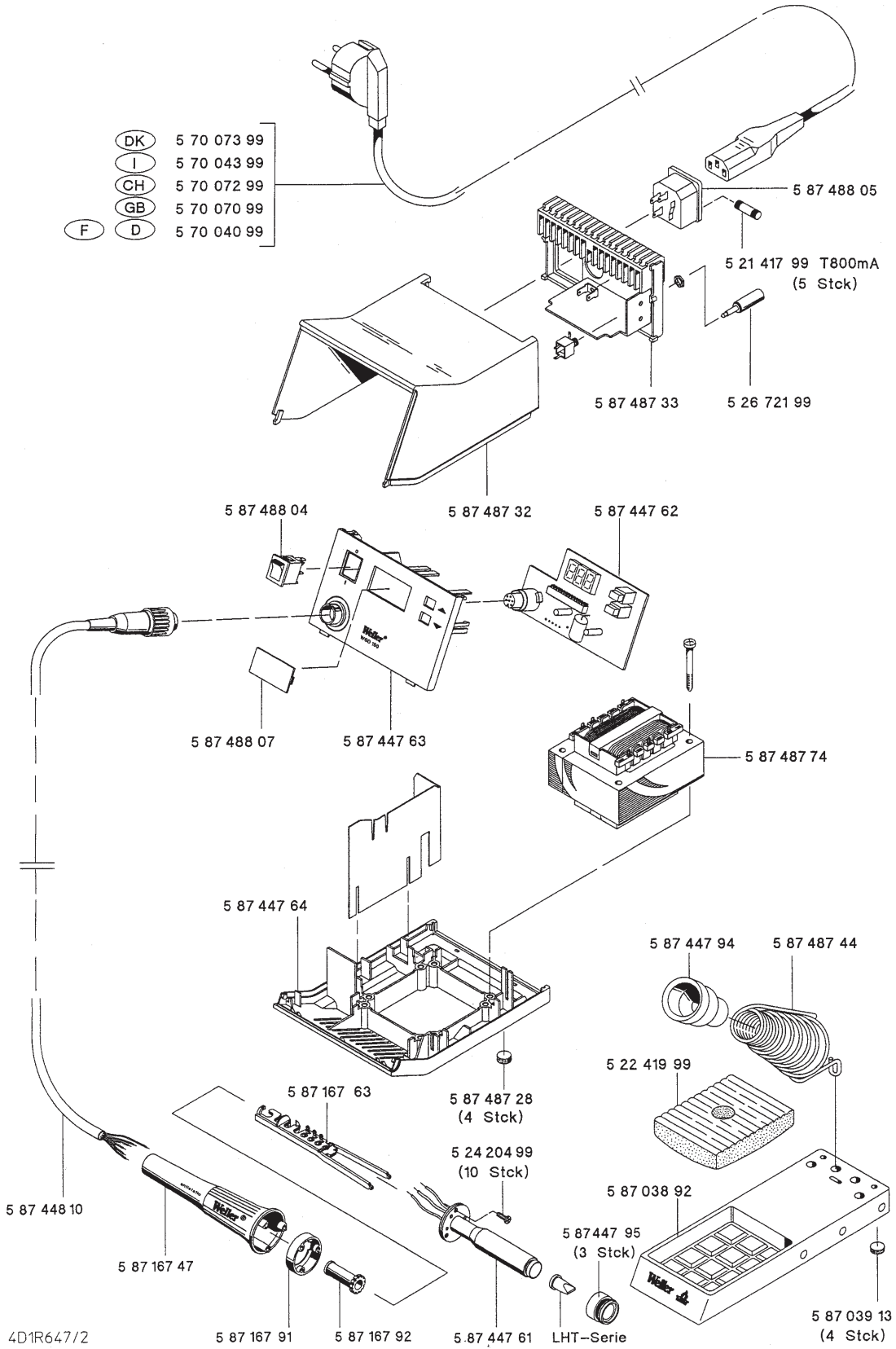

WSD 151

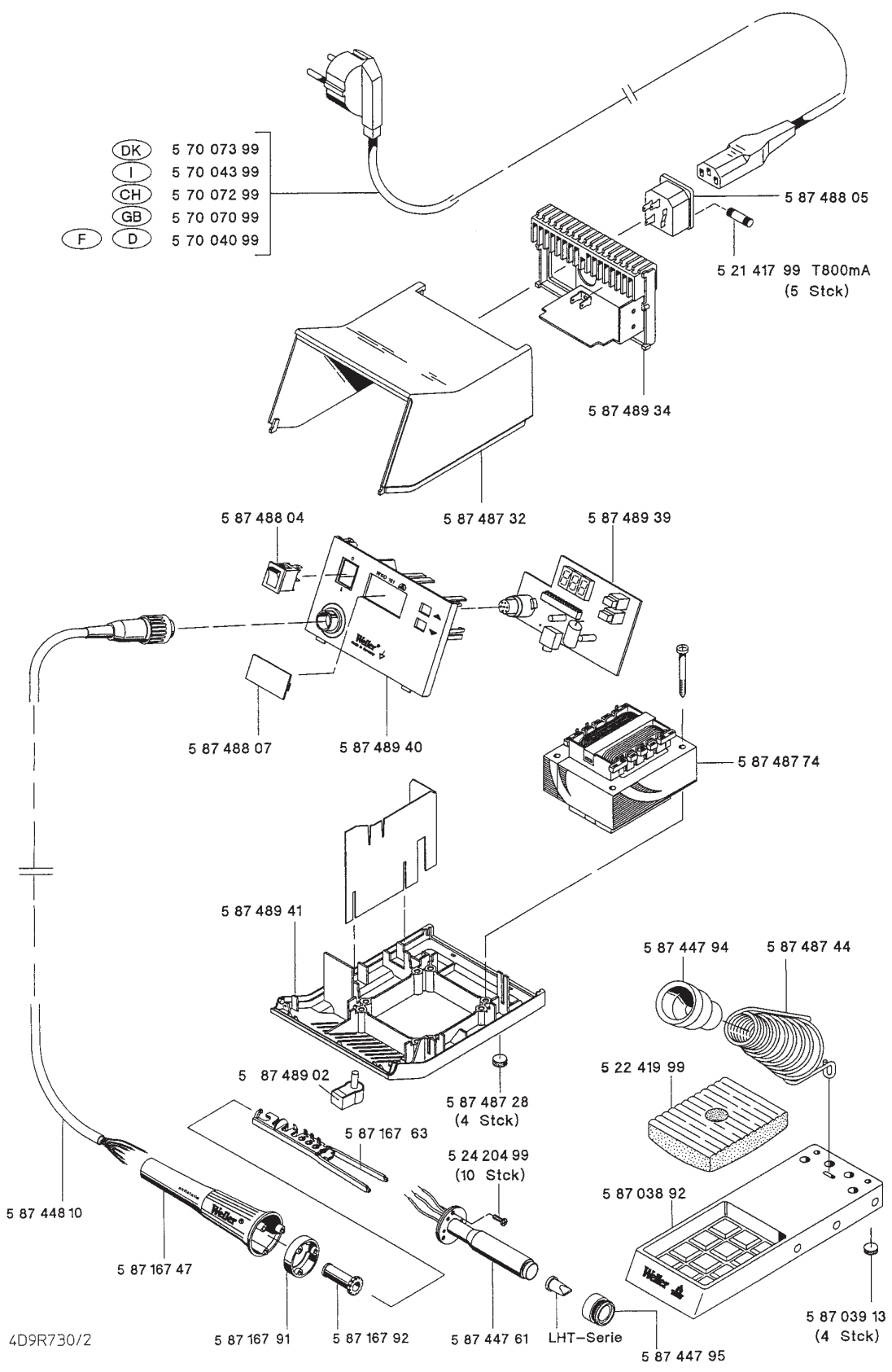

WSD 161

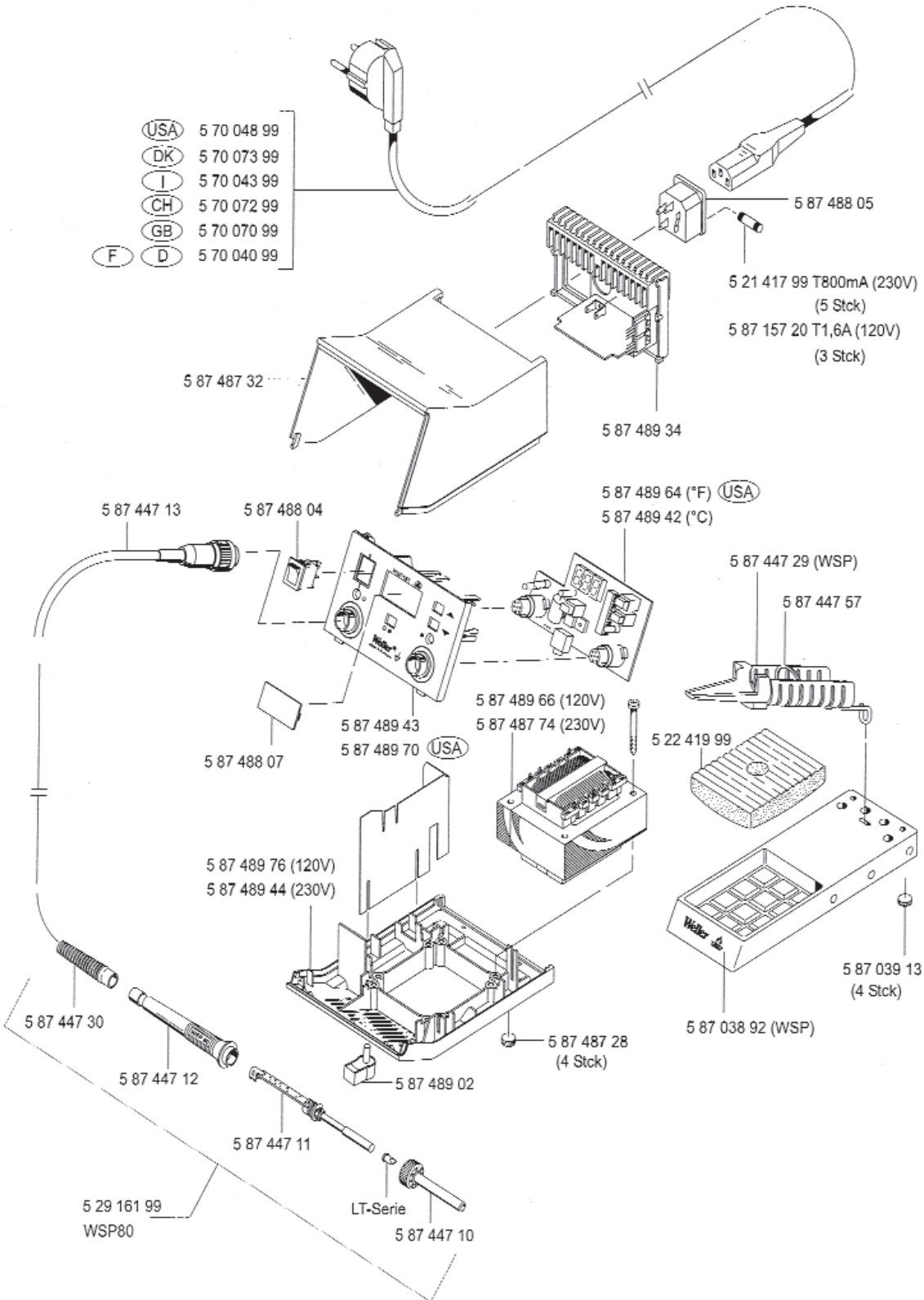

4D9R731/4
WSD 161

WSF 80D

Weller®

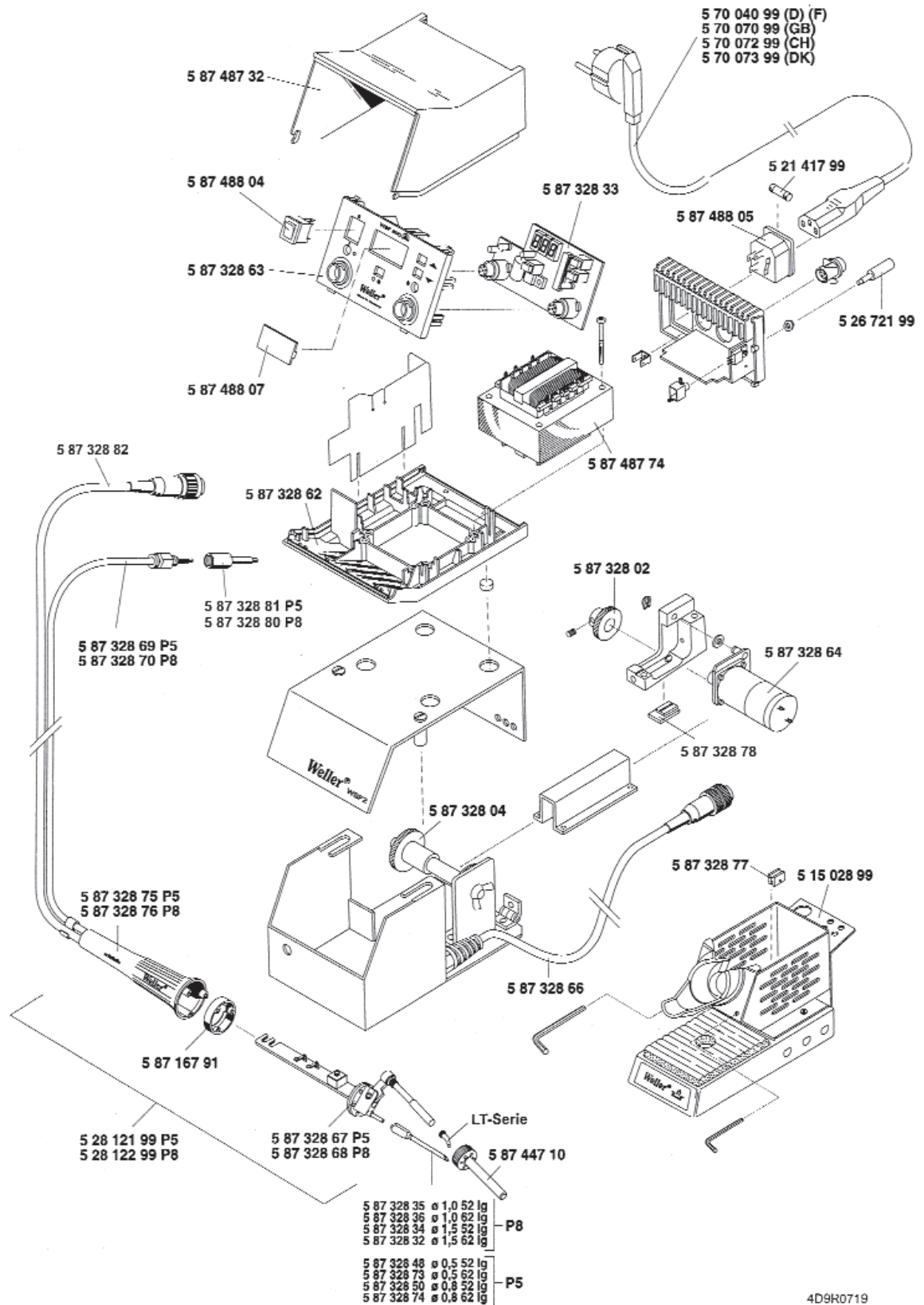

4D9R0719

WSF 81D

Weller®

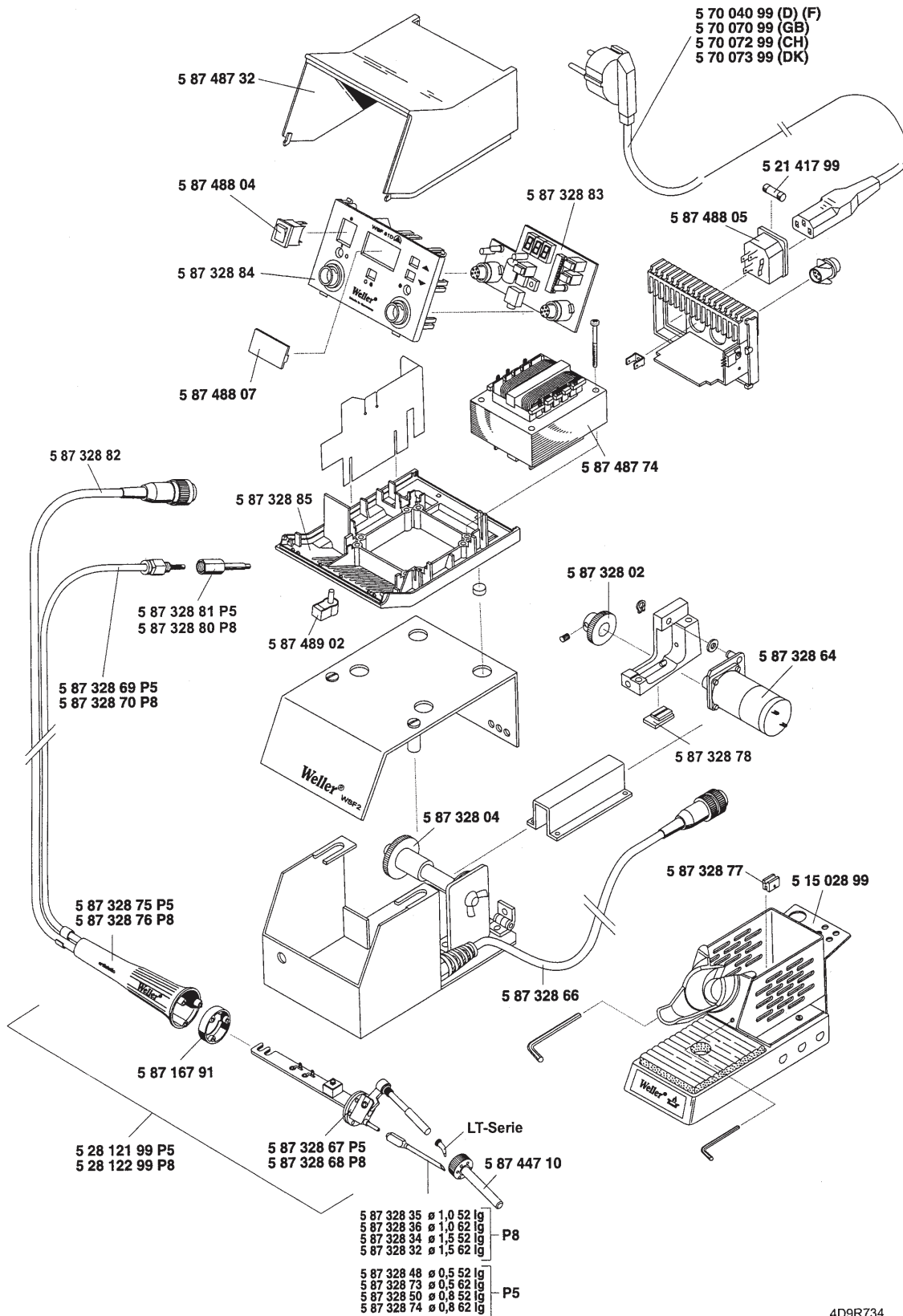

4D9R734

/3
irin

WT 50

Weller®

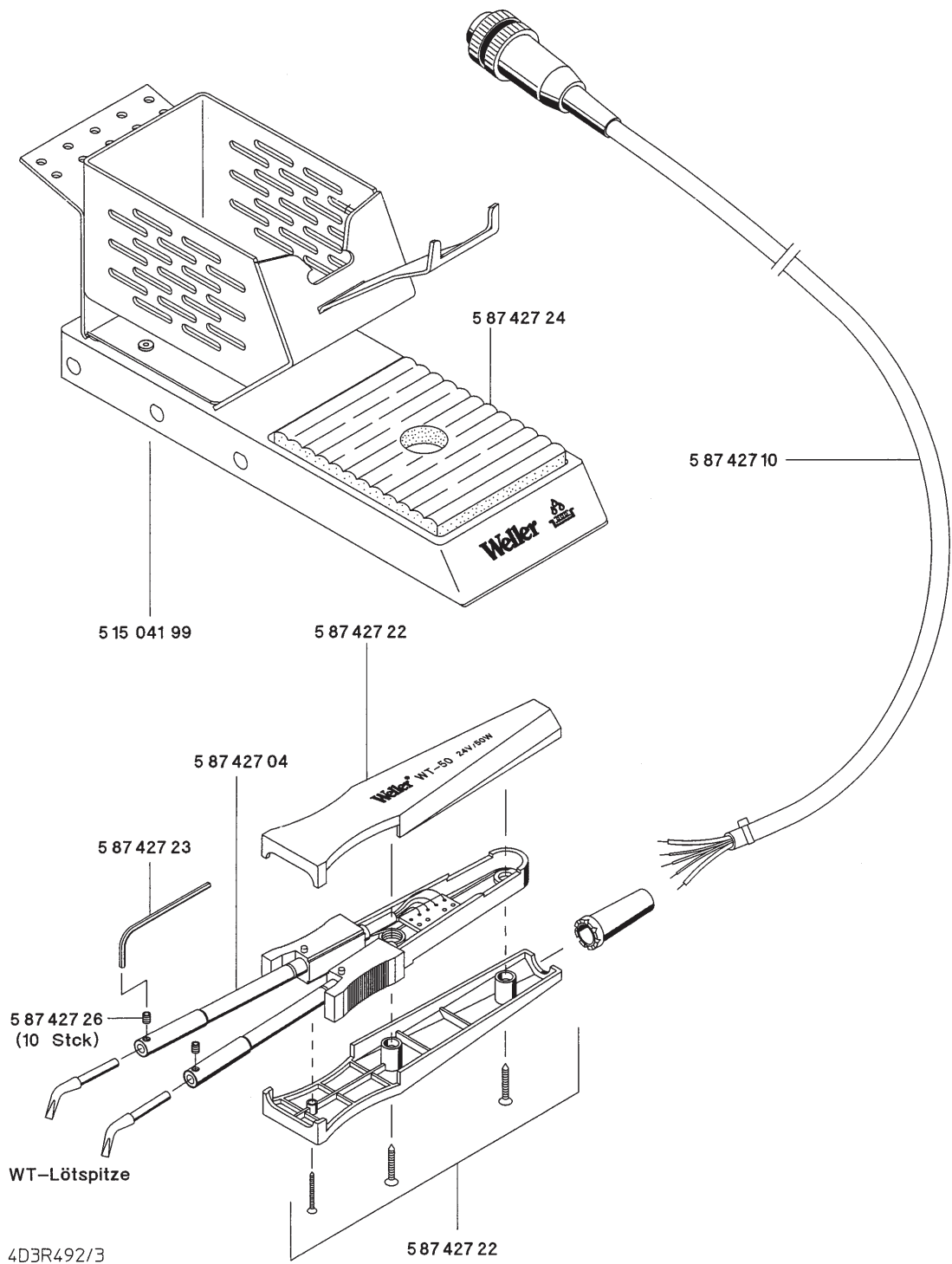

4D3R492/3
27.09.01 / Martin

WTCP 51

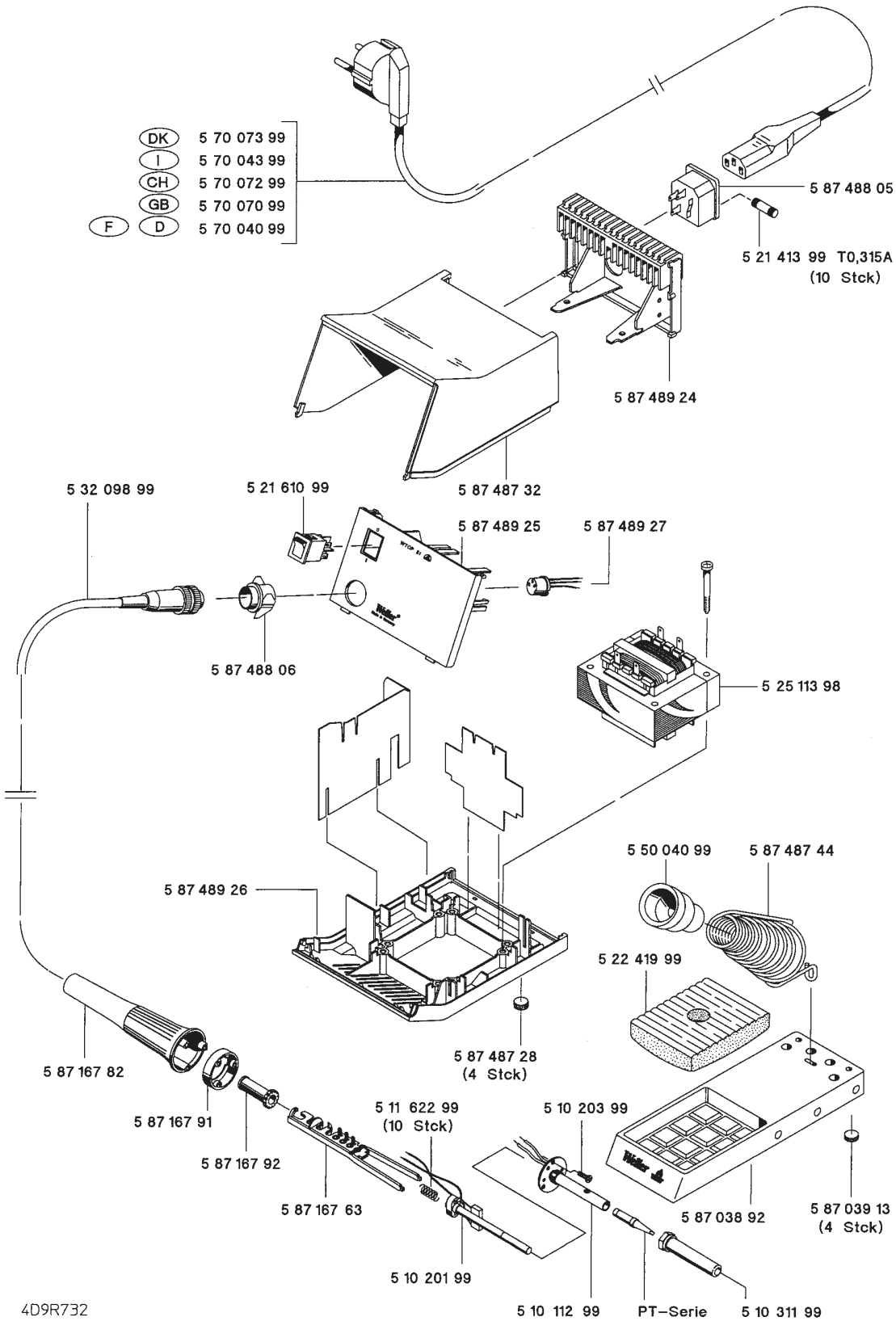

4D9R732

9/3
Marin

Компания «Life Electronics» занимается поставками электронных компонентов импортного и отечественного производства от производителей и со складов крупных дистрибьюторов Европы, Америки и Азии.

С конца 2013 года компания активно расширяет линейку поставок компонентов по направлению коаксиальный кабель, кварцевые генераторы и конденсаторы (керамические, пленочные, электролитические), за счёт заключения дистрибьюторских договоров

Мы предлагаем:

- Конкурентоспособные цены и скидки постоянным клиентам.
- Специальные условия для постоянных клиентов.
- Подбор аналогов.
- Поставку компонентов в любых объемах, удовлетворяющих вашим потребностям.
- Приемлемые сроки поставки, возможна ускоренная поставка.
- Доставку товара в любую точку России и стран СНГ.
- Комплексную поставку.
- Работу по проектам и поставку образцов.
- Формирование склада под заказчика.
- Сертификаты соответствия на поставляемую продукцию (по желанию клиента).
- Тестирование поставляемой продукции.
- Поставку компонентов, требующих военную и космическую приемку.
- Входной контроль качества.
- Наличие сертификата ISO.

В составе нашей компании организован Конструкторский отдел, призванный помогать разработчикам, и инженерам.

Конструкторский отдел помогает осуществить:

- Регистрацию проекта у производителя компонентов.
- Техническую поддержку проекта.
- Защиту от снятия компонента с производства.
- Оценку стоимости проекта по компонентам.
- Изготовление тестовой платы монтаж и пусконаладочные работы.



Тел: +7 (812) 336 43 04 (многоканальный)

Email: org@lifeelectronics.ru