

RO3144D

**916.5 MHz
SAW
Resonator**

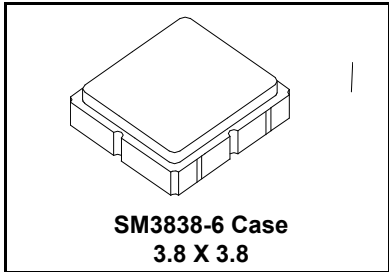

- Ideal for 916.5 MHz Remote Control and Data Telemetry Transmitters
- Very Low Series Resistance
- Quartz Stability
- Complies with Directive 2002/95/EC (RoHS)



The RO3144D is a true one-port, surface-acoustic-wave (SAW) resonator in a surface-mount ceramic case. It provides reliable, fundamental-mode stabilization of fixed-frequency transmitters operating at 916.5 MHz. This SAW resonator is designed specifically for use in remote control and data telemetry transmitters operating in the USA under FCC Part 15 regulations and in Canada under DoC RSS-210.

Absolute Maximum Ratings

Rating	Value	Units
Input Power Level	10	dBm
DC Voltage	12	VDC
Storage Temperature	-40 to +85	°C
Soldering Temperature (10 seconds / 5 cycles maximum)	260	°C

Electrical Characteristics

Characteristic		Sym	Notes	Minimum	Typical	Maximum	Units	
Frequency, +25 °C	RO3144D	f _C	2, 3, 4, 5	916.300		916.700	MHz	
	RO3144D-1			916.350		916.650		
	RO3144D-2			916.400		916.600		
Tolerance from 916.5 MHz	RO3144D	Δf _C				±200	kHz	
	RO3144D-1					±150		
	RO3144D-2					±100		
Insertion Loss		IL	2, 5, 6		1.20	2.5	dB	
Quality Factor	Unloaded Q	Q _U	5, 6, 7		6800			
	50Ω Loaded Q	Q _L			700			
Temperature Stability	Turnover Temperature	T _O	6, 7, 8	10	25	40	°C	
	Turnover Frequency	f _O			f _c			MHz
	Frequency Temperature Coefficient	FTC				0.032		ppm/°C ²
Frequency Aging	Absolute Value during the First Year	fA	1		10		ppm	
DC Insulation Resistance between Any Two Terminals			5	1.0			MΩ	
RF Equivalent RLC Model	Motional Resistance	R _M	5, 6, 7, 9		11.8		Ω	
	Motional Inductance	L _M			14		μH	
	Motional Capacitance	C _M			2.1		fF	
	Transducer Static Capacitance	C _O		5, 6, 9	2.1		pF	
Test Fixture Shunt Inductance		L _{TEST}	2, 7		14.3		nH	
Lid Symbolization	RO3144D 692, RO3144D-1 767, RO3144D-2 768 / YWWS							
Standard Reel Quantity	Reel Size 7 Inch		10	500 Pieces / Reel				
	Reel Size 13 Inch			3000 Pieces / Reel				

CAUTION: Electrostatic Sensitive Device. Observe precautions for handling.

- NOTES:**
1. Frequency aging is the change in f_C with time and is specified at +65 °C or less. Aging may exceed the specification for prolonged temperatures above +65 °C. Typically, aging is greatest the first year after manufacture, decreasing in subsequent years.
 2. The center frequency, f_C, is measured at the minimum insertion loss point, IL_{MIN}, with the resonator in the 50 Ω test system (VSWR ≤ 1.2:1). The shunt inductance, L_{TEST}, is tuned for parallel resonance with C_O at f_C. Typically, f_{OSCILLATOR} or f_{TRANSMITTER} is approximately equal to the resonator f_C.
 3. One or more of the following United States patents apply: 4,454,488 and 4,616,197.
 4. Typically, equipment utilizing this device requires emissions testing and government approval, which is the responsibility of the equipment manufacturer.
 5. Unless noted otherwise, case temperature T_C = +25 ± 2 °C.
 6. The design, manufacturing process, and specifications of this device are subject to change without notice.
 7. Derived mathematically from one or more of the following directly measured parameters: f_C, IL, 3 dB bandwidth, f_C versus T_C, and C_O.
 8. Turnover temperature, T_O, is the temperature of maximum (or turnover) frequency, f_O. The nominal frequency at any case temperature, T_C, may be calculated from: f = f_O [1 - FTC (T_O - T_C)²]. Typically oscillator T_O is approximately equal to the specified resonator T_O.
 9. This equivalent RLC model approximates resonator performance near the resonant frequency and is provided for reference only. The capacitance C_O is the static (nonmotional) capacitance between the two terminals measured at low frequency (10 MHz) with a capacitance meter. The measurement includes parasitic capacitance with "NC" pads unconnected. Case parasitic capacitance is approximately 0.05 pF. Transducer parallel capacitance can be calculated as: C_P ≈ C_O - 0.05 pF.
 10. Tape and Reel Standard Per ANSI/EIA 481.

Electrical Connections

The SAW resonator is bidirectional and may be installed with either orientation. The two terminals are interchangeable and unnumbered. The callout NC indicates no internal connection. The NC pads assist with mechanical positioning and stability. External grounding of the NC pads is recommended to help reduce parasitic capacitance in the circuit.

Pin	Connection
1	NC
2	Terminal
3	NC
4	NC
5	NC
6	Terminal
7	NC
8	NC

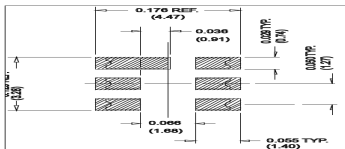
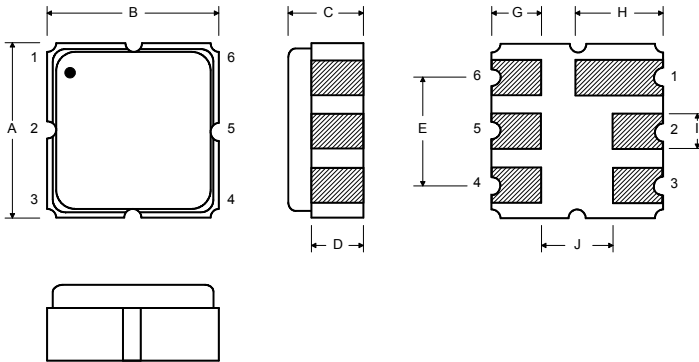

Case Dimensions

Dimension	mm			Inches		
	Min	Nom	Max	Min	Nom	Max
A	3.60	3.80	4.00	0.142	0.150	0.157
B	3.60	3.80	4.00	0.142	0.150	0.157
C	1.10	1.30	1.50	0.043	0.050	0.060
D	0.95	1.10	1.25	0.037	0.043	0.049
E	2.39	2.54	2.69	0.094	0.100	0.106
G	0.90	1.00	1.10	0.035	0.040	0.043
H	1.90	2.00	2.10	0.748	0.079	0.083
I	0.50	0.60	0.70	0.020	0.024	0.028
J	1.70	1.80	1.90	0.067	0.071	0.075

Equivalent RLC Model

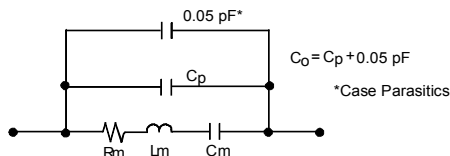

Parameter Test Circuit

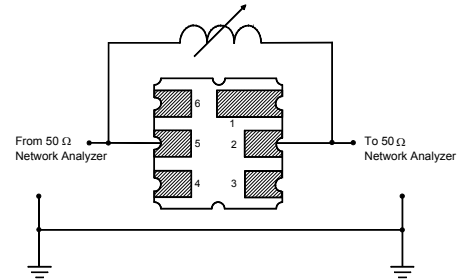

Power Test Circuit

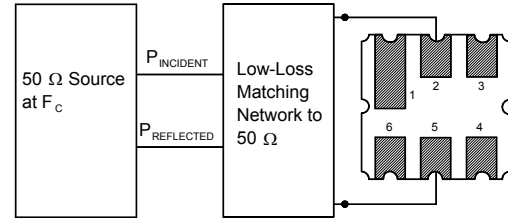

Example Application Circuits

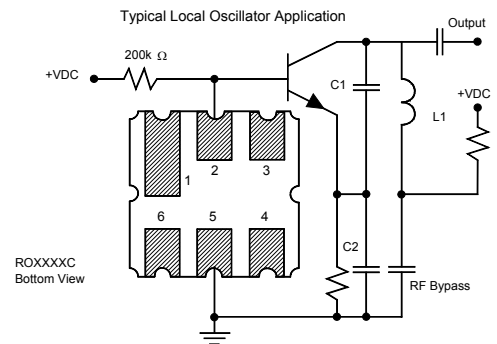
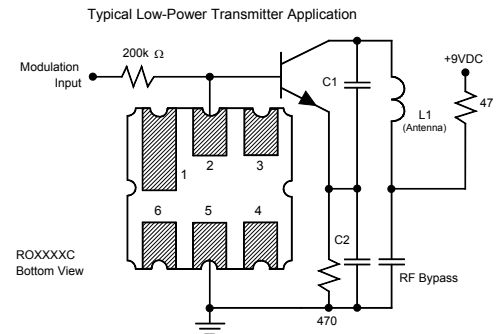

Temperature Characteristics

The curve shown on the right accounts for resonator contribution only and does not include LC component temperature contributions.

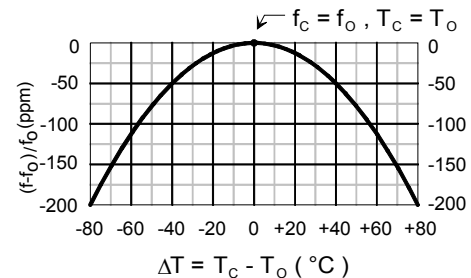

Компания «Life Electronics» занимается поставками электронных компонентов импортного и отечественного производства от производителей и со складов крупных дистрибьюторов Европы, Америки и Азии.

С конца 2013 года компания активно расширяет линейку поставок компонентов по направлению коаксиальный кабель, кварцевые генераторы и конденсаторы (керамические, пленочные, электролитические), за счёт заключения дистрибьюторских договоров

Мы предлагаем:

- Конкурентоспособные цены и скидки постоянным клиентам.
- Специальные условия для постоянных клиентов.
- Подбор аналогов.
- Поставку компонентов в любых объемах, удовлетворяющих вашим потребностям.
- Приемлемые сроки поставки, возможна ускоренная поставка.
- Доставку товара в любую точку России и стран СНГ.
- Комплексную поставку.
- Работу по проектам и поставку образцов.
- Формирование склада под заказчика.
- Сертификаты соответствия на поставляемую продукцию (по желанию клиента).
- Тестирование поставляемой продукции.
- Поставку компонентов, требующих военную и космическую приемку.
- Входной контроль качества.
- Наличие сертификата ISO.

В составе нашей компании организован Конструкторский отдел, призванный помогать разработчикам, и инженерам.

Конструкторский отдел помогает осуществить:

- Регистрацию проекта у производителя компонентов.
- Техническую поддержку проекта.
- Защиту от снятия компонента с производства.
- Оценку стоимости проекта по компонентам.
- Изготовление тестовой платы монтаж и пусконаладочные работы.



Тел: +7 (812) 336 43 04 (многоканальный)

Email: org@lifeelectronics.ru