



DC651A DEMO BOARD QUICK START GUIDE

Description:

The DC651A demo circuit board is intended to demonstrate the capabilities of the LT[®]5522 high-signal-level downconverting mixer IC for cable and CATV infrastructure applications.

The LT[®]5522 (Figure 1) is a broadband high signal level active mixer optimized for high linearity downconverter applications including cable (CATV) and wireless infrastructure. The IC includes a high-speed differential LO buffer amplifier driving a double-balanced mixer. The LO buffer is internally 50ohm-matched for wideband, single-ended operation with no external components.

The LT5522 IC's RF input port incorporates an integrated transformer and is internally matched to 50ohms over the 1.2GHz to 2.3GHz frequency range. The RF input match can be shifted down to 600MHz, or up to 2.7GHz, with a single shunt capacitor or inductor, respectively. The high level of integration minimizes the total solution cost, board space and system-level variation.

The LT5522 delivers high performance and small size without excessive power consumption.

The DC651A demo board allows evaluation of the LT5522 downconverting mixer IC for cable infrastructure applications. Its RF input is optimized for 1150MHz. The IF output frequency range spans 50MHz to 1050MHz. The corresponding range of LO frequencies is 1200MHz to 2200MHz.

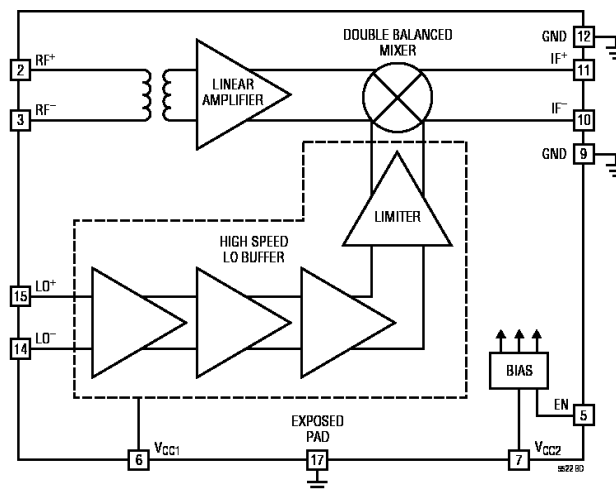

Figure 1. LT5522 IC Block Diagram

LT5522 Downconverting Mixer Single-Tone Measurements for CATV Band.

1. Connect all test equipment as shown in Figure 2.
2. Set the Power Supply voltage to 5V, and set the current limit to 100mA.
3. Connect TP1 (EN) to the 5V power supply; the mixer is enabled (on).
4. Set the Signal Generator #1 to provide a -5dBm CW signal, at the desired LO frequency between 1200MHz and 2200MHz (e.g., 1650MHz), to the demo board LOin port.
5. Set the Signal Generator #2 to provide a 1150MHz, -12 dBm CW signal to the demo board RFin port.
6. Set the Spectrum Analyzer center frequency to the IF output frequency at $f_{LO}-f_{RF}$ (e.g., 500MHz). Perform mixer conversion gain, and 1dB compression measurements.
7. Set the Spectrum Analyzer center frequency to the LO frequency (e.g., 1650MHz). Perform mixer LO to IF leakage measurement.

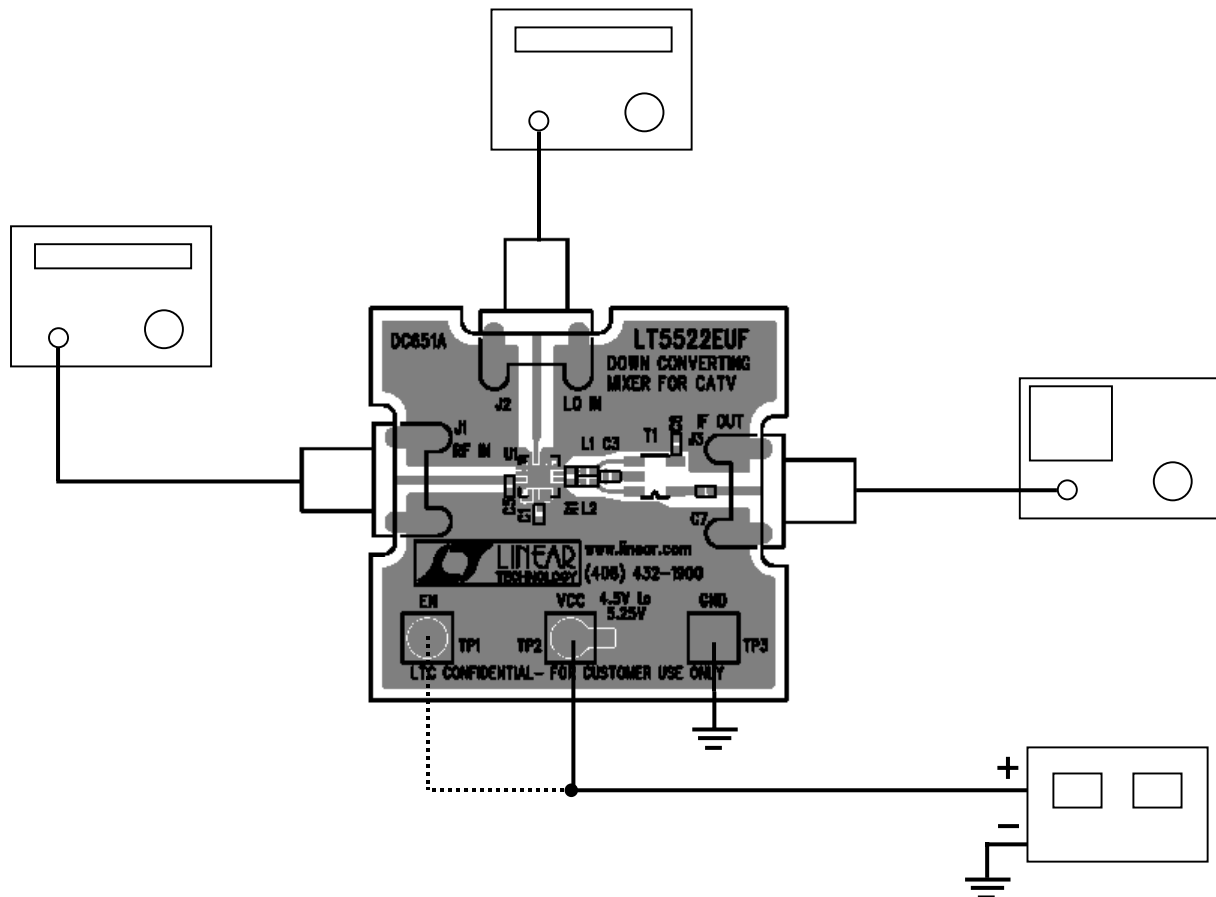

Figure 2. Test Set-Up for Mixer Single-Tone Measurements.

LT5522 Downconverting Mixer Two-Tone Measurements for CATV Band.

1. Connect all test equipment as shown in Figure 3.
 - 1). Use high quality signal generators with low harmonic output for this measurement. Otherwise, low-pass filters should be used to suppress harmonics.
 - 2). A high quality combiner that provides 50ohm termination on all ports and has good port-to-port isolation should be used.
 - 3). The two 3dB attenuators on the inputs of the combiner are used to further improve source isolation.
2. Set the Power Supply voltage to 5V, and set the current limit to 100mA.
3. Connect TP1 (EN) to the 5V power supply. Mixer is enabled (on).
4. Set the Signal Generator #1 to provide a -5dBm CW signal, at the desired LO frequency between 1200MHz and 2200MHz (e.g. 1650MHz), to the demo board LOin port.
5. Set the Signal Generator #2 and #3 to provide two -12dBm CW signals to the demo board RFin port—one at 1150MHz, and the other at 1151MHz.
6. Set the Spectrum Analyzer center frequency to the IF output frequency at $f_{LO}-f_{RF}$. Perform input 3rd order distortion measurement (i.e. $IIP3 = P_1 + (P_1 - P_3) / 2 - G_c$, where P_1 is the lowest power level of the two desired output tones at either 499MHz or 500MHz, P_3 is the largest 3rd order product at either 498MHz or 501MHz, and G_c is conversion gain. P_1 and P_3 are in units of dBm, and G_c is in dB).

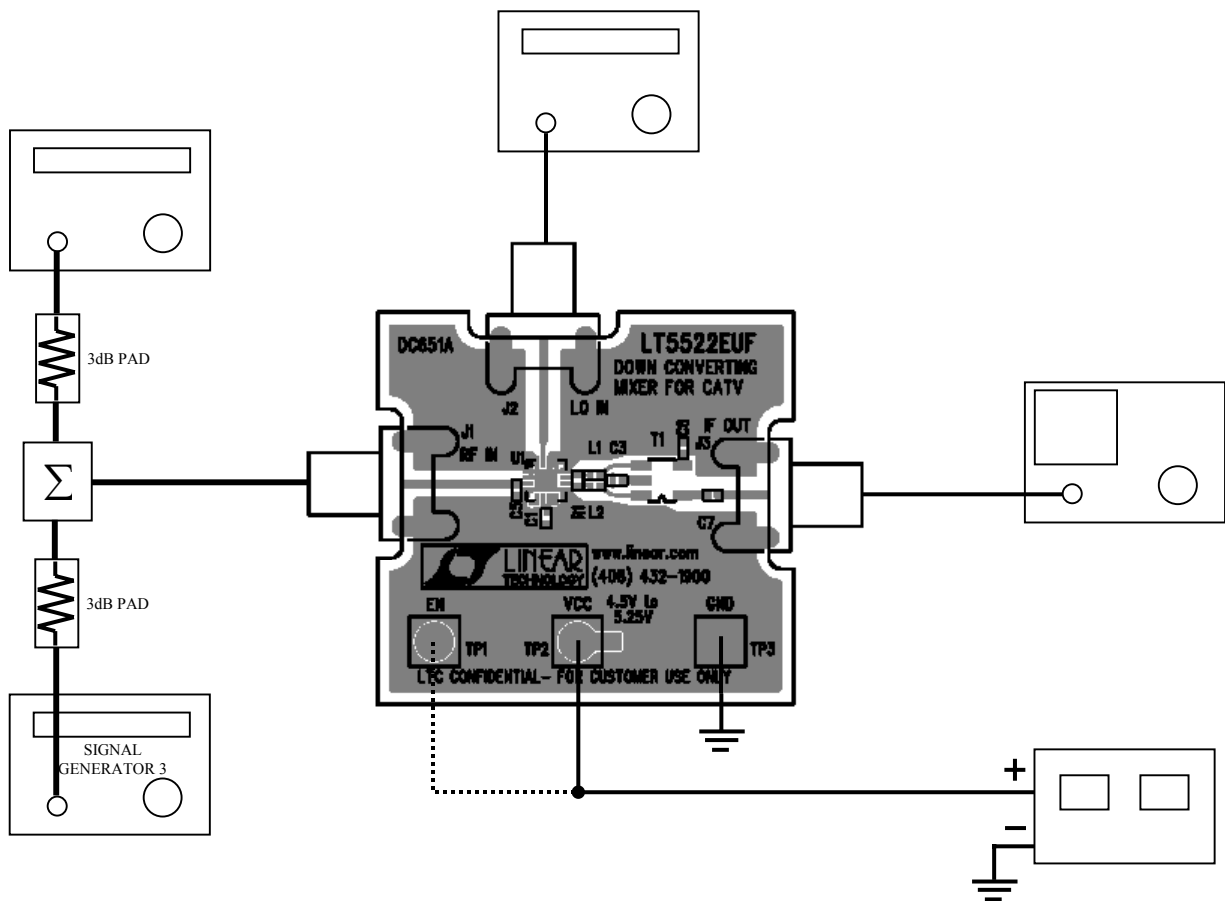
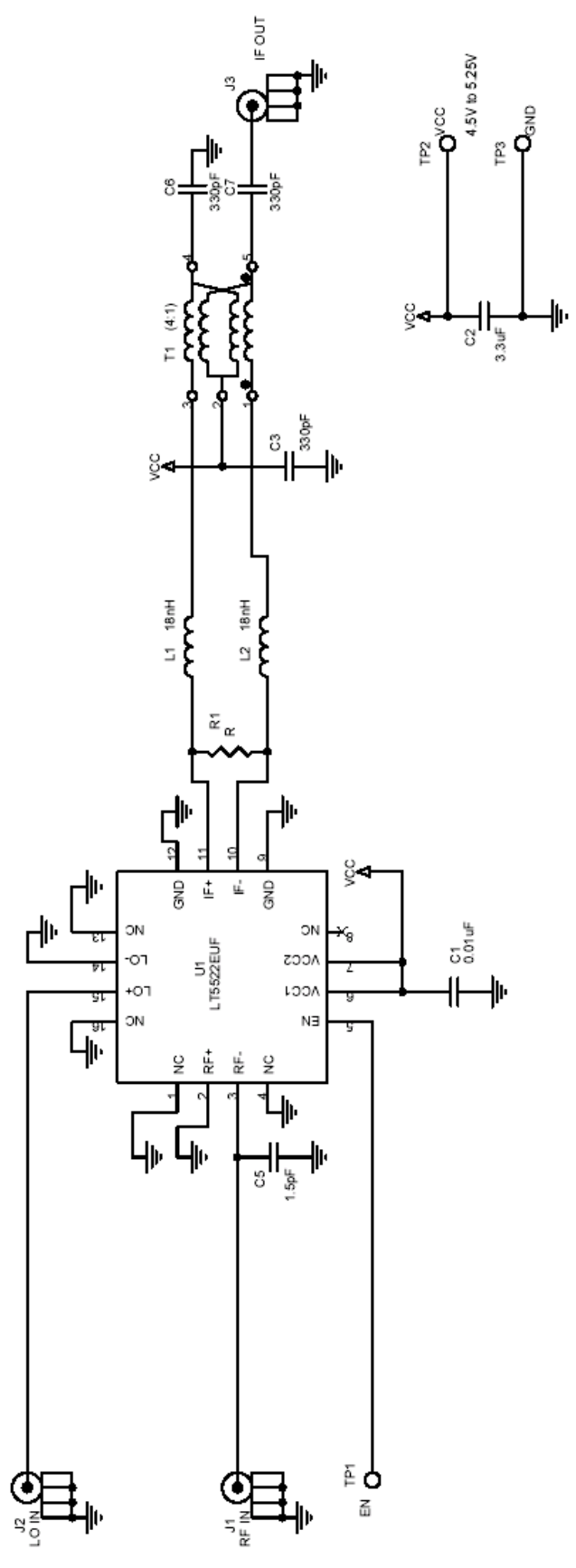

Figure 3. Test Set-Up for Mixer Two-Tone Measurements.

This circuit is proprietary to Linear Technology and supplied for use with Linear Technology parts.
Customer Notice Linear Technology has made a best effort to design a circuit that meets customer-supplied specifications; however, it remains the customer's responsibility to verify proper and reliable operation in the actual application. Component substitution and printed circuit board layout may significantly affect circuit performance or reliability. Contact Linear Applications Engineering for assistance.



REVISION HISTORY				
ECO	REV	DESCRIPTION	DATE	APPROVED
	2	PROTO	04/30/03	

		1630 McCarthy Blvd. Milpitas, CA 95035 Phone: (408)432-1900 Fax: (408)434-0507	
TITLE SCH, LT5522EUF DOWN CONVERTING MIXER FOR CATV			
SIZE	CAGE CODE	DWG NO	REV
A		DC651A	2
SCALE	NONONE	FILENAME	S51A-2.DSN
SHEET	1	OF	1

UNLESS OTHERWISE SPECIFIED DIMENSIONS ARE IN INCHES TOLERANCE ON ANGLE 2 PLACES .3 PLACES INTERPRET DIM AND TOL PER ASME Y14.5M-1994 THIRD ANGLE PROJECTION		
CONTRACT NO. APPROVALS DRAWN MEI CHECKED APPROVED ENGINEER DESIGNER		DATE 04/30/03
DO NOT SCALE DRAWING		Wednesday, October 29, 2003

Компания «Life Electronics» занимается поставками электронных компонентов импортного и отечественного производства от производителей и со складов крупных дистрибьюторов Европы, Америки и Азии.

С конца 2013 года компания активно расширяет линейку поставок компонентов по направлению коаксиальный кабель, кварцевые генераторы и конденсаторы (керамические, пленочные, электролитические), за счёт заключения дистрибьюторских договоров

Мы предлагаем:

- Конкурентоспособные цены и скидки постоянным клиентам.
- Специальные условия для постоянных клиентов.
- Подбор аналогов.
- Поставку компонентов в любых объемах, удовлетворяющих вашим потребностям.
- Приемлемые сроки поставки, возможна ускоренная поставка.
- Доставку товара в любую точку России и стран СНГ.
- Комплексную поставку.
- Работу по проектам и поставку образцов.
- Формирование склада под заказчика.
- Сертификаты соответствия на поставляемую продукцию (по желанию клиента).
- Тестирование поставляемой продукции.
- Поставку компонентов, требующих военную и космическую приемку.
- Входной контроль качества.
- Наличие сертификата ISO.

В составе нашей компании организован Конструкторский отдел, призванный помогать разработчикам, и инженерам.

Конструкторский отдел помогает осуществить:

- Регистрацию проекта у производителя компонентов.
- Техническую поддержку проекта.
- Защиту от снятия компонента с производства.
- Оценку стоимости проекта по компонентам.
- Изготовление тестовой платы монтаж и пусконаладочные работы.



Тел: +7 (812) 336 43 04 (многоканальный)

Email: org@lifeelectronics.ru