

Specifications

Drawing No.	USY1N-H1-18402-00	1 / 7
Issued Date.	Jun,3,2018	

Messrs: Mouser

Note: Part Number will be revised in case of specification change.

Product Type	Tuning Fork Crystal	
Series	ST3215SB	
Frequency	32.768 kHz	
Customer Part Number	-	
Customer Specification Number	-	
KYOCERA Part Number	ST3215SB32768H5MRXA1	
Remarks	Pb-Free, RoHS Compliant, MSL 1 AEC Q200 conformity.	

Customer Approval

Approval Signature	Approved Date	
	Department	
	Person in charge	

Seller

KYOCERA Corporation

Corporate Electronic Components Group
Electronic Components Sales Division
6 Takeda Tobadono-cho, Fushimi-ku, Kyoto
612-8501 Japan
TEL: 075-604-3500 FAX: 075-604-3501

Manufacturer

Corporate Electronic Components Group
Crystal Components Division
Shiga Yohkaichi Plant
1166-6 Hebimizo-cho, Higashiomi, Shiga
527-8555 Japan
TEL: 0748-22-1550 FAX: 0748-22-1590

Design Department	Quality Assurance	Approved by	Checked by	Issued by
KYOCERA Corporation Crystal Units Design Engineering Section Crystal Product Division	S.Honma	T.Soda	A.Muraoka	R.Yoshida Y.Nozaki

Revision History

Rev.No.	Description of revision	Date	Approved by	Checked by	Issued by
0	First Edition	Jun,3,2018	T.Soda	A.Muraoka	R.Yoshida Y.Nozaki

1. APPLICATION

This specification sheet is applied to tuning fork crystal "ST3215SB"
for Automotive(Non-Safety Application).

2. PART NUMBER

ST3215SB32768H5MRXA1

3. RATINGS

Items	SYMB.	Rating	Unit
Operating Temperature range	Topr	-40~+105	deg. C
Storage Temperature range	Tstg	-55~+125	deg. C

4. CHARACTERISTICS

4-1 ELECTRICAL CHARACTERISTICS

Item	Symbol	Electrical Specification				
		Condition	Min	Typ.	Max	Unit
Nominal Frequency	fo	Ta = 25 deg. C		32.768		kHz
Frequency Tolerance	df/fo	Ta = 25 deg.C	-40		40	ppm
Frequency Temperature Characteristics	dFT	At Operating Temperature	-300		300	ppm
Load Capacitance	CL			12.5		pF
Equivalent series resistance	R1				70	kΩ
Q-Value	Q		13000			
Motional capacitance	C1		3.0		4.4	fF
Shunt capacitance	Co		0.6		1.2	pF
Tuning point	Tp		20		30	deg. C
Secondary temperature Coefficient	K		-4.0			10 ⁻⁸ /degC ²
Aging	df/F	Ta = 25 deg. C	-3		3	ppm/year
Drive level	DL			0.1	0.5	μW
Insulation resistance (between electrodes)	IR		500			MΩ

4-2 MOISTURE SENSITIVITY LEVEL

Level 1

5. APPEARANCES, DIMENSIONS
OUTLINE DIMENSIONS (not to scale)
(TOP VIEW)

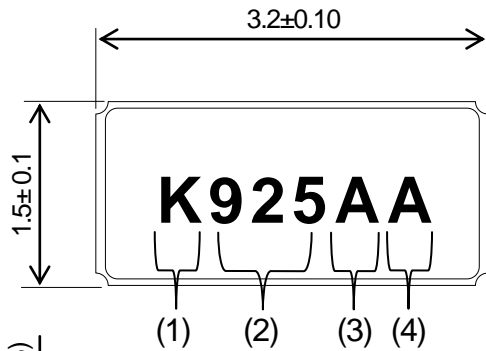

CONNECTION (TOP VIEW)

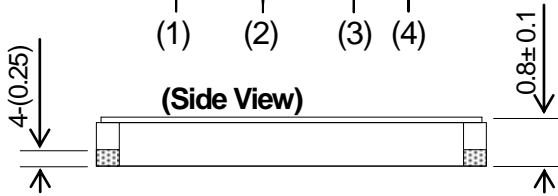
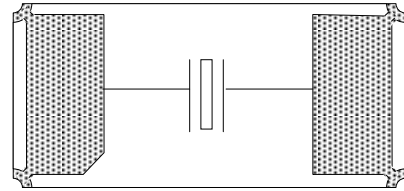

(Bottom View)

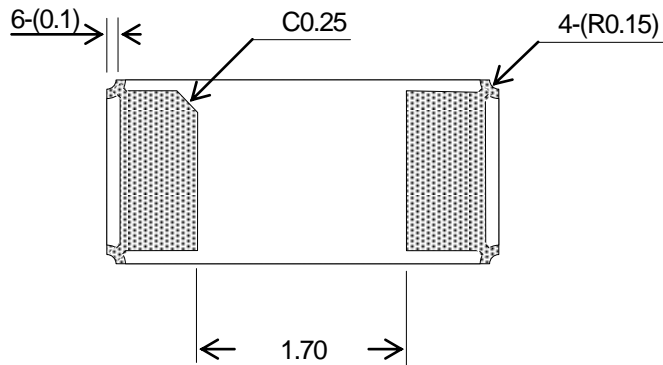

UNIT : mm

MARKING

- (1) Identification K
- (2) Date Code(3 Digits) Last 1 digit of year and week Code.
- (3) Load Capacitance (Example) 12.5pF → A
- (4) Management number Alphabet or Number 1digit.

*The font of marking above is for reference purpose.

6. RECOMMENDED LAND PATTERN

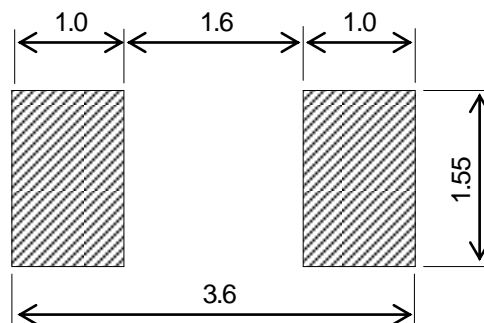

UNIT : mm

7. RELIABILITY

(Reference: AEC-Q200 Rev. D. The solder used by examination is hereafter set to Sn-3Ag-0.5Cu.)

Frequency Stability and ESR Stability After stressing.

No	Stress	Reference	Additional Requirements
7.1	High Temperature Exposure (Storage)	MIL-STD-202 Method 108	1000 hrs. at rated operating temperature (e.g. 85°C part can be stored for 1000 hrs at 85°C. Same applies for 125°C). Unpowered. Measurement at 24±4 hours after test conclusion.
7.2	Temperature Cycling	JESD22 Method JA-104	1000 cycles (-55°C to 125°C) Note: If -40°C , 85°C part the 1000 cycles will be at that temperature rating. Measurement at 24±4 hours after test conclusion. 30min maximum dwell time at each temperature extreme. 1 min. maximum transition time.
7.3	Biased Humidity	MIL-STD- 202 Method 103	1000 hours 85°C/85%RH. Rated VDD applied with 1 MW and inverter in parallel, 2X crystal CL capacitors between each crystal leg and GND. Measurement at 24±4 hours after test conclusion.
7.4	Operational Life	MIL-STD- 202 Method 108	Note: 1000 hrs @ 125°C. If 85°C part will be tested at that temperature. Rated VDD applied with 1 MW and inverter in parallel, 2X crystal CL capacitors between each crystal leg and GND. Measurement at 24±4 hours after test conclusion.
7.5	Terminal Strength (Leaded)	MIL-STD- 202 Method 211	Test leaded device lead integrity only. Conditions: A (227 g), C (227 g).
7.6	Resistance to Solvents	MIL-STD- 202 Method 215	Note: Also aqueous wash chemical - OKEM clean or equivalent. Do not use banned solvents.
7.7	Mechanical Shock	MIL-STD-202 Method 213	Figure 1 of Method 213. Condition C
7.8	Vibration	MIL-STD-202 Method 204	5g's for 20 minutes 12 cycles each of 3 orientations. Note: Use 8"X5" PCB .031" thick with 7 secure points on one 8" side and 2 secure points on corners of opposite sides. Parts mounted within 2" from any secure point. Test from 10-2000 Hz.
7.9	Resistance to Soldering Heat	MIL-STD-202 Method 210	Condition B No pre-heat of samples. Note: Single Wave solder - Procedure 1 with solder within 1.5 mm of device body for Leaded. Procedure 1 except 230°C and immerse only to level to cover terminals for SMD.
7.10	Solderability	J-STD-002	For both Leaded & SMD. Electrical Test not required. Magnification 50 X. Conditions: Leaded: Method A @ 235°C, category 3. SMD: a) Method B, 4 hrs @ 155°C dry heat @ 235°C b) Method B @ 215°C category 3. c) Method D category 3 @ 260°C.
7.11	Flammability	UL-94	V-0 or V-1 Acceptable
7.12	Board Flex	AEC Q200-005	60 sec minimum holding time.
7.13	Terminal Strength(SMD)	AEC Q200-006	The static load of 1.8Kg is added in the direction of the arrow and it maintains it in the prime fields of parts for 60 sec with a scratch treatment device of R0.5.

8. REFLOW PROFILE

Pb-free reflow requirements for soldering heat resistance

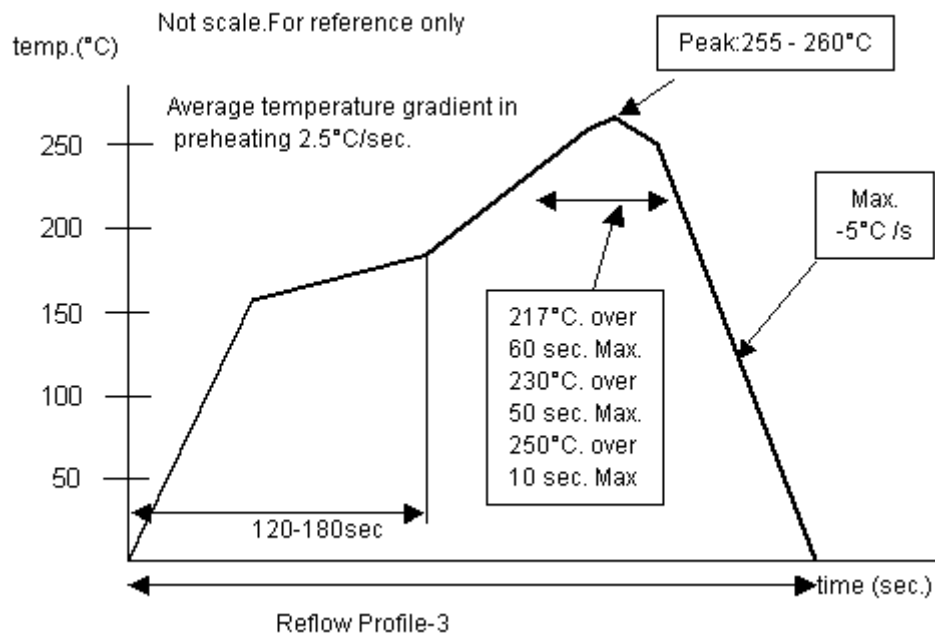

9. Cautions for use

(1) Soldering upon mounting

Characteristics may be affected when Solder paste or conductive glue comes in contact with product lid or surface.

(2) When using mounting machine

Please minimize the shock when using mounting machine to avoid any excess stress to the product.

(3) Conformity of a circuit

We strongly recommend to make sure that Negative resistance (Gain) of IC is designed to be 3 times the ESR (Equivalent Series Resistance) of Crystal unit.

10. Storage conditions

Please store product in below conditions, and use within 6 months.

Temperature +18 to +30°C, and Humidity of 20 to 70 % in the packaging condition.

11. Manufacturing location

Kyocera Crystal Device Corporation Shiga Yohkaichi Plant

12. Quality Assurance

To be guaranteed by Kyocera Crystal Device Quality Assurance Division

13. Quality guarantee

When Kyocera Crystal Device Corporation rooted failure occurs within 1 year after its delivery, substitute product will be arranged based on discussion. Quality guarantee of product after 1 year of its delivery will be waived.

14. Others

In case of any questions or opinions regarding the Specification, please have it in written manner within 45 days after issued date.

Mouser Electronics

Authorized Distributor

Click to View Pricing, Inventory, Delivery & Lifecycle Information:

[Kyocera:](#)

[ST3215SB32768H5MRXA1](#)

Компания «Life Electronics» занимается поставками электронных компонентов импортного и отечественного производства от производителей и со складов крупных дистрибьюторов Европы, Америки и Азии.

С конца 2013 года компания активно расширяет линейку поставок компонентов по направлению коаксиальный кабель, кварцевые генераторы и конденсаторы (керамические, пленочные, электролитические), за счёт заключения дистрибьюторских договоров

Мы предлагаем:

- Конкуренспособные цены и скидки постоянным клиентам.
- Специальные условия для постоянных клиентов.
- Подбор аналогов.
- Поставку компонентов в любых объемах, удовлетворяющих вашим потребностям.
- Приемлемые сроки поставки, возможна ускоренная поставка.
- Доставку товара в любую точку России и стран СНГ.
- Комплексную поставку.
- Работу по проектам и поставку образцов.
- Формирование склада под заказчика.
- Сертификаты соответствия на поставляемую продукцию (по желанию клиента).
- Тестирование поставляемой продукции.
- Поставку компонентов, требующих военную и космическую приемку.
- Входной контроль качества.
- Наличие сертификата ISO.

В составе нашей компании организован Конструкторский отдел, призванный помогать разработчикам, и инженерам.

Конструкторский отдел помогает осуществить:

- Регистрацию проекта у производителя компонентов.
- Техническую поддержку проекта.
- Защиту от снятия компонента с производства.
- Оценку стоимости проекта по компонентам.
- Изготовление тестовой платы монтаж и пусконаладочные работы.



Тел: +7 (812) 336 43 04 (многоканальный)

Email: org@lifeelectronics.ru