

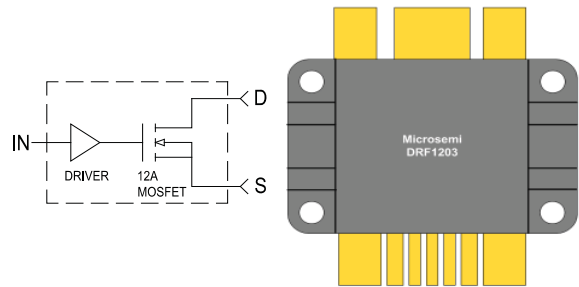

MOSFET Driver Hybrid

The DRF1203 hybrid includes a high power gate driver and the power MOSFET. The driver output can be configured as Inverting and Non-Inverting. It was designed to provide the system designer increased flexibility and lowered cost over a non-integrated solution.



FEATURES

- Switching Frequency: DC TO 30MHz
- Low Pulse Width Distortion
- Single Power Supply
- 1V CMOS Schmitt Trigger Input 1V Hysteresis
- Inverting Non-Inverting Select
- RoHS Compliant 
- Switching Speed 3-4ns
- $B_{V_{ds}} = 1Kv$
- $I_{ds} = 12A$ avg.
- $R_{ds(on)} \leq .90$ Ohm
- $P_D = 560W$

TYPICAL APPLICATIONS

- Class C, D and E RF Generators
- Switch Mode Power Amplifiers
- Pulse Generators
- Ultrasound Transducer Drivers
- Acoustic Optical Modulators

Driver Absolute Maximum Ratings

Symbol	Parameter	Ratings	Unit
V_{DD}	Supply Voltage	15	V
IN, FN	Input Single Voltages	-.7 to +5.5	
$I_{O\text{PK}}$	Output Current Peak	8	A
T_{JMAX}	Operating and Storage Temperature	175	°C

Driver Specifications

Symbol	Parameter	Min	Typ	Max	Unit
V_{DD}	Supply Voltage	10		15	V
IN	Input Voltage	3		5.5	
$IN_{(R)}$	Input Voltage Rising Edge		3		ns
$IN_{(F)}$	Input Voltage Falling Edge		3		
I_{DDQ}	Quiescent Current		2		mA
I_O	Output Current		8		A
C_{ISS}	Input Capacitance		3		
R_{IN}	Input Parallel Resistance		1		MΩ
$V_{T(ON)}$	Input, Low to High Out (See Truth Table)	0.8		1.1	V
$V_{T(OFF)}$	Input, High to Low Out (See Truth Table)	1.9		2.2	
T_{DLY}	Time Delay (throughput)		38		ns
t_r	Rise Time		5		ns
t_f	Fall Time		5		
T_D	Prop. Delay		35		

Driver Output Characteristics

DRF1203

Symbol	Parameter	Min	Typ	Max	Unit
C_{out}	Output Capacitance		2500		pF
R_{out}	Output Resistance		.8		Ω
L_{out}	Output Inductance		3		nH
F_{MAX}	Operating Frequency CL = 3000nF + 50 Ω	30			MHz
F_{MAX}	Operating Frequency RL = 50 Ω	50			

Driver Thermal Characteristics

Symbol	Parameter	Min	Typ	Max	Unit
$R_{\theta JC}$	Thermal Resistance Junction to Case		1.5		$^{\circ}\text{C}/\text{W}$
$R_{\theta JHS}$	Thermal Resistance Junction to Heat Sink		2.5		
T_{JSTG}	Storage Temperature		-55 to 150		$^{\circ}\text{C}$
P_{DJHS}	Maximum Power Dissipation @ $T_{SINK} = 25^{\circ}\text{C}$		60		W
P_{DJC}	Total Power Dissipation @ $T_C = 25^{\circ}\text{C}$		100		

MOSFET Absolute Maximum Ratings

Symbol	Parameter	Min	Typ	Max	Unit
BV_{DSS}	Drain Source Voltage	1000			V
I_D	Continuous Drain Current $T_{HS} = 25^{\circ}\text{C}$			12	A
$R_{DS(on)}$	Drain-Source On State Resistance		0.90		Ω
T_{jmax}	Operating Temperature			175	$^{\circ}\text{C}$

MOSFET Dynamic Characteristics

Symbol	Parameter	Min	Typ	Max	Unit
C_{iss}	Input Capacitance		2000		pF
C_{oss}	Output Capacitance		165		
C_{rss}	Reverse Transfer Capacitance		75		

MOSFET Thermal Characteristics

Symbol	Parameter	Min	Type	Max	Unit
$R_{\theta JC}$	Thermal Resistance Junction to Case		0.53		$^{\circ}\text{C}/\text{W}$
$R_{\theta JHS}$	Thermal Resistance Junction to Heat Sink		0.141		
T_{JSTG}	Storage Temperature		-55 to 150		$^{\circ}\text{C}$
P_{DHS}	Maximum Power Dissipation @ $T_{SINK} = 25^{\circ}\text{C}$		1060		W
P_{DC}	Total Power Dissipation @ $T_C = 25^{\circ}\text{C}$		2830		

Microsemi reserves the right to change, without notice, the specifications and information contained herein.

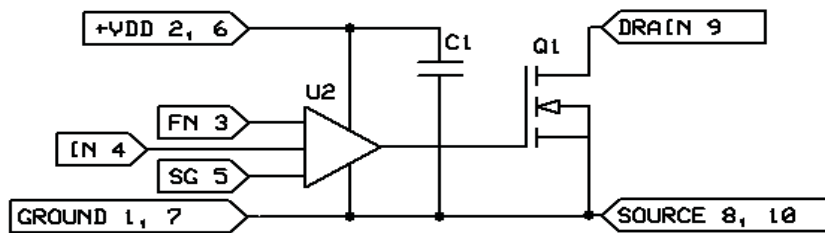

Figure 1, DRF1203 Simplified Circuit Diagram

The Simplified DRF1203 Circuit Diagram is illustrated above. By including the driver high speed by-pass capacitor (C1), their contribution to the internal parasitic loop inductance of the driver output is greatly reduced. This, coupled with the tight geometry of the hybrid, allows optimal gate drive to the MOSFET. This low parasitic approach, coupled with the Schmitt trigger input (IN), Kelvin signal ground (SG) and the Anti-Ring Function, provide improved stability and control in Kilowatt to Multi-Kilowatt, high Frequency applications. The IN pin is the input for the control signal and is applied to a Schmitt Trigger. Both the FN and IN pins are referenced to the Kelvin ground (SG.) The signal is then applied to the intermediate drivers and level shifters; this section contains proprietary circuitry designed specifically for the ring abatement. The power drivers provide high current to the gate of the MOSFETS.

The Function (FN, pin 3) is the invert or non-invert select Pin, it is Internally held high.

Truth Table *Referenced to SG		
FN (pin 3)*	IN (pin 4)*	MOSFET
HIGH	HIGH	ON
HIGH	LOW	OFF
LOW	HIGH	OFF
LOW	LOW	ON

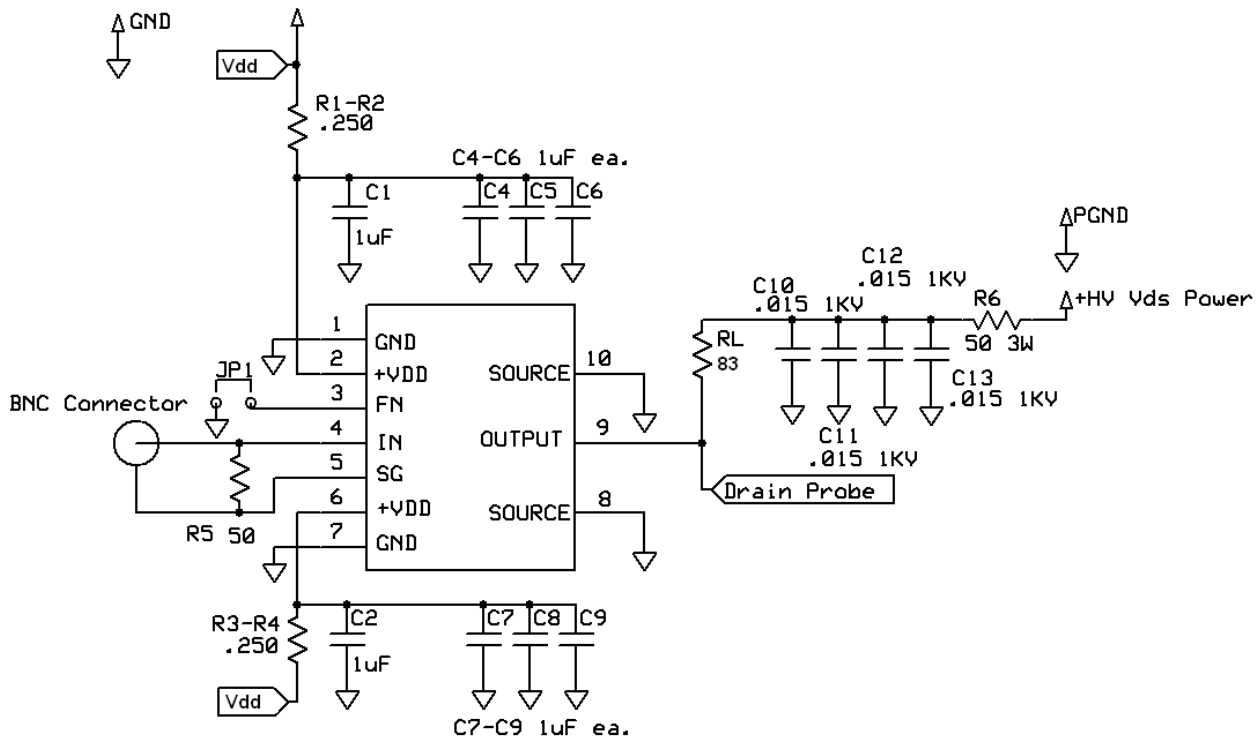
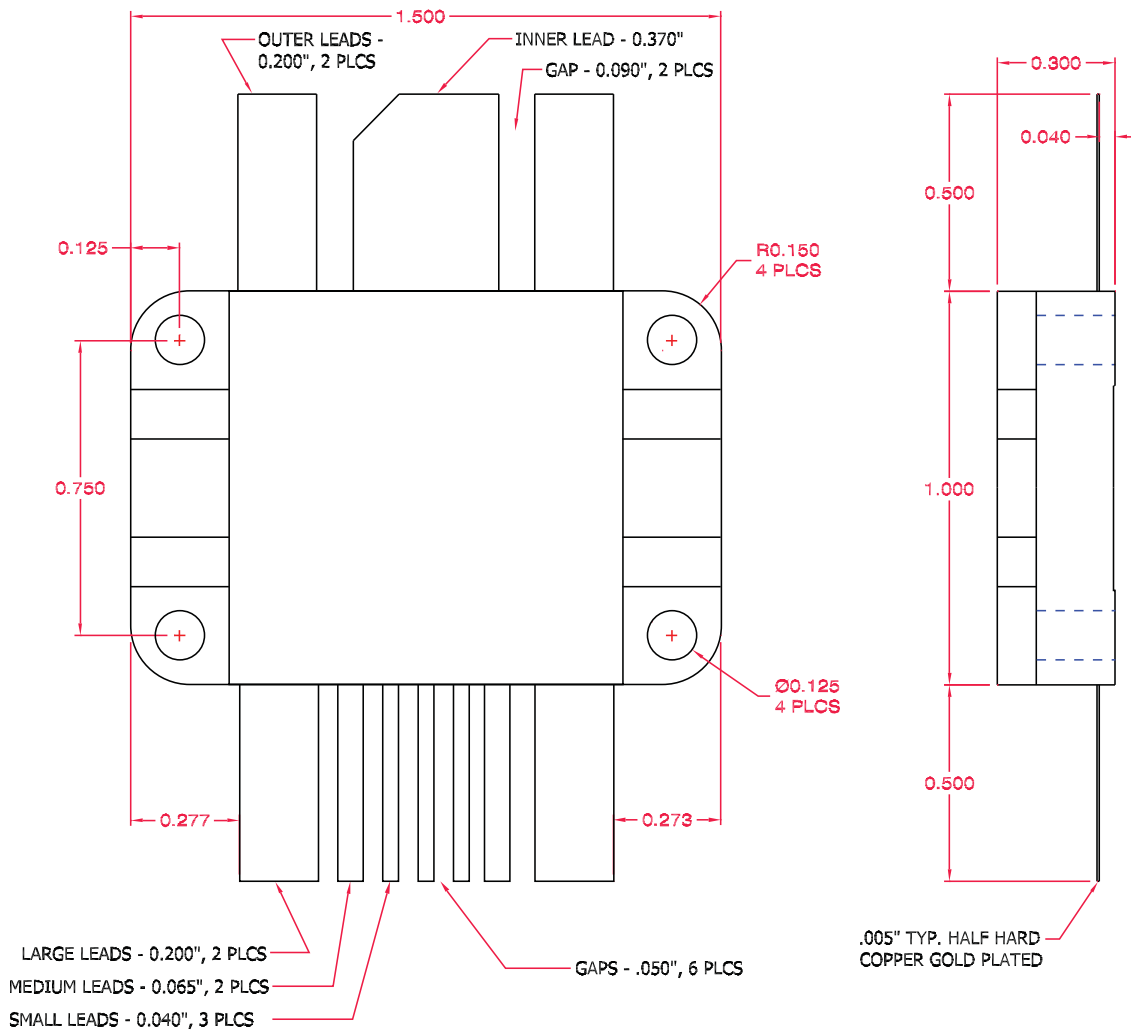

Figure 2, DRF1203 Test Circuit

The Test Circuit illustrated above was used to evaluate the DRF1203 (available as an evaluation Board DRF12XX / EVALSW.) The input control signal is applied to the DRF1203 via IN(4) and SG(5) pins using RG188. This provides excellent noise immunity and control of the signal ground currents.

The $+V_{DD}$ inputs (2,6) are by-passed (C1,C2, C4-C9), this is in addition to the internal by-passing mentioned previously. The capacitors used for this function must be capable of supporting the RMS currents and frequency of the gate load. R_L set for I_{DM} at V_{DS} max this load is used to evaluate the output performance of the DRF1203.

Pin Assignments	
Pin 1	Ground
Pin 2	+Vdd
Pin 3	FN
Pin 4	IN
Pin 5	SG
Pin 6	+Vdd
Pin 7	Ground
Pin 8	Source
Pin 9	Drain
Pin 10	Source



All dimensions are ± .005

Figure 3, DRF1203 Mechanical Outline

Компания «Life Electronics» занимается поставками электронных компонентов импортного и отечественного производства от производителей и со складов крупных дистрибьюторов Европы, Америки и Азии.

С конца 2013 года компания активно расширяет линейку поставок компонентов по направлению коаксиальный кабель, кварцевые генераторы и конденсаторы (керамические, пленочные, электролитические), за счёт заключения дистрибьюторских договоров

Мы предлагаем:

- Конкурентоспособные цены и скидки постоянным клиентам.
- Специальные условия для постоянных клиентов.
- Подбор аналогов.
- Поставку компонентов в любых объемах, удовлетворяющих вашим потребностям.
- Приемлемые сроки поставки, возможна ускоренная поставка.
- Доставку товара в любую точку России и стран СНГ.
- Комплексную поставку.
- Работу по проектам и поставку образцов.
- Формирование склада под заказчика.
- Сертификаты соответствия на поставляемую продукцию (по желанию клиента).
- Тестирование поставляемой продукции.
- Поставку компонентов, требующих военную и космическую приемку.
- Входной контроль качества.
- Наличие сертификата ISO.

В составе нашей компании организован Конструкторский отдел, призванный помогать разработчикам, и инженерам.

Конструкторский отдел помогает осуществить:

- Регистрацию проекта у производителя компонентов.
- Техническую поддержку проекта.
- Защиту от снятия компонента с производства.
- Оценку стоимости проекта по компонентам.
- Изготовление тестовой платы монтаж и пусконаладочные работы.



Тел: +7 (812) 336 43 04 (многоканальный)
Email: org@lifeelectronics.ru