



60W Passive Power over Ethernet Adapter Lowest Cost Ultra PoE Power Injector



Features

- Continuous flow of power with no detection
- Very Low leakage
- Non-Vented Case
- 2 or 3 Wire Options
- 1 Year Warranty
- Lowest Cost Ultra PoE
- Full Protection OCP, OVP
- Level VI Efficiency
- Optional Gigabit Base-T Data Rate

Applications

- Satellite Receivers
- Wireless Network Access Points
- Kiosks
- Security Camera
- LCD Displays
- WiMax Access Points

Safety Approvals

- cUL/UL
- CE

Mechanical Characteristics

- Length: 163mm (6.4in)
- Width: 65mm (2.56in)
- Height: 36mm (1.42in)
- Weight: 0.4Kg

Output Specifications

Model Number	Output Voltage	Output Current	Input Connector	Gigabit
POE61W -560D-R ¹	56V	1.1A	2 Wire C8	No
POE61W- 560DG-R ¹	56V	1.1A	2 Wire C8	Yes

Notes: (1) Consult factory for availability

Phihong is not responsible for any error, and reserves the right to make changes without notice. Please visit our website at www.phihong.com for the most up-to-date specifications and contact information.

INPUT:**AC Input Voltage Range**

90 to 264VAC

AC Input Voltage Rating

100 to 240VAC, 47-63Hz

AC Input Current

2.0A (RMS) maximum for 90VAC

1.2A (RMS) maximum for 240VAC

Leakage Current

0.25mA maximum fro 264VAC, 50Hz

AC Inrush Current

30A maximum for 115VAC

60A maximum for 230VAC

(at cold start, 25°C)

OUTPUT:**Total Output Power**

60W

Output Ripple

250mVp-p

DC Offset

No data degradation with DC imbalance 18mA

Efficiency

DOE Level VI

Hold-up Time

10mS min. 120VAC and maximum load

ENVIRONMENTAL:**Temperature**

Operation 0 to +40°C

Non-operation -20 to +65°C

Humidity 5 to 90%

EMC

Complies with FCC Class B

Complies with EN55032 Class B

Isolation TestPrimary to Secondary: 4242VDC for 1 minute,
10mAPrimary to F.G.: 2121VDC for 1 minute,
10mASecondary to F.G.: 2121VDC for 1 minute,
10mA**Immunity**

ESD: EN61000-4-2. Level 3

RS: EN61000-4-3. Level 2

EFT: EN61000-4-4. Level 2

Surge: EN61000-4-5. Level 3

CS: EN61000-4-6. Level 2

Voltage Dips EN61000-4-11

Harmonic: EN61000-3-2 Class A

Insulation Resistance

Primary to Secondary: >10M OHM 500VDC

Primary to Field Ground: >10M OHM
500VDC**FEATURE:****Over Voltage/Current, Short Circuit Protection**Outputs equipped with short circuit protection
and overload protection.The output can be shorted permanently without
damage**Input Connector**

IEC320 C8

Output Connection

4-pair powering for Gigabit models

Pins 3,6, 4,5(+) Pins 1,2, 7,8 (-)

2-pair powering for non-gigabit models

Pins 4,5(+) Pins 7,8 (-)

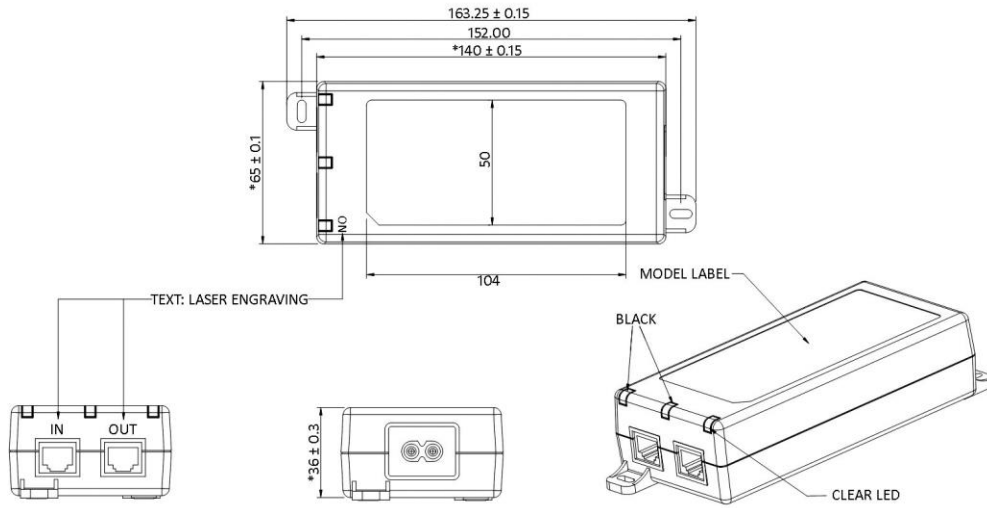

Supplier's Declaration of Conformity
47 CFR § 2.1077 Compliance Information

Phihong USA Corporation
47800 Fremont Boulevard
Fremont, CA 94538
Telephone: (510) 445-0100
www.phihong.com

NOTE: This model has/The models in this products series have been tested and found to comply with the limits for a Class B digital device, pursuant to part 15 of the FCC Rules. These limits are designed to provide reasonable protection against harmful interference in a residential installation. This equipment generates, uses and can radiate radio frequency energy and, if not installed and used in accordance with the instructions, may cause harmful interference to radio communications. However, there is no guarantee that interference will not occur in a particular installation. If this equipment does cause harmful interference to radio or television reception, which can be determined by turning the equipment off and on, the user is encouraged to try to correct the interference by one or more of the following measures:

- Reorient or relocate the receiving antenna.
- Increase the separation between the equipment and receiver.
- Connect the equipment into an outlet on a circuit different from that to which the receiver is connected.
- Consult the dealer or an experienced radio/TV technician for help.

Changes or modifications to equipment not expressly approved by PHIHONG could void the user's authority to operate the equipment.

Компания «Life Electronics» занимается поставками электронных компонентов импортного и отечественного производства от производителей и со складов крупных дистрибьюторов Европы, Америки и Азии.

С конца 2013 года компания активно расширяет линейку поставок компонентов по направлению коаксиальный кабель, кварцевые генераторы и конденсаторы (керамические, пленочные, электролитические), за счёт заключения дистрибьюторских договоров

Мы предлагаем:

- Конкурентоспособные цены и скидки постоянным клиентам.
- Специальные условия для постоянных клиентов.
- Подбор аналогов.
- Поставку компонентов в любых объемах, удовлетворяющих вашим потребностям.
- Приемлемые сроки поставки, возможна ускоренная поставка.
- Доставку товара в любую точку России и стран СНГ.
- Комплексную поставку.
- Работу по проектам и поставку образцов.
- Формирование склада под заказчика.
- Сертификаты соответствия на поставляемую продукцию (по желанию клиента).
- Тестирование поставляемой продукции.
- Поставку компонентов, требующих военную и космическую приемку.
- Входной контроль качества.
- Наличие сертификата ISO.

В составе нашей компании организован Конструкторский отдел, призванный помогать разработчикам, и инженерам.

Конструкторский отдел помогает осуществить:

- Регистрацию проекта у производителя компонентов.
- Техническую поддержку проекта.
- Защиту от снятия компонента с производства.
- Оценку стоимости проекта по компонентам.
- Изготовление тестовой платы монтаж и пусконаладочные работы.



Тел: +7 (812) 336 43 04 (многоканальный)

Email: org@lifeelectronics.ru