

LED DISPLAY**LTS-4817CKG-P**
DATA SHEET

<u>ITEM</u>	<u>Description</u>	<u>By</u>	<u>DATE</u>
1	New Spec	Reo Lin	2011/04/01
2	Add Luminous Intensity range for 1 mA	Reo Lin	2011/08/01
3	Modify PACKAGE DIMENSIONS AND RECOMMENDED SOLDERING PATTERN	Reo Lin	2011/08/10

FEATURES

- * 0.39 inch (10.0 mm) DIGIT HEIGHT
- * CONTINUOUS UNIFORM SEGMENTS
- * LOW POWER REQUIREMENT
- * EXCELLENT CHARACTERS APPEARANCE
- * HIGH BRIGHTNESS & HIGH CONTRAST
- * WIDE VIEWING ANGLE
- * SOLID STATE RELIABILITY
- * CATEGORIZED FOR LUMINOUS INTENSITY
- * SMD DISPLAY
- * **LEAD FREE PACKAGE (ACCORDING TO ROHS)**

DESCRIPTION

The LTS-4817CKG-P is a 0.39 inch (10.0 mm) digit height single digit SMD display. The devices utilize AlInGaP Green LED chips, which are made from AlInGaP on a non-transparent GaAs substrate. The display has Gray face and white segments, and suitable for reverse mount assembly.

DEVICE

PART NO.	DESCRIPTION
AlInGaP green	Common Anode
LTS-4817CKG-P	

PACKAGE DIMENSIONS

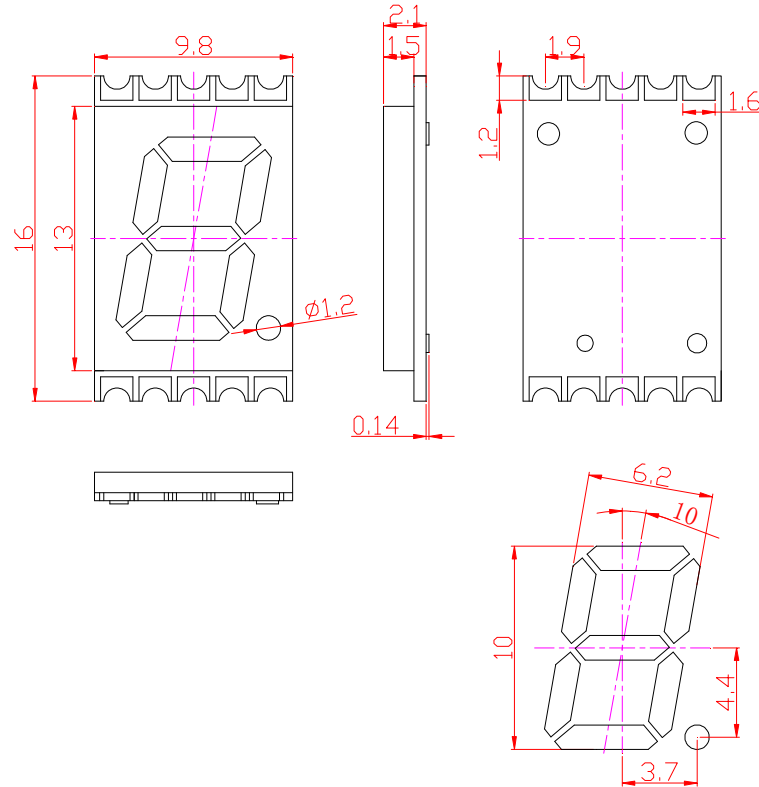

Solder Pad Vs Painting Diagram

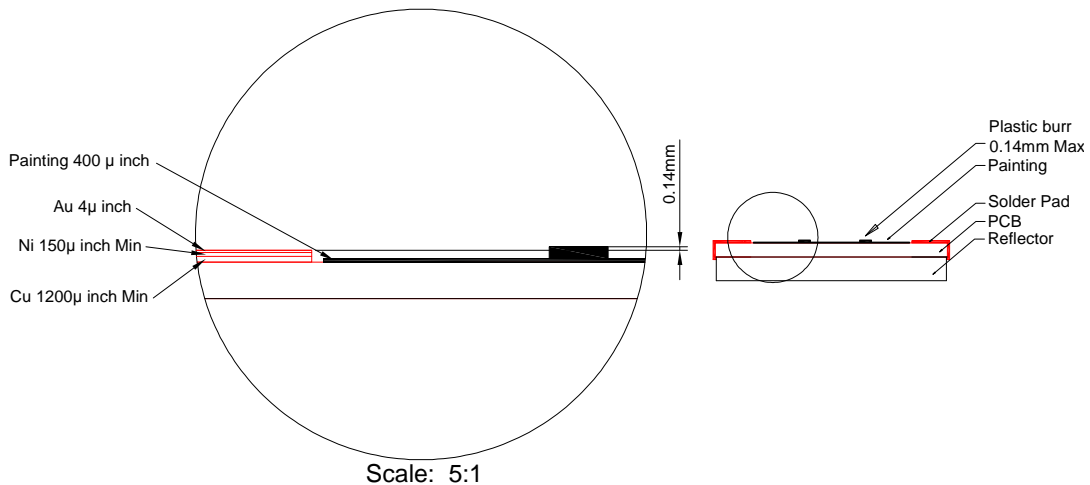

NOTES:

1. Plastic pins' burr max. 0.14 mm,
2. All dimensions are in millimeters. Tolerances are $\pm 0.25\text{mm}$ (0.01") unless otherwise noted.
3. Solder pad materials and thickness: Cu: $1200\ \mu\text{inch}$ Ni: Min $150\ \mu\text{inch}$ Au: $4\ \mu\text{inch}$.

INTERNAL CIRCUIT DIAGRAM

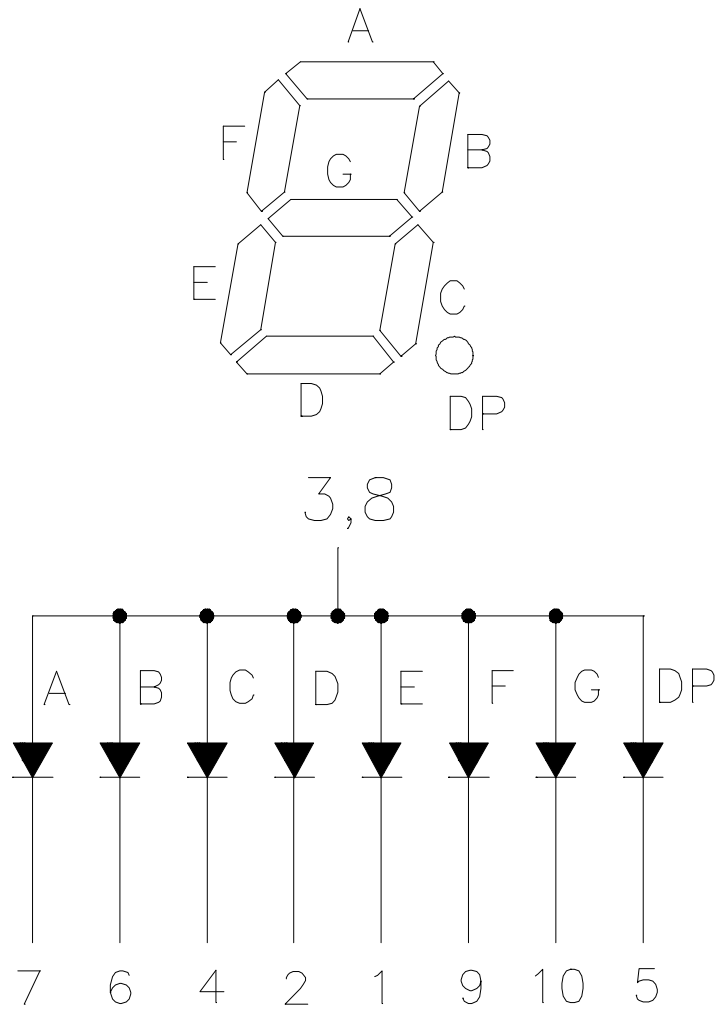

PIN CONNECTION

No.	CONNECTION
1	CATHODE E
2	CATHODE D
3	COMMON ANODE
4	CATHODE C
5	CATHODE D.P.
6	CATHODE B
7	CATHODE A
8	COMMON ANODE
9	CATHODE F
10	CATHODE G

ABSOLUTE MAXIMUM RATING AT Ta = 25°C

PARAMETER	MAXIMUM RATING	UNIT
Power Dissipation Per Segment	70	mW
Peak Forward Current Per Segment (Frequency 1Khz,10% duty cycle)	60	mA
Continuous Forward Current Per Segment	25	mA
Forward Current Derating from 25°C	0.28	mA/°C
Operating Temperature Range	-40°C to +105°C	
Storage Temperature Range	-40°C to +105°C	
Iron Soldering Conditions: 1/16 inch Below Seating Plane for 3 Seconds at 260°C		

ELECTRICAL / OPTICAL CHARACTERISTICS AT Ta = 25°C

PARAMETER	SYMBOL	MIN.	TYP.	MAX.	UNIT	TEST CONDITION
Average Luminous Intensity	I _v	160	500		μ cd	I _F = 1mA
Peak Emission Wavelength	λ _p		571		nm	I _F = 20mA
Spectral Line Half-Width	Δλ		15		nm	I _F = 20mA
Dominant Wavelength	λ _d		572		nm	I _F = 20mA
Forward Voltage Per Segment	V _F		2.05	2.6	V	I _F = 20mA
Reverse Current Per Segment ⁽²⁾	I _R			100	uA	V _R = 5V
Luminous Intensity Matching Ratio	I _v -m			2:1		I _F = 1mA

Note:

- Luminous intensity is measured with a light sensor and filter combination that approximates the CIE (Commision Internationale De L'Eclairage) eye-response curve.
- Reverse voltage is only for IR test. It can not continue to operate at this situation.

TYPICAL ELECTRICAL / OPTICAL CHARACTERISTIC CURVES

(25°C Ambient Temperature Unless Otherwise Noted)

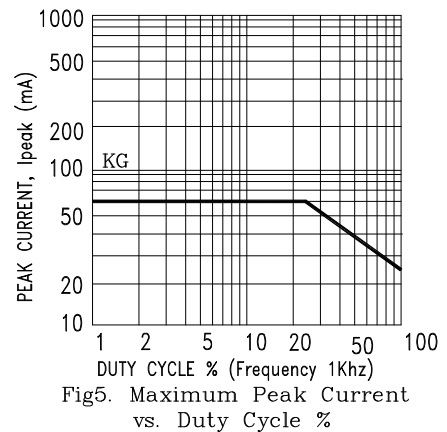
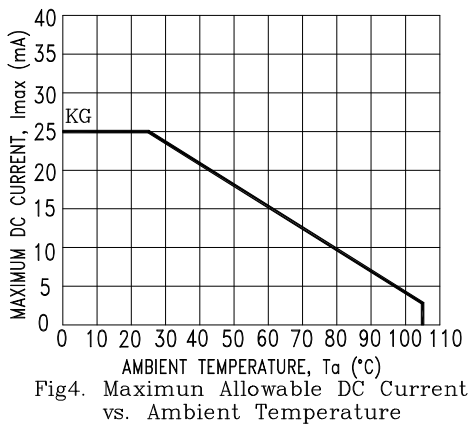
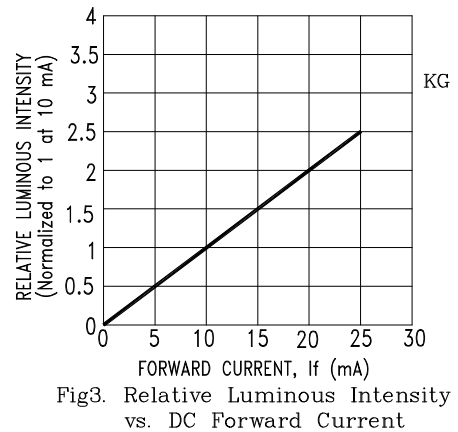
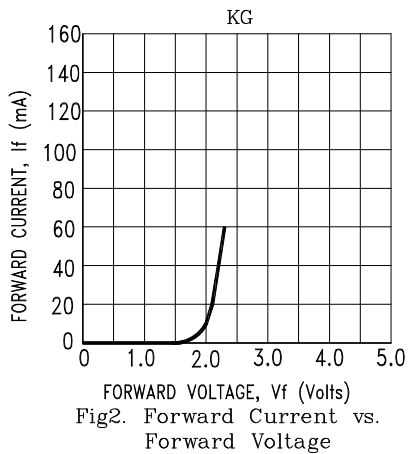
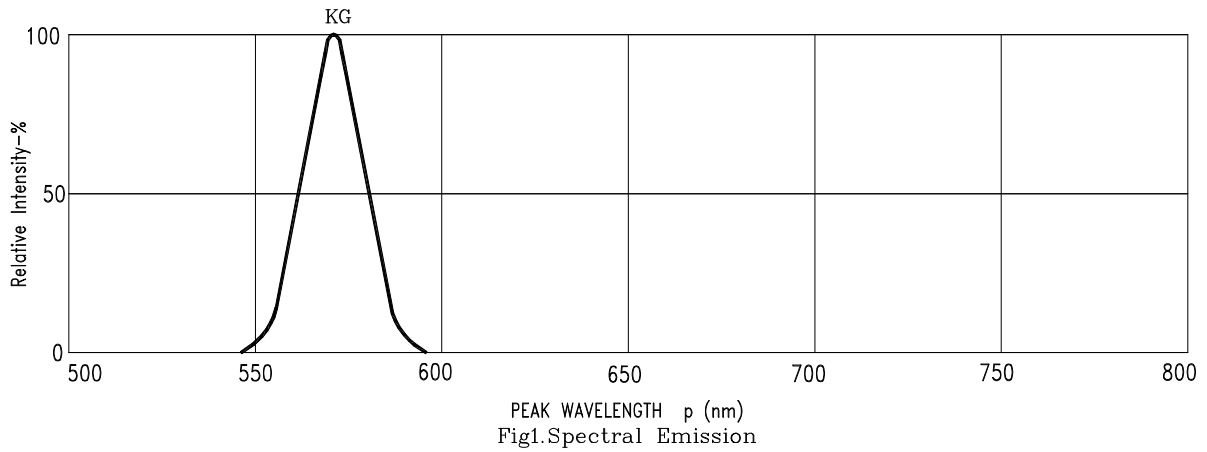

NOTE : KG=AlInGaP Green

SMT SOLDERING INSTRUCTION

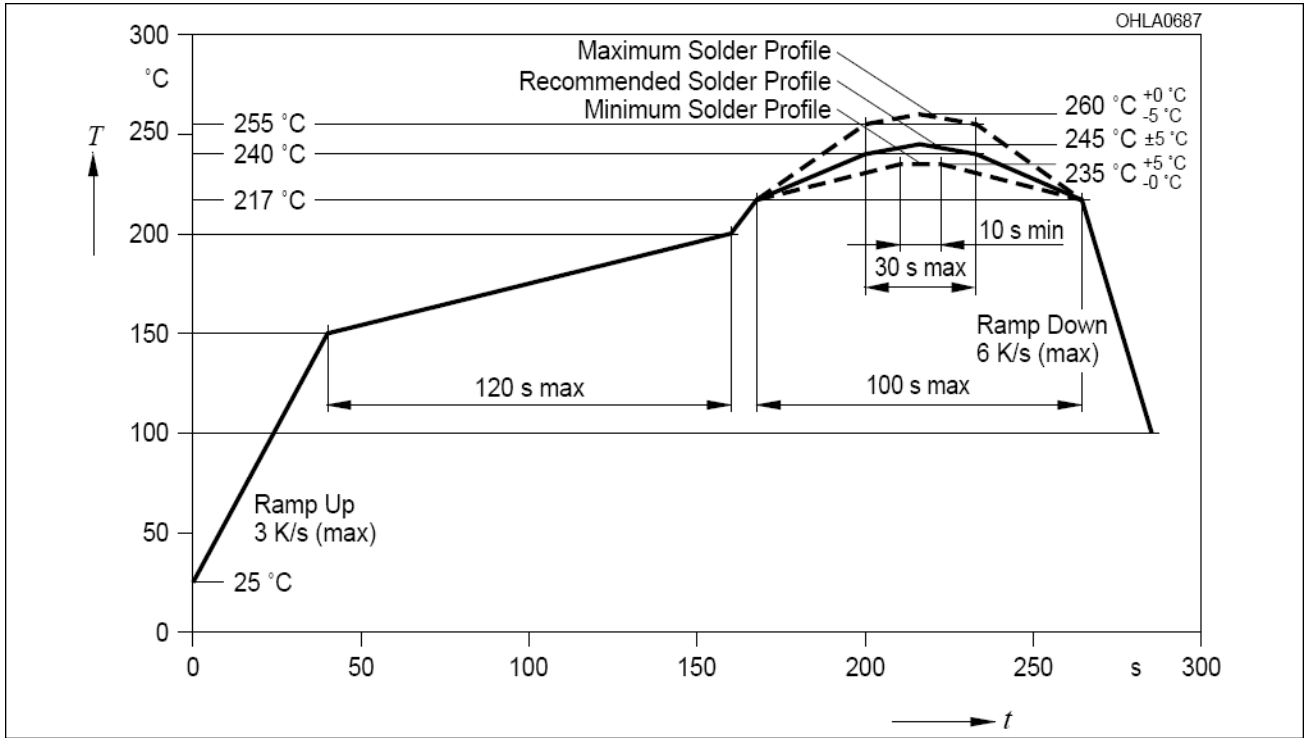

Note:

1. Recommended soldering condition:

Reflow Soldering (Two times only)		Soldering Iron (One time only)	
Pre-heat:	120~150°C.	Temperature	300°C Max.
Pre-heat time:	120sec. Max.	Soldering time	3sec. Max.
Peak temperature:	260°C Max.		
Soldering time:	5sec. Max.		

2. Number of reflow process shall be less than 2 times, and cooling process to normal temperature is required between the first and the second soldering process.

RECOMMENDED SOLDERING PATTERN

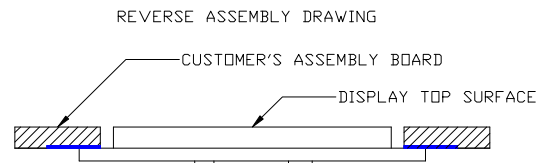
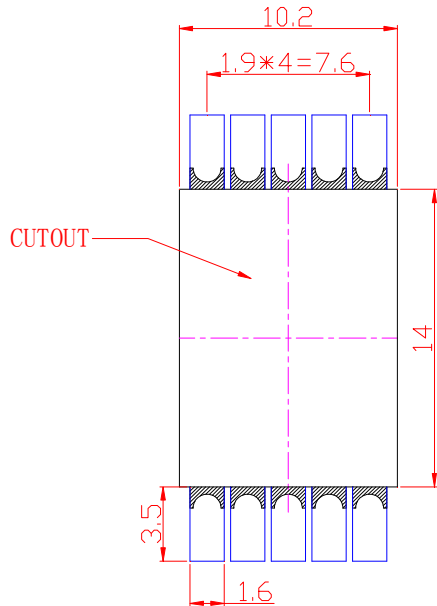

Note: All dimensions are in millimeters.

PACKING REEL DIMENSIONS

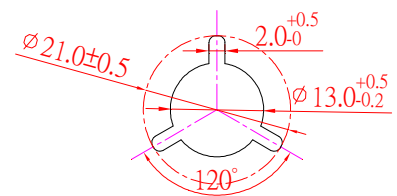
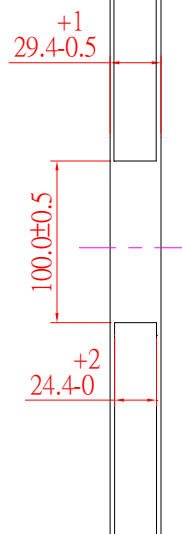
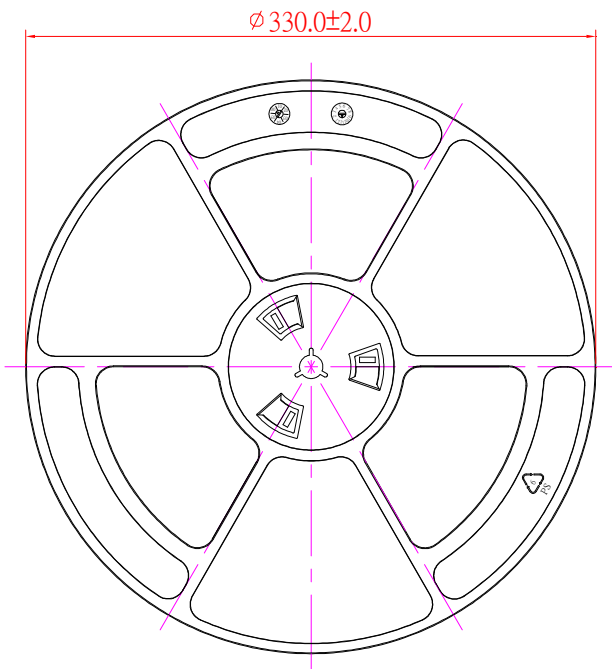

PACKING CARRIER DIMENSIONS

1. Taping parts:

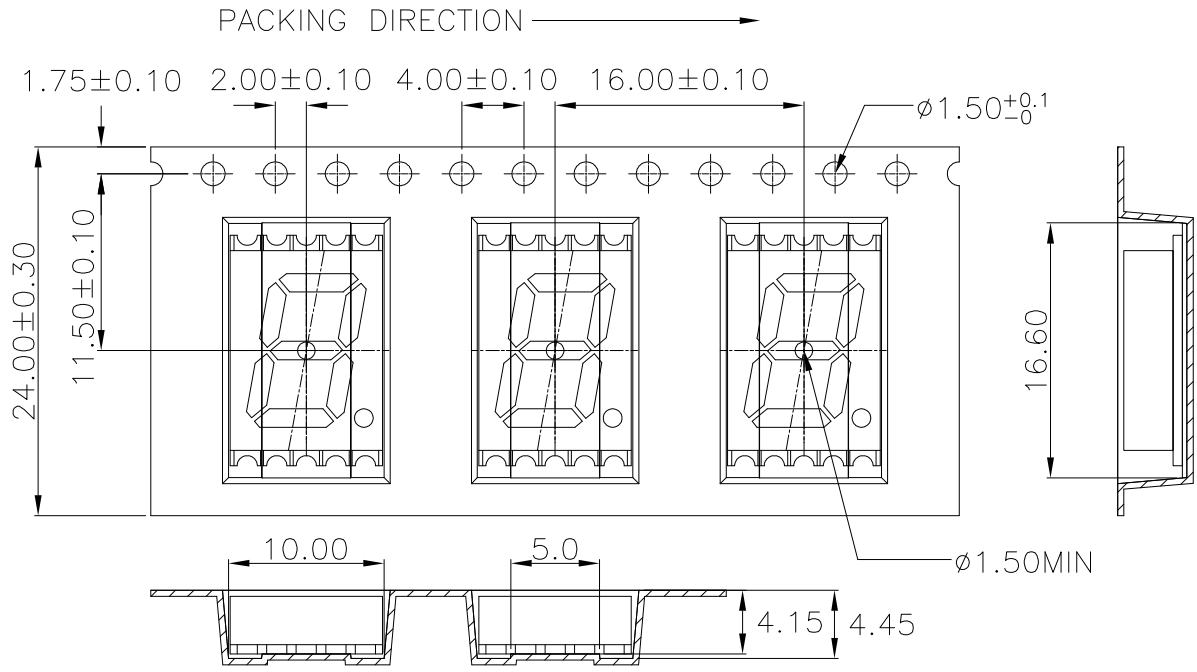

10 sprocket hole pitch cumulative tolerance ±0.20.
 Carrier camber is within 1 mm in 250 mm.
 Thickness : 0.40±0.05mm.
 All dimensions meet EIA-481-C requirements.

2. Trailer part/ Leader part:

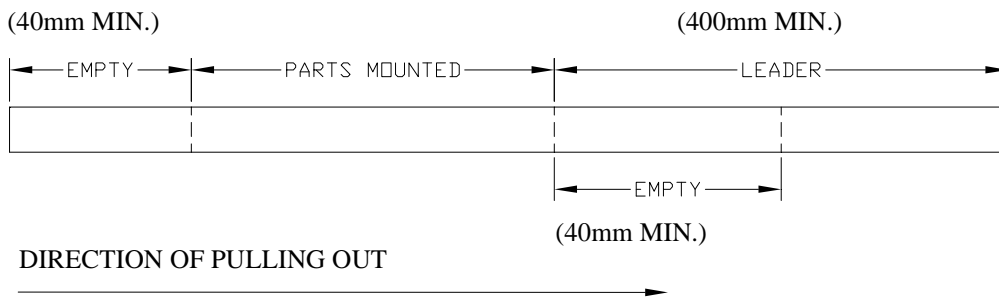

Moisture Proof Packaging

All N/D SMD displays are shipped in moisture proof package. The displays should be stored at 30°C or less and 90% RH or less. Once the package opened, moisture absorption begins.

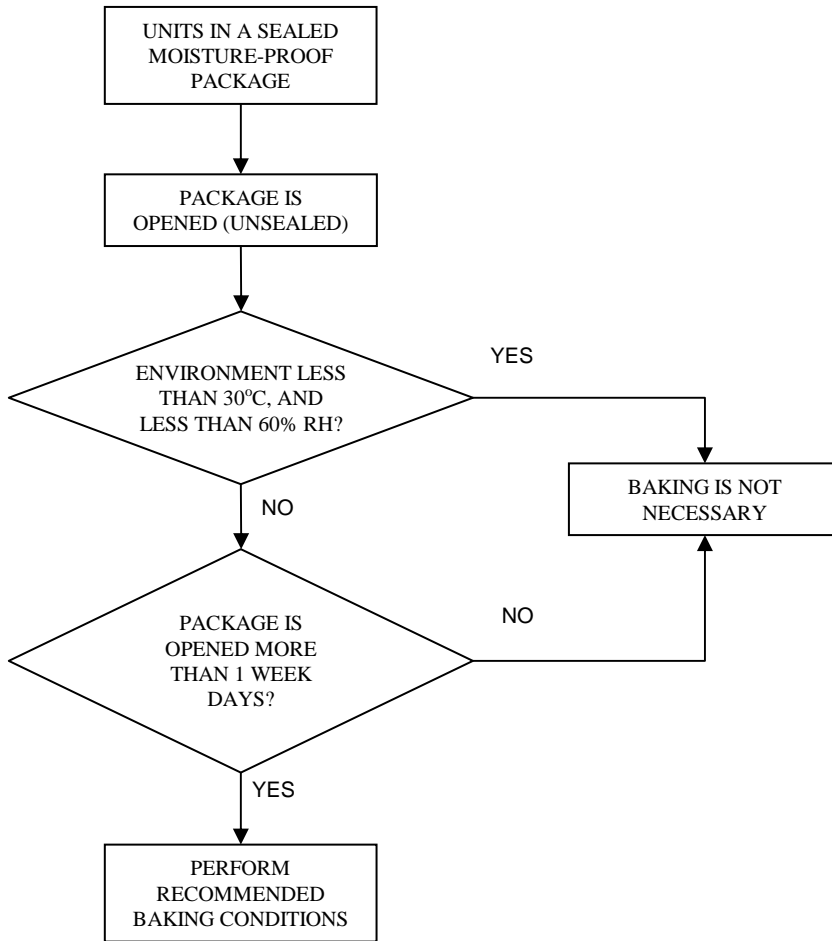

Baking Conditions

If the parts are not stored in dry conditions, they must be baked before reflow to prevent damage to the parts.

Package	Temperature	Time
In Reel	60 °C	≥ 48hours
In Bulk	100 °C	≥ 4hours
	125 °C	≥ 2hours

Baking should only be done once.

Компания «Life Electronics» занимается поставками электронных компонентов импортного и отечественного производства от производителей и со складов крупных дистрибьюторов Европы, Америки и Азии.

С конца 2013 года компания активно расширяет линейку поставок компонентов по направлению коаксиальный кабель, кварцевые генераторы и конденсаторы (керамические, пленочные, электролитические), за счёт заключения дистрибьюторских договоров

Мы предлагаем:

- Конкурентоспособные цены и скидки постоянным клиентам.
- Специальные условия для постоянных клиентов.
- Подбор аналогов.
- Поставку компонентов в любых объемах, удовлетворяющих вашим потребностям.
- Приемлемые сроки поставки, возможна ускоренная поставка.
- Доставку товара в любую точку России и стран СНГ.
- Комплексную поставку.
- Работу по проектам и поставку образцов.
- Формирование склада под заказчика.
- Сертификаты соответствия на поставляемую продукцию (по желанию клиента).
- Тестирование поставляемой продукции.
- Поставку компонентов, требующих военную и космическую приемку.
- Входной контроль качества.
- Наличие сертификата ISO.

В составе нашей компании организован Конструкторский отдел, призванный помогать разработчикам, и инженерам.

Конструкторский отдел помогает осуществить:

- Регистрацию проекта у производителя компонентов.
- Техническую поддержку проекта.
- Защиту от снятия компонента с производства.
- Оценку стоимости проекта по компонентам.
- Изготовление тестовой платы монтаж и пусконаладочные работы.



Тел: +7 (812) 336 43 04 (многоканальный)

Email: org@lifeelectronics.ru