

ARF446G

ARF447G

*G Denotes RoHS Compliant,
Pb Free Terminal Finish

RF POWER MOSFETs

N-CHANNEL ENHANCEMENT MODE

250V 140W 65MHz

The ARF446 and ARF447 comprise a symmetric pair of common source RF power transistors designed for push-pull scientific, commercial, medical and industrial RF power amplifier applications up to 65MHz.

- **Specified 250 Volt, 40.68 MHz Characteristics:**
 - Output Power = 140 Watts.**
 - Gain = 15dB (Class C)**
 - Efficiency = 75%**
- **Low Cost Common Source RF Package.**
- **Very High Breakdown for Improved Ruggedness.**
- **Low Thermal Resistance.**
- **Nitride Passivated Die for Improved Reliability.**

MAXIMUM RATINGS

All Ratings: $T_C = 25^\circ\text{C}$ unless otherwise specified.

Symbol	Parameter	ARF446G/447G	UNIT
V_{DSS}	Drain-Source Voltage	900	Volts
V_{DGO}	Drain-Gate Voltage	900	
I_D	Continuous Drain Current @ $T_C = 25^\circ\text{C}$	6.5	Amps
V_{GS}	Gate-Source Voltage	± 30	Volts
P_D	Total Power Dissipation @ $T_C = 25^\circ\text{C}$	230	Watts
$R_{\theta JC}$	Junction to Case	0.55	$^\circ\text{C/W}$
T_J, T_{STG}	Operating and Storage Junction Temperature Range	-55 to 150	$^\circ\text{C}$
T_L	Lead Temperature: 0.063" from Case for 10 Sec.	300	

STATIC ELECTRICAL CHARACTERISTICS

Symbol	Characteristic / Test Conditions	MIN	TYP	MAX	UNIT
BV_{DSS}	Drain-Source Breakdown Voltage ($V_{GS} = 0V, I_D = 250 \mu\text{A}$)	900			Volts
$V_{DS(ON)}$	On State Drain Voltage ^① ($I_D(ON) = 3.5A, V_{GS} = 10V$)			7	
I_{DSS}	Zero Gate Voltage Drain Current ($V_{DS} = V_{DSS}, V_{GS} = 0V$)			25	μA
	Zero Gate Voltage Drain Current ($V_{DS} = 0.8 V_{DSS}, V_{GS} = 0V, T_C = 125^\circ\text{C}$)			250	
I_{GSS}	Gate-Source Leakage Current ($V_{GS} = \pm 30V, V_{DS} = 0V$)			± 100	nA
g_{fs}	Forward Transconductance ($V_{DS} = 25V, I_D = 3.5A$)	4	5.7		mhos
$V_{GS(TH)}$	Gate Threshold Voltage ($V_{DS} = V_{GS}, I_D = 50mA$)	2		5	Volts

 **CAUTION:** These Devices are Sensitive to Electrostatic Discharge. Proper Handling Procedures Should Be Followed.

Microsemi Website - <http://www.microsemi.com>

DYNAMIC CHARACTERISTICS

ARF446G/447G

Symbol	Characteristic	Test Conditions	MIN	TYP	MAX	UNIT
C_{iss}	Input Capacitance	$V_{GS} = 0V$ $V_{DS} = 300V$ $f = 1\text{ MHz}$		1500	1800	pF
C_{oss}	Output Capacitance			70	130	
C_{rss}	Reverse Transfer Capacitance			27	50	
$t_{d(on)}$	Turn-on Delay Time	$V_{GS} = 15V$ $V_{DD} = 0.5 V_{DSS}$ $I_D = I_{D[Cont.]} @ 25^\circ C$ $R_G = 1.6\Omega$		7	15	ns
t_r	Rise Time			5	10	
$t_{d(off)}$	Turn-off Delay Time			23	40	
t_f	Fall Time			12	25	

FUNCTIONAL CHARACTERISTICS

Symbol	Characteristic	Test Conditions	MIN	TYP	MAX	UNIT
G_{PS}	Common Source Amplifier Power Gain	$f = 27.12\text{ MHz}$		20		dB
η	Drain Efficiency	$V_{GS} = 0V$ $V_{DD} = 300V$		80		%
Ψ	Electrical Ruggedness VSWR 20:1	$P_{out} = 140W$	No Degradation in Output Power			
G_{PS}	Common Source Amplifier Power Gain	$f = 40.68\text{ MHz}$	13	15		dB
η	Drain Efficiency	$V_{GS} = 0V$ $V_{DD} = 250V$	70	75		%
Ψ	Electrical Ruggedness VSWR 20:1	$P_{out} = 140W$	No Degradation in Output Power			

① Pulse Test: Pulse width < 380 nS, Duty Cycle < 2%

Microsemi Reserves the right to change, without notice, the specifications and information contained herein.

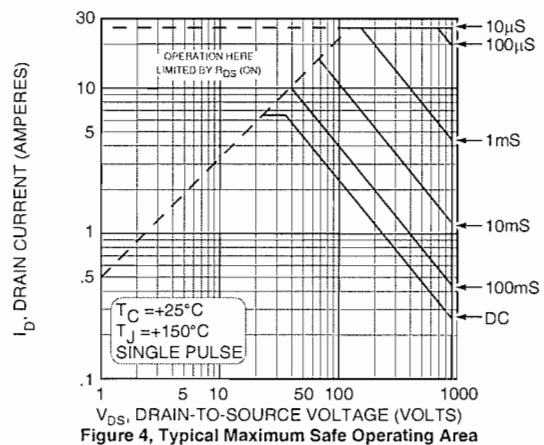
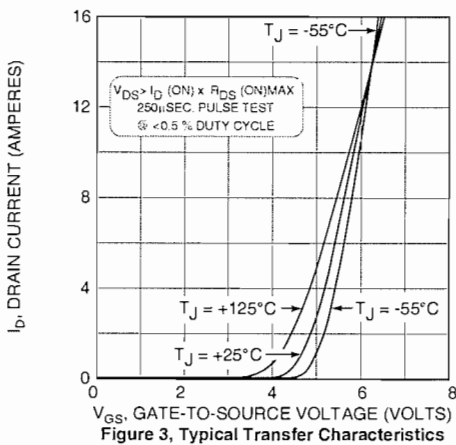
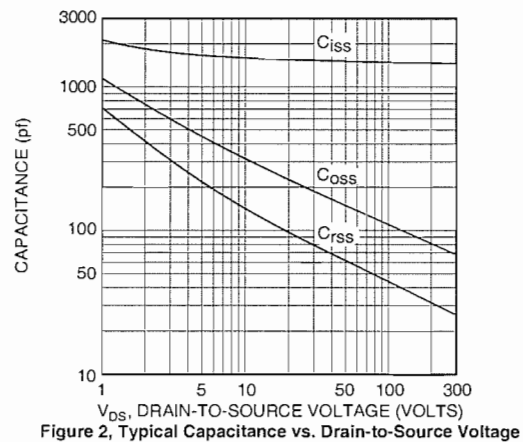
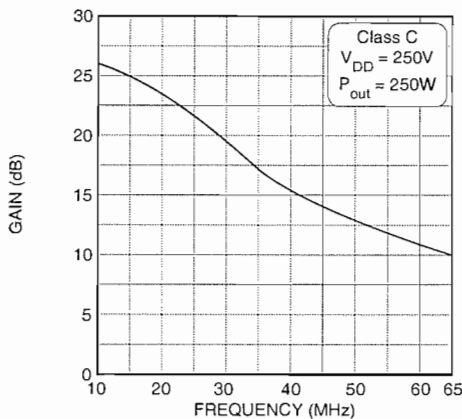

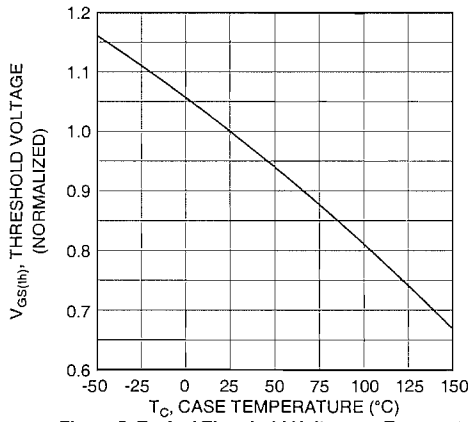

Figure 5, Typical Threshold Voltage vs Temperature

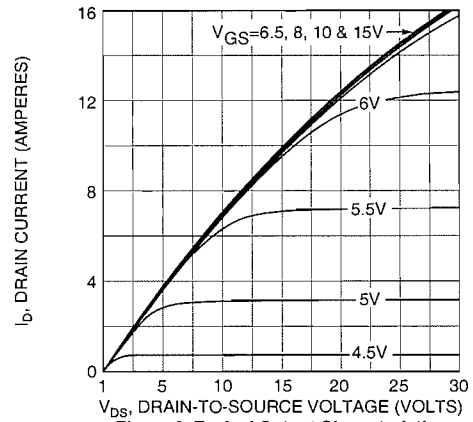

Figure 6, Typical Output Characteristics

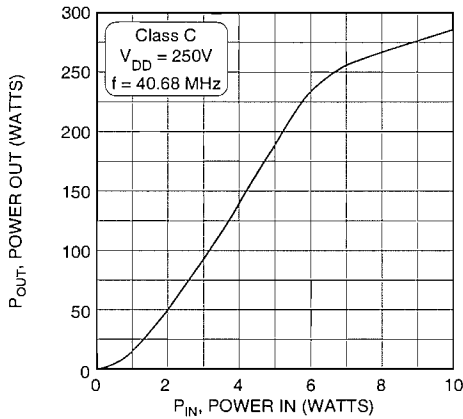

Figure 7, Typical Power Out vs Power In

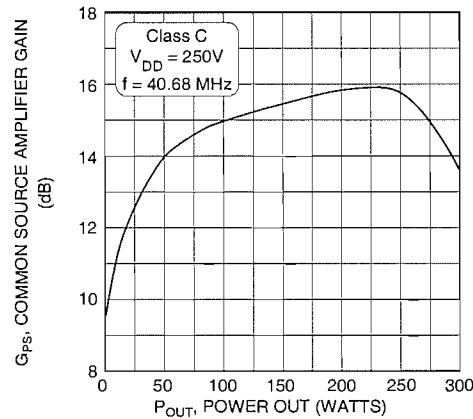

Figure 8, Typical Common Source Amplifier Gain vs Power Out

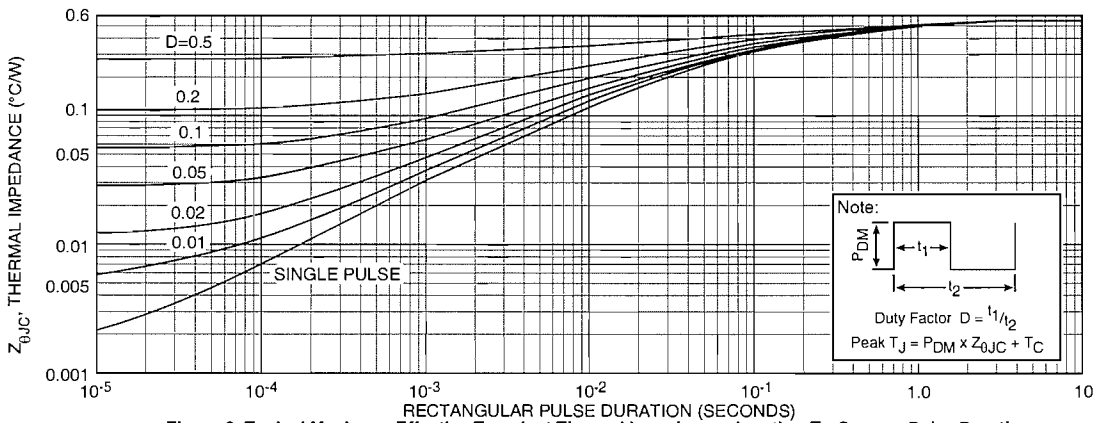

Figure 9, Typical Maximum Effective Transient Thermal Impedance, Junction-To-Case vs Pulse Duration

Table 1 - Typical Class C Large Signal Input-Output Impedance

Freq. (MHz)	Z _{in} (Ω)	Z _{oL} (Ω)
2.0	20.40 - j 9.6	142.0 - j 20
13.5	2.10 - j 6.4	73.0 - j 71
27.0	0.50 - j 2.3	30.0 - j 57
40.0	0.30 - j 0.4	15.0 - j 42
65.0	0.46 + j 2.0	6.2 - j 25

Z_{in} - gate shunted by 25Ω

Z_{oL} - conjugate of optimum load impedance for 250W at 250V

40.68 MHz Test Circuit

Parts List

- C1-C3 -- Arco 465 or equivalent
- C4-C6 -- 1nF 500V COG chip
- L1 -- 2t #18 AWG .25" ID
- L2 -- 3t #18 AWG .25" ID
- L3 -- 8t #18 AWG .25" ID
- L4 -- VK200-4B ferrite choke 3μH
- R1 -- 25 Ohm 1/2W Carbon
- T1 -- 4:1 Broadband Transformer

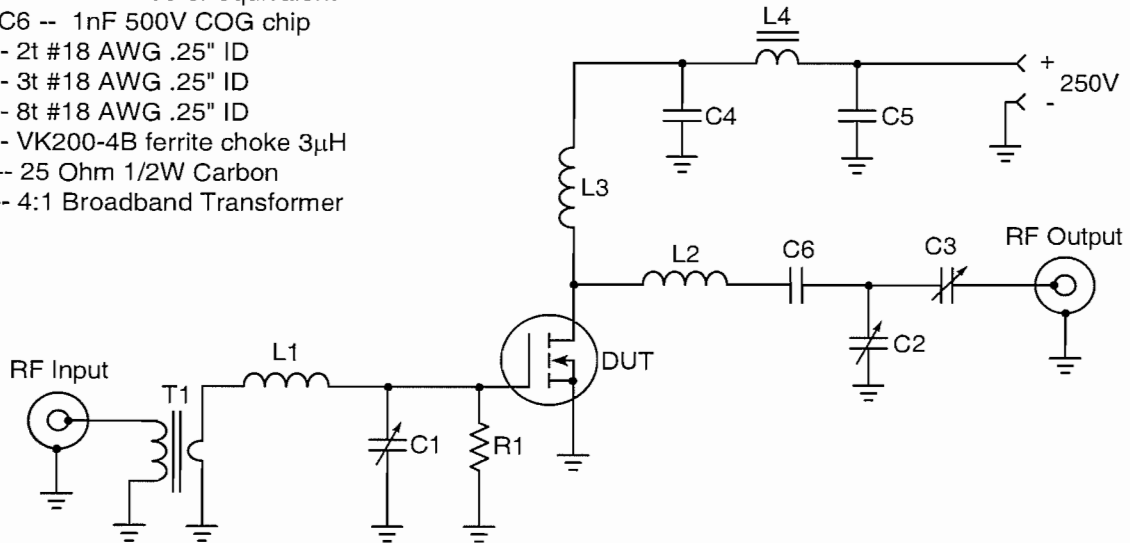

TO-247 Package Outline

ⓔ1 SAC: Tin, Silver, Copper

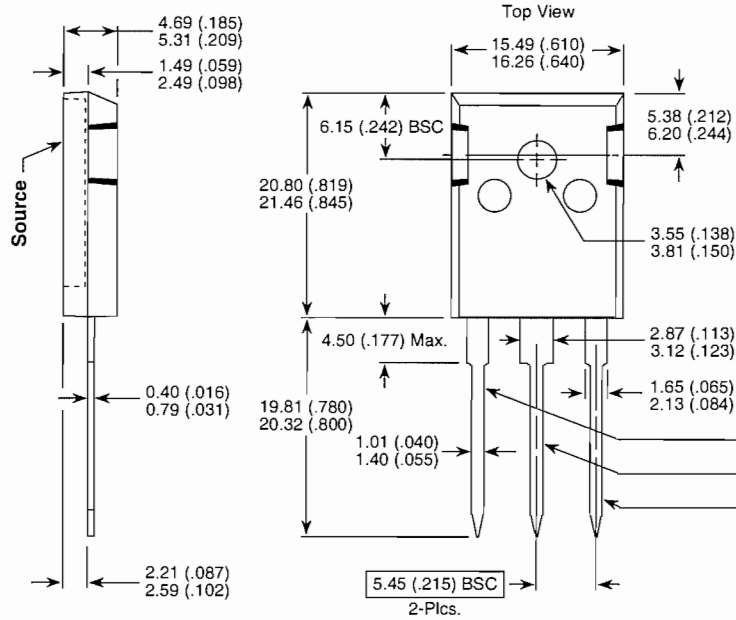

Dimensions in Millimeters and (Inches)
NOTE: The ARF446G and ARF447G Gcomprise a symmetric pair of RF power transistors and meet the same electrical specifications. The device pin-outs are the mirror image of each other to allow ease of use as a push-pull pair.

Device	
ARF446G	ARF447G
Gate	Drain
Source	Source
Drain	Gate

Компания «Life Electronics» занимается поставками электронных компонентов импортного и отечественного производства от производителей и со складов крупных дистрибьюторов Европы, Америки и Азии.

С конца 2013 года компания активно расширяет линейку поставок компонентов по направлению коаксиальный кабель, кварцевые генераторы и конденсаторы (керамические, пленочные, электролитические), за счёт заключения дистрибьюторских договоров

Мы предлагаем:

- Конкурентоспособные цены и скидки постоянным клиентам.
- Специальные условия для постоянных клиентов.
- Подбор аналогов.
- Поставку компонентов в любых объемах, удовлетворяющих вашим потребностям.
- Приемлемые сроки поставки, возможна ускоренная поставка.
- Доставку товара в любую точку России и стран СНГ.
- Комплексную поставку.
- Работу по проектам и поставку образцов.
- Формирование склада под заказчика.
- Сертификаты соответствия на поставляемую продукцию (по желанию клиента).
- Тестирование поставляемой продукции.
- Поставку компонентов, требующих военную и космическую приемку.
- Входной контроль качества.
- Наличие сертификата ISO.

В составе нашей компании организован Конструкторский отдел, призванный помогать разработчикам, и инженерам.

Конструкторский отдел помогает осуществить:

- Регистрацию проекта у производителя компонентов.
- Техническую поддержку проекта.
- Защиту от снятия компонента с производства.
- Оценку стоимости проекта по компонентам.
- Изготовление тестовой платы монтаж и пусконаладочные работы.



Тел: +7 (812) 336 43 04 (многоканальный)

Email: org@lifeelectronics.ru