

Rabbit® SBC BL2100 Series

Single-Board Computer

A high-performance single-board computer designed for medium-scale industrial control and monitoring applications.



Overview

The BL2100 series is available in four flexible configurations, which feature 40 digital I/O, 3 RS-232/485 serial ports, and a battery-backup for the real-time clock and SRAM for protected data. In addition, the BL2100 and BL2120 models include 11 channels of 12-bit resolution A/D input and 4 channels of 12-bit D/A output. The BL2100's 16 digital outputs can sink/source up to 200 mA and are configurable in Dynamic C, an easy-to-use C environment.

An optional 7-key 122 x 32 graphic display is available as a cost-effective user interface (a panel-mount, water-resistant NEMA 4 version is also available). The BL2100 boards come standard with screw terminals which, can support 14 AWG wiring or other options such as IDC or friction lock headers.

Application Highlight

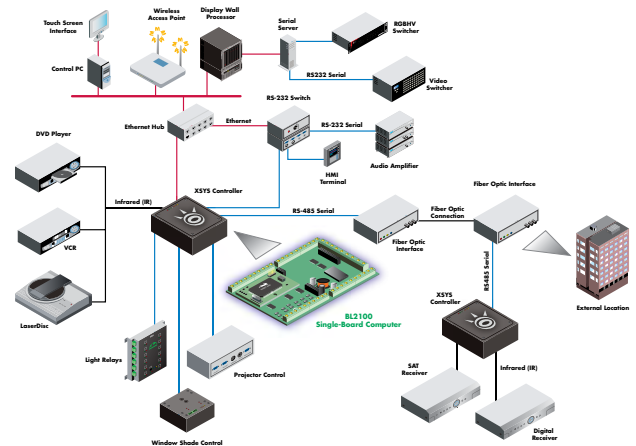

Features/Benefits

- 40 sinking/sourcing digital I/O
- Up to 512K Flash for program and up to 512K SRAM for data
- 16 digital outputs which can sink/source 200 mA
- 11 A/D and 4 D/A with 12-bit resolution
- Up to 4 serial ports: two 3-wire (or one 5-wire) RS-232 and 1 RS-485
- Royalty-free TCP/IP stack

Related Products



Dynamic C



Keypad

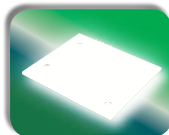

Serial Flash



Digi Connect® WAN 3G



Programming Cable



Specifications	BL2100	BL2110	BL2120	BL2130
Features				
Microprocessor	Rabbit 2000 at 22.1 MHz			
Ethernet Port	10Base-T, RJ-45, link and activity LEDs		None	
Flash	256K (standard)		256K	
SRAM	128K (standard)		128K	
Backup Battery	Socketed 3V lithium coin-type, 265 mA.h, supports RTC and SRAM			
Keypad/Display	See keypad/display option (below) and our "OP" products (for serial display options)			
Digital Inputs	24: protected to ± 36 VDC			
Digital Outputs	16: source/sink 200 mA each, 36VDC max.			
Analog Inputs	11 at 1 M Ω , 12-bit resolution, ± 10 VDC, up to 4,100 samples/sec.	None	11 at 1 M Ω , 12-bit resolution, ± 10 VDC, up to 4,100 samples/sec.	None
Analog Outputs	Four 12-bit resolution, 0-10VDC*, update rate 12 kHz	None	Four 12-bit resolution, 0-10VDC*, update rate 12 kHz	None
Serial Ports	4 total: two 3-wire (or one 5-wire) RS-232, 1 RS-485, and one 5V CMOS-compatible (programming)			
Serial Rate	Max. burst rate = CLK/32; Max. sustained rate = burst/2			
Connectors	Screw terminals support max. 14 AWG/1.5 mm ² (standard)			
Real-Time Clock	Yes			
Timers	Five 8-bit timers (four cascadable from the first) and one 10-bit timer with 2 match registers			
Watchdog Timer/Supervisor	Yes			
Power	9-36VDC, 1.5W max. (without display), 3W max. (with display)			
Operating Temperature	-40° C to +70° C			
Humidity	5-95%, non-condensing			
Board Size	4.14" x 3.41" x 0.93"; (105 mm x 87 mm x 24 mm)			
Pricing				
Price (Qty. 1)	\$339	\$249	\$299	\$209
Part Number	20-101-0461	20-101-0462	20-101-0463	20-101-0464

Keypad/Display Option	
Features	
LCD Panel	122 x 32 graphic LCD in two stacked sections (with programmable backlight); Relegendable keypad with 7-key/7-LED interface
LEDs	7 user-programmable: 1 red, 4 green, 2 yellow
Operating Temperature	0° C to 50° C
Board Size	3.00" x 2.6" x 0.75"; (76 mm x 66 mm x 19 mm)
Enclosure Size	5.60" x 4.875" x 1.5"; (142 mm x 124 mm x 38 mm)
Part Number	101-0502

You can purchase with confidence knowing that Digi is always available to serve you with expert technical support and our industry leading warranty. For detailed information visit www.digi.com/support

91001660
B2/415

Digi International
Worldwide HQ
877-912-3444
952-912-3444
www.digi.com

Digi International
France
+33-1-55-61-98-98
www.digi.fr

Digi International
Japan
+81-3-5428-0261
www.digi-intl.co.jp

Digi International
Singapore
+65-6213-5380

Digi International
China
+86-21-50492199
www.digi.com.cn



www.digi.com

Компания «Life Electronics» занимается поставками электронных компонентов импортного и отечественного производства от производителей и со складов крупных дистрибьюторов Европы, Америки и Азии.

С конца 2013 года компания активно расширяет линейку поставок компонентов по направлению коаксиальный кабель, кварцевые генераторы и конденсаторы (керамические, пленочные, электролитические), за счёт заключения дистрибьюторских договоров

Мы предлагаем:

- Конкурентоспособные цены и скидки постоянным клиентам.
- Специальные условия для постоянных клиентов.
- Подбор аналогов.
- Поставку компонентов в любых объемах, удовлетворяющих вашим потребностям.
- Приемлемые сроки поставки, возможна ускоренная поставка.
- Доставку товара в любую точку России и стран СНГ.
- Комплексную поставку.
- Работу по проектам и поставку образцов.
- Формирование склада под заказчика.
- Сертификаты соответствия на поставляемую продукцию (по желанию клиента).
- Тестирование поставляемой продукции.
- Поставку компонентов, требующих военную и космическую приемку.
- Входной контроль качества.
- Наличие сертификата ISO.

В составе нашей компании организован Конструкторский отдел, призванный помогать разработчикам, и инженерам.

Конструкторский отдел помогает осуществить:

- Регистрацию проекта у производителя компонентов.
- Техническую поддержку проекта.
- Защиту от снятия компонента с производства.
- Оценку стоимости проекта по компонентам.
- Изготовление тестовой платы монтаж и пусконаладочные работы.



Тел: +7 (812) 336 43 04 (многоканальный)

Email: org@lifeelectronics.ru