

SERIAL I/O REAL TIME CLOCK

■ GENERAL DESCRIPTION

The **NJU6350** is a serial I/O Real Time Clock suitable for 4 bits micro-processor.

It contains quartz crystal oscillator, counter, shift register, voltage regulator, voltage detector, and interface controller.

The **NJU6350** required only 3-port of microprocessor for data transfer, and the microprocessor can receive the data at any time when the microprocessor requires.

The operating voltage is as wide as 2.0V to 5.5V, consequently, the **NJU6350** can count accurate time data even if the back up period.

Furthermore, the long time back up is available as the current consumption during the back up period is less than 2 μ A.

■ PACKAGE OUTLINE



NJU6350R



NJU6350C

■ FEATURES

- Operating Voltage : 3.0V \pm 20%
2.0V to 5.5V (The clock operation)
- Low operating current : 0.8 μ A (Typ.) at 2.0V
2.0 μ A (Max.) at 2.0V
- BCD Counts of Seconds, Minutes, Hours, Days of Week, Date, Month and Year
- Required only 3-port (DATA, CLK and CE)
- Low Battery Detector (Low voltage alarm signal output)
- Automatic Leap Year Compensation : Up to AD 2099
- Package Outline : VSP 8 / Chip
- C-MOS Technology

■ PIN CONFIGURATION

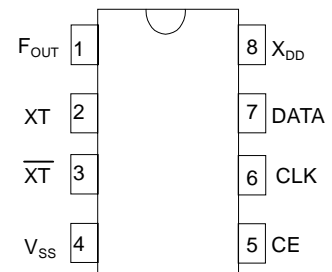

NJU6350

■ BLOCK DIAGRAM

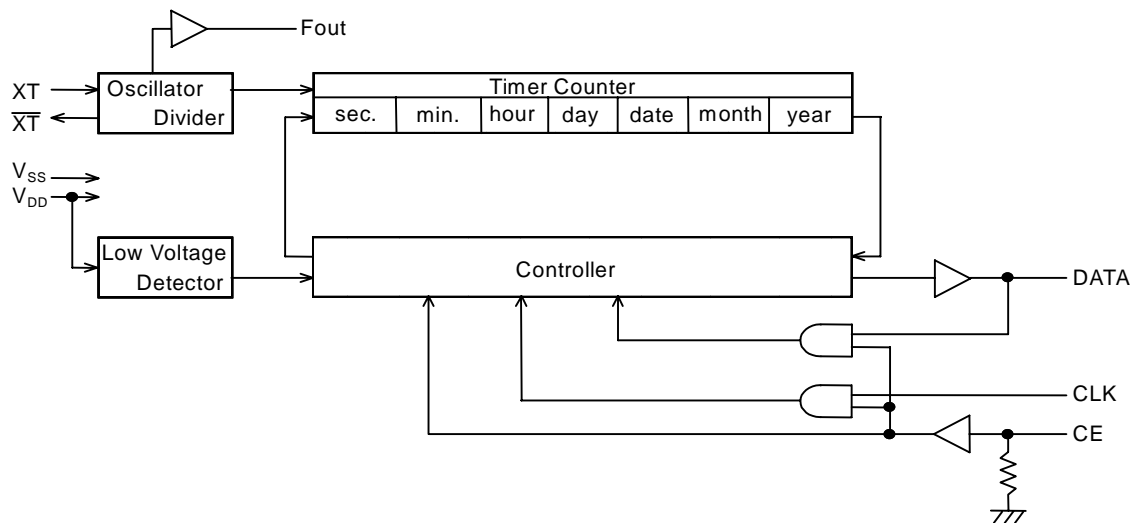

■ TERMINAL DESCRIPTION

No.	SYMBOL	I/O	FUNCTION
1	Fout	O	Oscillator output terminal. ON :It outputs oscillator signal , frequency 32.768kHz. OFF :It is in high impedance status.
2	XT	I	Quartz crystal connect terminal (f = 32.768kHz).
3	XT	O	
4	V _{SS}	Power	GND
5	CE	I	Chip enable terminal (With pull-down resistor). " H " : Data input/output available " L " : Data terminal is in high impedance status. When the data input/output is executed consequently, the CE terminal should be set to " L " level at the data transmission interval.
6	CLK	I	Clock terminal. The Data Input/Output is synchronized by this clock. When the CE terminal is "L", the data input is not available. When the CE signal which is raising edge or falling edge, the CLK signal should be fixed to " L ".
7	DATA	I/O	Serial timer data input/output terminal. This terminal is switched to input or output by system control data. (Default : input) When the CE terminal is set to " L ", the data terminal is high impedance.
8	V _{DD}	Power	Power supply The rising time of V _{DD} should be less than 10mS.

FUNCTIONAL DESCRIPTION

1. Timer and System control data format

The **NJU6350** adopts BCD code consisting of 4 bits per digit.

The calendar function including the last date of each month and the leap year calculation is executed automatically. The system control data operates Data I/O mode set, Oscillator output set and Test mode set.

The unused bit for the Timer and System control data is always set to " 0 ".

< System control data format >

System control data block				MSB					LSB		
C2	C1	C0	RW	C2	C1	C0	RW				
0	0	0	1	C o n t e n t s							
				Writing the data of oscillator output / test mode set							
				F = " 0 " : Oscillator output off (high impedance status)							
				F = " 1 " : Oscillator output on							
				T0 to 6: Test mode set (Normally all " 0 ")							
				MSB				LSB			
				F	T6	T5	T4	T3	T2	T1	T0
0	0	1	1	Writing the data of " Year "							
0	1	0	1	Writing the data of " Month "							
0	1	1	1	Writing the data of " Date "							
1	0	0	1	Writing the data of " Days of Week "							
1	0	1	1	Writing the data of " Hour "							
1	1	0	1	Writing the data of " Minute "							
1	1	1	1	Writing the data of " Second "							
0	0	1	0	Reading the data of " Year "							
0	1	0	0	Reading the data of " Month "							
0	1	1	0	Reading the data of " Date "							
1	0	0	0	Reading the data of " Days of Week "							
1	0	1	0	Reading the data of " our "							
1	1	0	0	Reading the data of " Minute "							
1	1	1	0	Reading the data of " Second "							
0	0	0	0	nvalidity							

< Timer data format >

	MSB							LSB	Range
Second	0	S6	S5	S4	S3	S2	S1	S0	0 — 59
Minute	0	m6	m5	m4	m3	m2	m1	m0	0 — 59
Hour	0	0	H5	H4	H3	H2	H1	H0	0 — 23
Days of Week				DC	W2	W1	W0	1 — 7	
Date	0	0	D5	D4	D3	D2	D1	D0	1 — 31
Month	0	0	0	M4	M3	M2	M1	M0	1 — 12
Year	Y7	Y6	Y5	Y4	Y3	Y2	Y1	Y0	0 — 99

Note1) The bit of " DC " in the " Days of Week " is a flag as the result of Low Voltage Detection. If the supply voltage is reduced to the detection voltage level, then the flag of " DC " is set to "1" at the read operation, and else the flag is always " 0 ".

(Note2) Only the data of Sec..., ...,Year as data of Timer and Calendar must be written to the **NJU6350** why any other data will be causes in malfunction of the timer counter.

NJU6350

2. Data writing operation

Data writing performs to set the system control data block (4 bits) and the mode set data (Oscillator output control and Test mode set) or the timer data block (8 bits, but only data of " Days of Week " is 4 bits) to **NJU6350**.

The CE terminal is set to " H ", and the data is written into the shift register in the **NJU6350** from the DATA terminal synchronizing with the rising edge of the clock signal input from the CLK terminal.

At first, System control data is written into **NJU6350**. The first 4 bits of them are effective. When the bit of " RW " in System control data is " 1 ", the mode goes to writing. In the writing mode, the update of the timer is stopped and the oscillator divider is cleared excepting for the Oscillation output set and Test mode set.

At second, Timer data is written into **NJU6350**. The last 8 bits of them are effective. (In case of Days of week, the last 4 bits are effective.)

The data order to write is LSB first.

The oscillator divider starts the operation when the CE signal is changed from " H " or " L ".

< Writing timer data >

In case of November

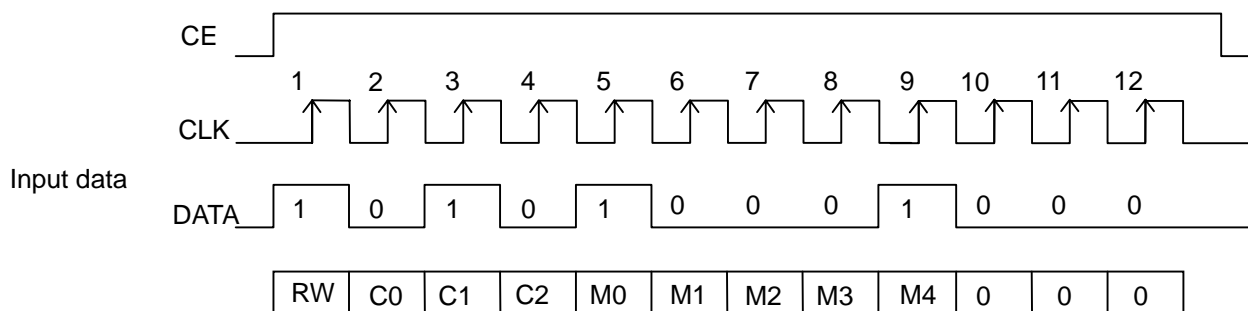

(Note3) In case of over than 12 bits data, valid data is the first 4 bits as System control data and the last 8 bits as Timer data. (In case of Days of week, it is the last 4 bits is effective.)

3. Data reading operation

Data reading performs to send the Timer data (8 bits, but only data of " Days of Week " is 4 bits) corresponding the system control data from **NJU6350** after the system control data (4 bits) is set to **NJU6350**.

The CE terminal is set to " H ", and the System control data are written into the shift register in the **NJU6350** from the DATA terminal synchronized with the rising edge of the clock signal input from the CLK terminal.

At first, System control data is written into **NJU6350**. The first 4 bits of them are effective. When the bit of " RW " in System control data (Except the " 0,0,0,0 " data.) is " 0 " the mode goes to reading. When the falling edge of the clock signal is input from the CLK terminal just after the recognition of reading mode, the DATA terminal is changed from Input to Output. The first 8 bits of Read data is effective. (In case of Days of week, the first 4 bits is effective.) After the falling edge of the CE terminal, the DATA terminal is changed from Output to Input. The data order to read is LSB first.

(Note4) In case of counting the timer up during the data reading.

The difference between the read out data of timer and the actual timer data is sometimes occurred. (The difference range depend on condition.)

In case of " 99.12.31.Sat.23:59:59 " at the current time, the update is operated immediately after year but " 99 " is read out, the data is the result of reading operation is " 99.1.1.Sun.0:0:0 " instead of the true data " 00.1.1.Sun.0:0:0 ".

< Reading timer data >

In case of November

The DATA terminal is changed over from Output to Input

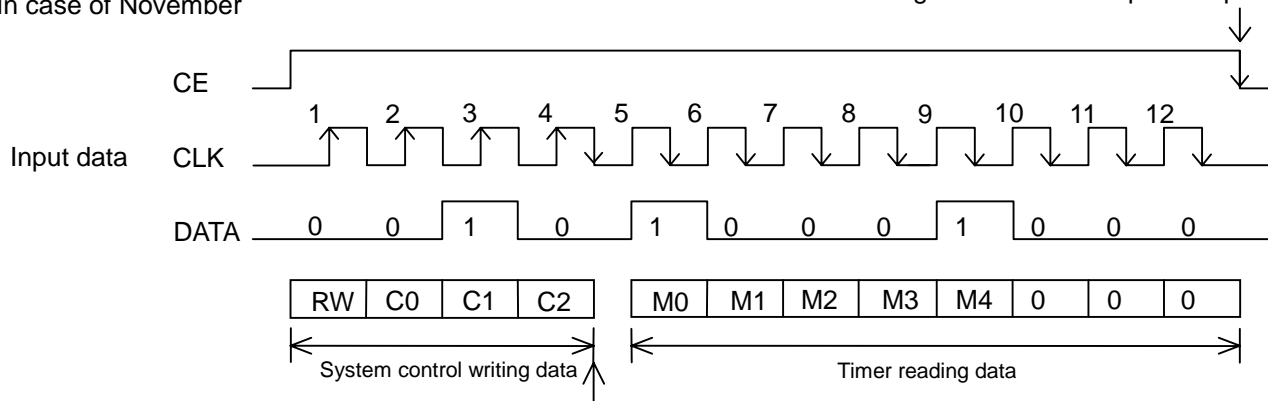

The DATA terminal is changed over from Input to Output at the arrow.

(Note5) The first 8 bits of timer data are effective. (In case of Days of week, the first 4 bits are effective.)

4. Voltage Detect Function

The **NJU6350** incorporates the low battery detector. If the supply voltage reduce to the detection level, Detector check flag is " 1 " as warning code for the CPU. When power on reset or data writing operation, the Detector check flag is set " 0 ". The low battery detector operates one time per 1 second.

5. Data Access

The **NJU6350** can operate from 2.0V to 5.5V. However, the data access must operate in the range of $3V \pm 20\%$.

6. Crystal Oscillator Circuit

The crystal oscillator circuit in the **NJU6350** incorporates the capacitors. Therefore, it can operate with only external crystal for 32.768kHz.

However, the external capacitors are required to get the matching between the incorporated oscillator and a external crystal in accordance with the characteristics of crystal.

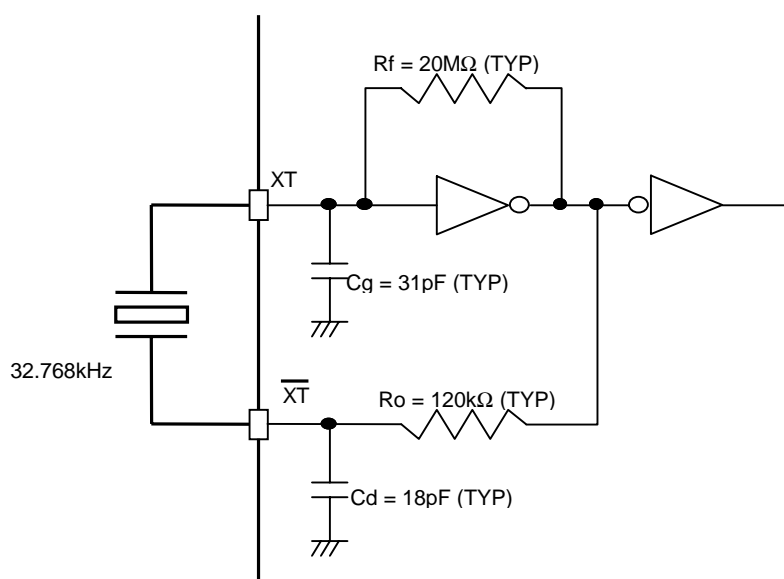

■ ABSOLUTE MAXIMUM RATINGS

PARAMETER		SYMBOL	RATING	UNIT
Supply Voltage		V_{DD}	-0.3 to +6.0	V
Input Voltage		V_I	$V_{SS}-0.3$ to $V_{DD}+0.3$	V
Operating Temperature		T_{opr}	-30 to +80	°C
Storage Temperature		T_{stg}	-40 to +125	°C
Power Dissipation	VSP	P_D	320	mW

Note1) Decoupling capacitor should be connected between V_{DD} and V_{SS} due to the stabilized operation of the circuit.

■ ELECTRICAL CHARACTERISTICS

DC Characteristics (Unless Otherwise Specified $V_{DD}=3V\pm 20\%$, $V_{SS}=0V$, $T_a=25^\circ C$)

PARAMETER	SYMBOL	CONDITIOINS	MIN.	TYP.	MAX.	UNIT
Operating Voltage	V_{DD}		2.0		3.6	V
Detecting Voltage	V_{DET}		1.3	1.6	1.9	V
Operating Current	I_{DD1}	Oscillation Output off, XT=32.768kHz $V_{DD}=2.0V$, CE=CLK=0V		0.8	2.0	μA
	I_{DD2}	Oscillation Output off, XT=32.768kHz $V_{DD}=3.6V$, CE=CLK=0V		0.8	2.0	
3-state Leakage Current	I_{TSL}	DATA Terminal (CE=0V)	-2.0		2.0	μA
Input Leakage Current	I_{IL}	CLK Terminal	-1.0		1.0	μA
Input Current	I_{IN}	CE Terminal ($V_{DD}=CE=3.6V$)			12.0	μA
Input Voltage	V_{IH}	CLK, CE, DATA Terminals	$V_{DD} \times 0.8$		V_{DD}	μA
	V_{IL}	CLK, CE, DATA Terminals	V_{SS}		$V_{DD} \times 0.2$	V
Output Current	I_{OH1}	DATA Terminal ($V_{DD}=2.4V$, $V_{OH}=1.8V$)	0.4			mA
	I_{OH2}	F_{OUT} Terminal ($V_{DD}=2.4V$, $V_{OH}=1.8V$)	1.0			
	I_{OL}	DATA, F_{OUT} Terminals ($V_{DD}=2.4V$, $V_{OL}=0.4V$)	1.0			

AC Characteristics (Unless Otherwise Specified $V_{DD}=3V\pm 20\%$, $V_{SS}=0V$, $T_a=25^\circ C$)

PARAMETER	SYMBOL	CONDITIONS	MIN.	TYP.	MAX.	UNIT
CLK Pulse " H " Period	t_{CWH}		0.47		5000	μS
CLK Pulse " L " Period	t_{CWL}		0.47		5000	μS
CE Set-up Time Before CLK Rising	t_{CS}		470			nS
CE Hold Time After CLK Falling	t_{CH}		20			nS
DATA Set-up Time Before CLK Rising	t_{WDS}		100			nS
DATA Hold Time After CLK Rising	t_{WDH}		20			nS
DATA Delay Time CLK Falling	t_{RDD}	$V_{DD}=2.4V$ CL=50pF			200	nS
Rise / Fall Time	t_{RF}				40	nS

■ TIMING CHART of Real Time Clock Block

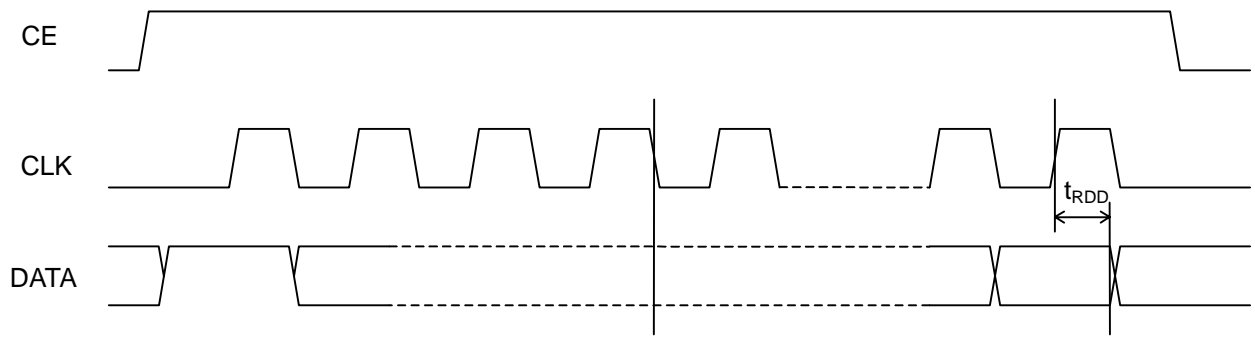
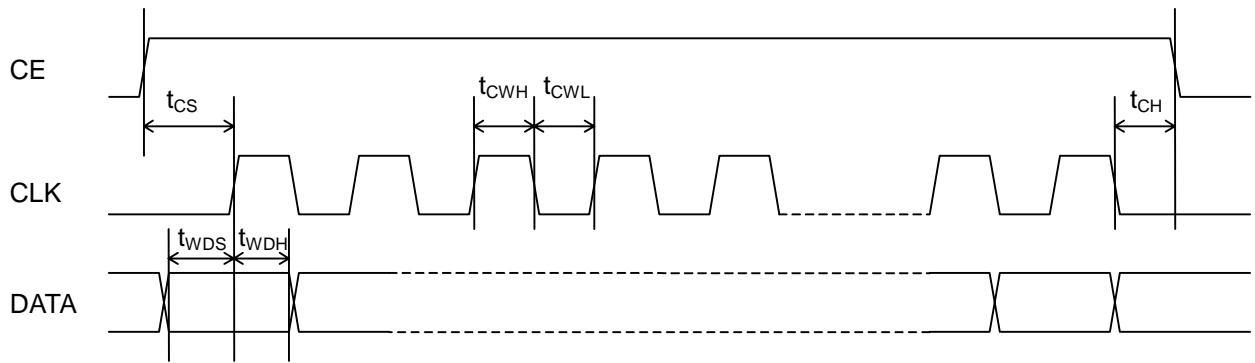
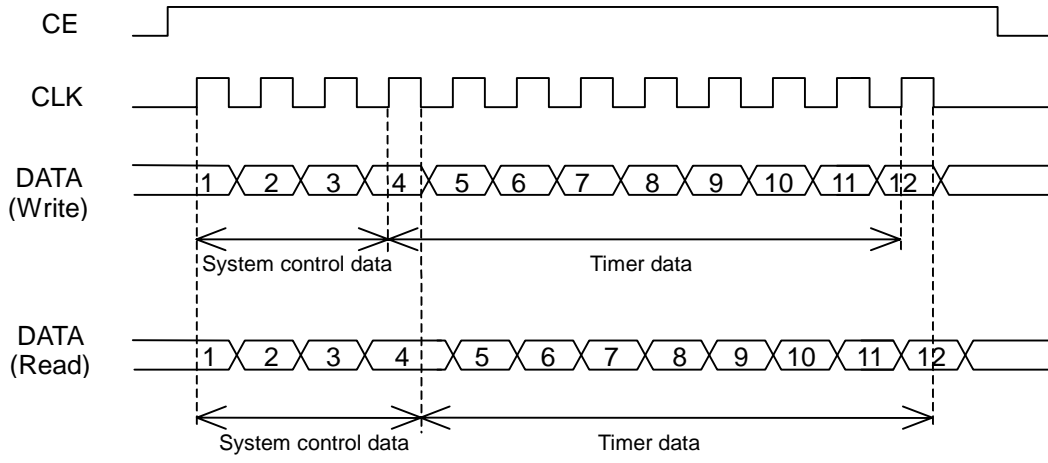

The DATA terminal is changed over from Input and

NJU6350

APPLICATION CIRCUIT

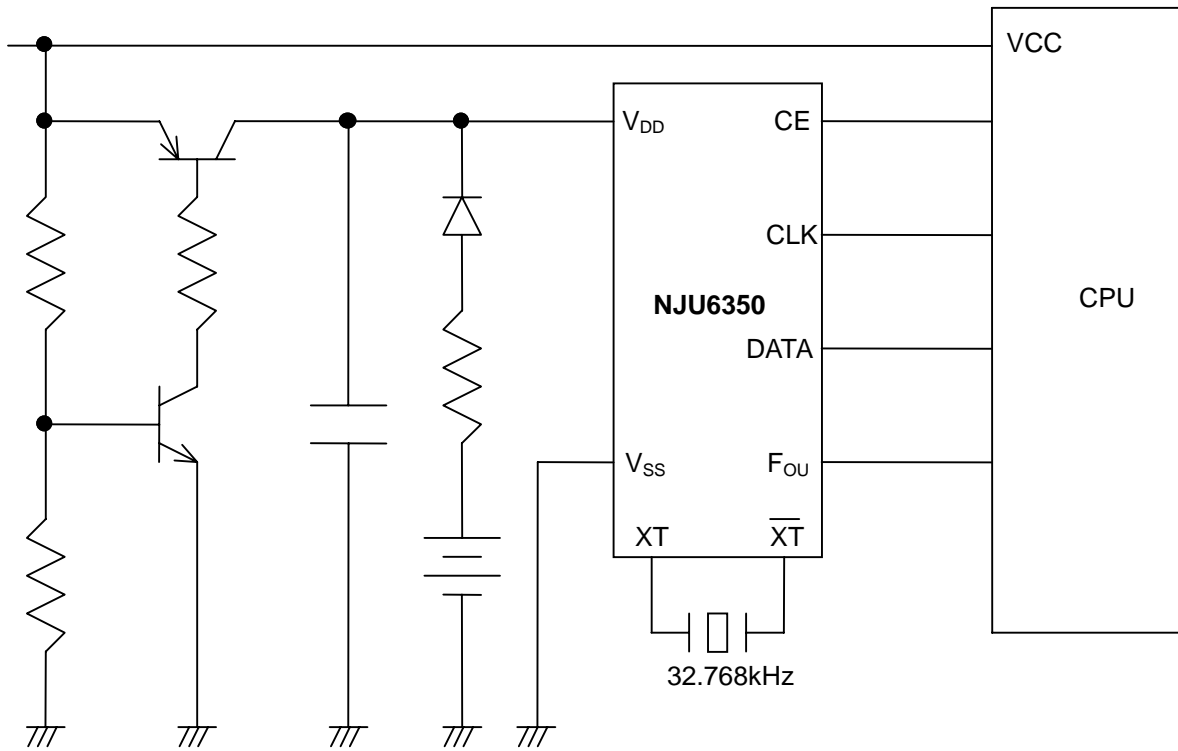

MEMO

[CAUTION]

The specifications on this databook are only given for information, without any guarantee as regards either mistakes or omissions. The application circuits in this databook are described only to show representative usages of the product and not intended for the guarantee or permission of any right including the industrial rights.

Mouser Electronics

Authorized Distributor

Click to View Pricing, Inventory, Delivery & Lifecycle Information:

[NJR:](#)

[NJU6350R-TE1](#)

Компания «Life Electronics» занимается поставками электронных компонентов импортного и отечественного производства от производителей и со складов крупных дистрибьюторов Европы, Америки и Азии.

С конца 2013 года компания активно расширяет линейку поставок компонентов по направлению коаксиальный кабель, кварцевые генераторы и конденсаторы (керамические, пленочные, электролитические), за счёт заключения дистрибьюторских договоров

Мы предлагаем:

- Конкурентоспособные цены и скидки постоянным клиентам.
- Специальные условия для постоянных клиентов.
- Подбор аналогов.
- Поставку компонентов в любых объемах, удовлетворяющих вашим потребностям.
- Приемлемые сроки поставки, возможна ускоренная поставка.
- Доставку товара в любую точку России и стран СНГ.
- Комплексную поставку.
- Работу по проектам и поставку образцов.
- Формирование склада под заказчика.
- Сертификаты соответствия на поставляемую продукцию (по желанию клиента).
- Тестирование поставляемой продукции.
- Поставку компонентов, требующих военную и космическую приемку.
- Входной контроль качества.
- Наличие сертификата ISO.

В составе нашей компании организован Конструкторский отдел, призванный помогать разработчикам, и инженерам.

Конструкторский отдел помогает осуществить:

- Регистрацию проекта у производителя компонентов.
- Техническую поддержку проекта.
- Защиту от снятия компонента с производства.
- Оценку стоимости проекта по компонентам.
- Изготовление тестовой платы монтаж и пусконаладочные работы.



Тел: +7 (812) 336 43 04 (многоканальный)

Email: org@lifeelectronics.ru