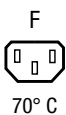

IEC Appliance Inlet C14 with Appliance Outlet F, Line Switch 2-pole and Voltage Selector

**Description**

- Panel Mount:
Snap-in version from rear-side
- 4 Functions:
Appliance Inlet Protection class I, Connector Protection class I, Line Switch 1- or 2-pole, with or without voltage selector (Jumper)

Approvals

- VDE Certificate Number: 6090
- UL File Number: E96454
- CSA File Number: 38456

Characteristics

- Short Mounting Depth
- All single elements are already wired except voltage selector
- Line switch non-illuminated
- Voltage selector for two voltage ranges
- Insulation cover on the rear-side
- Especially suitable for use in switching power supplies
- Qualified for use in equipment according IEC/EN 60950

Other versions on request

- Panel thickness 1.0 mm and 1.2 mm
- Unwired (without pc-board), with pin-terminals
- Wired (with pc-board), with flexible wires
- Line switch with other rocker marking
- Without cover
- Voltage selector with other marking

References

This type is Phase-out without alternate type
Last order date: 30.04.2011

Weblinks

[pdf](#), [html](#), [General Product Information](#), [Approvals](#), [RoHS](#), [CHINA-RoHS](#), [Mating Connectors](#), [e-Store](#), [SCHURTER-Stock-Check](#), [Distributor-Stock-Check](#), [Accessories](#)

Technical Data

Ratings IEC	10A / 250VAC; 50Hz	Appliance Inlet / Appliance Outlet	C14 acc. to IEC/EN 60320-1 and F acc. to IEC/EN 60320-2-2, UL 498, CSA C22.2 no. 42 (for cold conditions) pin-temperature 70 °C, 10A, Protection Class 1
Ratings UL/CSA	10A / 250VAC; 60Hz	Line Switch	Rocker switch 1 or 2 pole, non-illuminated, acc. to IEC 61058-1 Technical details
Dielectric Strength	> 2.5kVAC between L-N > 3kVAC between L/N-PE (1 min/50Hz)	Voltage Selectors	optional jumper, 2 pos.
Allowable Operation Temp.	-25 °C to 70 °C		
Degree of Protection	from front side IP 40 acc. to IEC 60529		
Protection Class	Suitable for appliances with protection class 1 acc. to IEC 61140		
Terminal	Quick connect terminals 4.8 x 0.8 mm Solder terminal on request Solder terminals on voltage selector		
Panel Thickness s	Snap-in: 0.8/1.5 mm (other on request)		
Material: Housing	Thermoplastic, black, UL 94V-2		

Dimensions

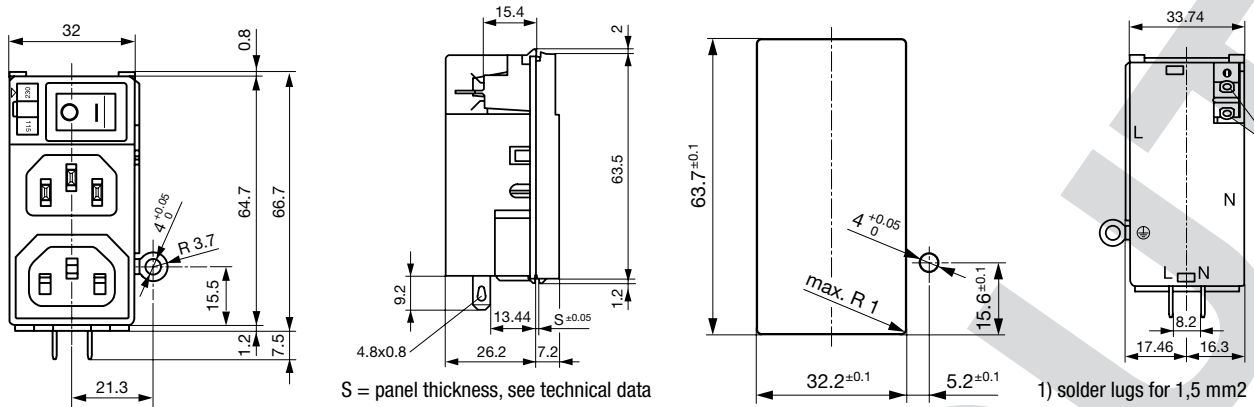

Diagrams

Version: line switch 2-pole

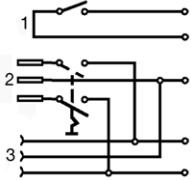

- 1) voltage selector
- 2) appliance-inlet
- 3) appliance-outlet

Voltage selector

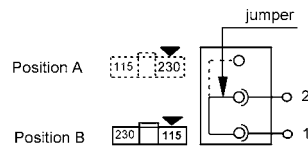

Variants

- Basic version:
- Marking of the voltage selector 115/230
 - with cover on the rear-side

Panel Thickness s [mm]	Line Switch	Voltage Selectors	Order Number
0.8	1-pole		4307.3001
1.5	1-pole		4307.3004
0.8	1-pole	●	4307.3211
1.5	1-pole	●	4307.3214
0.8	2-pole		4307.4001
1.5	2-pole		4307.4004
0.8	2-pole	●	4307.4211
1.5	2-pole	●	4307.4214

Packaging unit 250 Pcs

Mating Inlets/Plugs

Category / Description

[Interconnection Cord Overview complete](#)



Interconnection Cord with IEC Plug E, Angled	0607
Interconnection Cord with IEC Plug E, Angled	0608
Interconnection Cord with IEC Plug E, Straight	0609
Interconnection Cord with IEC Plug G, Angled	607B
Interconnection Cord with IEC Plug G, Angled	608B
Interconnection Cord further types to PMM	...



PlugOverview complete

IEC Plug E, Cord Connector (Rewireable), Straight, max. cable Diameter 8.5 mm	4732
IEC Plug E, Cord Connector (Rewireable), Angled, max. Cable Diameter 10 mm	4733
IEC Plug E, Cord Connector (Rewireable), Straight, max. Cable Diameter 10 mm	4735
IEC Plug E, Cord Connector (Rewireable), Angled, max. Cable Diameter 10 mm	4736
IEC Plug E, Cord Connector (Rewireable), Straight	9009

Plugfurther types toPMM

...

Mating Outlets/Connectors



Appliance OutletOverview complete

IEC Appliance Outlet F, Screw-on Mounting, Front Side, Solder Terminal	4787
IEC Appliance Outlet F, Snap-in Mounting, Front Side, Solder or Quick-connect Terminal	4788
IEC Appliance Outlet F or H, Screw-on Mounting, Front Side, Solder, PCB or Quick-connect Terminal	5091
IEC Appliance Outlet F or H, Screw-on Mounting, Front Side, Solder or Quick-connect Terminal	5092

Appliance Outletfurther types toPMM



ConnectorOverview complete

IEC Connector C15, Rewireable, Straight	0101
IEC Connector C15A, Rewireable, Straight	0102
IEC Connector C15A, Rewireable, Straight	0102-G
IEC Connector C15A, Rewireable, Angled	0112
IEC Connector C13, Rewireable, Angled	4012

Connectorfurther types toPMM

...



Power CordOverview complete

Power Cord with IEC Connector C13, Angled	0311
Power Cord with IEC Connector C13, Angled	3011
Power Cord with IEC Connector C13, Angled	3012
Power Cord with IEC Connector C13, Angled	3013
Power Cord with IEC Connector C13	3020

Power Cordfurther types toPMM

...

Компания «Life Electronics» занимается поставками электронных компонентов импортного и отечественного производства от производителей и со складов крупных дистрибьюторов Европы, Америки и Азии.

С конца 2013 года компания активно расширяет линейку поставок компонентов по направлению коаксиальный кабель, кварцевые генераторы и конденсаторы (керамические, пленочные, электролитические), за счёт заключения дистрибьюторских договоров

Мы предлагаем:

- Конкурентоспособные цены и скидки постоянным клиентам.
- Специальные условия для постоянных клиентов.
- Подбор аналогов.
- Поставку компонентов в любых объемах, удовлетворяющих вашим потребностям.
- Приемлемые сроки поставки, возможна ускоренная поставка.
- Доставку товара в любую точку России и стран СНГ.
- Комплексную поставку.
- Работу по проектам и поставку образцов.
- Формирование склада под заказчика.
- Сертификаты соответствия на поставляемую продукцию (по желанию клиента).
- Тестирование поставляемой продукции.
- Поставку компонентов, требующих военную и космическую приемку.
- Входной контроль качества.
- Наличие сертификата ISO.

В составе нашей компании организован Конструкторский отдел, призванный помогать разработчикам, и инженерам.

Конструкторский отдел помогает осуществить:

- Регистрацию проекта у производителя компонентов.
- Техническую поддержку проекта.
- Защиту от снятия компонента с производства.
- Оценку стоимости проекта по компонентам.
- Изготовление тестовой платы монтаж и пусконаладочные работы.



Тел: +7 (812) 336 43 04 (многоканальный)
Email: org@lifeelectronics.ru