

LT3952EFE 60V LED Driver with Internal 4A Switch

DESCRIPTION

Demonstration Circuit DC2013A is a 60V LED driver with internal 4A switch featuring the [LT[®]3952](#) monolithic LED driver. It accepts an input voltage from 5V to 36V (with transient to 42V) and boosts to a single string of LEDs up to 50V LEDs at 330mA. DC2013A features an integrated 4A switch, constant-current and constant-voltage output control as well as input current limit and monitoring.

The LT3952 has a wide input voltage range down to 3V and up to 42V. It has adjustable switching frequency between 200kHz and 3MHz. It has an option for external frequency synchronization or spread spectrum frequency modulation. It has high PWM dimming capability from an external signal and can be PWM dimmed with an internally generated PWM oscillator and analog input signal. It can be analog dimmed with a control voltage on its control pin. LT3952 features both Open-LED and Short-LED (LED+ to GND) protection as well as fault output flags for each. Although DC2013A is assembled as a boost LED driver, it can be altered to be run as a buck mode, buck-boost mode or boost-buck LED driver.

There is another demonstration circuit featuring LT3952 at 2.0MHz (DC2361A).

DC2013A features an option to turn on spread spectrum by simply changing the position of a jumper from NO SPREAD to SPREAD or to EXTERNAL SYNC.

Small ceramic input and output capacitors are used to save space and cost. The Open-LED overvoltage protection uses the IC's constant-voltage regulation loop to regulate the output to approximately 55V if the LED string is opened

although it may reach 59V peak during transient from running LEDs to open. There is a protection diode from LED+ to GND to prevent negative ringing during a short-circuit with long wires.

There is undervoltage and overvoltage lockout that can be adjusted on the circuit with a few simple resistor choices.

There is an EMI filter on the input of DC2013A. This EMI filter has both an LC stage to reduce EMI below 20MHz and a ferrite bead to reduce higher frequency EMI. The PCB layout contains a small hot-loop for minimized high frequency EMI. The EMI filter can be used by connecting to the "EMI V_{IN}" terminal. However, if the EMI filter is not needed, the input connection can be directly to the PV_{IN} terminal. If the EMI filter is not used, it is recommended to remove the EMI filter if EMI measurements are being made from the PV_{IN} terminal for base EMI testing. It can be replaced for EMI testing at the EMI V_{IN} terminal.

The LT3952 data sheet gives a complete description of the part, operation and applications information. The data sheet must be read in conjunction with this Demo Manual for Demonstration Circuit 2013A. The LT3952EFE is assembled in a 28-lead plastic TSSOP (FE) package with a thermally enhanced ground pad. Proper board layout is essential for maximum thermal performance. See the data sheet section "Layout Considerations".

Design files for this circuit board are available at <http://www.linear.com/demo/DC2013A>

LT, LT, LTC, LTM, Linear Technology and the Linear logo are registered trademarks of Analog Devices, Inc. All other trademarks are the property of their respective owners.

PERFORMANCE SUMMARY

| PARAMETER | CONDITION | MIN | TYP | MAX | UNITS |
|--|--|-----------|------------|-----|----------|
| Input Voltage PV_{IN} and EMI V_{IN} Range | Operating $V_{IN} = PV_{IN}$ $V_{LED} > 36V$ | 5 | | 36 | V |
| Switching Frequency | $R1 = 287k$ | | 350 | | kHz |
| I_{LED} | $R1 = 0.75\Omega$ $7.0V < PV_{IN} < 36V$ $V_{LED} > 36V$ | | 333 | | mA |
| Low PV_{IN} I_{LED} (CTRL Foldback) | $R1 = 0.75\Omega$ $PV_{IN} = 5.0V$ $R1 = 0.75\Omega$ $PV_{IN} = 6.0V$ | | 270 320 | | mA mA |
| V_{LED} Range | $R4 = 1M$, $R5 = 22.6k$ | PV_{IN} | | 50 | V |
| Open-LED Voltage V_{OUT} | $R4 = 1M$, $R5 = 22.6k$ | | 54.3 | | V |
| Typical Efficiency (100% PWM DC) | $PV_{IN} = 14V$ $V_{LED} = 50V$ $I_{LED} = 333mA$ | | 92.2 | | % |
| Input Undervoltage Lockout (Falling Turn-Off) | $R7 = 499k$, $R8 = 196k$, $R9 = 24.3k$ | | 4.1 | | V |
| Input Undervoltage Lockout (Rising Turn-On) | $R7 = 499k$, $R8 = 196k$, $R9 = 24.3k$ | | 5.4 | | V |
| V_{ISMON} | Operating $I_{LED} = 330mA$ | | 1.0 | | V |
| Peak Switch Current Limit | Operating | | 4 | | A |

QUICK START PROCEDURE

Demonstration Circuit 2013A is easy to set up to evaluate the performance of the LT3952. Follow the procedure below:

1. Connect a string of LEDs that will run with forward voltage less than or equal to 50V (at 330mA), but greater than PV_{IN} , to the LED+ and GND terminals on the PCB as shown in Figure 1.
2. Connect the EN/UVLO terminal to GND.
3. With power off, connect the input power supply to the EMI V_{IN} (or PV_{IN}) and GND terminals. Make sure that the DC input voltage will not exceed 42V (or V_{LED}).
4. Turn the input power supply on and make sure the voltage is between 5V and 36V (or V_{LED}) for proper operation.
5. Release the EN/UVLO-to-GND connection.
6. Observe the LED strings running at the programmed LED current.
7. To change the brightness with analog dimming, simply attach a voltage source to the CTRL terminal and set the voltage between 0V and 1.5V. See data sheet for details.
8. To change brightness with external PWM dimming, attach a 3V rectangular waveform with varying duty cycle to the PWM terminal.
9. To enable spread spectrum frequency modulation, simply change the position of the shunt on the SYNC/SPRD jumper to the SPREAD SPECTRUM position.

DEMO CIRCUIT OPTIONS

Demonstration Circuit 2013A can be adjusted for higher or lower output voltage, different LED current, or different topology. The following options are for simple changes to the demonstration circuit. The data sheet gives more information regarding designing with the LT3952. For more information, see the data sheet for details or contact Linear Tech customer support. For buck mode, V_{IN} and PV_{IN} must be separated by a trace cut on layer one. However, there is also a connection between PV_{IN} and V_{IN} on layer 3. Please see the layer files and make a drill hole to separate PV_{IN} and V_{IN} entirely for buck mode.

MAXIMUM LED VOLTAGE

DC2013A is set for 54.3V of overvoltage protection and the maximum LED string voltage used on the standard build should be 50V. Some margin is provided to limit the Open-LED overshoot above 55V in order to stay safely below the 60V limit. See data sheet for details.

CURRENT OR VOLTAGE REGULATION

The LT3952 can be used for constant-current or voltage regulation. If the load placed on the LED+ to GND terminals allows V_{OUT} to climb high enough for $V_{(ISP-ISN)} = 1.2V$, then the voltage regulation loop of the converter takes over. In this case, the compensation for a given channel should

QUICK START PROCEDURE

be adjusted for proper use as a constant-voltage regulator. The IC can be used as a boost or SEPIC constant-voltage regulator. Output voltage should remain below 60V when used as a constant-voltage device.

LED CURRENT

LED current on DC2013A is set for 330mA with 0.75Ω resistor R1. For a different maximum LED current, change this resistor. $250\text{mV}/R_{\text{LED}} = I_{\text{LED}}$.

A change in LED current or input voltage may lead to higher or lower maximum switch current. The maximum switch current for this converter is 4A and is fixed internally.

OVERVOLTAGE PROTECTION

Overvoltage protection is set with the resistor pair R4 and R5 for the boost topology. For buck mode, buck-boost mode, and boost-buck see data sheet for details how to set the feedback resistors. Note that R19, R20, R21, and Q1 are provided as optional placeholders on the demonstration circuit for simple feedback resistor changes for these topologies.

UNDERVOLTAGE AND OVERVOLTAGE LOCKOUT

UVLO and OVLO can be adjusted by changing the values of R7, R8 and R9.

Resistors R13, R14, and R15 are available for setting UVLO and OVLO separately or for referring them to OUT for other topologies.

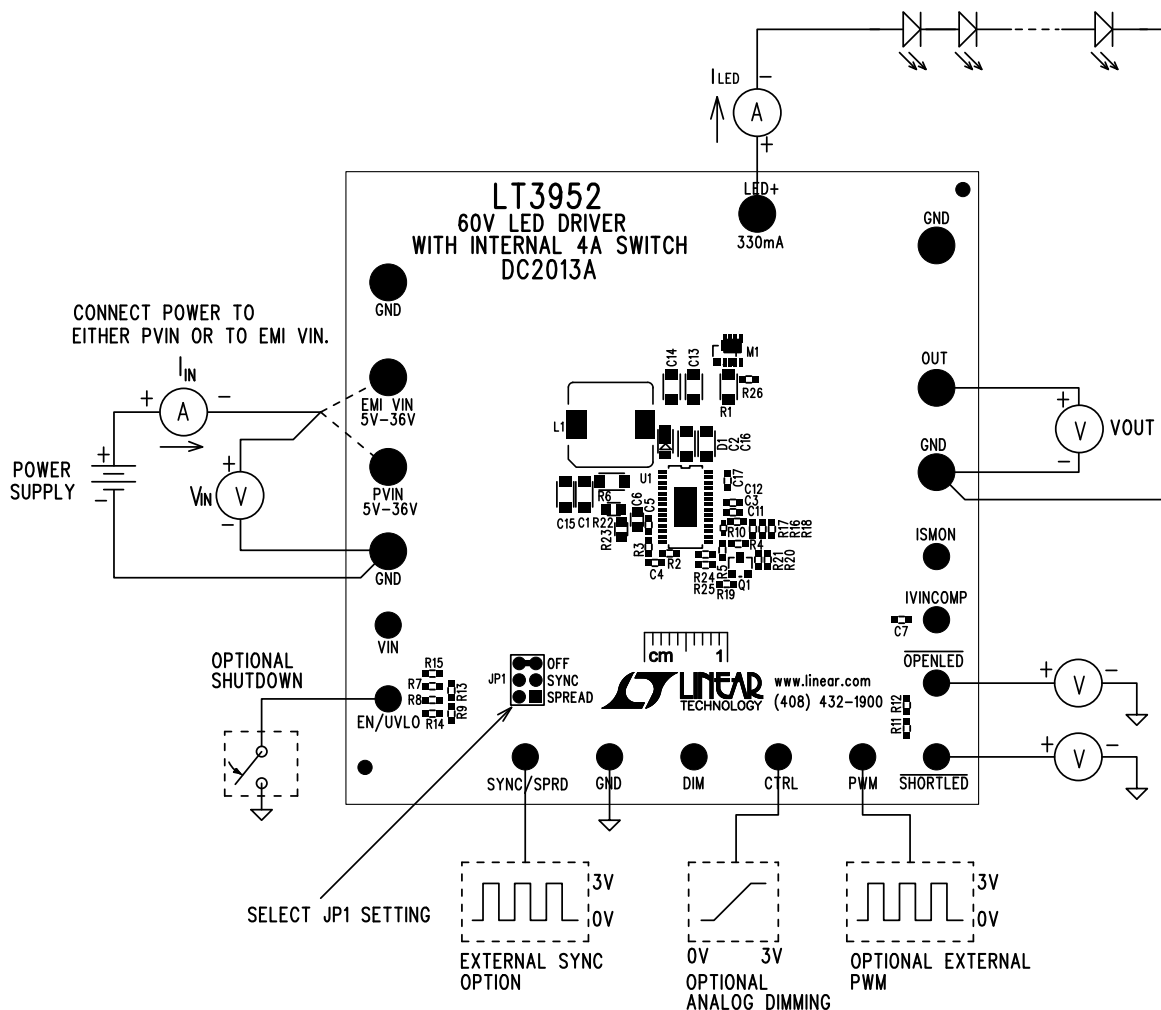

Figure 1. Test Procedure Setup Drawing for DC2013A

QUICK START PROCEDURE

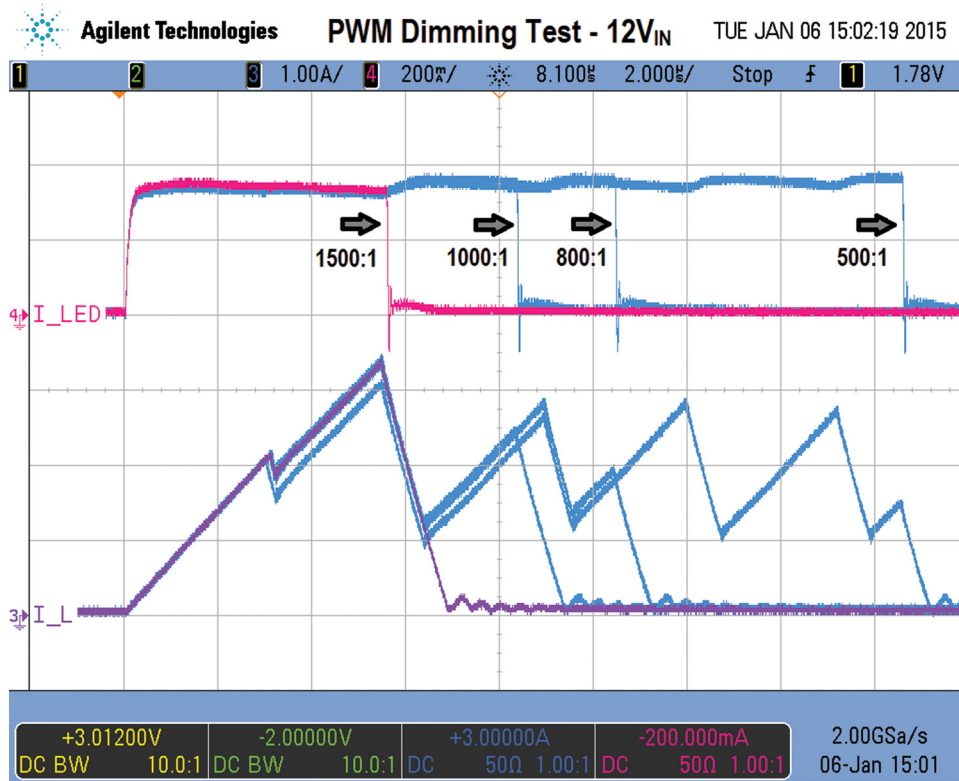

Figure 2. DC2013A 12V_{IN} 120Hz PWM Dimming Waveforms at Different PWM Duty Cycles with 1500:1 in Bold. I_{LED} Waveform (200mA/DIV) Is on Top (with 50V LED String) and I_{L1} Waveform (1A/DIV) Is on the Bottom

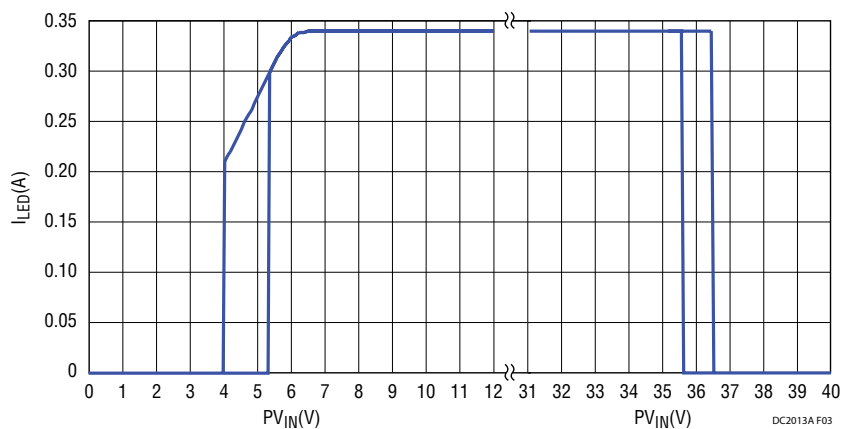
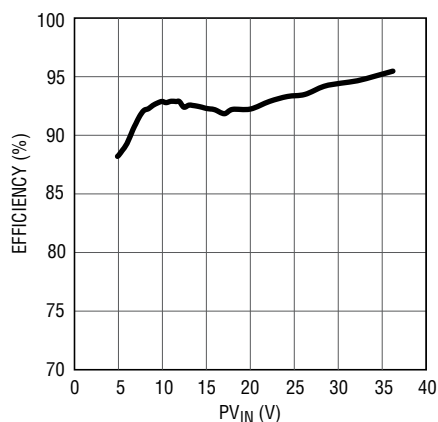

Figure 3. DC2013A CTRL LED Current Foldback at Low Input with UVLO and OVLO Falling and Rising

QUICK START PROCEDURE



DC2013A F04

Figure 4. DC2013A Efficiency at Maximum I_{LED} vs PV_{IN} with 50V LEDs (at 330mA)

PARTS LIST

| ITEM | QTY | REFERENCE | PART DESCRIPTION | MANUFACTURER/PART # |
|---------------------------------------|-----|-----------|---|------------------------------|
| Required Electrical Components | | | | |
| 1 | 1 | C1 | CAP., X5R, 10 μ F, 50V, 10% 1206 | MURATA, GRM31CR61H106KA12L |
| 2 | 1 | C2 | CAP., X7S, 4.7 μ F, 100V, 10% 1206 | AVX, 12061Z475KAT2A |
| 3 | 1 | C3 | CAP., X7R, 0.22 μ F, 10V, 10% 0603 | MURATA, GRM188R71A224KA01J |
| 4 | 1 | C4 | CAP., X7R, 4.7nF, 10V, 10% 0603 | AVX, 0603ZC472KAT2A |
| 5 | 1 | C5 | CAP., X5R, 2.2 μ F, 6.3V, 10% 0603 | AVX, 06036D225KAT2A |
| 6 | 1 | C6 | CAP., X7R, 1 μ F, 50V, 10% 0805 | MURATA, GRM21BR71H105KA12L |
| 7 | 1 | D1 | SCHOTTKY RECTIFIER | DIODES INC., DFSL260-7 |
| 8 | 1 | L1 | INDUCTOR, 15 μ H | WÜRTH ELEKTRONIK, 7447798151 |
| 9 | 1 | M1 | P-MOSFET, SI2307CDS, SOT23 | VISHAY, SI2307CDS-T1-GE3 |
| 10 | 1 | R1 | RES., CHIP, 0.75 Ω , 0.5W, 1% 1206 | SUSUMU, RL1632R-R750-F |
| 11 | 1 | R2 | RES., CHIP, 287k, 1/10W, 1% 0603 | VISHAY, CRCW0603287KFKEA |
| 12 | 1 | R3 | RES., CHIP, 3.0k, 1/10W, 5% 0603 | VISHAY, CRCW06033K00JNEA |
| 13 | 1 | R4 | RES., CHIP, 1M, 1/10W, 1% 0603 | VISHAY, CRCW06031M00FKEA |
| 14 | 1 | R5 | RES., CHIP, 22.6k, 1/10W, 1% 0603 | VISHAY, CRCW060322K6FKEA |
| 15 | 1 | R6 | RES., CHIP, 0.015 Ω , 1W, 1% 1206 | PANASONIC, ERJ-8BWF0R15V |
| 16 | 1 | U1 | I.C., LED Driver, TSSOP-28 | LINEAR TECH., LT3952EFE#PBF |

DEMO MANUAL DC2013A

PARTS LIST

| ITEM | QTY | REFERENCE | PART DESCRIPTION | MANUFACTURER/PART # |
|---------------------------------------|-----|---------------------------------|--|-----------------------------------|
| Optional Electrical Components | | | | |
| 1 | 1 | C7 | CAP., X7R, 0.47 μ F, 25V, 10% 0603 | MURATA, GRM188R71E474KA12D |
| 2 | 1 | C8 | CAP., ALUM., 33 μ F, 50V, 6.3 \times 7.7 | PANASONIC, EEHZA1H330XP |
| 3 | 1 | C9 | CAP., X5R, 2.2 μ F, 50V, 10% 1206 | MURATA, GRM31CR71H225KA88L |
| 4 | 1 | C10 | CAP., X5R, 0.1 μ F, 50V, 10% 0402 | MURATA, GRM155R61H104KE14J |
| 5 | 0 | C11, C12, C17 (OPT) | CAP., 0603 | |
| 6 | 0 | C13, C14 (OPT) | CAP., 1206 | |
| 7 | 0 | C15, C16 (OPT) | CAP., 1206 | |
| 8 | 0 | C18 (OPT) | CAP., 0805 | MURATA, GRM21BR71H105KA12L |
| 9 | 1 | D2 | RECTIFIER, SMA | DIODES INC., ES1B-13-F |
| 10 | 1 | FB1 | BEAD, CHIP, 100 Ω , 0805 | TDK, MPZ2012S101AT000 |
| 11 | 1 | L2 | INDUCTOR, 4.7 μ H | VISHAY, IHLP2020CZER4R7M11 |
| 12 | 0 | Q1 (OPT) | PNP SOT23 | |
| 13 | 1 | R7 | RES., CHIP, 499k, 1/10W, 1% 0603 | VISHAY, CRCW0603499KFKEA |
| 14 | 1 | R8 | RES., CHIP, 196k, 1/10W, 1% 0603 | VISHAY, CRCW0603196KFKEA |
| 15 | 1 | R9 | RES., CHIP, 24.3k, 1/10W, 1% 0603 | VISHAY, CRCW060324K3FKEA |
| 16 | 0 | R10 (OPT) | RES., 0402 | |
| 17 | 2 | R11, R12 | RES., CHIP, 100k, 1/10W, 1% 0603 | VISHAY, CRCW0603100KFKEA |
| 18 | 0 | R13-R15, R18-R21, R24-R26 (OPT) | RES., 0603 | |
| 19 | 1 | R16 | RES., CHIP, 1M, 1/10W, 1% 0603 | VISHAY, CRCW06031M00FKEA |
| 20 | 1 | R17 | RES., CHIP, 249k, 1/10W, 1% 0603 | VISHAY, CRCW0603249KFKEA |
| 21 | 0 | R22, R23 (OPT) | RES., 0805 | |
| Hardware | | | | |
| 1 | 8 | E1-E8 | TESTPOINT, TURRET, 0.094" PBF | MILL-MAX, 2501-2-00-80-00-00-07-0 |
| 2 | 11 | E9-E19 | TESTPOINT, TURRET, 0.061" PBF | MILL-MAX, 2308-2-00-80-00-00-07-0 |
| 3 | 1 | JP1 | HEADER 3-PIN 0.079" DOUBLE ROW | WÜRTH ELEKTRONIK, 620 006 211 21 |
| 4 | 1 | XJP1 | SHUNT, 0.079" CENTER | WÜRTH ELEKTRONIK, 608 002 134 21 |

SCHEMATIC DIAGRAM

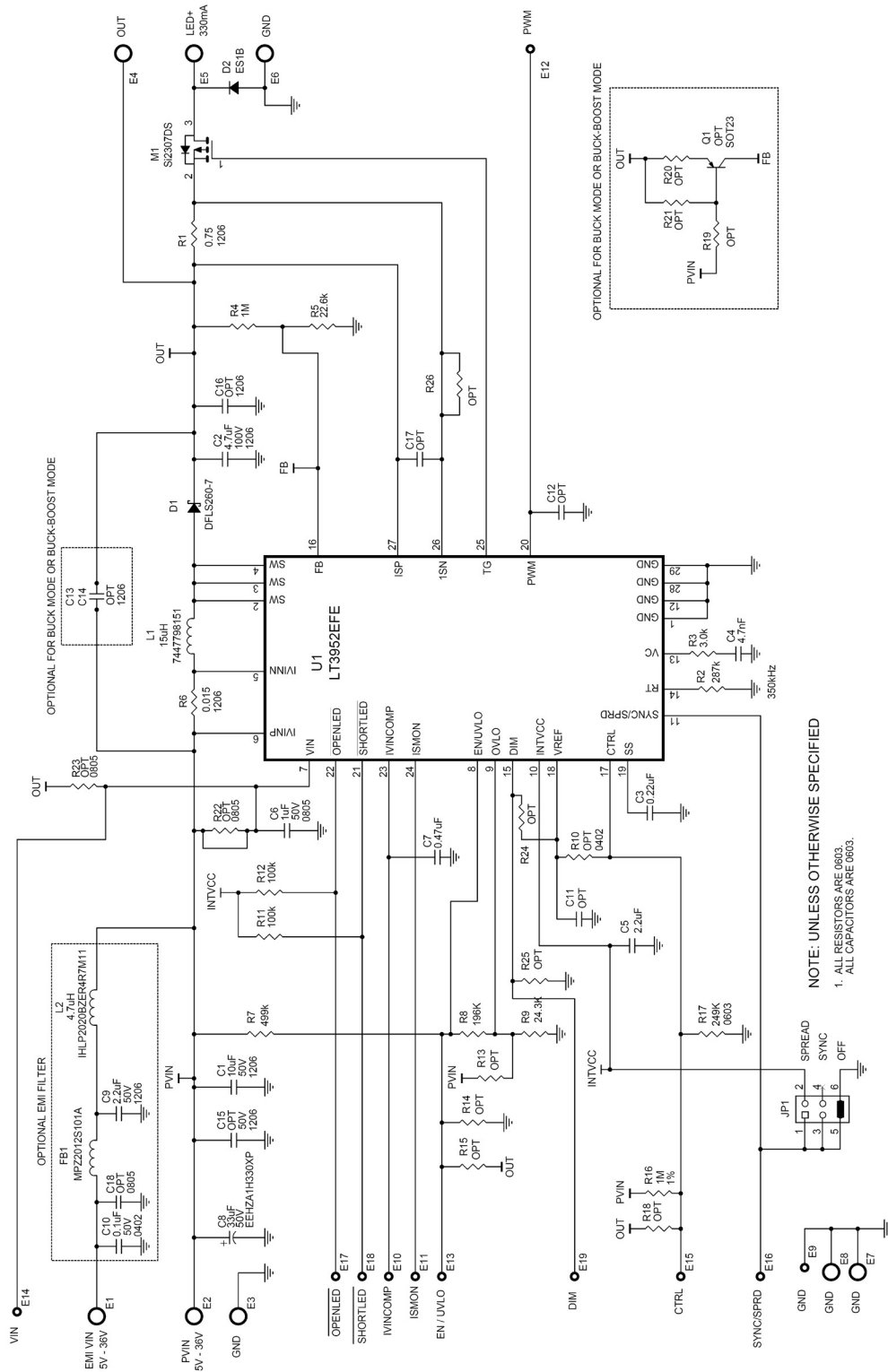

DEMO MANUAL DC2013A

DEMONSTRATION BOARD IMPORTANT NOTICE

Linear Technology Corporation (LTC) provides the enclosed product(s) under the following **AS IS** conditions:

This demonstration board (DEMO BOARD) kit being sold or provided by Linear Technology is intended for use for **ENGINEERING DEVELOPMENT OR EVALUATION PURPOSES ONLY** and is not provided by LTC for commercial use. As such, the DEMO BOARD herein may not be complete in terms of required design-, marketing-, and/or manufacturing-related protective considerations, including but not limited to product safety measures typically found in finished commercial goods. As a prototype, this product does not fall within the scope of the European Union directive on electromagnetic compatibility and therefore may or may not meet the technical requirements of the directive, or other regulations.

If this evaluation kit does not meet the specifications recited in the DEMO BOARD manual the kit may be returned within 30 days from the date of delivery for a full refund. **THE FOREGOING WARRANTY IS THE EXCLUSIVE WARRANTY MADE BY THE SELLER TO BUYER AND IS IN LIEU OF ALL OTHER WARRANTIES, EXPRESSED, IMPLIED, OR STATUTORY, INCLUDING ANY WARRANTY OF MERCHANTABILITY OR FITNESS FOR ANY PARTICULAR PURPOSE. EXCEPT TO THE EXTENT OF THIS INDEMNITY, NEITHER PARTY SHALL BE LIABLE TO THE OTHER FOR ANY INDIRECT, SPECIAL, INCIDENTAL, OR CONSEQUENTIAL DAMAGES.**

The user assumes all responsibility and liability for proper and safe handling of the goods. Further, the user releases LTC from all claims arising from the handling or use of the goods. Due to the open construction of the product, it is the user's responsibility to take any and all appropriate precautions with regard to electrostatic discharge. Also be aware that the products herein may not be regulatory compliant or agency certified (FCC, UL, CE, etc.).

No License is granted under any patent right or other intellectual property whatsoever. **LTC assumes no liability for applications assistance, customer product design, software performance, or infringement of patents or any other intellectual property rights of any kind.**

LTC currently services a variety of customers for products around the world, and therefore this transaction **is not exclusive**.

Please read the DEMO BOARD manual prior to handling the product. Persons handling this product must have electronics training and observe good laboratory practice standards. **Common sense is encouraged.**

This notice contains important safety information about temperatures and voltages. For further safety concerns, please contact a LTC application engineer.

Mailing Address:

Linear Technology
1630 McCarthy Blvd.
Milpitas, CA 95035

Copyright © 2004, Linear Technology Corporation

Компания «Life Electronics» занимается поставками электронных компонентов импортного и отечественного производства от производителей и со складов крупных дистрибьюторов Европы, Америки и Азии.

С конца 2013 года компания активно расширяет линейку поставок компонентов по направлению коаксиальный кабель, кварцевые генераторы и конденсаторы (керамические, пленочные, электролитические), за счёт заключения дистрибьюторских договоров

Мы предлагаем:

- Конкурентоспособные цены и скидки постоянным клиентам.
- Специальные условия для постоянных клиентов.
- Подбор аналогов.
- Поставку компонентов в любых объемах, удовлетворяющих вашим потребностям.
- Приемлемые сроки поставки, возможна ускоренная поставка.
- Доставку товара в любую точку России и стран СНГ.
- Комплексную поставку.
- Работу по проектам и поставку образцов.
- Формирование склада под заказчика.
- Сертификаты соответствия на поставляемую продукцию (по желанию клиента).
- Тестирование поставляемой продукции.
- Поставку компонентов, требующих военную и космическую приемку.
- Входной контроль качества.
- Наличие сертификата ISO.

В составе нашей компании организован Конструкторский отдел, призванный помогать разработчикам, и инженерам.

Конструкторский отдел помогает осуществить:

- Регистрацию проекта у производителя компонентов.
- Техническую поддержку проекта.
- Защиту от снятия компонента с производства.
- Оценку стоимости проекта по компонентам.
- Изготовление тестовой платы монтаж и пусконаладочные работы.



Тел: +7 (812) 336 43 04 (многоканальный)

Email: org@lifeelectronics.ru