

# Inductorless, Liquid Lens Driver Demoboard

## General Description

The HV892DB1 liquid lens driver demoboard is controlled via an I<sup>2</sup>C interface, is capable of driving capacitive loads of up to 200pF, and is compatible with 40V<sub>RMS</sub> to 60V<sub>RMS</sub> lenses.

A charge pump boost converter integrated on-chip provides the high voltage necessary for driving the lens. No external inductors or diodes are needed. The board requires only two ceramic chip capacitors to complete a lens driver circuit.

An H-bridge output stage provides AC drive to the lens, allowing the use of a single high voltage boost converter while providing alternating polarity to the lens. Controlled rising and falling edges on the drive waveform reduces EMI.

## Specifications

Parameter	Value
Supply voltage (V <sub>IN</sub> ):	2.65 – 5.50V
Supply current (I <sub>IN</sub> ):	20mA max operating 500nA max standby
Output voltage (OUT1 – OUT2):	9.8 – 62.6V <sub>RMS</sub> , adjustable via I <sup>2</sup> C
Load (lens) capacitance:	100 – 200pF
I <sup>2</sup> C reference voltage (V <sub>DD</sub> ):	1.70 – 2.95V
I <sup>2</sup> C clock:	400kHz max
I <sup>2</sup> C address (7-bit):	0100011b
Board dimensions:	35.6mm x 26.2mm

## Board Layout and Connections

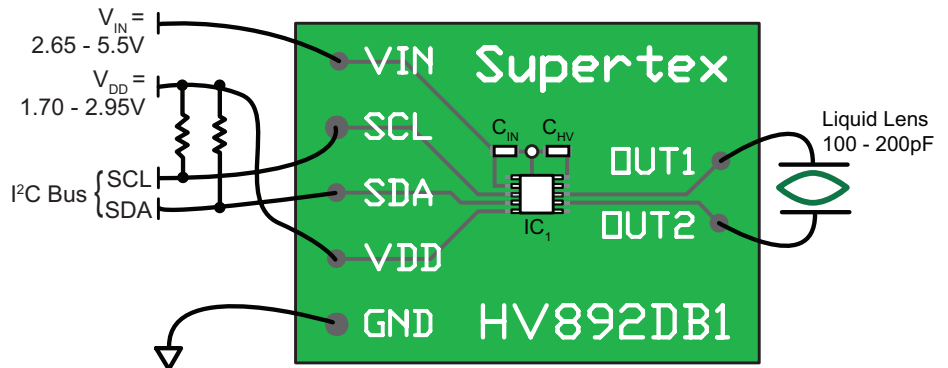
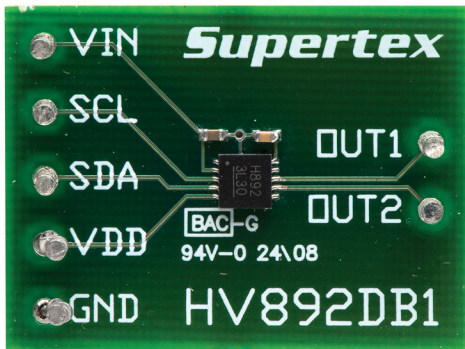

### Connections:

**VIN**  
Supply voltage to the HV892. Externally supplied V<sub>IN</sub> should be between 2.65 and 5.50V.

**GND**  
Circuit common.

**VDD**  
Externally supplied logic reference voltage for the I<sup>2</sup>C interface. V<sub>DD</sub> should be between 1.70 and 2.95V.

**SCL**  
I<sup>2</sup>C clock. Clock frequency should be no greater than 400kHz.

**SDA**  
I<sup>2</sup>C data.

**OUT1 and OUT2**  
The lens driver output. Connect the lens between these two terminals. Load (lens) capacitance should be between 100 and 200pF, including any stray capacitance.

**Note:**  
*The resistors shown in the connection diagram are the normal I<sup>2</sup>C pull-ups. No additional pull-ups are required.*

## HV892DB1 Circuit Schematic

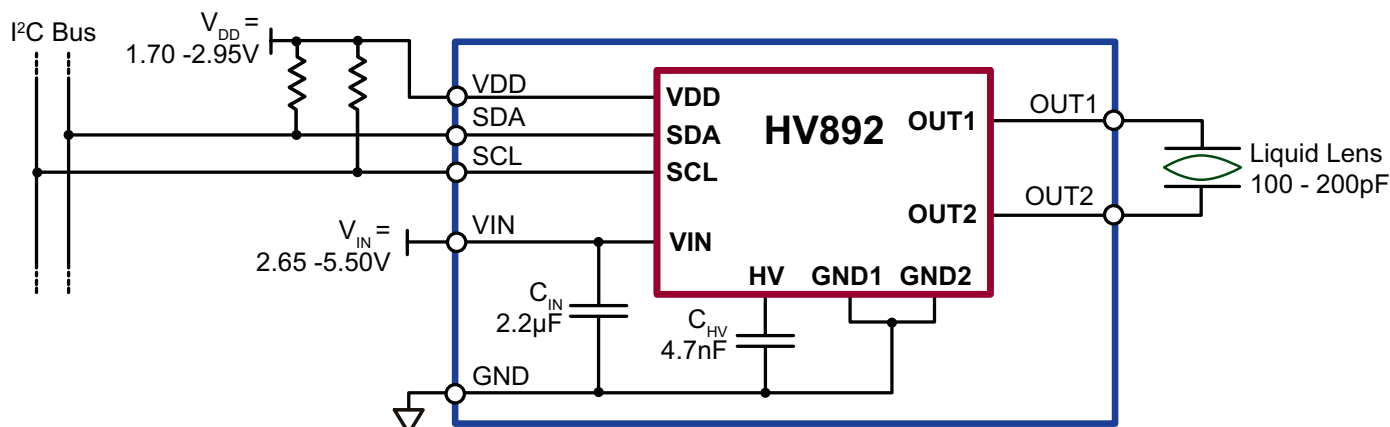

## Bill of Materials

Part	Description	Value	Tolerance	Rating	Package	Manufacturer	Part Number
C <sub>IN</sub>	Ceramic capacitor	2.2µF	20%	6.3V	0603	Any	---
C <sub>HV</sub>	Ceramic capacitor	4.7nF	10%	100V	0603	Any	---
IC <sub>1</sub>	Lens driver	-	-	-	4x4 DFN	Supertex	HV892K7-G

## Operation

A single byte (AMP) written to the HV892 controls the operation of the driver. Setting AMP = 00h causes the HV892 to go into low power standby mode. Setting AMP = 01h to FFh controls output amplitude in 255 monotonic steps.

$$V_{OUT(RMS)} = 9.6V_{RMS} + AMP \cdot 208mV_{RMS}$$

The HV892 is write-only. No readback of the AMP byte is possible.

The HV892's 7-bit address is 0100011b. For large quantity orders, other 7-bit addresses may be obtained.

The resistors shown on the above schematic are the I<sup>2</sup>C bus' normal pull-ups. No additional pull-ups are required. Externally supplied V<sub>DD</sub> is the I<sup>2</sup>C bus' reference voltage.

Externally supplied V<sub>IN</sub> should be ramped up in less than 2.0ms to ensure the driver starts-up in standby mode. If brought up slower, the driver may not start-up in standby mode, with output amplitude at an indeterminate level. In this case, writing AMP = 00h brings the driver to standby mode. No damage will occur if V<sub>IN</sub> is brought up slower than 2.0ms.

Light capacitive loads may result in waveform distortion. This is due to the output pins being held at a high-Z state for a portion of the waveform. Without adequate capacitance to hold up the voltage, some droop may be observed when DC-loaded by oscilloscope probes.

To avoid loading down the outputs, use instruments having at least 10MΩ input impedance when taking measurements. While many voltmeters may have a very high input resistance on the DC scale, they frequently have only 1.0MΩ input impedance on the AC scale. Also, be sure to use a voltmeter with true RMS capability.

**Supertex inc.** does not recommend the use of its products in life support applications, and will not knowingly sell them for use in such applications unless it receives an adequate "product liability indemnification insurance agreement." **Supertex inc.** does not assume responsibility for use of devices described, and limits its liability to the replacement of the devices determined defective due to workmanship. No responsibility is assumed for possible omissions and inaccuracies. Circuitry and specifications are subject to change without notice. For the latest product specifications refer to the **Supertex inc.** (website: <http://www.supertex.com>)

Компания «Life Electronics» занимается поставками электронных компонентов импортного и отечественного производства от производителей и со складов крупных дистрибьюторов Европы, Америки и Азии.

С конца 2013 года компания активно расширяет линейку поставок компонентов по направлению коаксиальный кабель, кварцевые генераторы и конденсаторы (керамические, пленочные, электролитические), за счёт заключения дистрибьюторских договоров

Мы предлагаем:

- Конкурентоспособные цены и скидки постоянным клиентам.
- Специальные условия для постоянных клиентов.
- Подбор аналогов.
- Поставку компонентов в любых объемах, удовлетворяющих вашим потребностям.
- Приемлемые сроки поставки, возможна ускоренная поставка.
- Доставку товара в любую точку России и стран СНГ.
- Комплексную поставку.
- Работу по проектам и поставку образцов.
- Формирование склада под заказчика.
- Сертификаты соответствия на поставляемую продукцию (по желанию клиента).
- Тестирование поставляемой продукции.
- Поставку компонентов, требующих военную и космическую приемку.
- Входной контроль качества.
- Наличие сертификата ISO.

В составе нашей компании организован Конструкторский отдел, призванный помогать разработчикам, и инженерам.

Конструкторский отдел помогает осуществить:

- Регистрацию проекта у производителя компонентов.
- Техническую поддержку проекта.
- Защиту от снятия компонента с производства.
- Оценку стоимости проекта по компонентам.
- Изготовление тестовой платы монтаж и пусконаладочные работы.



Тел: +7 (812) 336 43 04 (многоканальный)

Email: [org@lifeelectronics.ru](mailto:org@lifeelectronics.ru)