

XBP06V1E4MR-G

ETR2901-004

Transient Voltage Suppressor (TVS)

GENERAL DESCRIPTION

Four elements in SOT-25 package (Anode Common)

High ESD

APPLICATIONS

ESD protection

ABSOLUTE MAXIMUM RATINGS

Ta=25°C

PARAMETER	SYMBOL	RATINGS	UNITS
Peak Pulse Power ^(*1)	Ppk	200	W
Power Dissipation	Pd	250	mW
		750 ^(*2)	
Junction Temperature	Tj	150	°C
Storage Temperature Range	Tstg	-55~+150	°C
ESD Durability ^{(*3)(*4)}	Vpp	30	kV
Contact Discharge			

(*1): tp=8/20 μs

(*2): This is a reference data taken by using the test board.

(*3): Test Condition IEC61000-4-2 Standard

(*4): Criterion: No damage to device elements

MARKING RULE

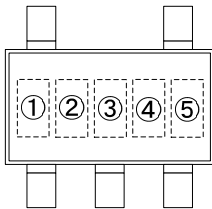

: BP3(Product Number)

: Lot Number

PIN CONFIGURATION

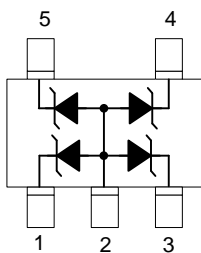

TOP VIEW

1. Cathode
2. Anode
3. Cathode
4. Cathode
5. Cathode

PACKAGING INFORMATION

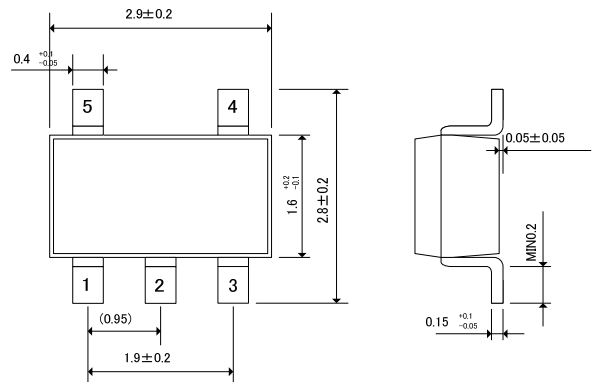

(unit : mm)

SOT-25 Package

PRODUCT NAME	PACKAGE	ORDER UNIT
XBP06V1E4MR-G*	SOT-25	3,000/Reel

* The "-G" suffix indicates that the products are Halogen and Antimony free as well as being fully RoHS compliant.

ELECTRICAL CHARACTERISTICS

Ta=25°C

PARAMETER	SYMBOL	TEST CONDITION	LIMITS			UNITS
			MIN.	TYP.	MAX.	
Breakdown Voltage	V _{BR}	I _R = 1mA	6.1	6.65	7.2	V
Leakage Current	I _{RM}	V _{RM} = 5.25V	-	-	2.5	μA
Forward Voltage	V _F	I _F = 200mA	-	-	1.25	V
Inter-Terminal Capacity	C _t	V _R = 0V, f = 1MHz	-	170	-	pF

TYPICAL PERFORMANCE CHARACTERISTICS

(1) Reverse Current vs. Breakdown Voltage

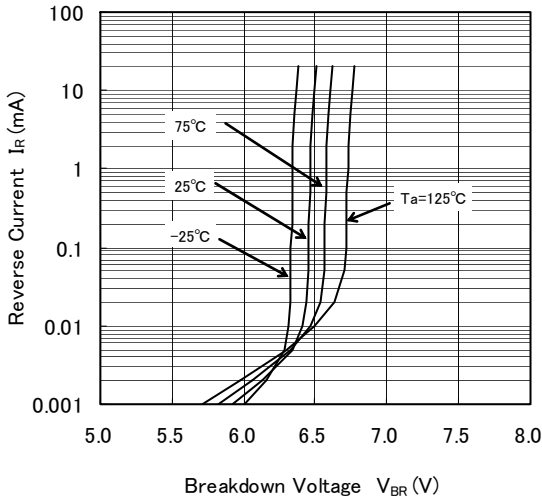

(2) Reverse Current vs. Reverse Voltage

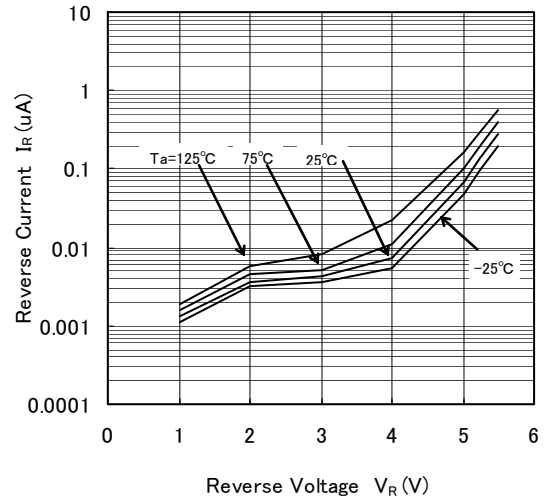

(3) Breakdown Voltage vs. Operating Temperature

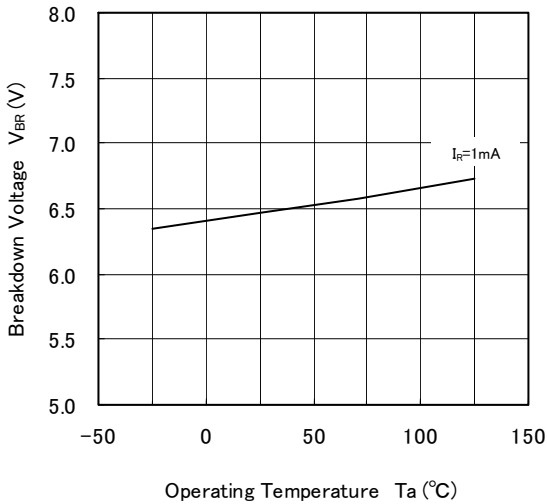

(4) Reverse Current vs. Operating Temperature

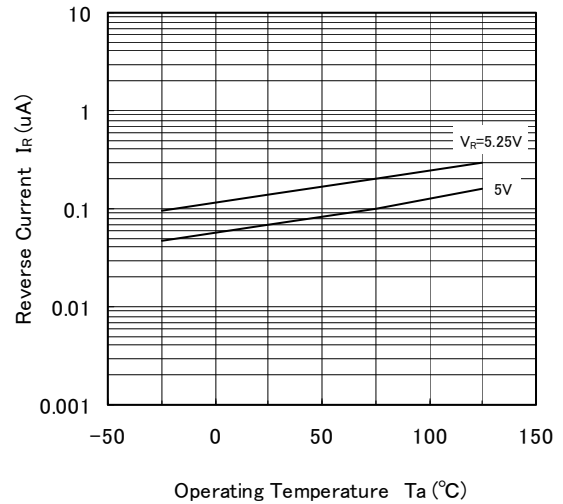

(5) Inter-Terminal Capacity vs. Reverse Voltage

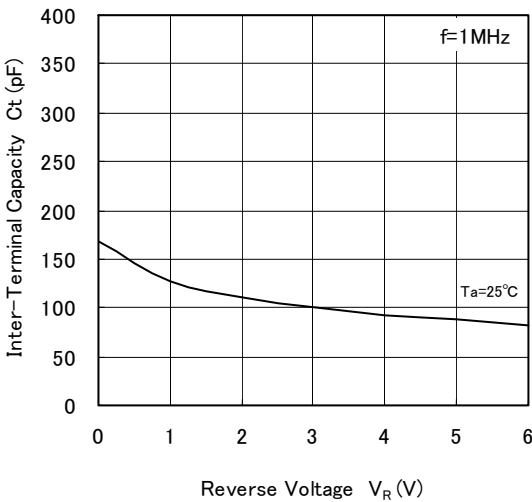

(6) Forward Current vs. Forward Voltage

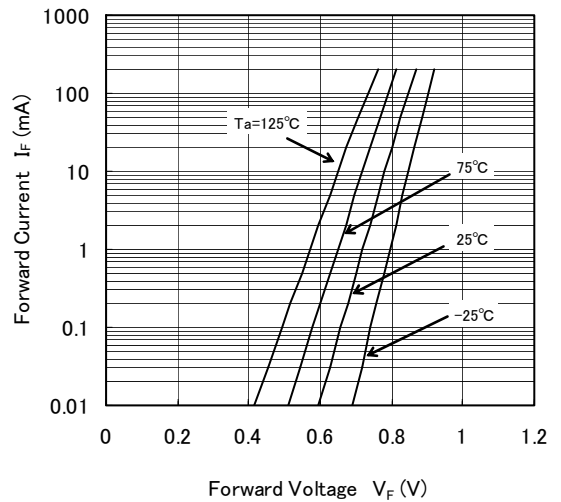

PACKAGING INFORMATION

SOT-25 Power Dissipation

Power dissipation data for the SOT-25 is shown in this page.
 The value of power dissipation varies with the mount board conditions.
 Please use this data as one of reference data taken in the described condition.

1. Measurement Condition (Reference data)

- Condition: Mount on a board
- Ambient: Natural convection
- Soldering: Lead (Pb) free
- Board: Dimensions 40 x 40 mm (1600 mm² in one side)
 Copper (Cu) traces occupy 50% of the board area
 In top and back faces
 Package heat-sink is tied to the copper traces
 (Board of SOT-26 is used.)
- Material: Glass Epoxy (FR-4)
- Thickness: 1.6 mm
- Through-hole: 4 x 0.8 Diameter

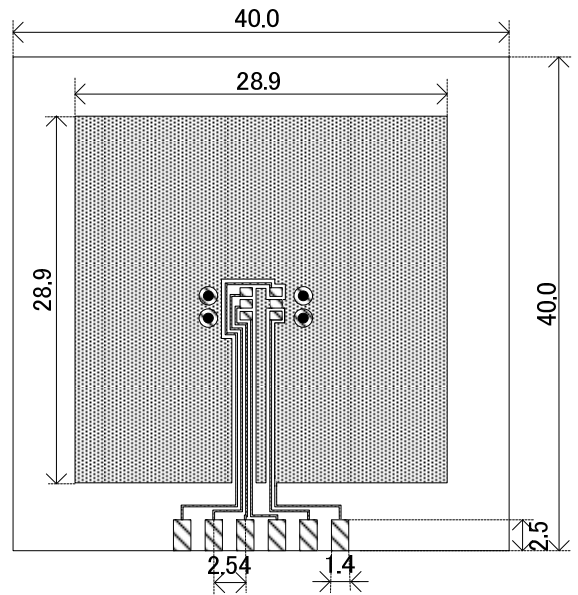

Evaluation Board (Unit: mm)

2. Power Dissipation vs. Operating temperature

Board Mount (T_j max = 150 °C)

Ambient Temperature (°C)	Power Dissipation Pd (mW)	Thermal Resistance (°C/W)
25	750	166.67
105	270	

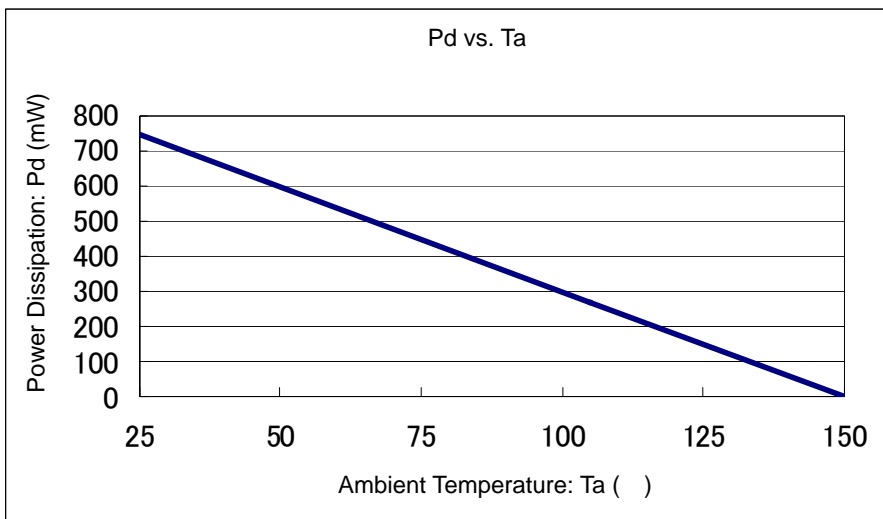

1. The products and product specifications contained herein are subject to change without notice to improve performance characteristics. Consult us, or our representatives before use, to confirm that the information in this datasheet is up to date.
2. We assume no responsibility for any infringement of patents, patent rights, or other rights arising from the use of any information and circuitry in this datasheet.
3. Please ensure suitable shipping controls (including fail-safe designs and aging protection) are in force for equipment employing products listed in this datasheet.
4. The products in this datasheet are not developed, designed, or approved for use with such equipment whose failure or malfunction can be reasonably expected to directly endanger the life of, or cause significant injury to, the user.
(e.g. Atomic energy; aerospace; transport; combustion and associated safety equipment thereof.)
5. Please use the products listed in this datasheet within the specified ranges.
Should you wish to use the products under conditions exceeding the specifications, please consult us or our representatives.
6. We assume no responsibility for damage or loss due to abnormal use.
7. All rights reserved. No part of this datasheet may be copied or reproduced without the prior permission of TOREX SEMICONDUCTOR LTD.

TOREX SEMICONDUCTOR LTD.

Компания «Life Electronics» занимается поставками электронных компонентов импортного и отечественного производства от производителей и со складов крупных дистрибьюторов Европы, Америки и Азии.

С конца 2013 года компания активно расширяет линейку поставок компонентов по направлению коаксиальный кабель, кварцевые генераторы и конденсаторы (керамические, пленочные, электролитические), за счёт заключения дистрибьюторских договоров

Мы предлагаем:

- Конкурентоспособные цены и скидки постоянным клиентам.
- Специальные условия для постоянных клиентов.
- Подбор аналогов.
- Поставку компонентов в любых объемах, удовлетворяющих вашим потребностям.
- Приемлемые сроки поставки, возможна ускоренная поставка.
- Доставку товара в любую точку России и стран СНГ.
- Комплексную поставку.
- Работу по проектам и поставку образцов.
- Формирование склада под заказчика.
- Сертификаты соответствия на поставляемую продукцию (по желанию клиента).
- Тестирование поставляемой продукции.
- Поставку компонентов, требующих военную и космическую приемку.
- Входной контроль качества.
- Наличие сертификата ISO.

В составе нашей компании организован Конструкторский отдел, призванный помогать разработчикам, и инженерам.

Конструкторский отдел помогает осуществить:

- Регистрацию проекта у производителя компонентов.
- Техническую поддержку проекта.
- Защиту от снятия компонента с производства.
- Оценку стоимости проекта по компонентам.
- Изготовление тестовой платы монтаж и пусконаладочные работы.



Тел: +7 (812) 336 43 04 (многоканальный)

Email: org@lifeelectronics.ru