

S1D13700 Embedded Memory Graphics LCD Controller

The S1D13700 Embedded Memory Graphics LCD Controller can display both text and graphics on an LCD panel. The S1D13700 allows layered text and graphics, scrolling of the display in any direction, and partitioning of the display into multiple screens. It includes 32K bytes of embedded SRAM display memory which is used to store text, character codes, and bit-mapped graphics. The S1D13700 handles display controller functions including: transferring data from the controlling microprocessor to the buffer memory, reading memory data, converting data to display pixels, and generating timing signals for the LCD panel.

The S1D13700 is designed with an internal character generator which supports 160, 5x7 pixel characters in internal mask ROM (CGROM) and 64, 8x8 pixel characters in character generator RAM (CGRAM). When the CGROM is not used, up to 256, 8x16 pixel characters are supported in CGRAM.

Designed as a functional replacement to the S1D13305, the S1D13700 has an expanded feature set which includes; direct support of the Motorola MC68K microprocessor family, embedded display buffer, increased clock speeds, increased grayscale depths, lower power technology and smaller packages.

■ FEATURES

CPU Interface

- 8-bit CPU data bus interface
- Direct Address Bus support for:
 - Generic (Z80/8080 family) bus interface
 - Motorola MC68K family bus interface
- Indirect Address Bus support for:
 - Generic (Z80/8080 family) bus interface
 - Motorola MC68K family bus interface
 - Motorola M6800 family bus interface

Memory Interface

- Embedded 32K byte SRAM display buffer

Display Support

- 4-bit monochrome LCD interface
- Programmable Display Resolutions:

Typical resolutions include:

640x240 at 1 bpp
320x240 at 2 bpp
240x160 at 4 bpp

- 1/2-duty to 1/256-duty LCD drive

Character Generation

- 160, 5x7 pixel characters in embedded mask-programmed character generator ROM
- Up to 256, 8x16 pixel characters in embedded character generator RAM

Display Modes

- Gray Shade Support for:
 - 1/2/4 bit-per-pixel (up to 16 gray shades)
- Text, graphics, and combined text/graphics display modes
- Three overlapping screens in graphics mode
- Programmable cursor control (Hardware Cursor)
- Smooth horizontal and vertical scrolling of all or part of the display

Power

- Software initiated Power Save Mode
- Low power consumption
- Flexible Power Supply configuration:

CORE V_{DD} 3.0 to 3.6 volts.
NIO V_{DD} 3.0 to 5.5 volts (LCD interface).
HIO V_{DD} 3.0 to 5.5 volts (CPU interface).

Clock Source

- Two terminal crystal or Single Oscillator input
Input clock maximum of 60MHz

Package

- TQFP13-64pin

S1D13700

SYSTEM BLOCK DIAGRAM

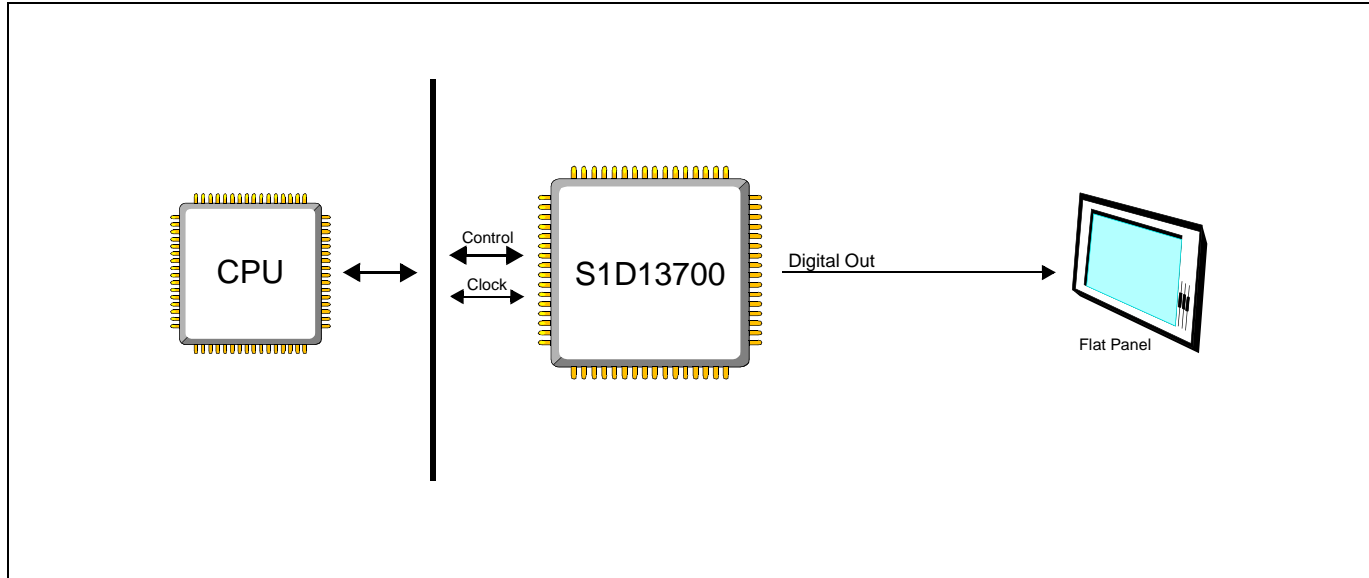

CONTACT YOUR SALES REPRESENTATIVE FOR THESE COMPREHENSIVE DESIGN TOOLS:

- S1D13700 Technical Manual
- S1D13700 Evaluation Boards
- Software Utilities

Japan

Seiko Epson Corporation
 IC International Sales Group
 421-8, Hino, Hino-shi
 Tokyo 191-8501, Japan
 Tel: 042-587-5812
 Fax: 042-587-5564
<http://www.epson.co.jp/>

Hong Kong

Epson Hong Kong Ltd.
 20/F., Harbour Centre
 25 Harbour Road
 Wanchai, Hong Kong
 Tel: 2585-4600
 Fax: 2827-4346
<http://www.epson.com.hk/>

North America

Epson Electronics America, Inc.
 2580 Orchard Parkway
 San Jose, CA 95131, USA
 Tel: (408) 922-0200
 Fax: (408) 922-0238
<http://www.eea.epson.com/>

Europe

Epson Europe Electronics GmbH
 Riesstrasse 15
 80992 Munich, Germany
 Tel: 089-14005-0
 Fax: 089-14005-110
<http://www.epson-electronics.de/>

Taiwan

Epson Taiwan Technology & Trading Ltd.
 14F, No. 7
 Song Ren Road
 Taipei 110
 Tel: 02-8786-6688
 Fax: 02-8786-6677
<http://www.epson.com.tw/>

Singapore

Epson Singapore Pte Ltd
 1 HarbourFront Place #03-02
 HarbourFront Tower One
 Singapore, 098633
 Tel: (65) 6586-5500
 Fax: (65) 6271-3182
<http://www.epson.com.sg/>

© SEIKO EPSON CORPORATION 2004-2007. All rights reserved.
 Information in this document is subject to change without notice. You may download and use this document, but only for your own use in evaluating Seiko Epson/EPSON products. You may not modify the document. Epson Research and Development, Inc. disclaims any representation that the contents of this document are accurate or current. The Programs/Technologies described in this document may contain material protected under U.S. and/or International Patent laws. EPSON is a registered trademark of Seiko Epson Corporation. All other trademarks are the property of their respective owners.

Компания «Life Electronics» занимается поставками электронных компонентов импортного и отечественного производства от производителей и со складов крупных дистрибьюторов Европы, Америки и Азии.

С конца 2013 года компания активно расширяет линейку поставок компонентов по направлению коаксиальный кабель, кварцевые генераторы и конденсаторы (керамические, пленочные, электролитические), за счёт заключения дистрибьюторских договоров

Мы предлагаем:

- Конкуренспособные цены и скидки постоянным клиентам.
- Специальные условия для постоянных клиентов.
- Подбор аналогов.
- Поставку компонентов в любых объемах, удовлетворяющих вашим потребностям.
- Приемлемые сроки поставки, возможна ускоренная поставка.
- Доставку товара в любую точку России и стран СНГ.
- Комплексную поставку.
- Работу по проектам и поставку образцов.
- Формирование склада под заказчика.
- Сертификаты соответствия на поставляемую продукцию (по желанию клиента).
- Тестирование поставляемой продукции.
- Поставку компонентов, требующих военную и космическую приемку.
- Входной контроль качества.
- Наличие сертификата ISO.

В составе нашей компании организован Конструкторский отдел, призванный помогать разработчикам, и инженерам.

Конструкторский отдел помогает осуществить:

- Регистрацию проекта у производителя компонентов.
- Техническую поддержку проекта.
- Защиту от снятия компонента с производства.
- Оценку стоимости проекта по компонентам.
- Изготовление тестовой платы монтаж и пусконаладочные работы.



Тел: +7 (812) 336 43 04 (многоканальный)
Email: org@lifeelectronics.ru