

**PRELIMINARY**

LuxiGen™ Violet LED Emitter Series  
LZ1 395nm Power

# LZ1-00UAP5



## Key Features

- Highest Radiant Flux density 395nm LED emitter: 4.1W flux output from 1mm<sup>2</sup> chip
- Up to 3A max drive current
- Compact footprint – 4.4mm x 4.4mm
- Surface mount ceramic package with integrated glass lens
- Lowest thermal resistance (2.7°C/W)
- Electrically neutral thermal path
- JEDEC Level 1 for Moisture Sensitivity Level
- Lead (Pb) free and RoHS compliant
- Emitter available on Star MCPCB (optional)

## Typical Applications

- Ink and adhesive curing

## Description

The LZ1-00UAP5 395nm Power LED emitter provides exceptionally high radiant power density from a compact 4.4mm x 4.4mm footprint. It delivers more than double the flux from a typical single die 395nm LED emitter which resulted in significantly reduced curing time. With its ultra-low thermal resistance of 2.7C/W, it allows heat to be dissipated efficiently out of die optimizing the overall light output. The glass lens used in the package is chosen for its optical efficiency and robustness in harsh UV curing environment.

## Notes

This product emits UV light. Please observe precaution given in the IEC 62471 Risk Group 3 when operating this product. Avoid eye and skin exposure to unshielded product.



## Part number options

### Base part number

Part number	Description
LZ1-00UAP5-xxxx	LZ1 emitter
LZ1-U0UAP5-xxxx	LZ1 emitter on Standard Star MCPCB

### Bin kit option codes

#### Single wavelength bin (5nm range)

Kit number suffix	Min flux Bin	Color Bin Range	Description
00U5	N22	U5	N22 minimum flux; wavelength U5 bin only

## Radiant Flux Bins

Table 1:

Bin Code	Minimum Radiant Flux ( $\Phi$ ) @ $I_F = 1000\text{mA}$ <sup>[1]</sup> (W)	Maximum Radiant Flux ( $\Phi$ ) @ $I_F = 1000\text{mA}$ <sup>[1]</sup> (W)
N22	1.42	1.60
P	1.60	2.00

Notes for Table 1:

1. Radiant flux performance is measured at specified current, 10ms pulse width,  $T_c = 25^\circ\text{C}$ . LED Engin maintains a tolerance of  $\pm 10\%$  on flux measurements.

## Peak Wavelength Bins

Table 2:

Bin Code	Minimum Peak Wavelength ( $\lambda_p$ ) @ $I_F = 1000\text{mA}$ <sup>[1]</sup> (nm)	Maximum Peak Wavelength ( $\lambda_p$ ) @ $I_F = 1000\text{mA}$ <sup>[1]</sup> (nm)
U5	390	395

Notes for Table 2:

1. Peak wavelength is measured at specified current, 10ms pulse width,  $T_c = 25^\circ\text{C}$ . LED Engin maintains a tolerance of  $\pm 2.0\text{nm}$  on peak wavelength measurements.

## Forward Voltage Bins

Table 3:

Bin Code	Minimum Forward Voltage ( $V_F$ ) @ $I_F = 1000\text{mA}$ <sup>[1]</sup> (V)	Maximum Forward Voltage ( $V_F$ ) @ $I_F = 1000\text{mA}$ <sup>[1]</sup> (V)
0	3.1	4.1

Notes for Table 3:

1. Forward voltage is measured at specified current, 10ms pulse width,  $T_c = 25^\circ\text{C}$ . LED Engin maintains a tolerance of  $\pm 0.04\text{V}$  for forward voltage measurements.

## Absolute Maximum Ratings

Table 4:

Parameter	Symbol	Value	Unit
DC Forward Current <sup>[1]</sup>	$I_F$	3000	mA
Peak Pulsed Forward Current <sup>[2]</sup>	$I_{FP}$	3000	mA
Reverse Voltage	$V_R$	See Note 3	V
Storage Temperature	$T_{stg}$	-40 ~ +150	°C
Junction temperature (operational)	$T_{J(MAX)_ops}$	100	°C
Junction Temperature (absolute)	$T_{J(MAX)}$	125	°C
Soldering Temperature <sup>[4]</sup>	$T_{sol}$	260	°C

Notes for Table 4:

- Maximum DC forward current is determined by the overall thermal resistance and ambient temperature. Follow the curves in Figure 11 for current derating.
- Pulse forward current conditions: Pulse Width  $\leq$  10msec and Duty Cycle  $\leq$  10%.
- LEDs are not designed to be reverse biased.
- Solder conditions per JEDEC 020D. See Reflow Soldering Profile Figure 3
- LED Engin recommends taking reasonable precautions towards possible ESD damages and handling the LZ1-00UAP5 in an electrostatic protected area (EPA). An EPA may be adequately protected by ESD controls as outlined in ANSI/ESD S6.1.

## Optical Characteristics @ $T_C = 25^\circ\text{C}$

Table 5:

Parameter	Symbol	Typical	Unit
Radiant Flux (@ $I_F = 1000\text{mA}$ )	$\Phi$	1.7	W
Radiant Flux (@ $I_F = 3000\text{mA}$ )	$\Phi$	4.1	W
Peak Wavelength <sup>[1]</sup>	$\lambda_p$	393	nm
Viewing Angle <sup>[2]</sup>	$2\theta_{1/2}$	85	Degrees
Total Included Angle <sup>[3]</sup>	$\theta_{0.9V}$	125	Degrees

Notes for Table 5:

- Please observe precaution given in the IEC 62471 Risk Group 3 when operating this product. Avoid eye and skin exposure to unshielded product.
- Viewing Angle is the off axis angle from emitter centerline where the radiometric power is  $\frac{1}{2}$  of the peak value.
- Total Included Angle is the total angle that includes 90% of the total radiant flux.

## Electrical Characteristics @ $T_C = 25^\circ\text{C}$

Table 6:

Parameter	Symbol	Typical	Unit
Forward Voltage (@ $I_F = 1000\text{mA}$ )	$V_F$	3.4	V
Forward Voltage (@ $I_F = 3000\text{mA}$ )	$V_F$	3.7	V
Temperature Coefficient of Forward Voltage	$\Delta V_F / \Delta T_J$	-1.4	mV/°C
Thermal Resistance (Junction to Case)	$R\theta_{J-C}$	2.7	°C/W

## IPC/JEDEC Moisture Sensitivity Level

Table 7 - IPC/JEDEC J-STD-20D.1 MSL Classification:

Level	Soak Requirements					
	Floor Life		Standard		Accelerated	
	Time	Conditions	Time (hrs)	Conditions	Time (hrs)	Conditions
1	Unlimited	≤ 30°C/ 85% RH	168 +5/-0	85°C/ 85% RH	n/a	n/a

Notes for Table 7:

1. The standard soak time includes a default value of 24 hours for semiconductor manufacturer's exposure time (MET) between bake and bag and the floor life of maximum time allowed out of the bag at the end user of distributor's facility.

## Mechanical Dimensions (mm)

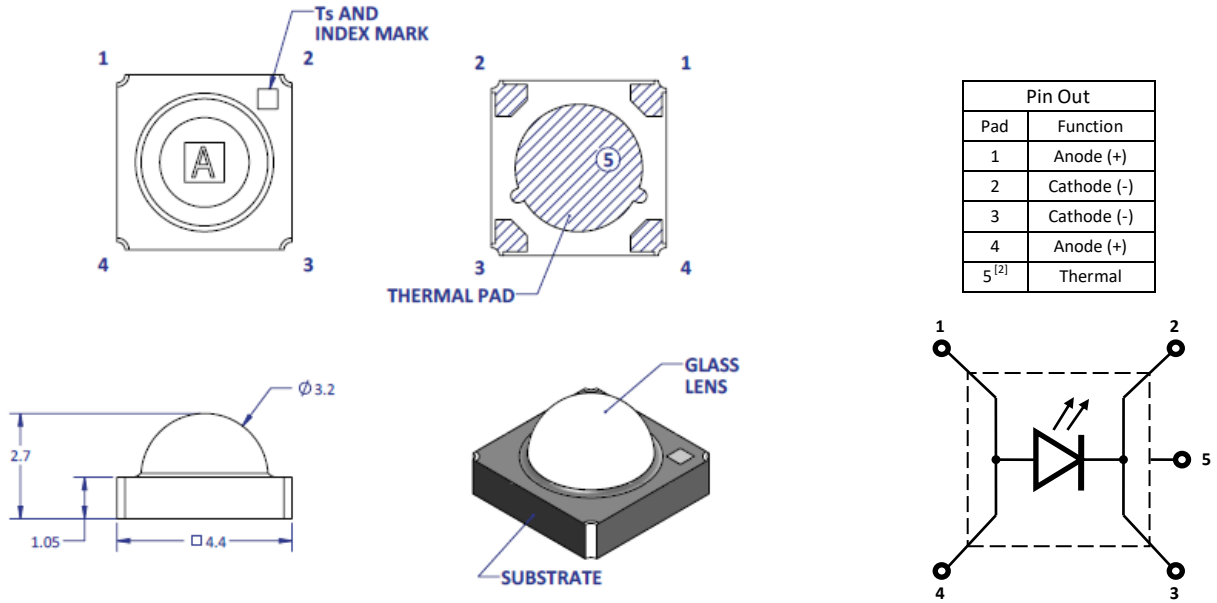

Figure 1: Package outline drawing.

### Notes for Figure 1:

1. Unless otherwise noted, the tolerance =  $\pm 0.20$  mm.
2. Thermal contact, Pad 5, is electrically neutral.
3. Tc point = index mark

## Recommended Solder Pad Layout (mm)

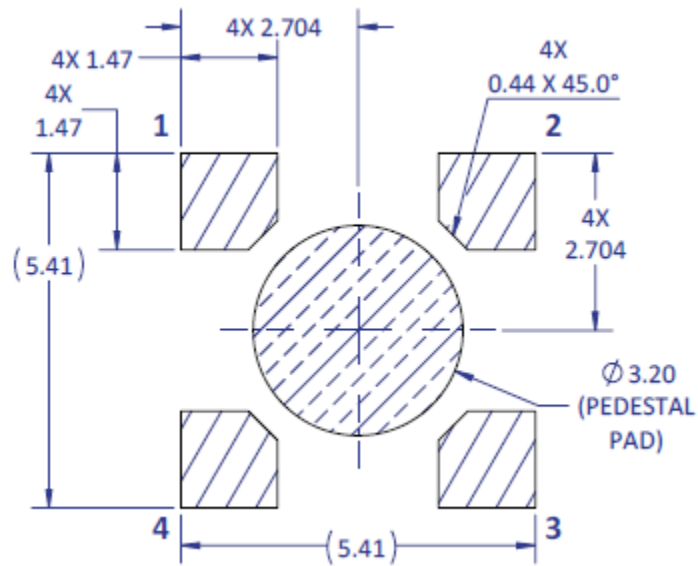

Figure 2a: Recommended solder pad layout for anode, cathode, and thermal pad for pedestal design

### Note for Figure 2a:

1. Unless otherwise noted, the tolerance =  $\pm 0.20$  mm.
2. Pedestal MCPCB allows the emitter thermal slug to be soldered directly to the metal core of the MCPCB. Such MCPCB eliminate the high thermal resistance dielectric layer that standard MCPCB technologies use in between the emitter thermal slug and the metal core of the MCPCB, thus lowering the overall system thermal resistance.
3. LED Engin recommends x-ray sample monitoring for solder voids underneath the emitter thermal slug. The total area covered by solder voids should be less than 20% of the total emitter thermal slug area. Excessive solder voids will increase the emitter to MCPCB thermal resistance and may lead to higher failure rates due to thermal over stress.

## Recommended Solder Mask Layout (mm)

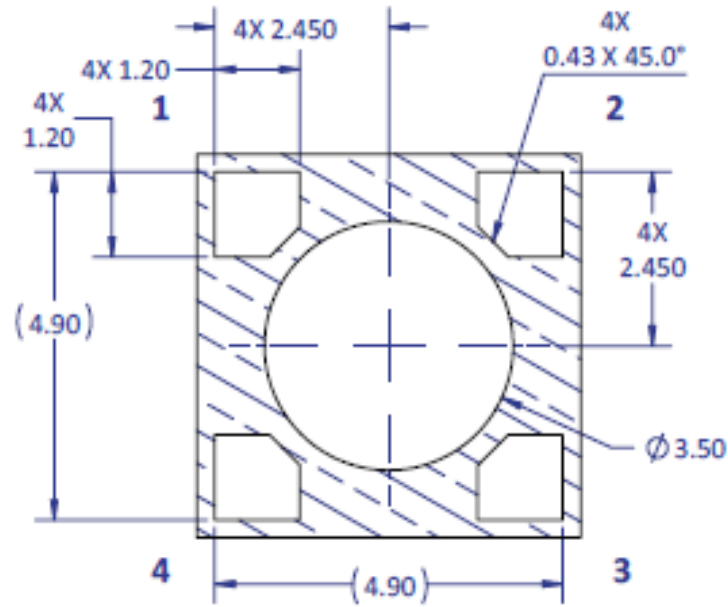

Figure 2b: Recommended solder mask opening for anode, cathode, and thermal pad for pedestal design

Note for Figure 2b:

1. Unless otherwise noted, the tolerance =  $\pm 0.20$  mm.

## Recommended 8mil Stencil Apertures Layout (mm)

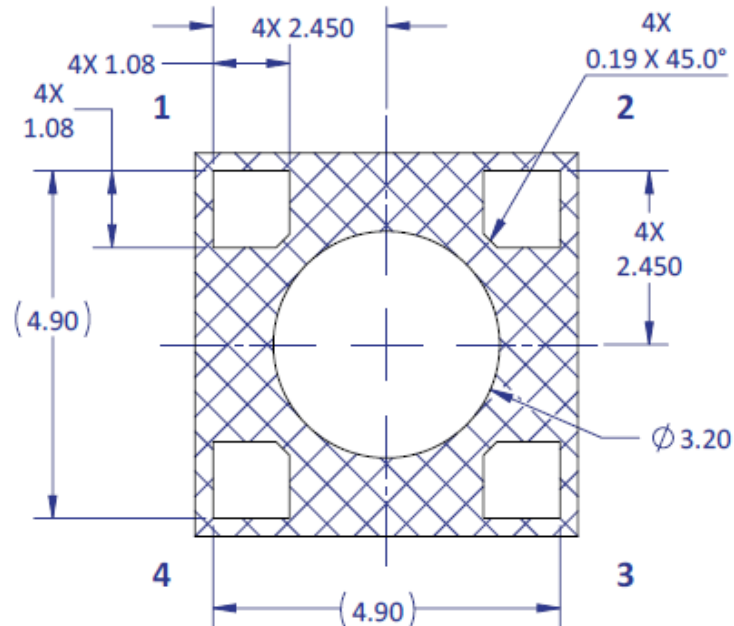

Figure 2c: Recommended solder mask opening for anode, cathode, and thermal pad for pedestal design

Note for Figure 2c:

1. Unless otherwise noted, the tolerance =  $\pm 0.20$  mm.

### Reflow Soldering Profile

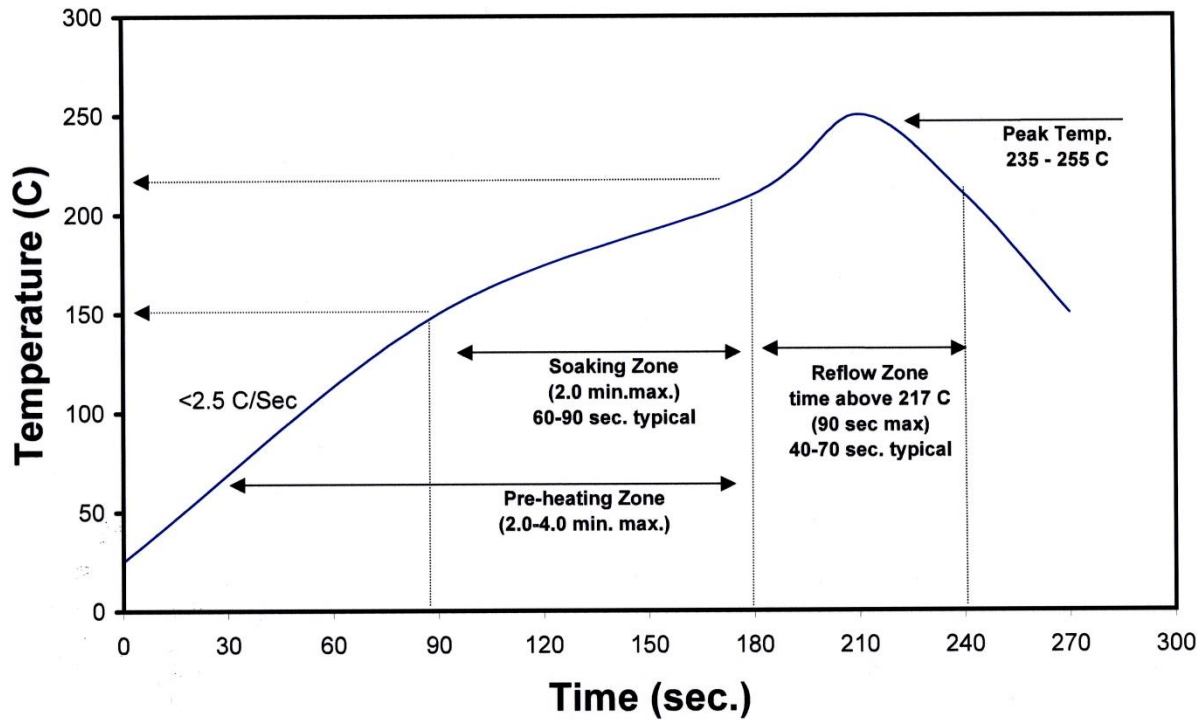

Figure 3: Reflow soldering profile for lead free soldering.

### Typical Radiation Pattern

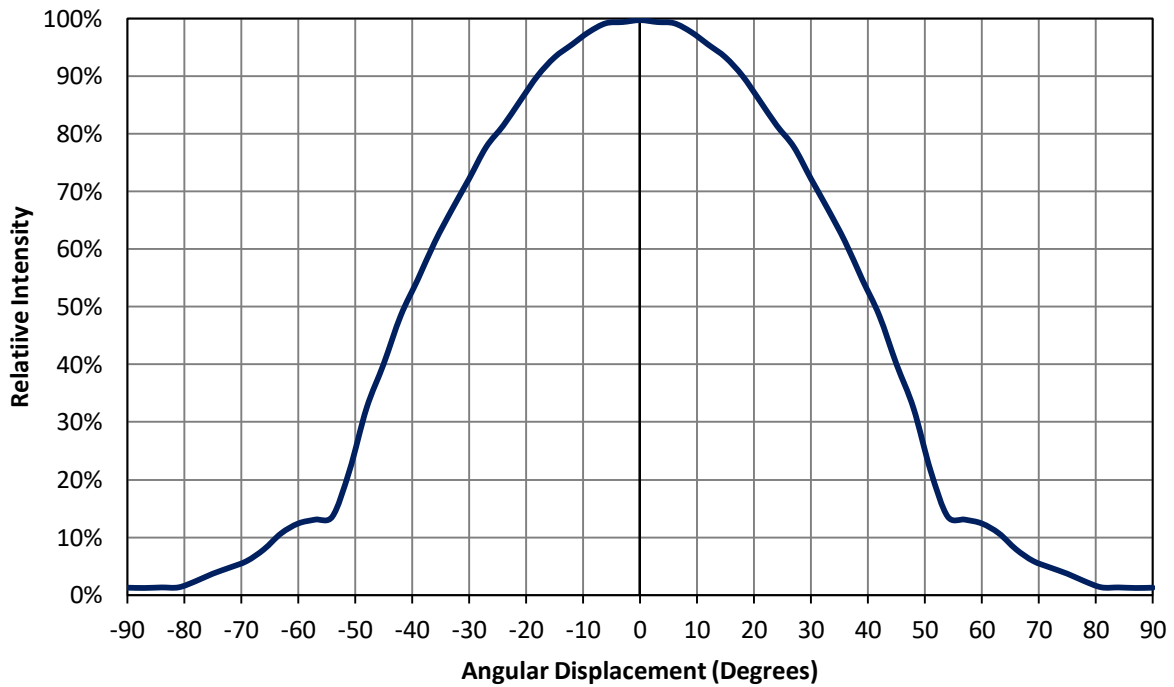

Figure 4: Typical representative spatial radiation pattern



### Typical Relative Spectral Power Distribution

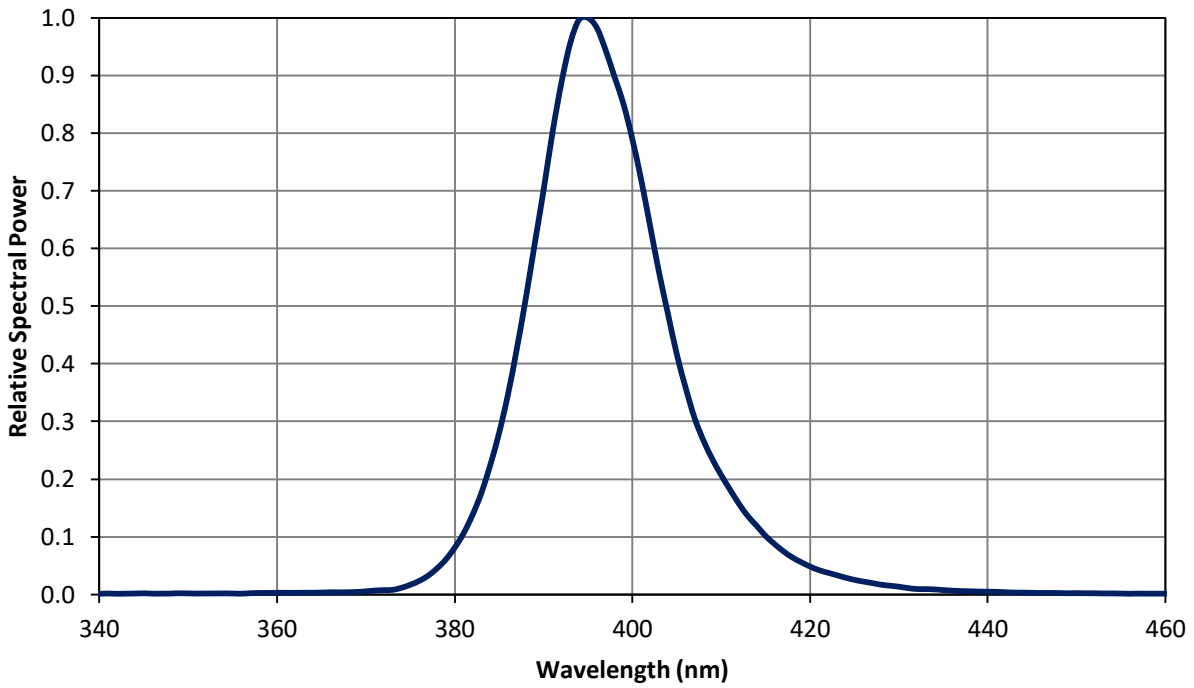

Figure 5: Typical relative spectral power vs. wavelength @ T<sub>c</sub> = 25°C.

### Typical Forward Current Characteristics

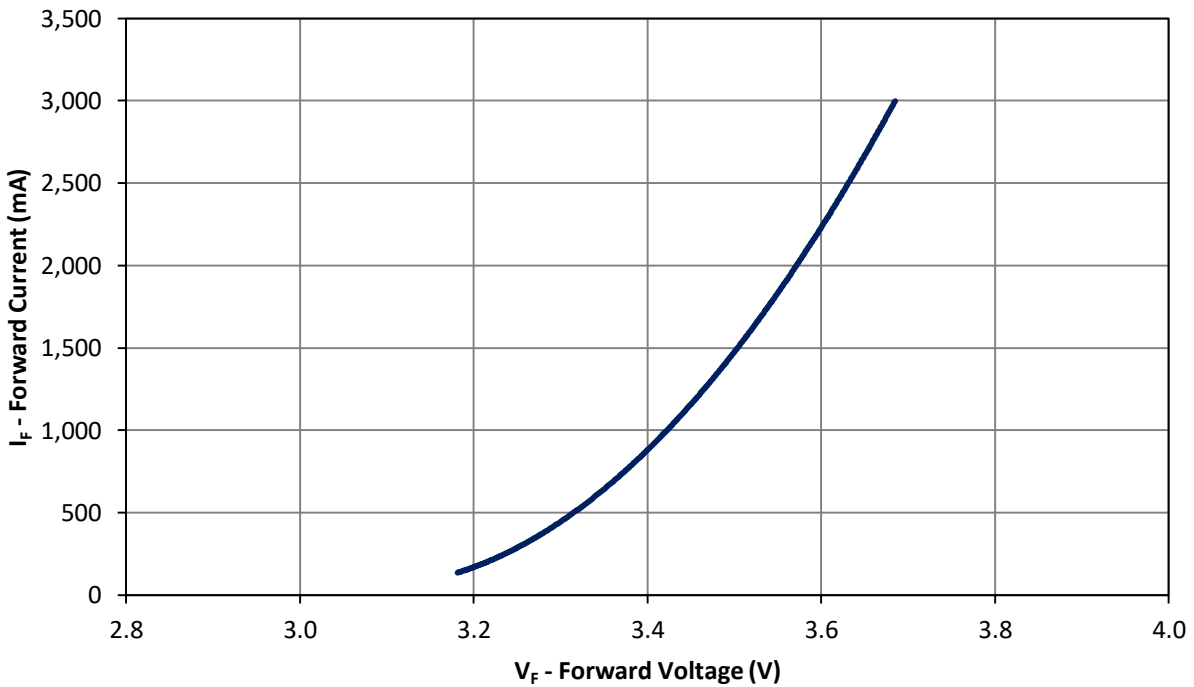

Figure 6: Typical forward current vs. forward voltage @ T<sub>c</sub> = 25°C.

### Typical Normalized Radiant Flux over Current

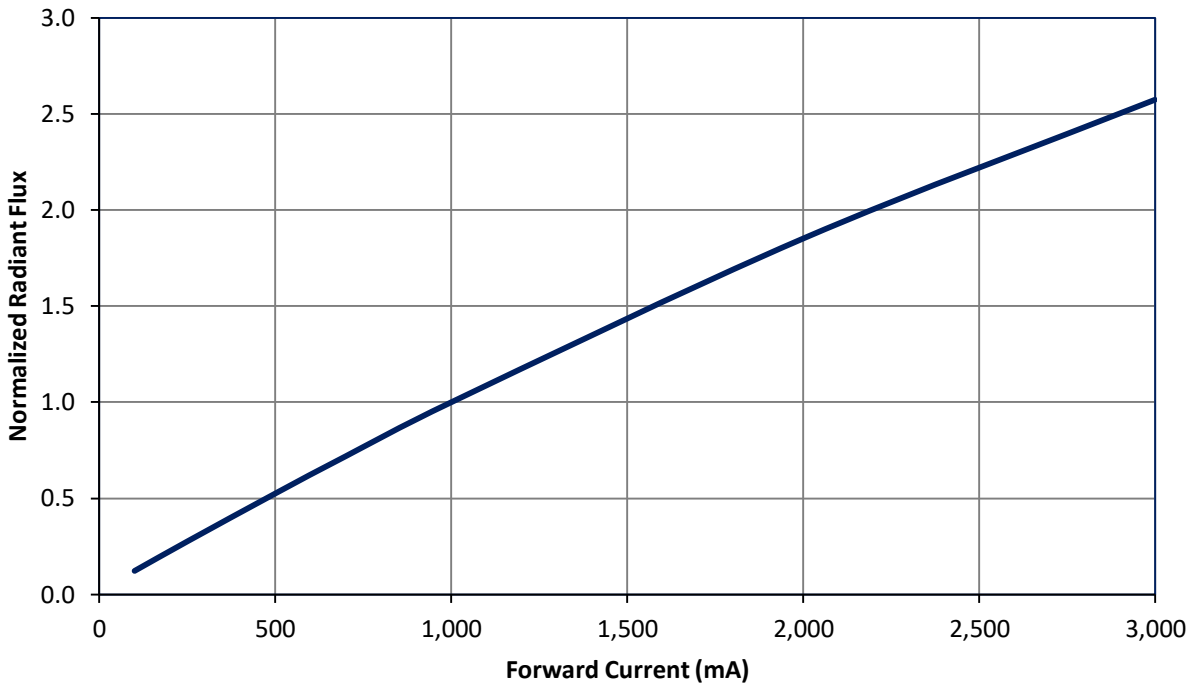

Figure 7: Typical normalized radiant flux vs. forward current @  $T_c = 25^\circ\text{C}$ .

### Typical Normalized Radiant Flux over Temperature

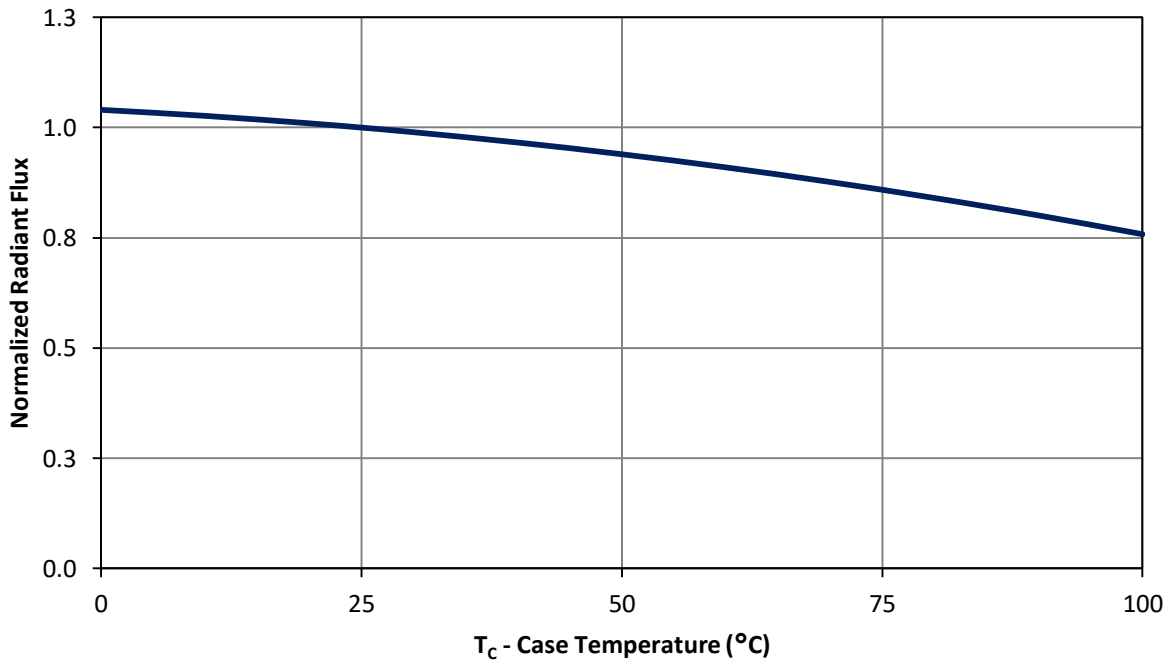

Figure 8: Typical normalized radiant flux vs. case temperature @1000mA.

### Typical Peak Wavelength Shift over Current

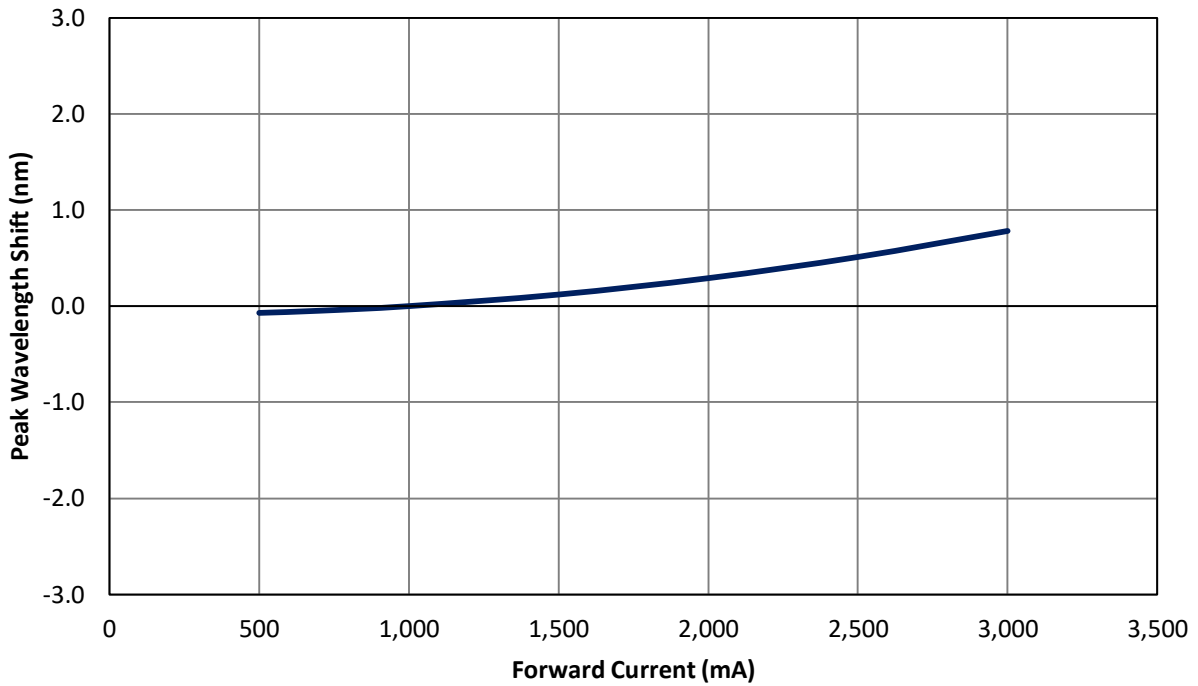

Figure 9: Typical peak wavelength shift vs. forward current @  $T_c = 25^\circ\text{C}$

### Typical Peak Wavelength Shift over Temperature

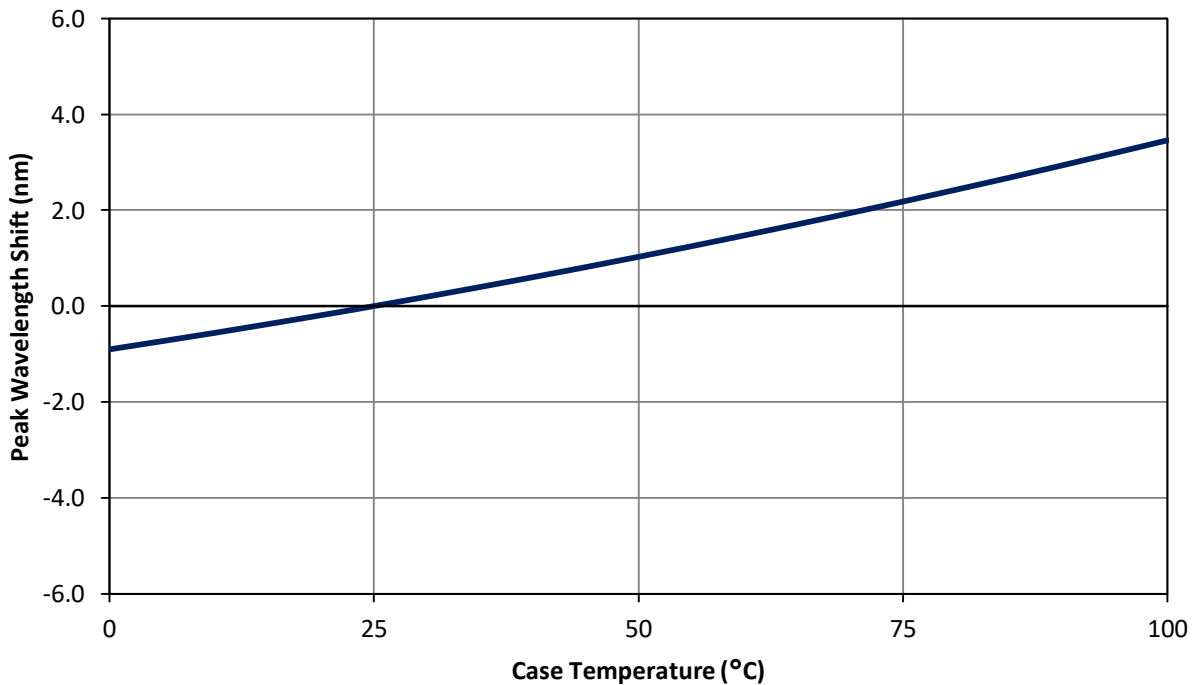

Figure 10: Typical peak wavelength shift vs. case temperature @1000mA.

## Current De-rating

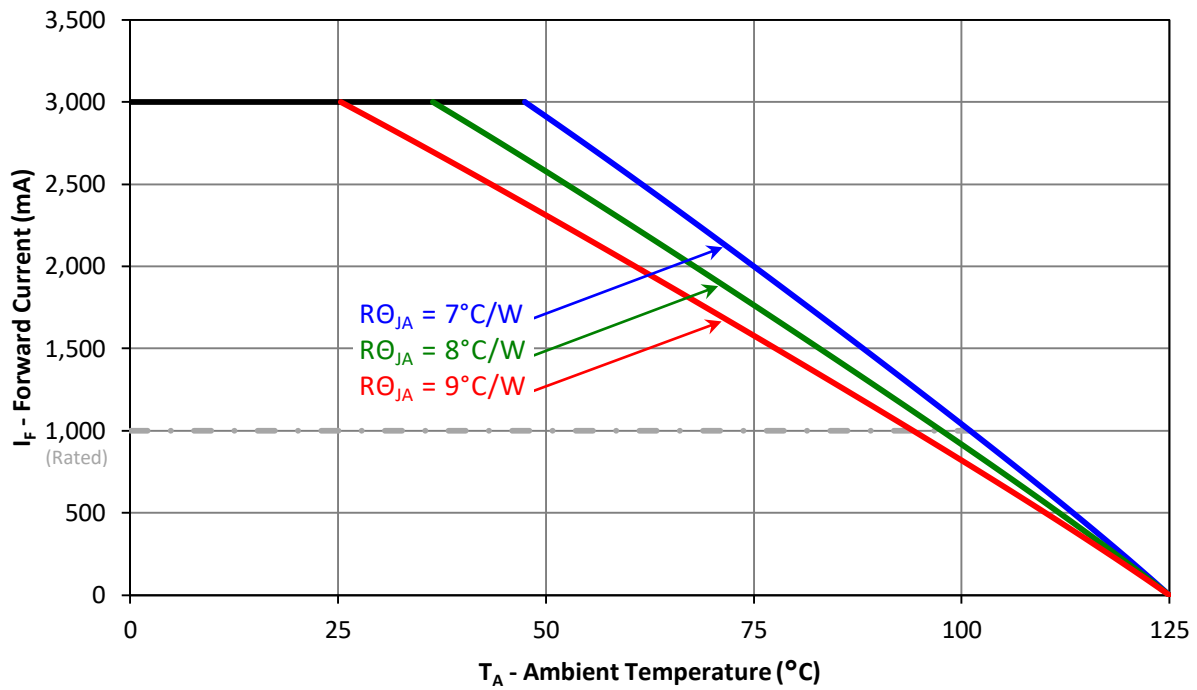

Figure 11: Maximum forward current vs. ambient temperature based on  $T_{J(\text{MAX})} = 125^\circ\text{C}$ .

Notes for Figure 11:

1.  $R\theta_{JC}$  [Junction to Case Thermal Resistance] for the LZ1-00UAP5 is typically  $2.7^\circ\text{C/W}$ .
2.  $R\theta_{JA}$  [Junction to Ambient Thermal Resistance] =  $R\theta_{JC} + R\theta_{CA}$  [Case to Ambient Thermal Resistance].

## Emitter Tape and Reel Specifications (mm)



Figure 12: Emitter carrier tape specifications (mm).

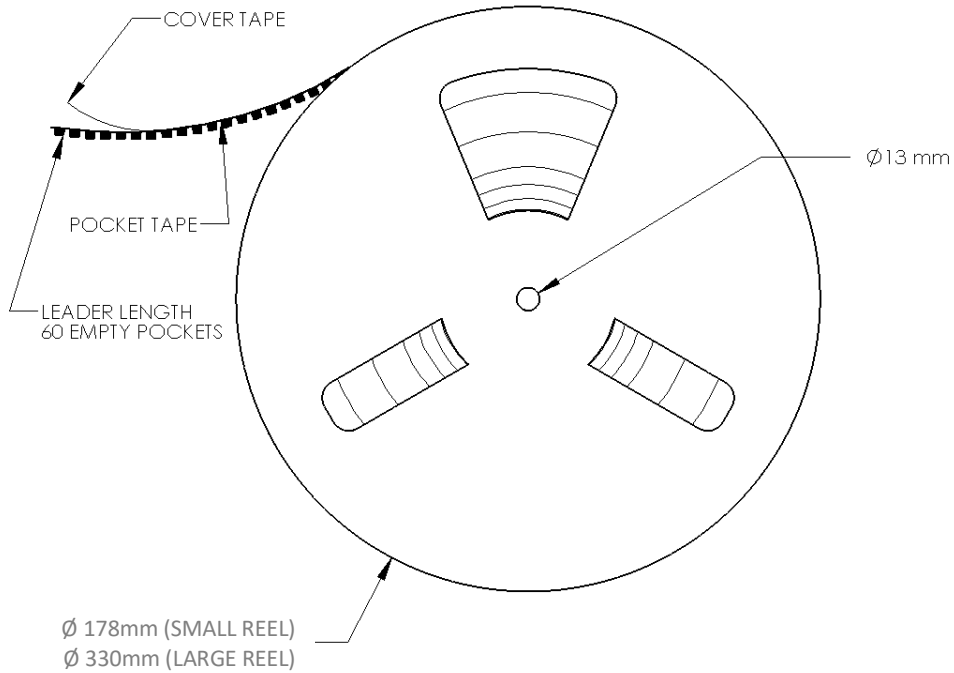

Figure 13: Emitter reel specifications (mm).

**Notes:**

1. Small reel quantity: up to 500 emitters
2. Large reel quantity: 501-2500 emitters.
3. Single flux bin and single wavelength bin per reel.

# LZ1 MCPCB Family

Part number	Type of MCPCB	Diameter (mm)	Emitter + MCPCB Thermal Resistance (°C /W)	Typical V <sub>F</sub> (V)	Typical I <sub>F</sub> (mA)
LZ1-Uxxxxx	1-channel Star	19.9	2.7 + 0.1 = 2.8	3.4	1000

## Mechanical Mounting of MCPCB

- MCPCB bending should be avoided as it will cause mechanical stress on the emitter, which could lead to substrate cracking and subsequently LED dies cracking.
- To avoid MCPCB bending:
  1. Special attention needs to be paid to the flatness of the heat sink surface and the torque on the screws.
  2. Care must be taken when securing the board to the heat sink. This can be done by tightening three M3 screws (or #4-40) in steps and not all the way through at once. Using fewer than three screws will increase the likelihood of board bending.
  3. It is recommended to always use plastics washers in combinations with the three screws.
  4. If non-taped holes are used with self-tapping screws, it is advised to back out the screws slightly after tightening (with controlled torque) and then re-tighten the screws again.

## Thermal interface material

- To properly transfer heat from LED emitter to heat sink, a thermally conductive material is required when mounting the MCPCB on to the heat sink.
- There are several varieties of such material: thermal paste, thermal pads, phase change materials and thermal epoxies. An example of such material is Electrolube EHTC.
- It is critical to verify the material's thermal resistance to be sufficient for the selected emitter and its operating conditions.
- It is recommended to verify thermal design by measuring case temperature (T<sub>c</sub>) during design phase.

## Wire soldering

- To ease soldering wire to MCPCB process, it is advised to preheat the MCPCB on a hot plate of 125-150°C. Subsequently, apply the solder and additional heat from the solder iron will initiate a good solder reflow. It is recommended to use a solder iron of more than 60W.
- It is advised to use lead-free, no-clean solder. For example: SN-96.5 AG-3.0 CU 0.5 #58/275 from Kester (pn: 24-7068-7601)

# LZ1-Uxxxxx

## 1 channel, Standard Star MCPCB (1x1) Dimensions (mm)

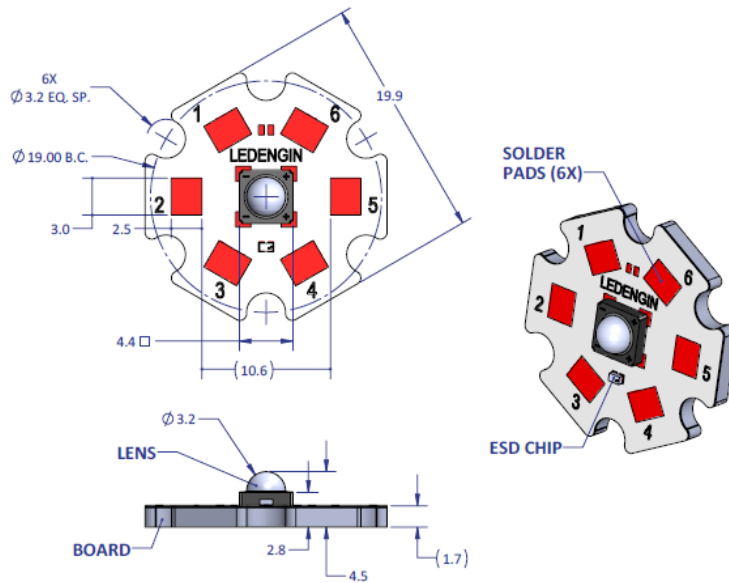

**Notes:**

- Unless otherwise noted, the tolerance =  $\pm 0.2$  mm.
- Slots in MCPCB are for M3 or #4-40 mounting screws.
- LED Engin recommends plastic washers to electrically insulate screws from solder pads and electrical traces and to evenly distribute mechanical load from screw head to MCPCB.
- LED Engin recommends using thermal interface material when attaching the MCPCB to a heat sink.
- The thermal resistance of the MCPCB is:  $R_{\theta_{c,b}} 1.5^{\circ}\text{C/W}$

## Components used

MCPCB: MHE-301 (Rayben)  
 ESD/TVS Diode: BZT52C5V1LP-7 (Diodes, Inc., for 1 LED die)  
 VBUS05L1-DD1 (Vishay Semiconductors, for 1 LED die)

Pad layout			
Ch.	MCPCB Pad	String/die	Function
1	1,2,3	1/A	Anode +
	4,5,6		Cathode -

## About LED Engin

LED Engin, an OSRAM business based in California's Silicon Valley, develops, manufactures, and sells advanced LED emitters, optics and light engines to create uncompromised lighting experiences for a wide range of entertainment, architectural, general lighting and specialty applications. LuxiGen™ multi-die emitter and secondary lens combinations reliably deliver industry-leading flux density, upwards of 5000 quality lumens to a target, in a wide spectrum of colors including whites, tunable whites, multi-color and UV LEDs in a unique patented compact ceramic package. Our LuxiTune™ series of tunable white lighting modules leverage our LuxiGen emitters and lenses to deliver quality, control, freedom and high density tunable white light solutions for a broad range of new recessed and downlighting applications. The small size, yet remarkably powerful beam output and superior in-source color mixing, allows for a previously unobtainable freedom of design wherever high-flux density, directional light is required. LED Engin is committed to providing products that conserve natural resources and reduce greenhouse emissions; and reserves the right to make changes to improve performance without notice.

For more information, please contact [LEDE-Sales@osram.com](mailto:LEDE-Sales@osram.com) or +1 408 922-7200.



Компания «Life Electronics» занимается поставками электронных компонентов импортного и отечественного производства от производителей и со складов крупных дистрибьюторов Европы, Америки и Азии.

С конца 2013 года компания активно расширяет линейку поставок компонентов по направлению коаксиальный кабель, кварцевые генераторы и конденсаторы (керамические, пленочные, электролитические), за счёт заключения дистрибьюторских договоров

Мы предлагаем:

- Конкурентоспособные цены и скидки постоянным клиентам.
- Специальные условия для постоянных клиентов.
- Подбор аналогов.
- Поставку компонентов в любых объемах, удовлетворяющих вашим потребностям.
- Приемлемые сроки поставки, возможна ускоренная поставка.
- Доставку товара в любую точку России и стран СНГ.
- Комплексную поставку.
- Работу по проектам и поставку образцов.
- Формирование склада под заказчика.
- Сертификаты соответствия на поставляемую продукцию (по желанию клиента).
- Тестирование поставляемой продукции.
- Поставку компонентов, требующих военную и космическую приемку.
- Входной контроль качества.
- Наличие сертификата ISO.

В составе нашей компании организован Конструкторский отдел, призванный помогать разработчикам, и инженерам.

Конструкторский отдел помогает осуществить:

- Регистрацию проекта у производителя компонентов.
- Техническую поддержку проекта.
- Защиту от снятия компонента с производства.
- Оценку стоимости проекта по компонентам.
- Изготовление тестовой платы монтаж и пусконаладочные работы.



Тел: +7 (812) 336 43 04 (многоканальный)

Email: [org@lifeelectronics.ru](mailto:org@lifeelectronics.ru)