

# MAX6674

# Cold-Junction-Compensated K-Thermocouple-to-Digital Converter (0°C to +128°C)

## General Description

The MAX6674 cold-junction-compensation thermocouple-to-digital converter performs cold-junction compensation and digitizes the signal from a type-K thermocouple. The data is output in a 10-bit resolution, SPI™-compatible, read-only format.

This converter resolves temperatures to 0.125°C, allows readings as high as +128°C, and exhibits thermocouple accuracy of ±2°C for temperatures ranging from 0°C to +125°C.

The MAX6674 is available in a small, 8-pin SO package.

## Applications

- Industrial
- Appliances
- HVAC

## Features

- Cold-Junction Compensation
- Simple SPI-Compatible Serial Interface
- 10 Bit, 0.125°C
- Open Thermocouple Detection

## Ordering Information

PART	TEMP RANGE	PIN-PACKAGE
MAX6674ISA	-20°C to +85°C	8 SO

## Pin Configuration

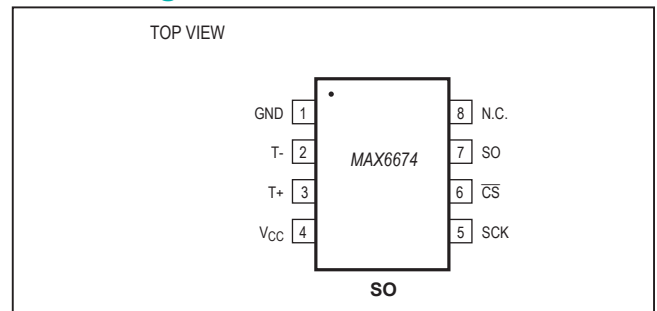

## Typical Application Circuit

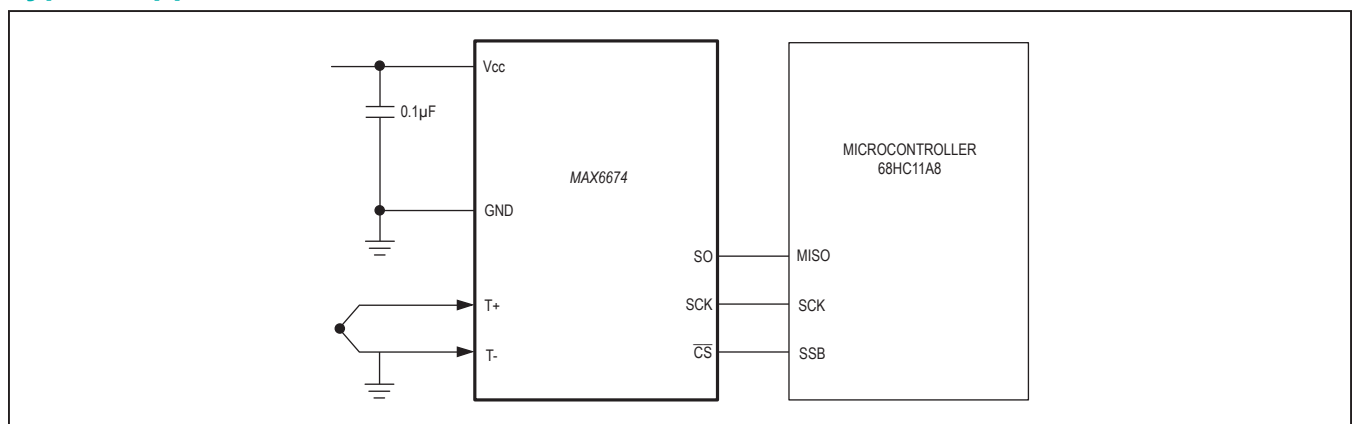

**Absolute Maximum Ratings**

Supply Voltage (V<sub>CC</sub> to GND)..... -0.3V to +6V  
 SO, SCK,  $\overline{CS}$ , T-, T+ to GND .....-0.3V to V<sub>CC</sub> + 0.3V  
 SO Current .....50mA  
 ESD Protection (Human Body Model) ..... ±2000V  
 Continuous Power Dissipation (T<sub>A</sub> = +70°C)  
 8-Pin SO (derate 5.88mW/°C above +70°C).....471mW  
 Operating Temperature Range..... -20°C to +85°C

Storage Temperature Range ..... -65°C to +150°C  
 Junction Temperature ..... +150°C  
 SO Package  
 Vapor Phase (60s) ..... +215°C  
 Infrared (15s) ..... +220°C  
 Lead Temperature (soldering, 10s) ..... +300°C

*Stresses beyond those listed under "Absolute Maximum Ratings" may cause permanent damage to the device. These are stress ratings only, and functional operation of the device at these or any other conditions beyond those indicated in the operational sections of the specifications is not implied. Exposure to absolute maximum rating conditions for extended periods may affect device reliability.*

**Electrical Characteristics**

(V<sub>CC</sub> = +3.0V to +5.5V, T<sub>A</sub> = -20°C to +85°C, unless otherwise noted. Typical values specified at +25°C.) (Note 1)

PARAMETER	SYMBOL	CONDITIONS		MIN	TYP	MAX	UNITS
Temperature Error		T <sub>THERMOCOUPLE</sub> = +100°C, T <sub>A</sub> = +25°C (Note 2)	V <sub>CC</sub> = +3.3V	-1		+1	°C
			V <sub>CC</sub> = +5V	-1.5		+1.5	
		T <sub>THERMOCOUPLE</sub> = 0°C to +125°C, T <sub>A</sub> = +25°C (Note 2)	V <sub>CC</sub> = +3.3V	-2		+2	
			V <sub>CC</sub> = +5V	-3		+3	
Temperature Conversion Constant				5.125			µV/LSB
Cold-Junction Compensation		T <sub>A</sub> = +25°C	V <sub>CC</sub> = +3.3V	-1		+1	°C
		T <sub>A</sub> = -20°C to +85°C (Note 2)	V <sub>CC</sub> = +3.3V and +5V	-3		+3	
Resolution					0.125		°C
Thermocouple Input Impedance					20		kΩ
Supply Voltage	V <sub>CC</sub>			3.0		5.5	V
Supply Current	I <sub>CC</sub>				1	2	mA
Power-On Reset Threshold		V <sub>CC</sub> rising		1	2	2.5	V
Power-On Reset Hysteresis					50		mV
Conversion Time		(Note 2)			0.15	0.18	s
<b>SERIAL INTERFACE</b>							
Input Low Voltage	V <sub>IL</sub>					0.3 x V <sub>CC</sub>	V
Input High Voltage	V <sub>IH</sub>			0.7 x V <sub>CC</sub>			V
Input Leakage Current	I <sub>LEAK</sub>	V <sub>IN</sub> = GND or V <sub>CC</sub>		-5		5	µA
Input Capacitance	C <sub>IN</sub>				5		pF

**Electrical Characteristics (continued)**

(V<sub>CC</sub> = +3.0V to +5.5V, T<sub>A</sub> = -20°C to +85°C, unless otherwise noted. Typical values specified at +25°C.) (Note 1)

PARAMETER	SYMBOL	CONDITIONS	MIN	TYP	MAX	UNITS
Output High Voltage	VOH	ISOURCE = 1.6mA	V <sub>CC</sub> - 0.4			V
Output Low Voltage	VOL	ISINK = 1.6mA			0.4	V
<b>TIMING</b>						
Serial Clock Frequency	fSCL				4.3	MHz
SCK Pulse High Width	tCH		100			ns
SCK Pulse Low Width	tCL		100			ns
CSB Fall to SCK Rise	tCSS	CL = 10pF	100			ns
CSB Fall to Output Enable	tDV	CL = 10pF			100	ns
CSB Rise to Output Disable	tTR	CL = 10pF			100	ns
SCK Fall to Output Data Valid	tDO	CL = 10pF			100	ns

**Note 1:** All specifications are 100% tested at T<sub>A</sub> = +25°C. Specification limits over temperature (T<sub>A</sub> = -20°C to +85°C) are guaranteed by design and characterization, not production tested.

**Note 2:** Guaranteed by design. Not production tested.

**Typical Operating Characteristics**

(V<sub>CC</sub> = +3.3V, T<sub>A</sub> = +25°C, unless otherwise noted.)

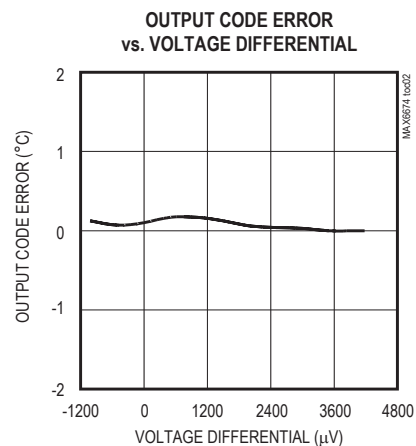
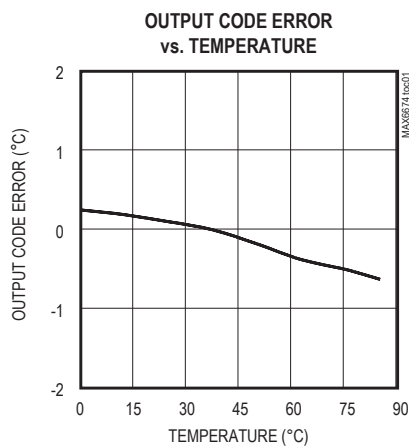

## Pin Description

PIN	NAME	FUNCTION
1	GND	Ground
2	T-	Alumel Lead of Type-K Thermocouple. Should be connected to ground externally.
3	T+	Chromel Lead of Type-K Thermocouple
4	V <sub>CC</sub>	Positive Supply. Bypass with a 0.1µF capacitor to GND.
5	SCK	Serial Clock Input
6	$\overline{\text{CS}}$	Chip Select. Set $\overline{\text{CS}}$ low to enable the serial interface.
7	S0	Serial Data Output
8	N.C.	No Connection

## Detailed Description

The MAX6674 is a sophisticated thermocouple-to-digital converter with a built-in 10-bit analog-to-digital converter (ADC). The device also contains cold-junction compensation sensing and correction, a digital controller, an SPI-compatible interface, and associated control logic.

The MAX6674 is designed to work in conjunction with an external microcontroller (µC) or other intelligence in thermostatic, process-control, or monitoring applications. The µC is typically a power-management or keyboard controller, generating SPI serial commands by “bit-banging” general-purpose input-output (GPIO) pins or through a dedicated SPI interface block.

### Temperature Conversion

The MAX6674 includes signal conditioning hardware to convert the thermocouple’s signal into a voltage that is compatible with the input channels of the ADC. The T+ and T- inputs connect to internal circuitry that reduces the introduction of noise errors from the thermocouple wires.

Before converting the thermoelectric voltages into equivalent temperature values, it is necessary to compensate for the difference between the thermocouple cold-junction side (MAX6674 ambient temperature) and a 0°C virtual reference.

For a type-K thermocouple, the voltage changes by 41µV/°C, which approximates the thermocouple characteristic with the following linear equation:

$$V_{\text{OUT}} = (41\mu\text{V}/^\circ\text{C}) 5 (T_{\text{R}} - T_{\text{AMB}})$$

where:

V<sub>OUT</sub> is the thermocouple output voltage (µV).

T<sub>R</sub> is the temperature of the remote point (°C).

T<sub>AMB</sub> is the ambient temperature (°C).

### Cold-Junction Compensation

The function of the thermocouple is to sense a difference in temperature between two ends. The thermocouple’s hot junction can be read from 0°C to +127.875°C. The cold end (ambient temperature of the board on which the MAX6674 is mounted) can only range from -20°C to +85°C. While the temperature at the cold end fluctuates, the MAX6674 continues to accurately sense the temperature difference at the opposite end.

The MAX6674 senses and corrects for the changes in the ambient temperature with cold-junction compensation. The device converts the ambient temperature reading into a voltage using a temperature-sensing diode. To make the actual thermocouple temperature measurement, the MAX6674 measures the voltage from the thermocouple’s output and from the sensing diode. The device’s internal circuitry passes the diode’s voltage (sensing ambient temperature) and thermocouple voltage (sensing remote temperature minus ambient temperature) to the conversion function stored in the ADC to calculate the thermocouple’s hot-junction temperature.

Optimal performance from the MAX6674 is achieved when the thermocouple cold junction and the device are at the same temperature. Avoid placing heat-generating devices or components near the MAX6674 because this may produce cold-junction-related errors.

### Digitization

The ADC adds the cold-junction diode measurement with the amplified thermocouple voltage and reads out the 10-bit sequence onto the S0 pin. A sequence of all zeros means the thermocouple reading is 0°C. A sequence of all ones means the thermocouple reading is +127.875°C.

## Applications Information

### Serial Interface

The *Typical Application Circuit* shows the MAX6674 interfaced with a microcontroller. In this example, the MAX6674 processes the reading from the thermocouple and transmits the data through a serial interface. Force  $\overline{CS}$  low and apply a clock signal at SCK to read the results at S0. Forcing  $\overline{CS}$  low immediately stops any conversion process. Initiate a new conversion process by forcing  $\overline{CS}$  high.

Force  $\overline{CS}$  low to output the first bit on the S0 pin. A complete serial interface read requires 16 clock cycles. Read the 16 output bits on the falling edge of the clock. The first bit, D15, is a dummy sign bit and always zero. Bits D14–D5 contain the converted temperature in the order of MSB to LSB. Bit D4 reads a high value when any of the thermocouple inputs are open. Bit D3 is always low to provide a device ID for the MAX6674. Bits D2–D0 are in three-state when  $\overline{CS}$  is high.

Figure 1a is the serial interface protocol and Figure 1b shows the serial interface timing. Figure 2 is the S0 output.

### Open Thermocouple

Bit D4 is normally low and goes high if the thermocouple input is open. The open thermocouple detection circuit is implemented completely into the MAX6674. In order to allow the operation of the open thermocouple detector, T- must be grounded. Make the ground connection as close to the GND pin as possible.

### Noise Considerations

The accuracy of the MAX6674 is susceptible to power-supply coupled noise. The effects of power-supply noise can be minimized by placing a 0.1 $\mu$ F ceramic bypass capacitor close to the supply pin of the device.

### Thermal Considerations

Self-heating degrades the temperature measurement accuracy of the MAX6674 in some applications. The magnitude of the temperature errors depends on the thermal conductivity of the MAX6674 package, the mounting technique, and the effects of airflow. Use a large ground plane to improve the temperature measurement accuracy.

The accuracy of a thermocouple system can also be improved by following these precautions:

- Use the largest wire possible that does not shunt heat away from the measurement area.
- If small wire is required, use it only in the region of the measurement and use extension wire for the region with no temperature gradient.
- Avoid mechanical stress and vibration that could strain the wires.
- When using long thermocouple wires, use a twisted-pair extension wire.
- Avoid steep temperature gradients.
- Try to use the thermocouple wire well within its temperature rating.
- Use the proper sheathing material in hostile environments to protect the thermocouple wire.
- Use extension wire only at low temperatures and only in regions of small gradients.
- Keep an event log and a continuous record of thermocouple resistance.

### Reducing Effects of Pick-Up Noise

The input amplifier (A1) is a low-noise amplifier designed to enable high-precision input sensing. Keep the thermocouple and connecting wires away from electrical noise sources.



Block Diagram

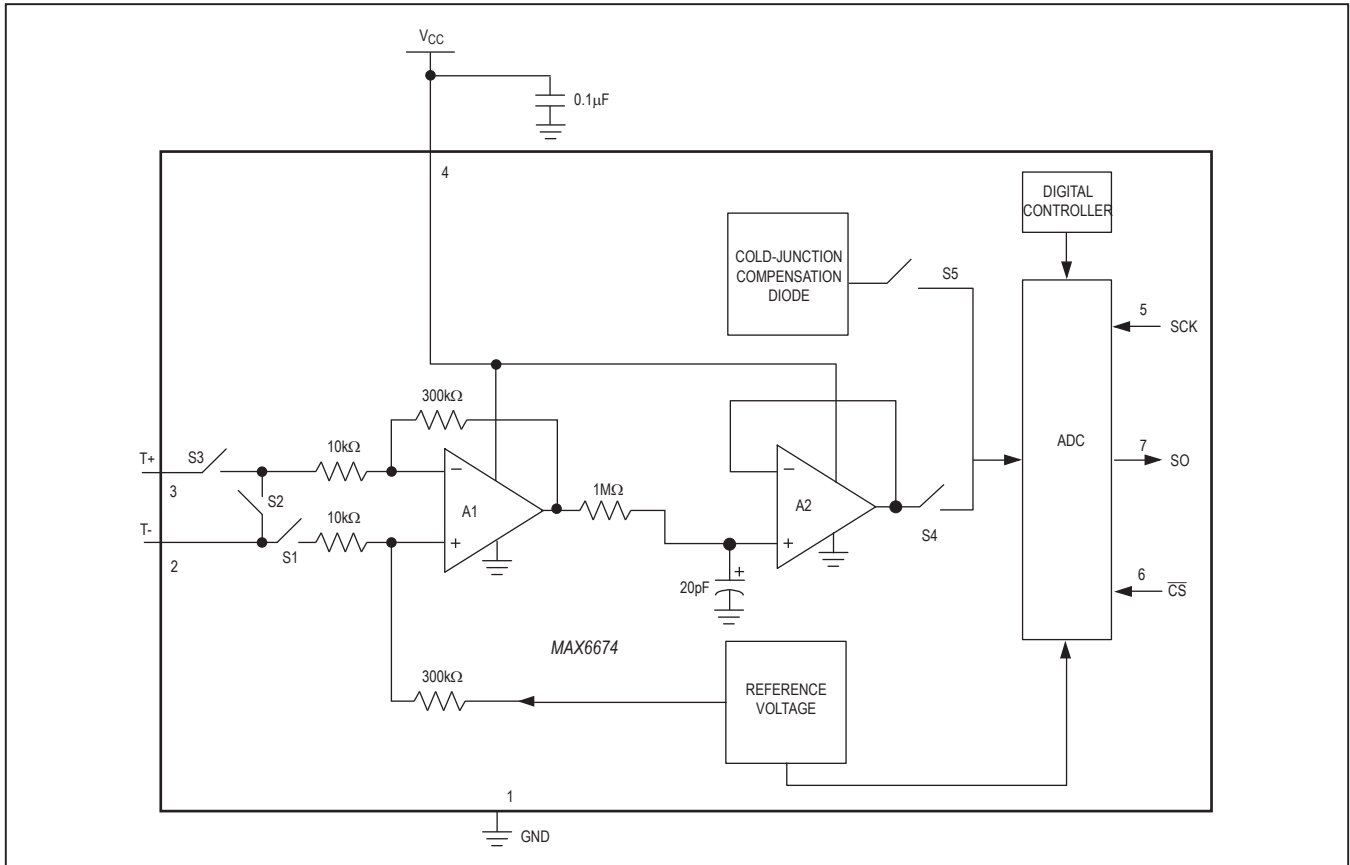

Chip Information

TRANSISTOR COUNT: 6460  
 PROCESS: BICMOS

Package Information

For the latest package outline information and land patterns (footprints), go to [www.maximintegrated.com/packages](http://www.maximintegrated.com/packages). Note that a "+", "#", or "-" in the package code indicates RoHS status only. Package drawings may show a different suffix character, but the drawing pertains to the package regardless of RoHS status.

PACKAGE TYPE	PACKAGE CODE	OUTLINE NO.	LAND PATTERN NO.
8 SO	S8-2	<a href="#">21-0041</a>	<a href="#">90-0096</a>

MAX6674

Cold-Junction-Compensated K-Thermocouple-to-Digital Converter (0°C to +128°C)

Revision History

REVISION NUMBER	REVISION DATE	DESCRIPTION	PAGES CHANGED
2	4/14	No IV OPNs; removed Automotive reference from <i>Applications</i> section	1

For pricing, delivery, and ordering information, please contact Maxim Direct at 1-888-629-4642, or visit Maxim Integrated's website at [www.maximintegrated.com](http://www.maximintegrated.com).

*Maxim Integrated cannot assume responsibility for use of any circuitry other than circuitry entirely embodied in a Maxim Integrated product. No circuit patent licenses are implied. Maxim Integrated reserves the right to change the circuitry and specifications without notice at any time. The parametric values (min and max limits) shown in the Electrical Characteristics table are guaranteed. Other parametric values quoted in this data sheet are provided for guidance.*



Компания «Life Electronics» занимается поставками электронных компонентов импортного и отечественного производства от производителей и со складов крупных дистрибьюторов Европы, Америки и Азии.

С конца 2013 года компания активно расширяет линейку поставок компонентов по направлению коаксиальный кабель, кварцевые генераторы и конденсаторы (керамические, пленочные, электролитические), за счёт заключения дистрибьюторских договоров

Мы предлагаем:

- Конкурентоспособные цены и скидки постоянным клиентам.
- Специальные условия для постоянных клиентов.
- Подбор аналогов.
- Поставку компонентов в любых объемах, удовлетворяющих вашим потребностям.
- Приемлемые сроки поставки, возможна ускоренная поставка.
- Доставку товара в любую точку России и стран СНГ.
- Комплексную поставку.
- Работу по проектам и поставку образцов.
- Формирование склада под заказчика.
- Сертификаты соответствия на поставляемую продукцию (по желанию клиента).
- Тестирование поставляемой продукции.
- Поставку компонентов, требующих военную и космическую приемку.
- Входной контроль качества.
- Наличие сертификата ISO.

В составе нашей компании организован Конструкторский отдел, призванный помогать разработчикам, и инженерам.

Конструкторский отдел помогает осуществить:

- Регистрацию проекта у производителя компонентов.
- Техническую поддержку проекта.
- Защиту от снятия компонента с производства.
- Оценку стоимости проекта по компонентам.
- Изготовление тестовой платы монтаж и пусконаладочные работы.



Тел: +7 (812) 336 43 04 (многоканальный)

Email: [org@lifeelectronics.ru](mailto:org@lifeelectronics.ru)