

NOTES:

- 1. PART NUMBER VARIABLES: (SEE SHEET 2 FOR ADDITIONAL INFORMATION)
NOT ALL POSSIBLE CONFIGURATIONS SHOWN ON THIS DRAWING ARE AVAILABLE AS STANDARD PRODUCTS. PLEASE CHECK WITH TE CONNECTIVITY TO CONFIRM AVAILABILITY.
- MTC100-BXX-PXX-XXX MODIFICATION NUMBER. REFER TO APPLICABLE MOD DESCRIPTION SHEET. "BLANK WHEN NOT APPLICABLE"
- 1=LONG TAIL
2=SHORT TAIL
3=90° IN "B" DIRECTION
- 2=NICKEL PLATE
3=CADMIUM OVER NICKEL PLATE
- 1=1 INCH
2=2 INCH
- F=FLANGED WITH STANDARD PANEL GASKET
S=FLANGED/SHIELDED WITH EME PANEL GASKET
J=FLANGELESS
Y=SPECIALS: REFER TO INDIVIDUAL SPECIFICATION CONTROL DRAWINGS FOR DESCRIPTIONS
- 2. A BOX MOUNT RECEPTACLE MATES WITH A MTC PLUG CONTAINING SOCKET INSERTS. REFER TO APPLICABLE TE CONNECTIVITY SPECIFICATION CONTROL DRAWING FOR DETAILS.
- 3. FOR KEYING INFORMATION, SEE TE CONNECTIVITY DRAWING D-659-0080.
- 4. THESE ITEMS ARE SUPPLIED UNASSEMBLED.
- 5. DIMENSION SHOWN IS WITH MATED PLUG CONNECTOR: a. WITH CABLE CLAMP
b. WITHOUT CABLE CLAMP AND WITHOUT EARS
- 6. THIS BOX MOUNT RECEPTACLE IS REAR PANEL MOUNTED BY REMOVING AS MANY PANEL WASHERS AS REQUIRED TO ACCOMMODATE THE THICKNESS OF THE PANEL BEING USED. SEE SHEET 2, TABLE 2, AND SHEET 3, FIGURE 2.
- 7. FOR FRONT PANEL MOUNTING OF A FLANGELESS CONNECTOR, USE HARDWARE KIT CHA-0038-00 AND REFER TO THAT SPECIFICATION CONTROL DRAWING FOR APPLICATION DETAILS.
- 8. WIRE WRAPPABLE POST DESIGNED BY STANDARD WIRE WRAP SPECIFICATION.
- 9. WHEN MOUNTING FLANGELESS CONNECTORS ADJACENT TO ONE ANOTHER AND USING THE .400 MINIMUM CENTERLINE LOCATION, THERE WILL BE NO WEB BETWEEN PANEL CUT-OUTS. SEE SHEET 3, FIGURE 2 FOR DETAILS.
- 10. KIT NUMBER CHA-0046 IS AVAILABLE FOR MOUNTING A CONNECTOR TO A PRINTED CIRCUIT BOARD. SEE SHEET 3, FIGURE 3 FOR HOLE PATTERN RECOMMENDATION.
- 11. SEE SHEET 3, TABLE 3, FOR WEIGHTS. WEIGHTS SHOWN ARE WITHOUT DUST CAP AND WITHOUT POST PROTECTOR.
- 12. DUST CAP SUPPLIED WITH ASSEMBLY.
- 13. TORQUE MOUNTING HARDWARE TO: 14-16 IN.-LBS.
- 14. THE FLANGE THICKNESS IS DIFFERENT ACCORDING TO SHELL STYLE AND SIZE.
THE THICKNESS: 0.170 [4.32] FOR P/N MTC100-BF2-PXX AND MTC100-BS2-PXX.
THE THICKNESS: 0.160 [4.06] FOR P/N MTC100-BX1-PXX AND MTC100-BJ2-PXX.

REVISIONS			
LTR	DESCRIPTION	DATE	APPROVED
J1	REVISED PER ECO-11-005139	29MAR11	RK/HMR

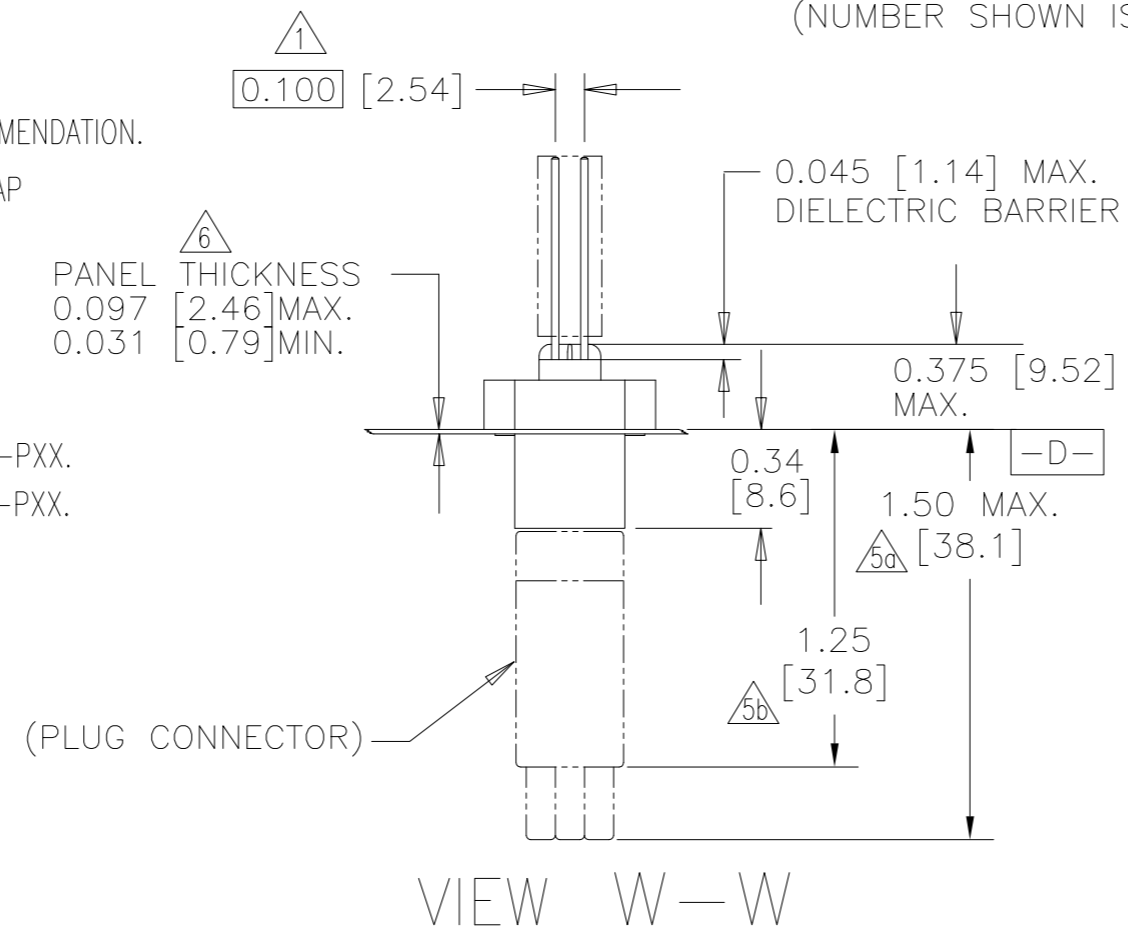
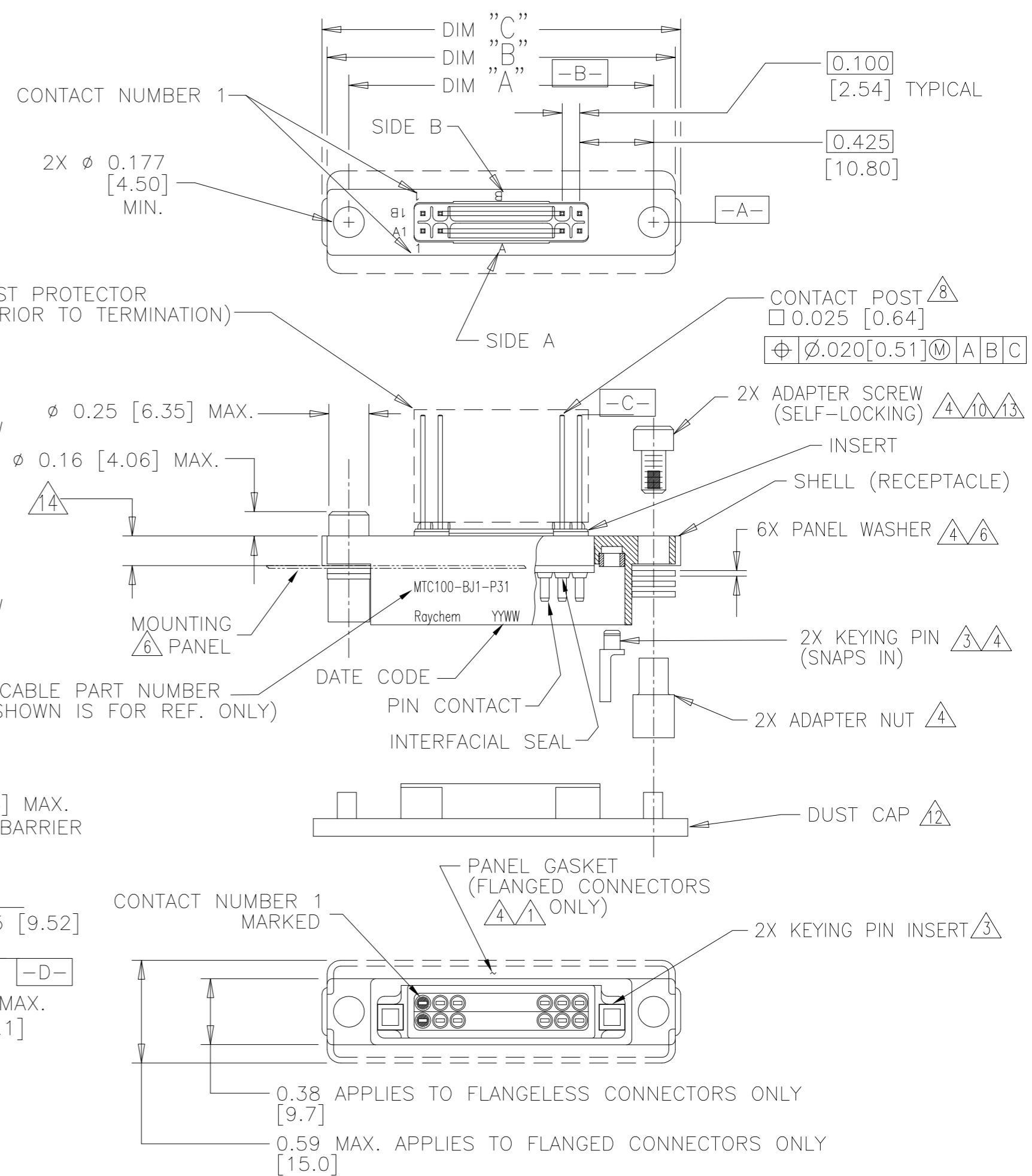

CUSTOMER DRAWING

IF THIS DOCUMENT IS PRINTED IT BECOMES UNCONTROLLED. CHECK FOR THE LATEST REVISION.

UNLESS OTHERWISE SPECIFIED DIMENSIONS ARE IN INCHES. METRIC DIMENSIONS ARE IN BRACKETS. DECIMALS .XXX ± .005 {0.13mm} .XX ± .01 {0.25mm} ANGLES .X ± WEIGHT	RE-DRAWN	J.VALENTA	04/20/99	TE Connectivity	Raychem Interconnect 300 Constitution Drive Menlo Park, CA 94025 U.S.A			
	CHECKED							
	APPROVED	M.HIGGY	04/23/99	TITLE	CONNECTOR, RECEPTACLE, BOX MOUNT, .025 SQ., TERMINATION POST, MTC100 SERIES			
	CAD NAME	MTC100-BXX-PXX-XXX		SIZE	C			
THIRD ANGLE PROJECTION			CAGE CODE:	06090	DWG. NO.	MTC100-BXX-PXX-XXX	REV	J1
			SCALE:	NONE	SHEET 1 OF 3			

DWG NO. MTC100-BXX-PXX-XXX SHEET 1

4

3

2

1

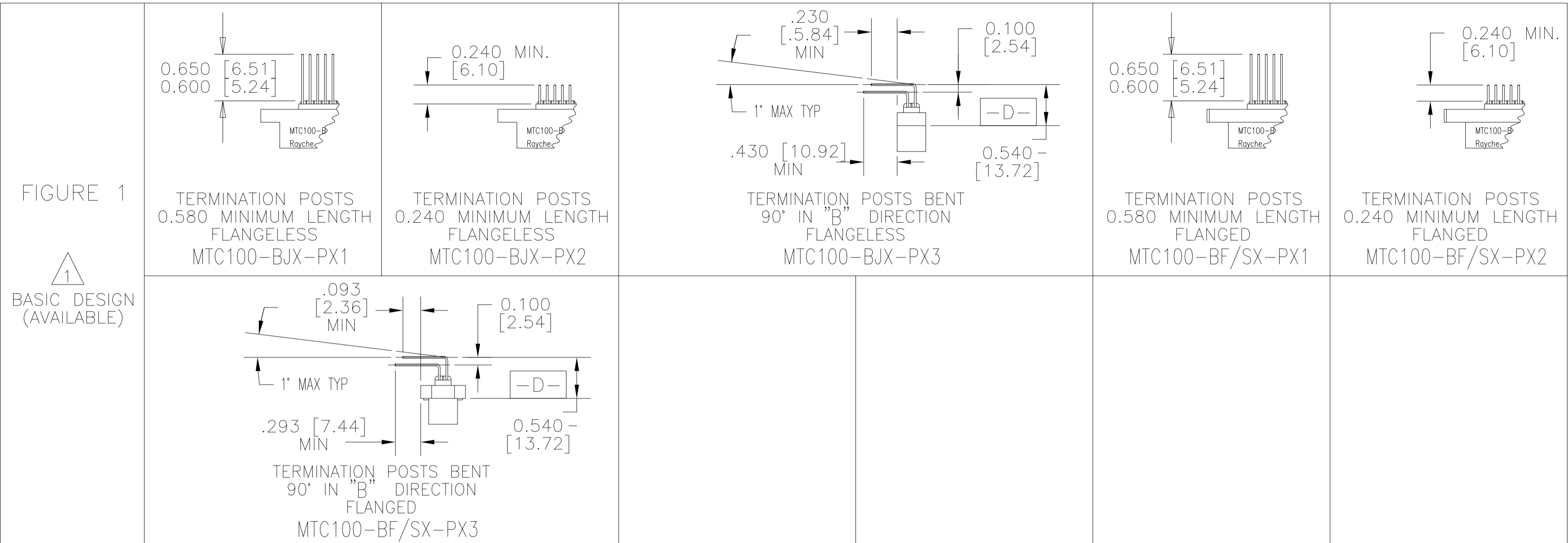

TABLE 1

CONNECTOR SIZE	"A"	"B"	"C"	"X"	"Y"	"Z" (MIN)
1 INCH	FLANGELESS 1.750 [44.45]	2.00 [50.8]	X	1.750 [44.45]	1.520 [38.61]	0.400 [10.16]
	FLANGED 1.750 [44.45]	X	2.06 [52.3]	1.750 [44.45]	1.520 [38.61]	0.600 [15.24]
2 INCH	FLANGELESS 2.750 [69.85]	3.00 [76.2]	X	2.750 [69.85]	2.520 [64.00]	0.400 [10.16]
	FLANGED 2.750 [69.85]	X	3.06 [77.7]	2.750 [69.85]	2.520 [64.00]	0.600 [15.24]

TABLE 2

PANEL THICKNESS	NUMBER OF PANEL WASHERS FOR EACH FASTENER
0.031/0.036 [0.8]/[0.9]	2
0.062/0.067 [1.5]/[1.7]	1
0.93/0.097 [2.3]/[2.4]	0

IF THIS DOCUMENT IS PRINTED IT BECOMES UNCONTROLLED.
CHECK FOR THE LATEST REVISION.

CUSTOMER DRAWING

SIZE C	CAGE CODE: 06090	DWG. NO. MTC100-BXX-PXX-XXX	REV. J1
CAD NAME: MTC100-BXX-PXX-XXX		SCALE: NONE	SHEET 2 OF 3

4

3

2

1

SHEET

DWG. NO. MTC100-BXX-PXX-XXX

2

A

D

C

B

A

SPECIFICATIONS:

MATERIALS:

- A. SHELL ALUMINUM ALLOY PER ASTM B85 / B85M
- B. ADAPTER SCREW STAINLESS STEEL PER SAE-AMS-QQ-S-763, 300 SERIES
- C. ADAPTER NUT STAINLESS STEEL PER SAE-AMS-QQ-S-763, 300 SERIES
- D. STANDARD PANEL GASKET SILICONE ELASTOMER PER MIL-STD-25988
EMI PANEL GASKET CONDUCTIVE ELASTOMER PER MIL-DTL-83528 TYPE C, GRAY.
- E. INSERT HIGH GRADE POLARYLENE THERMOPLASTIC, MOLDED
- F. INTERFACIAL SEAL FLUOROSILICONE PER MIL-DTL-25988
- G. KEYING PIN HIGH GRADE POLARYLENE THERMOPLASTIC, MOLDED
- H. PIN CONTACT COPPER ALLOY PER ASTM B139 / B139M
- I. PANEL WASHER STAINLESS STEEL PER SAE-AMS-QQ-S-763 OR ASTM B240, 300 SERIES
- J. KEYING PIN INSERT HIGH GRADE POLARYLENE THERMOPLASTIC, MOLDED

FINISH:

	APPLIES TO NICKEL PLATED CONNECTORS (STANDARD PLATING)	APPLIES TO CADMIUM PLATED CONNECTORS
A. SHELL	NICKEL PLATED PER SAE-AMS-C-26074 CLASS 3, GRADE B	CADMIUM PLATED PER SAE-AMS-QQ-P-416 OVER NICKEL UNDERPLATE
B. ADAPTER SCREW	PASSIVATED PER SAE-AMS-QQ-P-35	CADMIUM PLATED PER SAE-AMS-QQ-P-416
C. ADAPTER NUT	PASSIVATED PER SAE-AMS-QQ-P-35	CADMIUM PLATED PER SAE-AMS-QQ-P-416
D. PANEL WASHER	PASSIVATED PER SAE-AMS-QQ-P-35	CADMIUM PLATED PER SAE-AMS-QQ-P-416
E. PIN CONTACT	GOLD PLATED PER ASTM B488 TYPE 2, GRADE C	

DESIGN AND CONSTRUCTION:

THE CONNECTORS SPECIFIED HEREIN ARE PANEL MOUNTED RECEPTACLES WITH FIXED (NON-REMOVABLE) PIN INSERTS AND CONTACTS. THE CONNECTOR IS WITHOUT PROVISIONS FOR CABLE CLAMPS OR TERMINATION SEALS.

PERFORMANCE:

THESE CONNECTORS MEET THE APPLICABLE REQUIREMENTS OF TE CONNECTIVITY SPECIFICATION C-6111.

PERFORMANCE; SHELL BE IN ACCORDANCE WITH C-6111, EXCEPT AS FOLLOWS

HUMIDITY	} THE CONNECTOR TERMINATION END MUST BE SUITABLY PROTECTED FOR TESTING OR APPLICATION IN ANY OF THESE ENVIRONMENTS.
ALTITUDE IMMERSION	
ALTITUDE - LOW TEMPERATURE	
FLUID IMMERSION	

TABLE 3

PART NUMBER	WEIGHT MAXIMUM GRAMS
MTC100-BF1-P32	23.0
MTC100-BF2-P32	33.2

THE FOLLOWING TABLE CONSISTS OF WEIGHTS FOR THESE SPECIFIC PART NUMBERS



IF THIS DOCUMENT IS PRINTED IT BECOMES UNCONTROLLED. CHECK FOR THE LATEST REVISION.

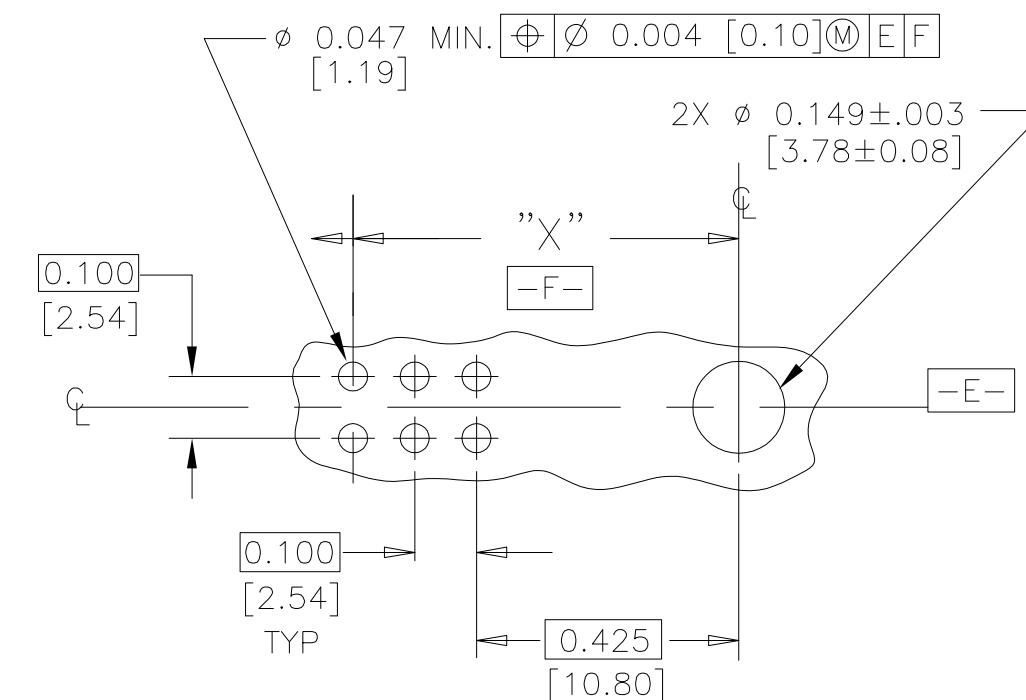

RECOMMENDED HOLE PATTERN AND SIZE FOR PRINTED CIRCUIT BOARDS

FIGURE 3

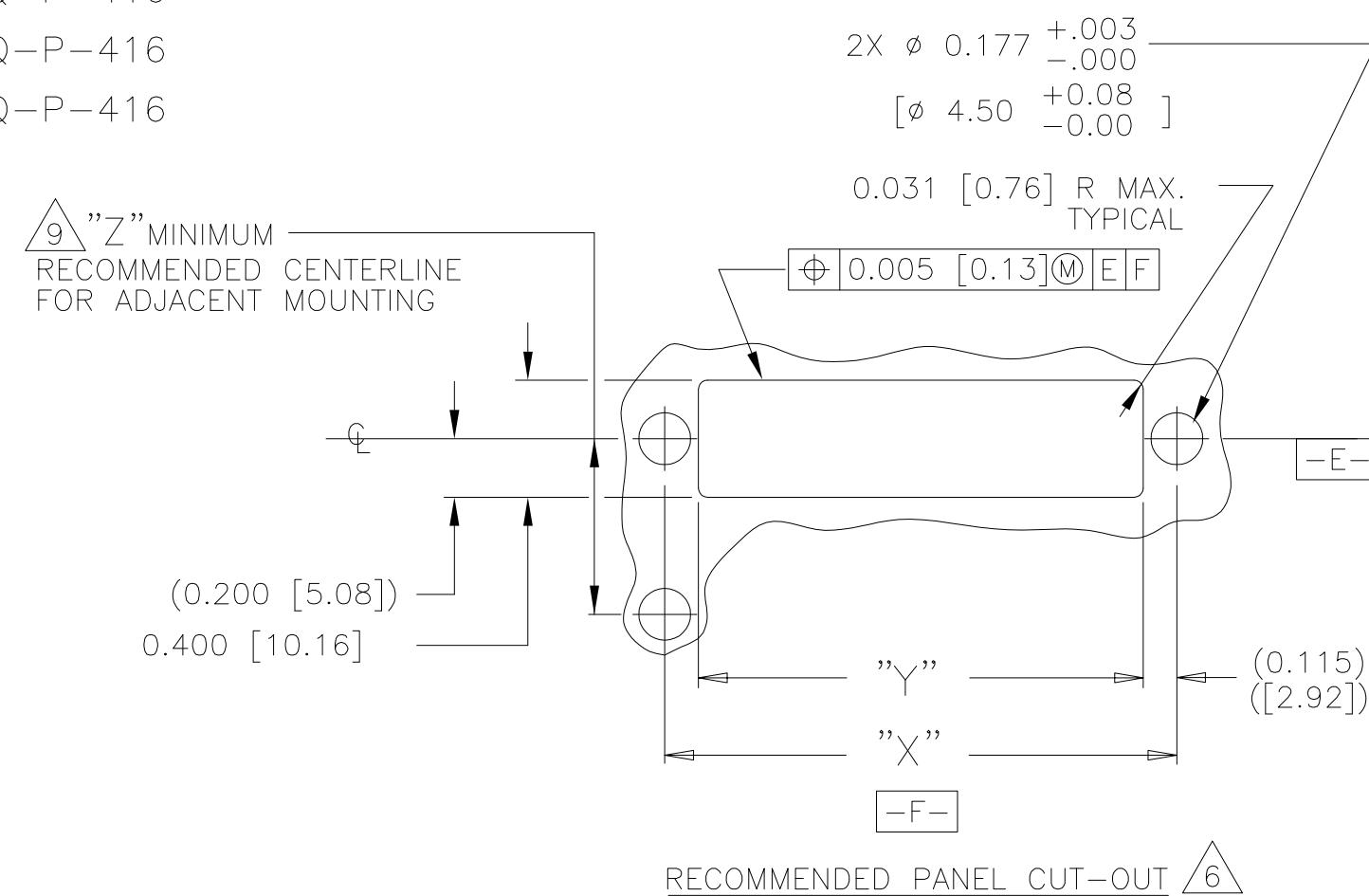

RECOMMENDED PANEL CUT-OUT

FIGURE 2

CUSTOMER DRAWING

SIZE C	CAGE CODE: 06090	DWG. NO. MTC100-BXX-PXX-XXX	REV J1
CAD NAME MTC100-BXX-PXX-XXX		SCALE: NONE	SHEET 3 OF 3

Компания «Life Electronics» занимается поставками электронных компонентов импортного и отечественного производства от производителей и со складов крупных дистрибьюторов Европы, Америки и Азии.

С конца 2013 года компания активно расширяет линейку поставок компонентов по направлению коаксиальный кабель, кварцевые генераторы и конденсаторы (керамические, пленочные, электролитические), за счёт заключения дистрибьюторских договоров

Мы предлагаем:

- Конкурентоспособные цены и скидки постоянным клиентам.
- Специальные условия для постоянных клиентов.
- Подбор аналогов.
- Поставку компонентов в любых объемах, удовлетворяющих вашим потребностям.
- Приемлемые сроки поставки, возможна ускоренная поставка.
- Доставку товара в любую точку России и стран СНГ.
- Комплексную поставку.
- Работу по проектам и поставку образцов.
- Формирование склада под заказчика.
- Сертификаты соответствия на поставляемую продукцию (по желанию клиента).
- Тестирование поставляемой продукции.
- Поставку компонентов, требующих военную и космическую приемку.
- Входной контроль качества.
- Наличие сертификата ISO.

В составе нашей компании организован Конструкторский отдел, призванный помогать разработчикам, и инженерам.

Конструкторский отдел помогает осуществить:

- Регистрацию проекта у производителя компонентов.
- Техническую поддержку проекта.
- Защиту от снятия компонента с производства.
- Оценку стоимости проекта по компонентам.
- Изготовление тестовой платы монтаж и пусконаладочные работы.



Тел: +7 (812) 336 43 04 (многоканальный)
Email: org@lifeelectronics.ru