

### Features

- $V_{IN}$  Range: 2.7V to 5.5V
- Fully Programmable Current with Single Wire
  - 32-Step Logarithmic Scale
  - 20/25mA Max Current per Channel
  - Four Low Current Settings Down to 50 $\mu$ A
  - Low  $I_Q$  (50 $\mu$ A) for Low Current Mode
- Tri-Mode 1X, 1.5X, and 2X Charge Pump for Maximum Efficiency and  $V_F$  Coverage
- Drives up to Six Channels of LEDs
- Individual Main/Sub-Group Control
- No Inductors, Low Noise Operation
- 0.5/1/2MHz Constant Switching Frequency
- Small Application Circuit
- Built-In Thermal Protection
- Built-In Auto-Disable For Open Circuit
- Automatic Soft Start
- $I_Q < 1\mu$ A in Shutdown
- Thermally-Enhanced QFN4040-16 Package: Available in "Green" Molding Compound (No Br, Sb)
- Lead Free Finish / RoHS Compliant (Note 1)

### General Description

The AP3156 is a low noise, constant frequency charge pump DC/DC converter that uses a tri-mode load switch (1X), fractional (1.5X), and doubling (2X) conversion to maximize efficiency for white LED applications. The AP3156 is capable of driving the LED channels at 120mA maximum from a 2.7V to 5.5V input. The current sinks may be operated individually or in parallel for driving higher-current LEDs. A low external parts count (two 1 $\mu$ F flying capacitors and two small 1 $\mu$ F capacitors at  $V_{IN}$  and  $V_{OUT}$ ) make this part ideally suited for small, battery-powered applications.

AP3156 serial digital input is used to enable, disable and set current for each LED with a 32-level logarithmic scale plus four low-current settings down to 50 $\mu$ A for optimized efficiency, with a low quiescent current of only 50 $\mu$ A.

Each output of the AP3156 is equipped with built-in protection for  $V_{OUT}$  short circuit and auto-disable for LED failure conditions. Built-in soft-start circuitry prevents excessive inrush current during start-up. A low-current shutdown feature disconnects the load from  $V_{IN}$  and reduces quiescent current to less than 1 $\mu$ A.

The AP3156 is available in a lead-free, space-saving, thermally enhanced 16-pin 4x4mm QFN package.

### Applications

- Color (RGB) Lighting
- Programmable Current Sinks
- White LED Backlighting
- White Photo Flash for Digital Still Cameras

### Typical Application Circuit

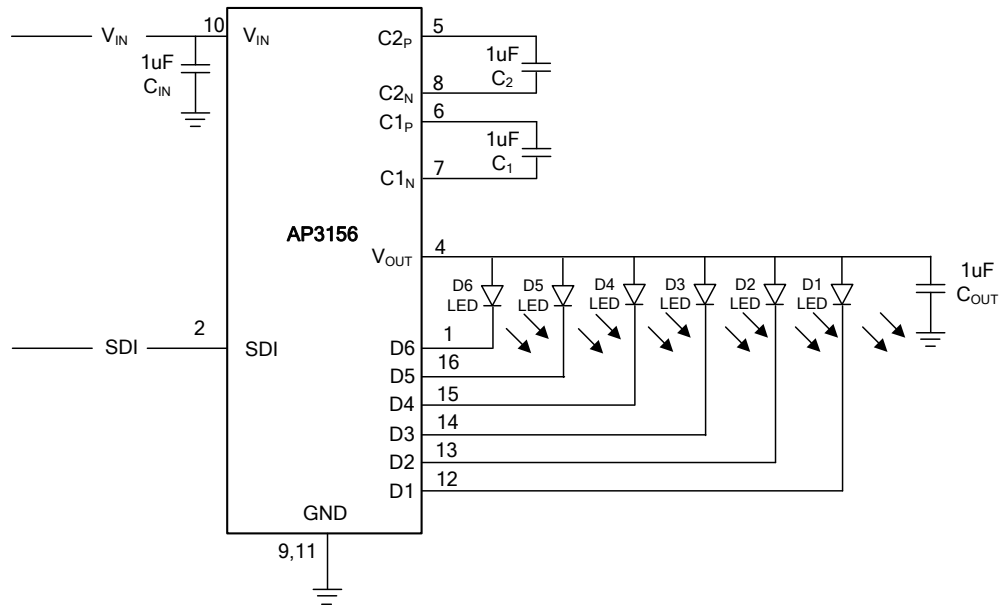

### Ordering Information

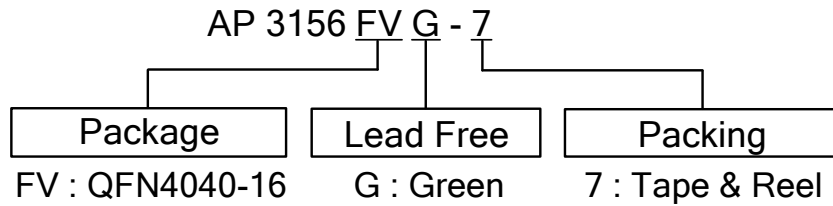

Device	Package Code	Packaging (Note 2)	7" Tape and Reel	
			Quantity	Part Number Suffix
AP3156FVG-7	FV	QFN4040-16	1500/Tape & Reel	-7

- Notes:
1. EU Directive 2002/95/EC (RoHS). All applicable RoHS exemptions applied. Please visit our website at [http://www.diodes.com/products/lead\\_free.html](http://www.diodes.com/products/lead_free.html)
  2. Pad layout as shown on Diodes Inc. suggested pad layout document AP02001, which can be found on our website at <http://www.diodes.com/datasheets/ap02001.pdf>.

### Pin Assignments

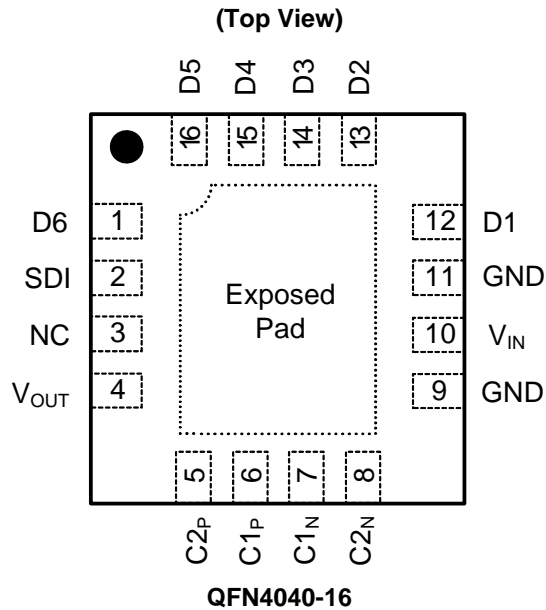

### Pin Descriptions

Pin Name	Pin Number	Description
D6	1	Current Sink Input #6. Connected to VOUT when un-used.
SDI	2	Serial Digital Interface Control Pin
NC	3	No Connection
VOUT	4	Charge pump output to drive load circuit. Requires 1 $\mu$ F capacitor connected between this pin and ground
C2P	5	Positive Terminal of Flying Capacitor 2. Connects a 1 $\mu$ F capacitor between C2P and C2N.
C1P	6	Positive terminal of Flying Capacitor 1. Connects a 1 $\mu$ F capacitor between C1P and C1N.
C1N	7	Negative Terminal of Flying Capacitor 1
C2N	8	Negative Terminal of Flying Capacitor 2
GND	9, 11	Ground.
VIN	10	Input Power Supply. Requires 1 $\mu$ F capacitor between this pin and ground.
D1	12	Current sink input #1. Connected to VOUT when un-used.
D2	13	Current sink input #2. Connected to VOUT when un-used.
D3	14	Current sink input #3. Connected to VOUT when un-used.
D4	15	Current sink input #4. Connected to VOUT when un-used.
D5	16	Current sink input #5. Connected to VOUT when un-used.
GND	EP PAD	Exposed Pad (bottom). Connected to GND directly underneath the package.

### Functional Block Diagram

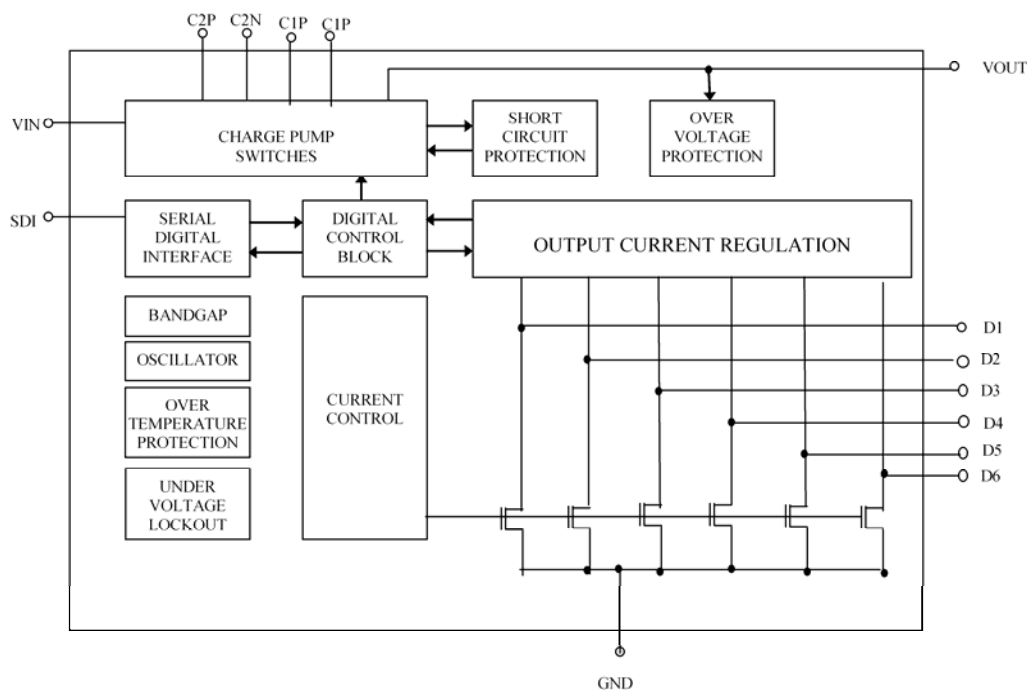

### Absolute Maximum Ratings (Note 3)

Symbol	Description	Rating	Unit
ESD HBM	Human Body Model ESD Protection	2	KV
ESD MM	Machine Model ESD Protection	200	V
$V_{IN}$	Input Voltage	-0.3 to 6	V
$V_{SDI}$	SDI to GND Voltage	-0.3 to $V_{IN} + 0.3$	V
$I_{OUT}$	Maximum DC Output Current	150	mA
$T_J$	Operating Junction Temperature Range	-40 to 150	°C
$T_{LEAD}$	Maximum Soldering Temperature (at leads, 10 sec)	300	°C

Notes: 3. Exceeding Absolute Maximum Ratings will cause permanent damage to the device.

### Recommended Operating Conditions

Symbol	Parameter	Min	Max	Units
$V_{IN}$	Input Voltage	2.7	5.5	V
$T_A$	Operating Ambient Temperature	-40	85	°C

### Electrical Characteristics

$C_{IN} = C_{OUT} = C_1 = C_2 = 1.0\mu F$ ;  $T_A = 25^\circ C$ ,  $V_{IN} = 3.5V$ . Unless otherwise noted.

Symbol	Parameter	Test Conditions	Min	Typ.	Max	Unit
$I_Q$	Quiescent Current	1X Mode, $3.0 \leq V_{IN} \leq 5.5$ , Active, No Load Current		0.3	1	mA
		1.5X Mode, $3.0 \leq V_{IN} \leq 5.5$ , Active, No Load Current		2.0	3	
		2X Mode, $3.0 \leq V_{IN} \leq 5.5$ , Active, No Load Current		1.5	3	
			50 $\mu A$ Setting, 1X Mode		50	
$I_{SHDN}$	Shutdown Current	SDI = 0			1	$\mu A$
$I_{DX}$	$I_{SINK}$ Current Accuracy (Note 4)	$I_{SET} = 20mA$ (Note 5), $T_A = 25^\circ C$	18.6	20	21.4	mA
		$I_{SET} = 4mA$ (Note 5), $T_A = 25^\circ C$	3.6	4	4.4	mA
$I_{D-Match}$	Current Matching Between Any Two Current Sink Inputs (Note 6)	$V_F$ : D1:D6 = 3.6V		0.5		%
$V_{TH}$	1X to 1.5X or 1.5X to 2X Transition Threshold at Any $I_{SINK}$ Pin	$I_{SET} = 25mA$		150		mV
<b>Charge Pump Section</b>						
$T_{SS}$	Soft-Start Time			40		$\mu s$
$F_{CLK}$	Clock Frequency			0.5/ 1/ 2		MHz
<b>SDI</b>						
$V_{SDI(L)}$	SDI Threshold Low	$V_{IN} = 2.7V$			0.4	V
$V_{SDI(H)}$	SDI Threshold High	$V_{IN} = 5.5V$	1.4			V
$T_{SLO}$	SDI Low Time		0.3		50	$\mu s$
$T_{SHI}$	SDI High Time		0.05		50	$\mu s$
$T_{OFF}$	SDI Off Timeout				256	$\mu s$
$T_{SEP}$	SDI Valid Sequence Timeout				256	$\mu s$
$I_{SDI}$	SDI Input Leakage		-1		1	$\mu A$
$\theta_{JA}$	Thermal Resistance Junction-to-Ambient	QFN4040-16 (Note 7)		46		$^\circ C/W$

- Notes:
4. Determined by the average current levels of all active channels
  5. Sequence setting set to give nominal 20mA max output current and 4mA output current.
  6. Defined as the deviation of any sink current from the average of all active current channels
  7. Device mounted on FR-4 substrate, 2"×2", 2oz, copper, double-sided PC board,

**Typical Performance Characteristics**

**Efficiency vs. Supply Voltage**

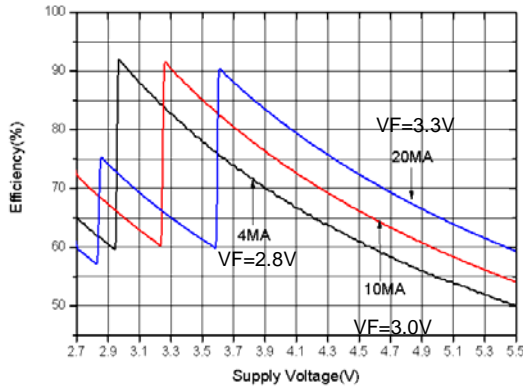

**Turn-On to 1X Mode  
(VIN = 4.2V; 20mA Load)**

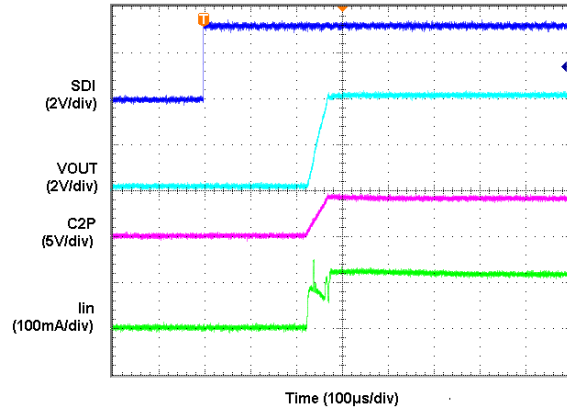

**Turn-On from 1.5X Mode  
(VIN = 3.5V; 20mA Load)**

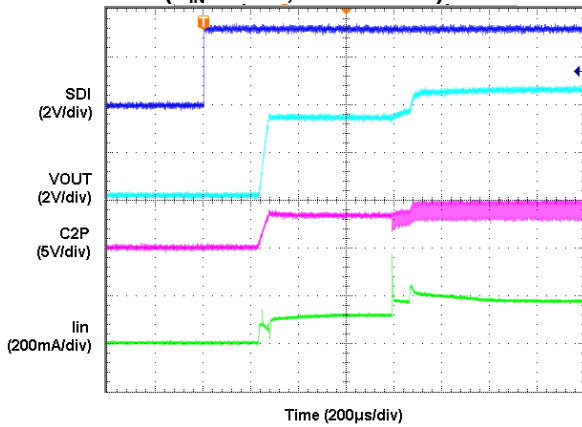

**Turn-On to 2X Mode  
(VIN = 2.7V; 20mA Load)**

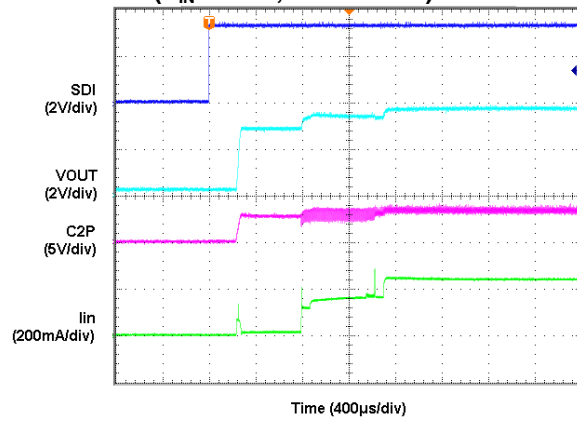

**Turn-Off from 1.5X Mode  
(VIN = 3.5V; 20mA Load)**

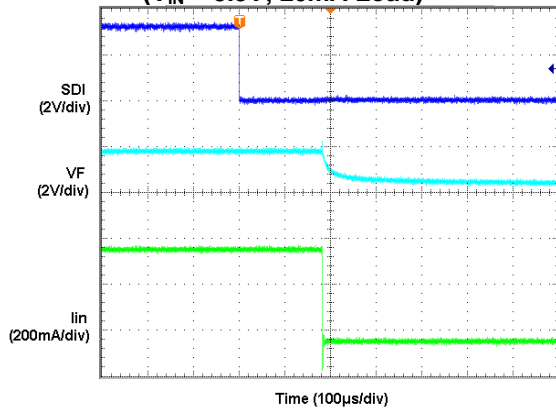

**Current Matching vs. Temperature**

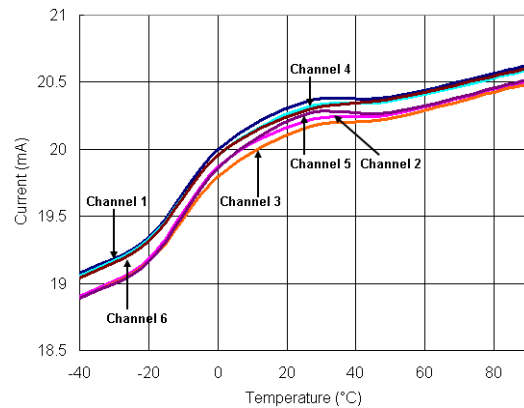

**Typical Performance Characteristics (Continued)**

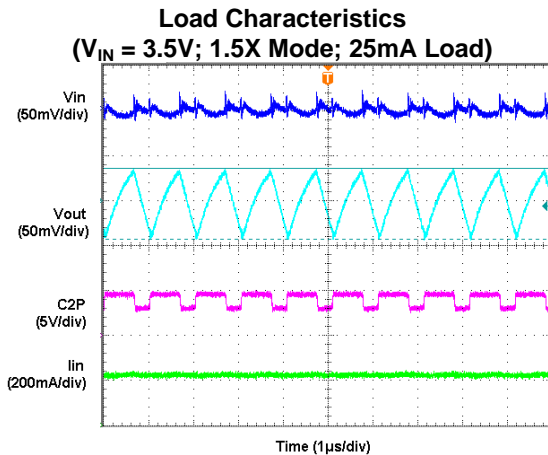
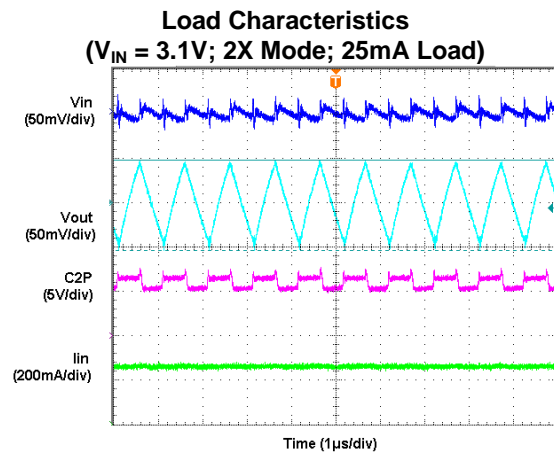
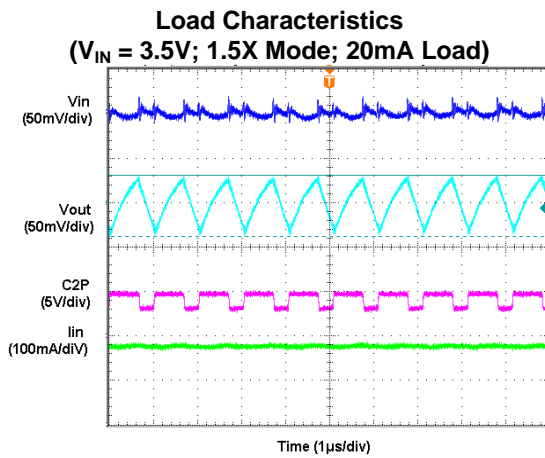
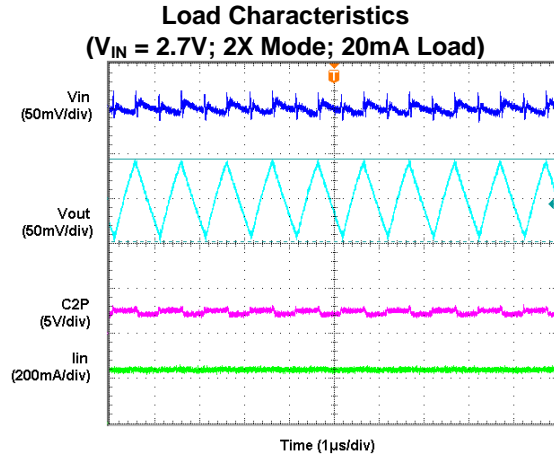
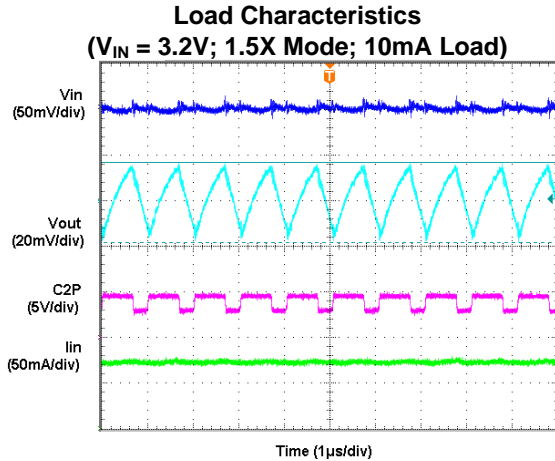

**Typical Performance Characteristics (Continued)**

**SDI Threshold High vs. Input Voltage**

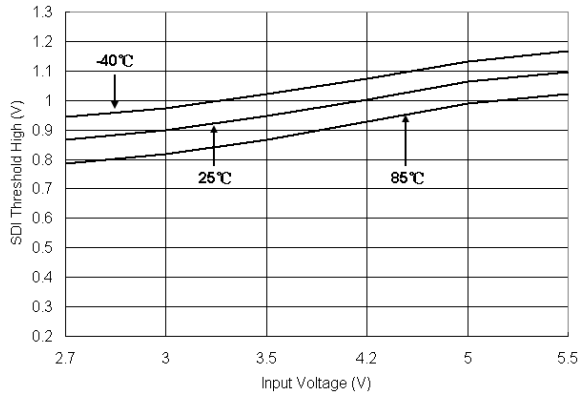

**SDI Threshold Low vs. Input Voltage**

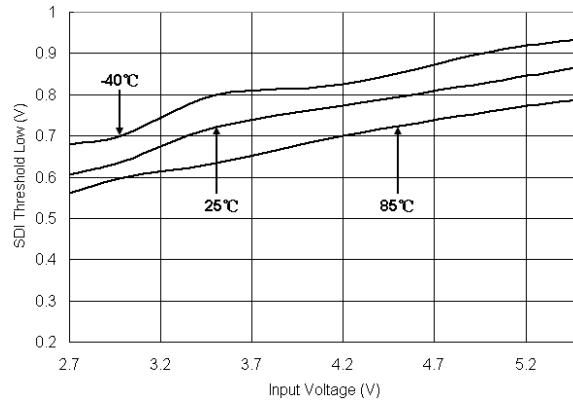



### Functional Description

The AP3156 is a tri-mode high efficiency six-channel charge pump (1x, 1.5x or 2x) device intended for white LED backlight applications. An internal comparator circuit compares the voltage at each constant current sink input against a reference voltage. To ensure maximum power efficiency, the most appropriate switching mode (1x, 1.5x, 2x) is automatically selected.

The AP3156 requires only four external components: two 1 $\mu$ F ceramic flying capacitors ( $C_1$  and  $C_2$ ) for the charge pump, one 1 $\mu$ F ceramic input capacitor ( $C_{IN}$ ), and one 1 $\mu$ F ceramic charge pump output capacitor ( $C_{OUT}$ ).

The each output channel of the AP3156 can drive six individual LEDs with a maximum current of 25mA per channel. These can be paralleled to give a total output current of 150mA.

#### Constant Current Output Level Settings

The constant current level for the outputs is set via the Serial Digital Interface and has a logarithmic variance. This results in the LED brightness varying linearly when the settings in the scale are traversed. Because the inputs D1 to D6 are true independent constant current sinks, the voltage observed on any single given input will be determined by the difference between  $V_{OUT}$  and the actual forward voltage ( $V_F$ ) of the LED being driven.

Since the constant current levels for the AP3156 are programmable, no PWM (pulse width modulation) or additional control circuitry is needed to control LED brightness. With its high-speed serial interface (>1MHz data rate), the LED current drive of the AP3156 can be changed successively to brighten or dim LEDs in smooth transitions or in abrupt steps, giving the user complete programmability and real-time control of LED brightness.

There are 32 current level settings separated from one another by approximately 0.5dB (see Constant Current Programming Level table). Code 1 is full-scale current, and Code 31 is full scale attenuated roughly 15dB. Code 32 is reserved as a "no current" setting.

#### Constant Current Programming Levels (mA)

Data	20mA Max $I_{OUT}$ (mA)	25mA Max $I_{OUT}$ (mA)
1	20	25
2	18.9	23.6
3	17.8	22.3
4	16.8	21.0
5	15.9	19.9
6	15.0	18.7
7	14.2	17.7
8	13.4	16.7
9	12.6	15.8
10	11.9	14.9
11	11.2	14.1
12	10.6	13.3
13	10.0	12.5
14	9.5	11.8
15	8.9	11.2
16	8.4	10.5
17	8.0	10.0
18	7.5	9.4
19	7.1	8.9

20	6.7	8.4
21	6.3	7.9
22	6.0	7.5
23	5.6	7.0
24	5.3	6.7
25	5.0	6.3
26	4.7	5.9
27	4.5	5.6
28	4.2	5.3
29	4.0	5.0
30	3.8	4.7
31	3.6	4.4
32	0	0

#### Low Current Output Level Setting

The AP3156 has a distinct Low Current mode with ultra-low quiescent current. For drive currents of 2mA or less, the device operates with significantly reduced quiescent current.

#### Low Current Programming Levels (mA)

Data	Current (mA)
1	2
2	1
3	0.5
4	0.05
5	0

#### Serial Digital Interface

SDI is a general purpose 1-wire digital interface designed to transport digital controls for power management ICs such as AP3156. The current levels of the six channels can be configured either together, individually or specific grouping. Up to 32 current levels are allowed. A generic system controller can easily support the SDI protocol via bit-banging over its general purpose I/Os.

The SDI protocol is simple yet flexible enough to accommodate different switching clock frequencies. Any sequence of negative-edged pulses of 63 or less (see Instruction & Data Table) separated by  $T_{SEP}$  at the SDI pin is interpreted by the AP3156 as a channel configuration event. In future, the number of pulses can be extended to support additional commands.

### Functional Description (Continued)

Instruction & Data Table

First Sequence	Second Sequence	Description
1~3	-	No Action
4~7	1~32	Reserved
8	1	Switching frequency selected to 0.5MHz
	2	Switching frequency selected to 1MHz (default)
	3	Switching frequency selected to 2MHz
	4~32	Reserved
9	1	20mA Constant Current Mode, 32 current level supported (default)
	2	Low Current Mode, 4 current level supported
	3	25mA Constant Current Mode, 32 current level supported
	4~32	Reserved
10	1~32*	Set current level for all 6 Channels
11	1~32*	Set current level for CH1, CH2, CH3
12	1~32*	Set current level for CH4, CH5, CH6
13	1~32*	Set current level for CH1, CH2, CH3, CH4
14	1~32*	Set current level for CH5, CH6
15	1~32*	Set current level for CH1, CH2, CH3, CH4, CH5
16	1~32*	Set current level for CH6
17	1~32*	Set current level for CH5
18	1~32*	Set current level for CH4
19	1~32*	Set current level for CH3
20	1~32*	Set current level for CH2
21	1~32*	Set current level for CH1
22~32	-	Reserved
33	-	Soft Reset 1) 1MHz switching frequency 2) 20mA Constant Current Mode 3) All Channels in Current Level Setting 32 (0mA)
34	-	Null Sequence
35~63	-	Reserved

\* Only 1~5 are valid current settings at Low Current Mode.

#### Disabled Current Sinks

Unused current channels must be disabled by connecting the sinks to VOUT with only a small sense current flowing through the disabled channel.

#### Soft-Start

Soft-start is incorporated to prevent excessive inrush current during power-up, mode switching, and transitioning out of stand-by mode.

#### Short-Circuit Protection

Short-circuit protection function is incorporated to prevent excessive load current when either flying cap terminals or output pin electrically tied to a very lower voltage or ground.

#### Over-Voltage Protection

Over-Voltage Protection function is incorporated to limit the output voltage under a safe value to avoid on-chip device breakdown.

#### Under-Voltage Lockout

Under-Voltage lockout feature disables the device when the input voltage drops below UVLO threshold.

#### Thermal Auto Shutdown

When the die temperature exceeds the thermal limit, the device will be disabled and enter stand-by mode. The operation resumes whenever the die cools off sufficiently.

#### Switching frequency

By default, the AP3156 is working at 1MHz switching frequency. It can also work at 0.5MHz or 2MHz switching frequency which can be set through the Serial Digital Interface. An user can choose the appropriate switching frequency with consideration of noise immunity, input and output voltage ripple requirement, and capacitor selection.

### Serial Digital Interface

#### SDI Command Timing Protocol

For the SDI command to be successfully received by the AP3156, all SDI timing specifications must be satisfied.

When no command is being sent, the SDI pin should be held High. If the SDI pin goes Low and stays Low for a time length between  $T_{SLO(min)}$  and  $T_{SLO(max)}$  and then goes High and stays High for the length between  $T_{SHI(min)}$  and  $T_{SHI(max)}$ , one falling edge is registered by the AP3156. The total number of falling edges registered before the SDI pin is held High for longer than the maximum separation time  $T_{SEP(max)}$  identifies the command that has been received by the AP3156. The next series of falling edges before another separation time of  $T_{SEP}$  represents the next command. In other words, the AP3156 counts the number of consecutive falling edges on the SDI pin and a different number represents a different command.

Each command is executed after it is successfully received. If at any time the SDI pin is held Low for longer than the maximum chip disable time  $T_{OFF(max)}$ , then the AP3156 will be turned off and enters the shutdown mode. Setting the SDI pin switching from Low to High will re-enable the AP3156 and leave the shutdown mode. If the SDI pin is held on for a time duration over  $T_{SEP}$ , then an end of a sequence (EOS) occurs with a number of pulse conformed to specified timing.

A valid dual-sequence command occurs when one valid sequence is defined as an instruction, and the other is defined as data. Both sequences have number of pulses less than 33. Also, a valid single-sequence command occurs when the sequence has number of pulses greater than 32.

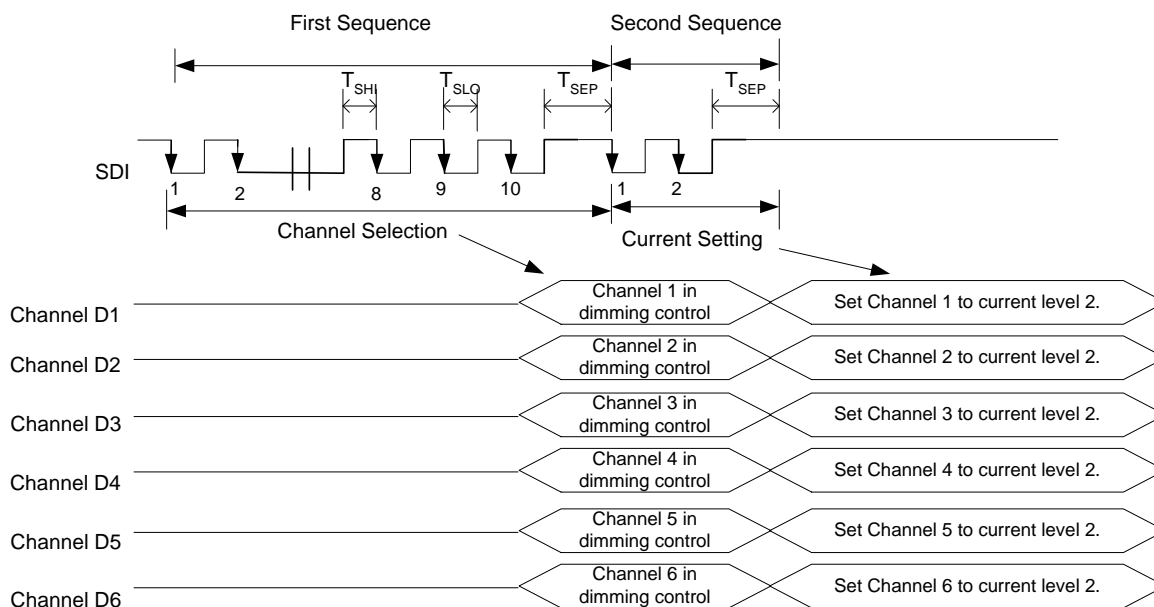
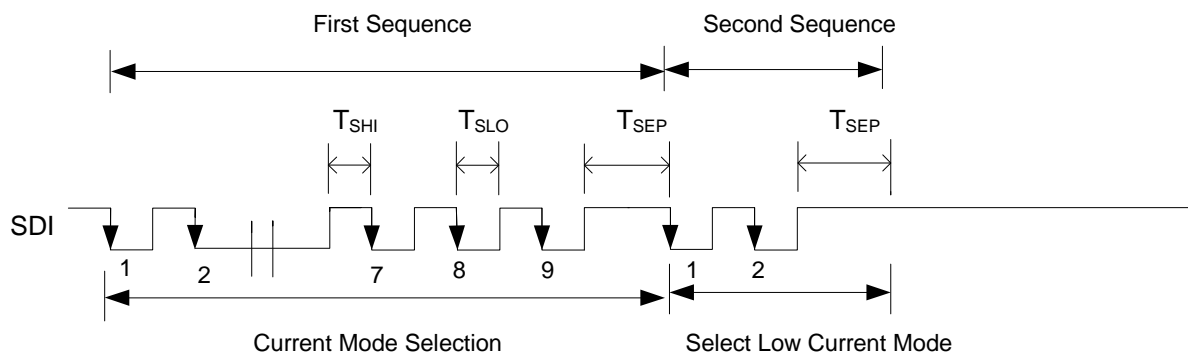
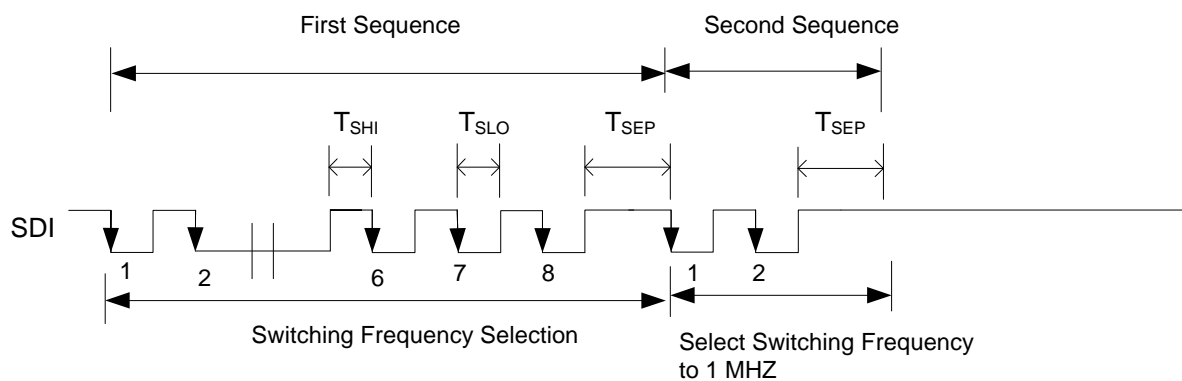

Figure 1: Dimming Control Selection (Dual-Sequence Command)

**Serial Digital Interface (Continued)**



**Figure 2: Current Mode Selection (Dual-Sequence Command)**



**Figure 3: Switching Frequency Selection (Dual-Sequence Command)**

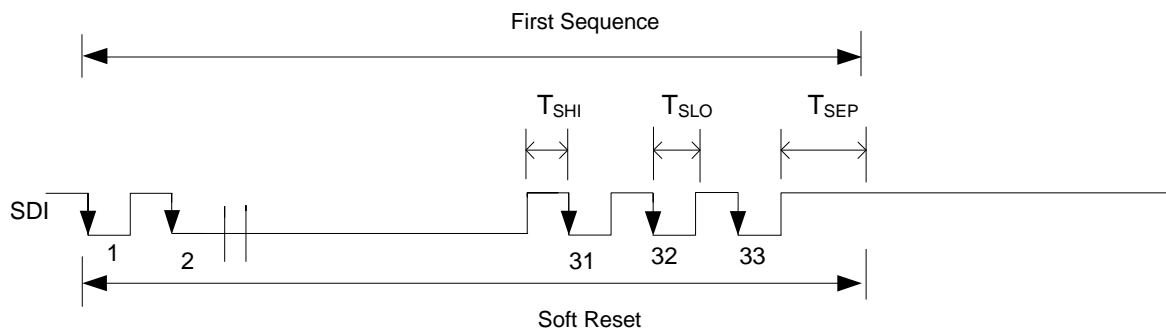

**Figure 4: Soft Reset (Single-Sequence Command)**



**Taping Orientation (Note 8)**

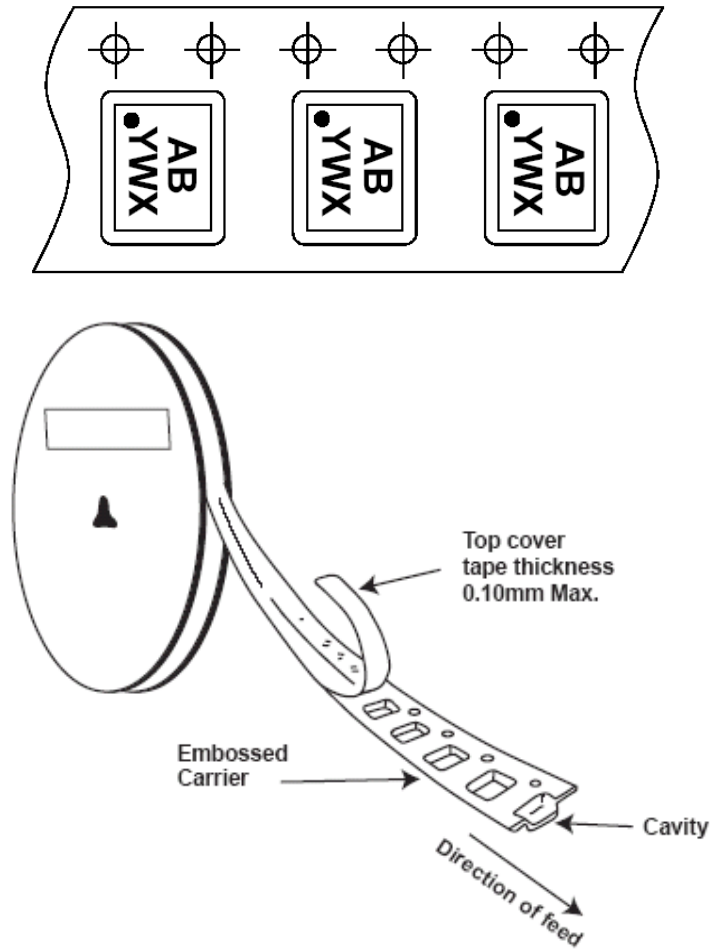

Note: 8. The taping orientation of the other package type can be found on our website at <http://www.diodes.com/datasheets/ap02007.pdf>

**IMPORTANT NOTICE**

DIODES INCORPORATED MAKES NO WARRANTY OF ANY KIND, EXPRESS OR IMPLIED, WITH REGARDS TO THIS DOCUMENT, INCLUDING, BUT NOT LIMITED TO, THE IMPLIED WARRANTIES OF MERCHANTABILITY AND FITNESS FOR A PARTICULAR PURPOSE (AND THEIR EQUIVALENTS UNDER THE LAWS OF ANY JURISDICTION).

Diodes Incorporated and its subsidiaries reserve the right to make modifications, enhancements, improvements, corrections or other changes without further notice to this document and any product described herein. Diodes Incorporated does not assume any liability arising out of the application or use of this document or any product described herein; neither does Diodes Incorporated convey any license under its patent or trademark rights, nor the rights of others. Any Customer or user of this document or products described herein in such applications shall assume all risks of such use and will agree to hold Diodes Incorporated and all the companies whose products are represented on Diodes Incorporated website, harmless against all damages.

Diodes Incorporated does not warrant or accept any liability whatsoever in respect of any products purchased through unauthorized sales channel.

Should Customers purchase or use Diodes Incorporated products for any unintended or unauthorized application, Customers shall indemnify and hold Diodes Incorporated and its representatives harmless against all claims, damages, expenses, and attorney fees arising out of, directly or indirectly, any claim of personal injury or death associated with such unintended or unauthorized application.

Products described herein may be covered by one or more United States, international or foreign patents pending. Product names and markings noted herein may also be covered by one or more United States, international or foreign trademarks.

**LIFE SUPPORT**

Diodes Incorporated products are specifically not authorized for use as critical components in life support devices or systems without the express written approval of the Chief Executive Officer of Diodes Incorporated. As used herein:

- A. Life support devices or systems are devices or systems which:
1. are intended to implant into the body, or
  2. support or sustain life and whose failure to perform when properly used in accordance with instructions for use provided in the labeling can be reasonably expected to result in significant injury to the user.
- B. A critical component is any component in a life support device or system whose failure to perform can be reasonably expected to cause the failure of the life support device or to affect its safety or effectiveness.

Customers represent that they have all necessary expertise in the safety and regulatory ramifications of their life support devices or systems, and acknowledge and agree that they are solely responsible for all legal, regulatory and safety-related requirements concerning their products and any use of Diodes Incorporated products in such safety-critical, life support devices or systems, notwithstanding any devices- or systems-related information or support that may be provided by Diodes Incorporated. Further, Customers must fully indemnify Diodes Incorporated and its representatives against any damages arising out of the use of Diodes Incorporated products in such safety-critical, life support devices or systems.

Copyright © 2009, Diodes Incorporated

[www.diodes.com](http://www.diodes.com)

Компания «Life Electronics» занимается поставками электронных компонентов импортного и отечественного производства от производителей и со складов крупных дистрибьюторов Европы, Америки и Азии.

С конца 2013 года компания активно расширяет линейку поставок компонентов по направлению коаксиальный кабель, кварцевые генераторы и конденсаторы (керамические, пленочные, электролитические), за счёт заключения дистрибьюторских договоров

Мы предлагаем:

- Конкурентоспособные цены и скидки постоянным клиентам.
- Специальные условия для постоянных клиентов.
- Подбор аналогов.
- Поставку компонентов в любых объемах, удовлетворяющих вашим потребностям.
- Приемлемые сроки поставки, возможна ускоренная поставка.
- Доставку товара в любую точку России и стран СНГ.
- Комплексную поставку.
- Работу по проектам и поставку образцов.
- Формирование склада под заказчика.
- Сертификаты соответствия на поставляемую продукцию (по желанию клиента).
- Тестирование поставляемой продукции.
- Поставку компонентов, требующих военную и космическую приемку.
- Входной контроль качества.
- Наличие сертификата ISO.

В составе нашей компании организован Конструкторский отдел, призванный помогать разработчикам, и инженерам.

Конструкторский отдел помогает осуществить:

- Регистрацию проекта у производителя компонентов.
- Техническую поддержку проекта.
- Защиту от снятия компонента с производства.
- Оценку стоимости проекта по компонентам.
- Изготовление тестовой платы монтаж и пусконаладочные работы.



Тел: +7 (812) 336 43 04 (многоканальный)

Email: [org@lifeelectronics.ru](mailto:org@lifeelectronics.ru)