Seven-channel QTouch® Touch Sensor IC

DATASHEET

Features

- Configurations:
 - Comms mode
 - Standalone mode
- Number of Keys:
 - Comms mode: 1 – 7 keys (or 1 – 6 keys plus a Guard Channel)
 - Standalone mode: 1 – 4 keys plus a fixed Guard Channel on key 0
- Number of I/O Lines:
 - Standalone mode: 5 outputs
- Technology:
 - Patented spread-spectrum charge-transfer
- Key Outline Sizes:
 - 6 mm x 6 mm or larger (panel thickness dependent); widely different sizes and shapes possible
- Layers Required:
 - One
- Electrode Materials:
 - Etched copper; Silver; Carbon; Indium Tin Oxide (ITO)
- Panel Materials:
 - Plastic; Glass; Composites; Painted surfaces (low particle density metallic paints possible)
- Panel Thickness:
 - Up to 10 mm glass; Up to 5 mm plastic (electrode size dependent)
- Key Sensitivity:
 - Comms mode: individually settable via simple commands over I²C-compatible interface
 - Standalone mode: settings are fixed
- Interface:
 - I²C-compatible slave mode (400 kHz). Discrete detection outputs
- Signal Processing:
 - Self-calibration
 - Auto drift compensation
 - Noise filtering
 - Adjacent Key Suppression® (AKS®) – up to three groups possible
- Power:
 - 1.8 V – 5.5 V
- Package:
 - 14-pin SOIC RoHS compliant IC
 - 20-pin VQFN RoHS compliant IC

1. Pinouts and Schematics

1.1 Pinout Configuration – Comms Mode (14-pin SOIC)

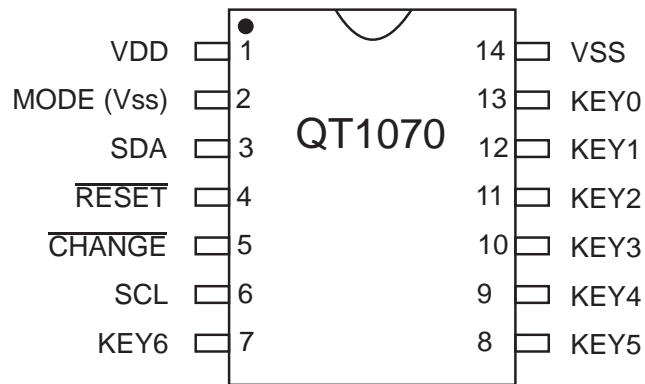

1.2 Pinout Configuration – Standalone Mode (14-pin SOIC)

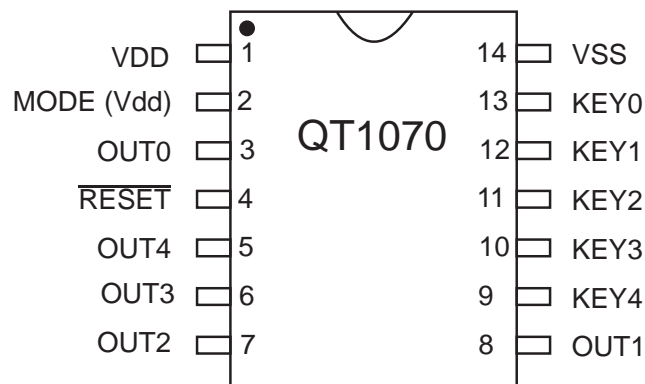

1.3 Pinout Configuration – Comms Mode (20-pin VQFN)

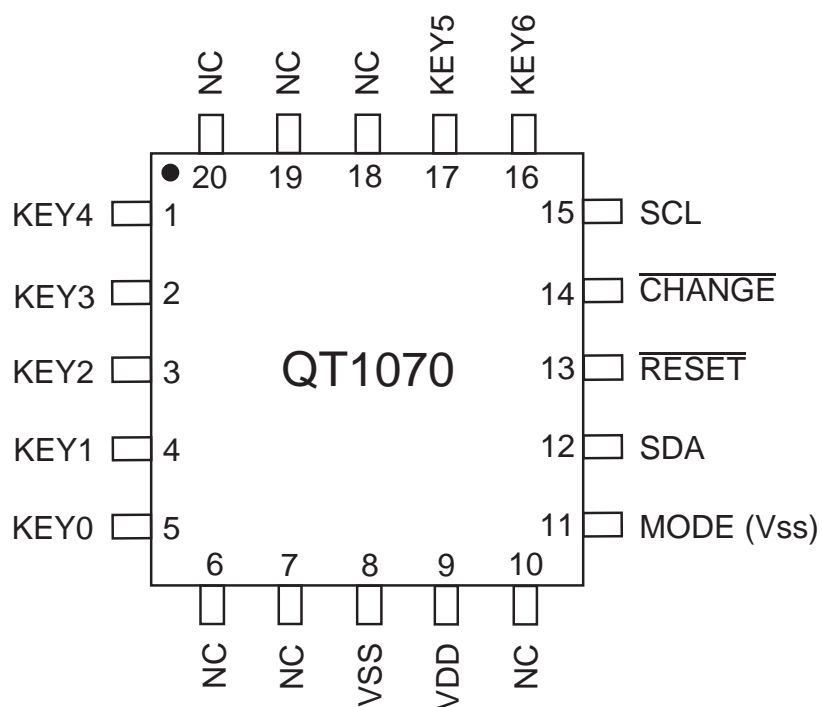

1.4 Pinout Configuration – Standalone Mode (20-pin VQFN)

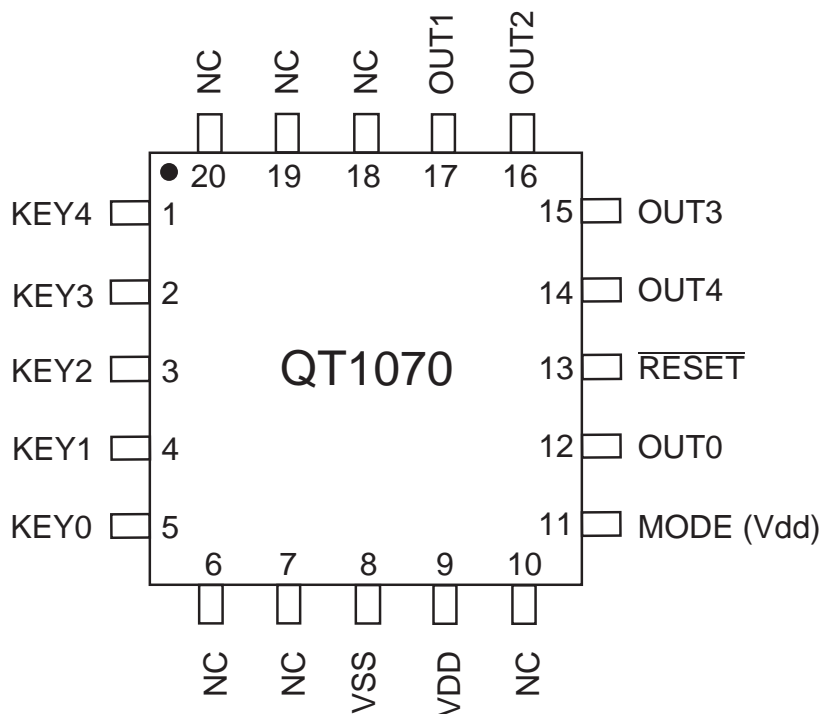

1.5 Pin Descriptions

Table 1-1. Pin Listings (14-pin SOIC)

Pin	Name (Comms Mode)	Name (Standalone Mode)	Type	Description	If Unused, Connect To...
1	VDD	VDD	P	Power	–
2	MODE	MODE	I	Mode selection pin Comms Mode – connect to Vss Standalone Mode – connect to Vdd	–
3	SDA	OUT0	OD	Comms Mode – I ² C data line Standalone Mode – open drain output for guard channel	Open
4	$\overline{\text{RESET}}$	$\overline{\text{RESET}}$	I	$\overline{\text{RESET}}$ – has internal pull-up 60 k Ω resistor	Open
5	$\overline{\text{CHANGE}}$	OUT4	OD	$\overline{\text{CHANGE}}$ line for controlling the communications flow Comms Mode – connect to $\overline{\text{CHANGE}}$ line Standalone Mode – connect to output	Open
6	SCL	OUT3	OD	Comms Mode – connect to I ² C clock Standalone Mode – connect to output	Open
7	KEY6	OUT2	O/OD	Comms Mode – connect to Key 6 Standalone Mode – connect to output	Open
8	KEY5	OUT1	O/OD	Comms Mode – connect to Key 5 Standalone Mode – connect to output	Open
9	KEY4	KEY4	O	Key 4	Open
10	KEY3	KEY3	O	Key 3	Open
11	KEY2	KEY2	O	Key 2	Open
12	KEY1	KEY1	O	Key 1	Open
13	KEY0	KEY0	O	Key 0	Open
14	VSS	VSS	P	Ground	–

I Input only
OD Open drain output

O Output only, push-pull
P Ground or power

Table 1-2. Pin Listings (20-pin VQFN)

Pin	Name (Comms Mode)	Name (Standalone Mode)	Type	Description	If Unused, Connect To...
1	KEY4	KEY4	O	Key 4	Open
2	KEY3	KEY3	O	Key 3	Open
3	KEY2	KEY2	O	Key 2	Open
4	KEY1	KEY1	O	Key 1	Open
5	KEY0	KEY0	O	Key 0	Open
6	NC	NC	–	Not connected	–
7	NC	NC	–	Not connected	–
8	VSS	VSS	P	Ground	–
9	VDD	VDD	P	Power	–
10	NC	NC	–	Not connected	–
11	MODE	MODE	I	Mode selection pin Comms Mode – connect to Vss Standalone Mode – connect to Vdd	–
12	SDA	OUT0	OD	Comms Mode – I ² C data line Standalone Mode – open drain output for guard channel	Open
13	$\overline{\text{RESET}}$	$\overline{\text{RESET}}$	I	$\overline{\text{RESET}}$ – has internal pull-up 60 k Ω resistor	Open
14	$\overline{\text{CHANGE}}$	OUT4	OD	$\overline{\text{CHANGE}}$ line for controlling the communications flow Comms Mode – connect to $\overline{\text{CHANGE}}$ line Standalone Mode – connects to output	Open
15	SCL	OUT3	OD	Comms Mode – connect to I ² C clock Standalone Mode – connect to output	Open
16	KEY6	OUT2	O/OD	Comms Mode – connect to Key 6 Standalone Mode – connect to output	Open
17	KEY5	OUT1	O/OD	Comms Mode – connect to Key 5 Standalone Mode – connect to output	Open
18	NC	NC	–	Not connected	–
19	NC	NC	–	Not connected	–
20	NC	NC	–	Not connected	–

I Input only
OD Open drain output

O Output only, push-pull
P Ground or power

1.6 Schematics

Figure 1-1. Typical Circuit – Comms (14-pin SOIC)

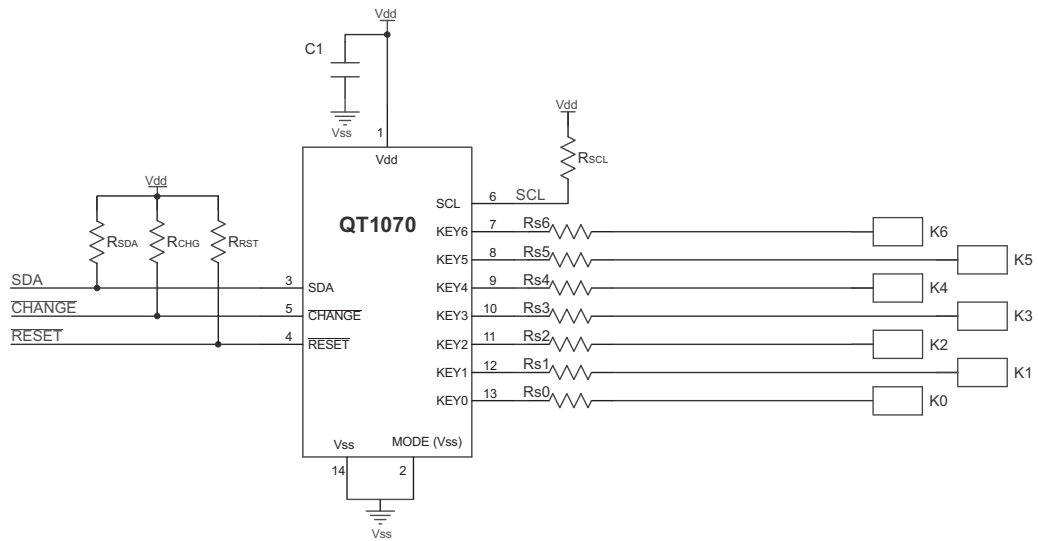

Figure 1-2. Typical Circuit – Standalone (14-pin SOIC)

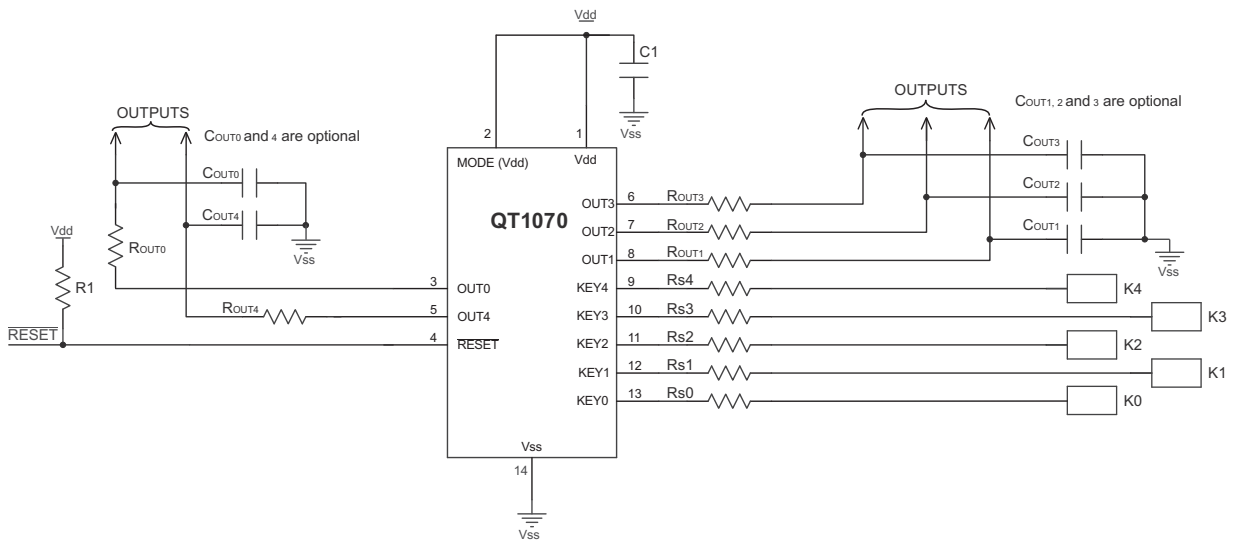

Figure 1-3. Typical Circuit – Comms (20-pin VQFN)

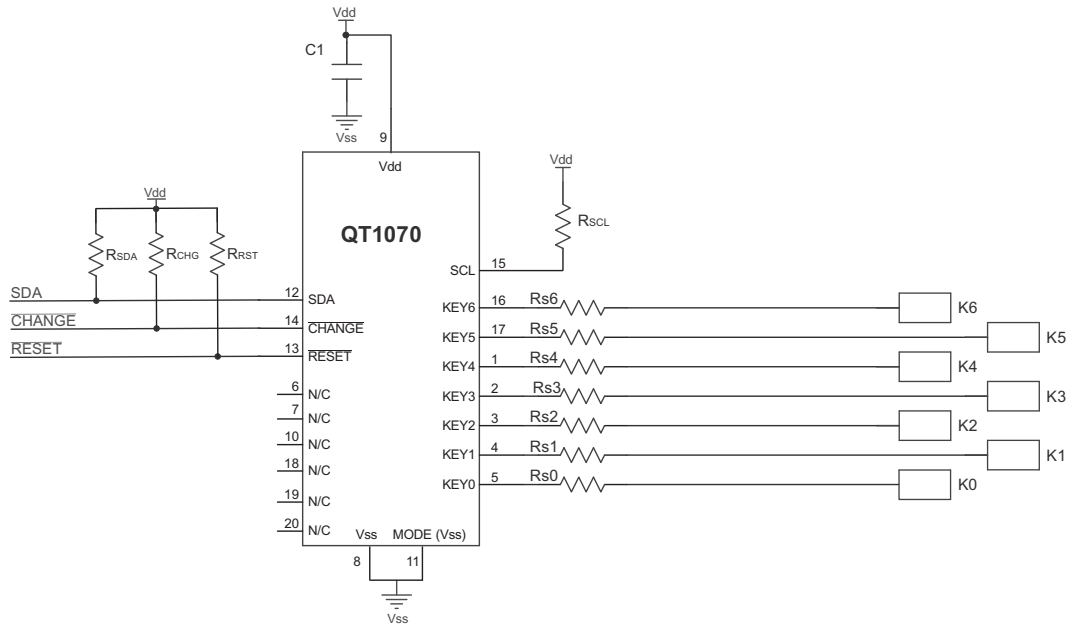
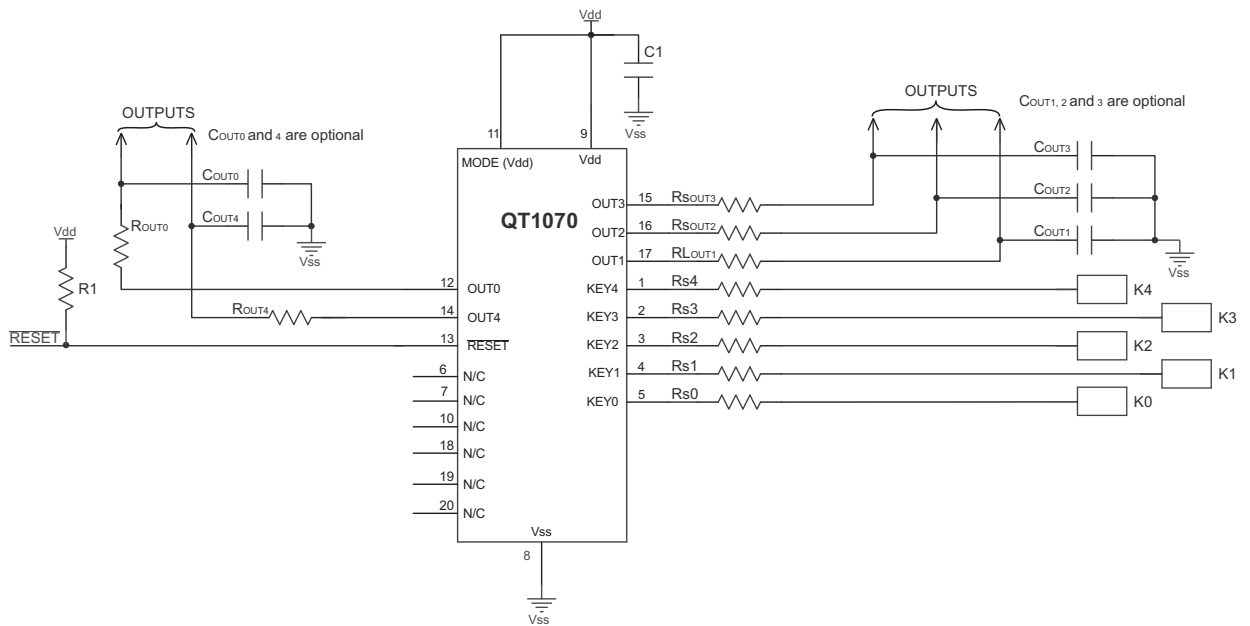

Figure 1-4. Typical Circuit – Standalone (20-pin VQFN)



For component values in [Figure 1-1](#), [1-2](#), [1-3](#), and [1-4](#), check the following sections:

[Section 3.1 on page 12](#): Series resistors (Rs0 – Rs6 for comms mode and Rs0 – Rs4 for standalone mode)

[Section 3.2 on page 12](#): LED traces

[Section 3.4 on page 12](#): Power Supply (voltage levels)

[Section 4.4 on page 14](#): SDA, SCL pull-up resistors

2. Overview

2.1 Introduction

The AT42QT1070 (QT1070) is a digital burst mode charge-transfer (QT™) capacitive sensor driver. The device can sense from one to seven keys, dependent on mode.

The QT1070 includes all signal processing functions necessary to provide stable sensing under a wide variety of changing conditions, and the outputs are fully debounced. Only a few external parts are required for operation and no external Cs capacitors are required.

The QT1070 modulates its bursts in a spread-spectrum fashion in order to heavily suppress the effects of external noise, and to suppress RF emissions. The QT1070 uses a dual-pulse method of acquisition. This provides greater noise immunity and eliminates the need for external sampling capacitors, allowing touch sensing using a single pin.

2.2 Modes

2.2.1 Comms Mode

The QT1070 can operate in comms mode where a host can communicate with the device via an I²C bus. This allows the user to configure settings for Threshold, Adjacent Key Suppression (AKS), Detect Integrator, Low Power (LP) Mode, Guard Channel and Max Time On for keys.

2.2.2 Standalone Mode

The QT1070 can operate in a standalone mode where an I²C interface is not required. To enter standalone mode, connect the Mode pin to Vdd before powering up the QT1070.

In standalone mode, the start-up values are hard coded in firmware and cannot be changed. The default start-up values are used. This means that key detection is reported via their respective IOs. The Guard channel feature is automatically implemented on key 0 in standalone mode. This means that this channel gets priority over all other keys going into touch.

2.3 Keys

Dependent on mode, the QT1070 can have a minimum of one key and a maximum of seven keys. These can be constructed in different shapes and sizes. See [“Features” on page 1](#) for the recommended dimensions.

- Comms mode – 1 to 7 keys (or 1 to 6 keys plus Guard Channel)
- Standalone mode – 1 to 4 keys plus a Guard Channel

Unused keys should be disabled by setting the averaging factor to zero (see [Section 5.9 on page 18](#)).

The status register can be read to determine the touch status of the corresponding key. It is recommended using the open-drain CHANGE line to detect when a change of status has occurred.

2.4 Input/Output (IO) Lines

There are no IO lines in comms mode.

In Standalone mode pins OUT0 – OUT4 can be used as open drain outputs for driving LEDs.

2.5 Acquisition/Low Power Mode (LP)

There are 255 different acquisition times possible. These are controlled via the LP mode byte (see [Section 5.11 on page 19](#)) which can be written to via I²C communication.

LP mode controls the intervals between acquisition measurements. Longer intervals consume lower power but have an increased response time. During calibration, touch and during the detect integrator (DI) period, the LP mode is temporarily set to LP mode 1 for a faster response.

The QT1070 operation is based on a fixed cycle time of approximately 8 ms. The LP mode setting indicates how many of these periods exist per measurement cycle. For example, if LP mode = 1, there is an acquisition every cycle (8 ms). If LP mode = 3, there is an acquisition every 3 cycles (24 ms). If a high Averaging Factor (see [Section 5.9 on page 18](#)) setting is selected then the acquisition time may exceed 8 ms.

LP settings above mode 32 (256 ms) result in slower thermal drift compensation and should be avoided in applications where fast thermal transients occur.

2.6 Adjacent Key Suppression (AKS) Technology

The device includes the Atmel-patented Adjacent Key Suppression (AKS) technology, to allow the use of tightly spaced keys on a keypad with no loss of selectability by the user.

There can be up to three AKS groups, implemented so that only one key in the group may be reported as being touched at any one time. Once a key in a particular AKS group is in detect no other key in that group can go into detect. Only when the key in detect goes out of detection can another key go into detect state.

The keys which are members of the AKS groups can be set (see [Section 5.9 on page 18](#)). Keys outside the group may be in detect simultaneously.

2.7 CHANGE Line (Comms Mode Only)

The $\overline{\text{CHANGE}}$ line is active low and signals when there is a change of state in the Detection or Input key status bytes. It is cleared (allowed to float high) when the host reads the status bytes.

If the status bytes change back to their original state before the host has read the status bytes (for example, a touch followed by a release), the $\overline{\text{CHANGE}}$ line will be held low. In this case, a read to any memory location will clear the $\overline{\text{CHANGE}}$ line.

The $\overline{\text{CHANGE}}$ line is open-drain and should be connected via a 47 k Ω resistor to Vdd. It is necessary for minimum power operation as it ensures that the QT1070 can sleep for as long as possible. Communications wake up the QT1070 from sleep causing a higher power consumption if the part is randomly polled.

Note: The $\overline{\text{CHANGE}}$ line is pulled low 100 ms after power-up or reset.

2.8 Types of Reset

2.8.1 External Reset

An external reset logic line can be used if desired, fed into the $\overline{\text{RESET}}$ pin. However, under most conditions it is acceptable to tie $\overline{\text{RESET}}$ to Vdd.

2.8.2 Soft Reset

The host can cause a device reset by writing a nonzero value to the $\overline{\text{RESET}}$ byte. This soft reset triggers the internal watchdog timer on a 125 ms interval. After 125 ms the device resets and wakes again.

The device NACKs any attempts to communicate with it during the first 30 ms of its initialization period.

2.9 Calibration

Writing a non-zero value to the calibration byte can force a recalibration at any time. This can be useful to clear out a stuck key condition after a prolonged period of uninterrupted detection.

Note: A calibrate command clears all key status bits and the overflow bit (until it is checked on the next cycle).

2.10 Guard Channel

A guard channel to help prevent false detection is available in both modes. This is fixed on key 0 for standalone mode and programmable for comms mode.

Guard channel keys should be more sensitive than the other keys (physically bigger). Because the guard channel key is physically bigger it becomes more susceptible to noise so it has a higher Averaging Factor (see [Section 5.9 on page 18](#)) and a lower Threshold (see [Section 5.8 on page 18](#)) than the other keys. In standalone mode it has an Averaging Factor of 16 and a Threshold of 10 counts.

A channel set as the guard channel (there can only be one) is prioritised when the filtering of keys going into detect is taking place. So if a normal key is filtering into touch (touch present but DI has not been reached) and the key set as the guard key begins filtering in, then the normal key's filter is reset and the guard key filters in first.

The guard channel is connected to a sensor pad which detects the presence of touch and overrides any output from the other keys.

Figure 2-1. Guard Channel Example

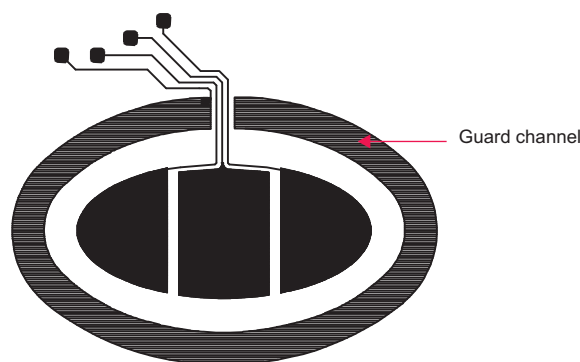

2.11 Signal Processing

2.11.1 Detect Threshold

The device detects a touch when the signal has crossed a threshold level and remained there for a specified number of counts (see [Section 5.10 on page 19](#)). This can be altered on a key-by-key basis using the key threshold I²C commands.

In standalone mode the detect threshold is set to a fixed value of 10 counts of change with respect to the internal reference level for the guard channel and 20 counts for the other four keys. The reference level has the ability to adjust itself slowly in accordance with the drift compensation mechanism.

The drift mechanism will drift toward touch at a rate of $160 \text{ ms} \times 18 = 2.88$ seconds and away from touch at a rate of $160 \text{ ms} \times 6 = 0.96$ seconds. The 160 ms is based on $20 \times 8 \text{ ms}$ cycles. If the cycle time exceeds 8 ms then the overall times will be extended to match.

2.11.2 Detect Integrator

The device features a fast detection integrator counter (DI filter), which acts to filter out noise at the small expense of a slower response time. The DI filter requires a programmable number of consecutive samples confirmed in detection before the key is declared to be touched. The minimum number for the DI filter is 2. Settings of 0 and 1 for the DI also default to 2.

The DI is also implemented when a touch is removed. This uses the Fast Out DI option. When bit 5 of Address 53 is set the a key filters out with an integrator of 4.

2.11.3 Cx Limitations

The recommended range for key capacitance Cx is 1 pF – 30 pF. Larger values of Cx will give reduced sensitivity.

2.11.4 Max On Duration

If an object or material obstructs the sense pad the signal may rise enough to create a detection, preventing further operation. To prevent this, the sensor includes a timer which monitors detections. If a detection exceeds the timer setting the sensor performs a key recalibration. This is known as the Max On duration feature and is set to approximately 30 s in standalone mode.

In comms mode this feature can be changed by setting a value in the range 1 – 255 (160 ms – 40,800 ms) in steps of 160 ms. A setting of 0 disables the Max On Duration recalibration feature.

Note: If bit 4 of address 53 is clear then a recalibration of all keys occurs on Max On Duration, otherwise individual key recalibration occurs.

2.11.5 Positive Recalibration

If a keys signal jumps in the negative direction (with respect to its reference) by more than the Positive Recalibration setting (4 counts), then a recalibration of that key takes place.

2.11.6 Drift Hold Time

Drift Hold Time (DHT) is used to restrict drift on all keys while one or more keys are activated. DHT restricts the drifting on all keys until approximately four seconds after all touches have been removed.

This feature is particularly useful in cases of high-density keypads where touching a key or hovering a finger over the keypad would cause untouched keys to drift, and therefore create a sensitivity shift, and ultimately inhibit touch detection.

2.11.7 Hysteresis

Hysteresis is fixed at 12.5% of the Detect Threshold. When a key enters a detect state once the DI count has been reached, the NTHR value is changed by a small amount (12.5% of NTHR) in the direction away from touch. This is done to affect hysteresis and so makes it less likely a key will dither in and out of detect. NTHR is restored once the key drops out of detect.+

3. Wiring and Parts

3.1 Rs Resistors

Series resistors R_s ($R_{s0} - R_{s6}$ for comms mode and $R_{s0} - R_{s4}$ for standalone mode) are in line with the electrode connections and should be used to limit electrostatic discharge (ESD) currents and to suppress radio frequency interference (RFI). Series resistors are recommended for noise reduction. They should be approximately $4.7\text{ k}\Omega$ to $20\text{ k}\Omega$ each.

3.2 LED Traces and Other Switching Signals

Digital switching signals near the sense lines induce transients into the acquired signals, deteriorating the signal-to-noise (SNR) performance of the device. Such signals should be routed away from the sensing traces and electrodes, or the design should be such that these lines are not switched during the course of signal acquisition (bursts).

LED terminals which are multiplexed or switched into a floating state, and which are within, or physically very near, a key (even if on another nearby PCB) should be bypassed to either V_{ss} or V_{dd} with at least a 10 nF capacitor. This is to suppress capacitive coupling effects which can induce false signal shifts. The bypass capacitor does not need to be next to the LED, in fact it can be quite distant. The bypass capacitor is noncritical and can be of any type.

LED terminals which are constantly connected to V_{ss} or V_{dd} do not need further bypassing.

3.3 PCB Cleanliness

Modern no-clean flux is generally compatible with capacitive sensing circuits.



CAUTION: If a PCB is reworked in any way, it is highly likely that the behavior of the no-clean flux will change. This can mean that the flux changes from an inert material to one that can absorb moisture and dramatically affect capacitive measurements due to additional leakage currents. If so, the circuit can become erratic and exhibit poor environmental stability.

If a PCB is reworked in any way, clean it thoroughly to remove all traces of the flux residue around the capacitive sensor components. Dry it thoroughly before any further testing is conducted.

3.4 Power Supply

See [Section 6.2 on page 22](#) for the power supply range. If the power supply fluctuates slowly with temperature, the device tracks and compensates for these changes automatically with only minor changes in sensitivity. If the supply voltage drifts or shifts quickly, the drift compensation mechanism is not able to keep up, causing sensitivity anomalies or false detections.

The usual power supply considerations with QT parts apply to the device. The power should be clean and come from a separate regulator if possible. However, this device is designed to minimize the effects of unstable power, and except in extreme conditions should not require a separate Low Dropout (LDO) regulator.



CAUTION: A regulator IC shared with other logic can result in erratic operation and is **not** advised.

A single ceramic $0.1\text{ }\mu\text{F}$ bypass capacitor, with short traces, should be placed very close to the power pins of the IC. Failure to do so can result in device oscillation, high current consumption and erratic operation.

It is assumed that a larger bypass capacitor (such as $1\text{ }\mu\text{F}$) is somewhere else in the power circuit; for example, near the regulator.

4. I²C Communications (Comms Mode Only)

4.1 I²C Protocol

4.1.1 Protocol

The I²C protocol is based around access to an address table (see [Table 5-1 on page 15](#)) and supports multibyte reads and writes. The maximum clock rate is 400 kHz.

See [Section A. on page 29](#) for an overview of I²C bus operation.

4.1.2 Signals

The I²C interface requires two signals to operate:

- **SDA** - Serial Data
- **SCL** - Serial Clock

A third line, $\overline{\text{CHANGE}}$, is used to signal when the device has seen a change in the status byte:

CHANGE: Open-drain, active low when any capacitive key has changed state since the last I²C read. After reading the two status bytes, this pin floats (high) again if it is pulled up with an external resistor. If the status bytes change back to their original state before the host has read the status bytes (for example, a touch followed by a release), the $\overline{\text{CHANGE}}$ line is held low. In this case, a read to any memory location clears the $\overline{\text{CHANGE}}$ line.

4.2 I²C Address

There is one preset I²C address of 0x1B. This is not changeable.

4.3 Data Read/Write

4.3.1 Writing Data to the Device

The sequence of events required to write data to the device is shown next.

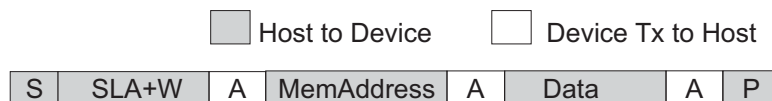

Table 4-1. Description of Write Data Bits

Key	Description
S	START condition
SLA+W	Slave address plus write bit
A	Acknowledge bit
MemAddress	Target memory address within device
Data	Data to be written
P	Stop condition

1. The host initiates the transfer by sending the START condition
2. The host follows this by sending the slave address of the device together with the WRITE bit.
3. The device sends an ACK.

4. The host then sends the memory address within the device it wishes to write to.
5. The device sends an ACK if the write address is in the range $0x00 - 0x7F$, otherwise it sends a NACK.
6. The host transmits one or more data bytes; each is acknowledged by the device (unless trying to write to an invalid address).
7. If the host sends more than one data byte, they are written to consecutive memory addresses.
8. The device automatically increments the target memory address after writing each data byte.
9. After writing the last data byte, the host should send the STOP condition.

Note: the host should not try to write to addresses outside the range $0x20$ to $0x39$ because this is the limit of the device internal memory address.

4.3.2 Reading Data From the Device

The sequence of events required to read data from the device is shown next.

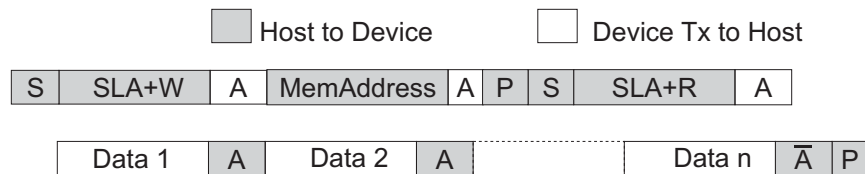

1. The host initiates the transfer by sending the START condition
2. The host follows this by sending the slave address of the device together with the WRITE bit.
3. The device sends an ACK.
4. The host then sends the memory address within the device it wishes to read from.
5. The device sends an ACK if the address to be read from is less than $0x80$ otherwise it sends a NACK).
6. The host must then send a STOP and a START condition followed by the slave address again but this time accompanied by the READ bit.

Note: Alternatively, instead of step 6 a repeated START can be sent so the host does not need to relinquish control of the bus.

7. The device returns an ACK, followed by a data byte.
8. The host must return either an ACK or NACK.
 1. If the host returns an ACK, the device subsequently transmits the data byte from the next address. Each time a data byte is transmitted, the device automatically increments the internal address. The device continues to return data bytes until the host responds with a NACK.
 2. If the host returns a NACK, it should then terminate the transfer by issuing the STOP condition.
9. The device resets the internal address to the location indicated by the memory address sent to it previously. Therefore, there is no need to send the memory address again when reading from the same location.

Note: Reading the 16-bit reference and signal values is not an automatic operation; reading the first byte of a 16-bit value does not lock the other byte. As a result glitches in the reported value may be seen as values increase from 255 to 256, or decrease from 256 to 255.

4.4 SDA, SCL

The I²C bus transmits data and clock with SDA and SCL respectively. They are open-drain; that is I²C master and slave devices can only drive these lines low or leave them open. The termination resistors pull the line up to V_{dd} if no I²C device is pulling it down.

The termination resistors commonly range from 1 k Ω to 10 k Ω and should be chosen so that the rise times on SDA and SCL meet the I²C specifications (1 μ s maximum).

Standalone mode: if I²C communications are not required, then standalone mode can be enabled by connecting the MODE pin to V_{dd}. See [Section 2.4 on page 8](#) for more information.

5. Setups

5.1 Introduction

The device calibrates and processes signals using a number of algorithms specifically designed to provide for high survivability in the face of adverse environmental challenges. User-defined Setups are employed to alter these algorithms to suit each application. These Setups are loaded into the device over the I²C serial interfaces. In standalone mode these settings are fixed to predetermined values.

Table 5-1. Internal Register Address Allocation

Address	Use	Bit 7	Bit 6	Bit 5	Bit 4	Bit 3	Bit 2	Bit 1	Bit 0	R/W
0	Chip ID	Major ID (= 2)				Minor ID (= E)				R
1	Firmware Version	Firmware version number								R
2	Detection status	CALIBRATE	OVERFLOW	–	–	–	–	–	TOUCH	R
3	Key status	Reserved	Key 6	Key 5	Key 4	Key 3	Key 2	Key 1	Key 0	R
4 – 5	Key signal 0	Key signal 0 (MSByte) – Key signal 0 (LSByte)								R
6 – 7	Key signal 1	Key signal 1 (MSByte) – Key signal 1 (LSByte)								R
8 – 9	Key signal 2	Key signal 2 (MSByte) – Key signal 2 (LSByte)								R
10 – 11	Key signal 3	Key signal 3 (MSByte) – Key signal 3 (LSByte)								R
12 – 13	Key signal 4	Key signal 4 (MSByte) – Key signal 4 (LSByte)								R
14 – 15	Key signal 5	Key signal 5 (MSByte) – Key signal 5 (LSByte)								R
16 – 17	Key signal 6	Key signal 6 (MSByte) – Key signal 6 (LSByte)								R
18 – 19	Reference data 0	Reference data 0 (MSByte) – Reference data 0 (LSByte)								R
20 – 21	Reference data 1	Reference data 1 (MSByte) – Reference data 1 (LSByte)								R
22 – 23	Reference data 2	Reference data 2 (MSByte) – Reference data 2 (LSByte)								R
24 – 25	Reference data 3	Reference data 3 (MSByte) – Reference data 3 (LSByte)								R
26 – 27	Reference data 4	Reference data 4 (MSByte) – Reference data 4 (LSByte)								R
28 – 29	Reference data 5	Reference data 5 (MSByte) – Reference data 5 (LSByte)								R
30 – 31	Reference data 6	Reference data 6 (MSByte) – Reference data 6 (LSByte)								R
32	NTHR key 0	Negative Threshold level for key 0								R/W
33	NTHR key 1	Negative Threshold level for key 1								R/W
34	NTHR key 2	Negative Threshold level for key 2								R/W
35	NTHR key 3	Negative Threshold level for key 3								R/W
36	NTHR key 4	Negative Threshold level for key 4								R/W
37	NTHR key 5	Negative Threshold level for key 5								R/W
38	NTHR key 6	Negative Threshold level for key 6								R/W
39	AVE/AKS key 0	Adjacent key suppression level for key 0								R/W
40	AVE/AKS key 1	Adjacent key suppression level for key 1								R/W

Table 5-1. Internal Register Address Allocation (Continued)

Address	Use	Bit 7	Bit 6	Bit 5	Bit 4	Bit 3	Bit 2	Bit 1	Bit 0	R/W
41	AVE/AKS key 2	Adjacent key suppression level for key 2								R/W
42	AVE/AKS key 3	Adjacent key suppression level for key 3								R/W
43	AVE/AKS key 4	Adjacent key suppression level for key 4								R/W
44	AVE/AKS key 5	Adjacent key suppression level for key 5								R/W
45	AVE/AKS key 6	Adjacent key suppression level for key 6								R/W
46	DI key 0	Detection integrator counter for key 0								R/W
47	DI key 1	Detection integrator counter for key 1								R/W
48	DI key 2	Detection integrator counter for key 2								R/W
49	DI key 3	Detection integrator counter for key 3								R/W
50	DI key 4	Detection integrator counter for key 4								R/W
51	DI key 5	Detection integrator counter for key 5								R/W
52	DI key 6	Detection integrator counter for key 6								R/W
53	FO/MO/Guard No	FastOutDI/ Max Cal/Guard Channel								R/W
54	LP	Low Power (LP) Mode								R/W
55	Max On Duration	Maximum On Duration								R/W
56	Calibrate	Calibrate								R/W
57	RESET	RESET								R/W

5.2 Address 0: Chip ID

Table 5-2. Chip ID

Address	b7	b6	b5	b4	b3	b2	b1	b0
0	MAJOR ID				MINOR ID			

MAJOR ID: Reads back as 2

MINOR ID: Reads back as E

5.3 Address 1: Firmware Version

Table 5-3. Firmware Version

Address	b7	b6	b5	b4	b3	b2	b1	b0
1	FIRMWARE VERSION							

FIRMWARE VERSION: this shows the 8-bit firmware version 1.5 (0x15).

5.4 Address 2: Detection Status

Table 5-4. Detection Status

Address	b7	b6	b5	b4	b3	b2	b1	b0
2	CALIBRATE	OVERFLOW	–	–	–	–	–	TOUCH

CALIBRATE: This bit is set during a calibration sequence.

OVERFLOW: This bit is set if the time to acquire all key signals exceeds 8 ms.

TOUCH: This bit is set if any keys are in detect.

5.5 Address 3: Key Status

Table 5-5. Key Status

Address	b7	b6	b5	b4	b3	b2	b1	b0
3	Reserved	KEY6	KEY5	KEY4	KEY3	KEY2	KEY1	KEY0

KEY0 – 6: bits 0 to 6 indicate which keys are in detection, if any. Touched keys report as 1, untouched or disabled keys report as 0.

5.6 Address 4 – 17: Key Signal

Table 5-6. Key Signal

Address	b7	b6	b5	b4	b3	b2	b1	b0
4	MSByte OF KEY SIGNAL FOR KEY 0							
5	LSByte OF KEY SIGNAL FOR KEY 0							
6 – 17	MSByte/LSByte OF KEY SIGNAL FOR KEYS 1 – 6							

KEY SIGNAL: addresses 4 – 17 allow key signals to be read for each key, starting with key 0. There are two bytes of data for each key. These are the key's 16-bit key signals which are accessed as two 8-bit bytes, stored MSByte first. These addresses are read-only.

5.7 Address 18 – 31: Reference Data

Table 5-7. Reference Data

Address	b7	b6	b5	b4	b3	b2	b1	b0
18	MSByte OF REFERENCE DATA FOR KEY 0							
19	LSByte OF REFERENCE DATA FOR KEY 0							
20 – 31	MSByte/LSByte OF REFERENCE DATA FOR KEYS 1 – 6							

REFERENCE DATA: addresses 18 – 31 allow reference data to be read for each key, starting with key 0. There are two bytes of data for each key. These are the key's 16-bit reference data which is accessed as two 8-bit bytes, stored MSByte first. These addresses are read-only.

5.8 Address 32 – 38: Negative Threshold (NTHR)

Table 5-8. NTHR

Address	b7	b6	b5	b4	b3	b2	b1	b0
32 – 38	NEGATIVE THRESHOLD FOR KEYS 0 – 6							

NTHR Keys 0 – 6: these 8-bit values set the threshold value for each key to register a detection.

Default: 20 counts

Note: Do not use a setting of 0 as this causes a key to go into detection when its signal is equal to its reference.

5.9 Address 39 – 45: Averaging Factor/Adjacent Key Suppression (AVE/AKS)

Table 5-9. AVE/AKS

Address	b7	b6	b5	b4	b3	b2	b1	b0
39 – 45	AVE5	AVE4	AVE3	AVE2	AVE1	AVE0	AKS1	AKS0

AVE 0 – 5: The Averaging Factor (AVE) is the number of pulses which are added together and averaged to get the final signal value for that channel.

For example, if AVE = 8 then 8 ADC samples are taken and added together. The result is divided by the original number of pulses (8). If sixteen pulses are used then the result is divided by sixteen.

This provides a better signal-to-noise ratio but requires longer acquire times. Values for AVE are restricted internally to 1, 2, 4, 8, 16 or 32.

Default: 8 (In standalone mode key 0 is 16)

AKS 0 – 1: these bits control which keys are included in an AKS group. There can be up to three groups, each containing any number of keys (up to the maximum allowed for the mode).

Each key can have a value between 0 and 3, which assigns it to an AKS group of that number. A key may only go into detect when it has the largest signal change of any key in its group. A value of 0 means the key is not in any AKS group.

Default: 0x01

5.10 Address 46 – 52: Detection Integrator (DI)

Table 5-10. Detection Integrator

Address	b7	b6	b5	b4	b3	b2	b1	b0
46 – 52	DETECTION INTEGRATOR							

DETECTION INTEGRATOR: addresses 46 – 52 allow the DI level to be set for each key. This 8-bit value controls the number of consecutive measurements that must be confirmed as having passed the key threshold before that key is registered as being in detect. The minimum value for the DI filter is 2. Settings of 0 and 1 for the DI also default to 2 because a minimum of two consecutive measurements must be confirmed.

Default: 4

5.11 Address 53: FastOutDI/Max Cal/Guard Channel

Table 5-11. Max Cal/Guard Channel

Address	b7	b6	b5	b4	b3	b2	b1	b0
53	–		FO	MAX CAL	GUARD CHANNEL			

FO: Fast Out DI – when bit 5 is set then a key filters out with an integrator of 4. Could have a DI in of 100 but filter out with DI of 4 (global setting for all keys).

MAX CAL: if this bit is clear then all keys recalibrate after a Max On Duration timeout, otherwise only the key with the incorrect timing gets recalibrated.

GUARD CHANNEL: bits 0 – 3 are used to set a key as the guard channel (which gets priority filtering). Valid values are 0 – 6, with any larger value disabling the guard key feature.

5.12 Address 54: Low Power (LP) Mode

Table 5-12. LP Mode

Address	b7	b6	b5	b4	b3	b2	b1	b0
54	LOW POWER MODE							

LP MODE: this 8-bit value determines the number of 8 ms intervals between key measurements. Longer intervals between measurements yield a lower power consumption but at the expense of a slower response to touch.

Setting	Time
0	8 ms
1	8 ms
2	16 ms
3	24 ms
4	32 ms
...	...
254	2.032s
255	2.040s

Default: 2 (16 ms between key acquisitions)

5.13 Address 55: Max On Duration

Table 5-13. Max Time On

Address	b7	b6	b5	b4	b3	b2	b1	b0
55	MAX ON DURATION							

MAX ON DURATION: this is a 8-bit value which determines how long any key can be in touch before it recalibrates itself.

A value of 0 turns Max On Duration off.

Setting	Time
0	Off
1	160 ms
2	320 ms
3	480 ms
4	640 ms
255	40.8s

Default: 180 (160 ms × 180 = 28.8s)

5.14 Address 56: Calibrate

Table 5-14. Calibrate

Address	b7	b6	b5	b4	b3	b2	b1	b0
56	Writing a nonzero value forces a calibration							

Writing any nonzero value into this address triggers the device to start a calibration cycle. The CALIBRATE flag in the detection status register is set when the calibration begins and clears when the calibration has finished.

5.15 Address 57: $\overline{\text{RESET}}$

Table 5-15. $\overline{\text{RESET}}$

Address	b7	b6	b5	b4	b3	b2	b1	b0
57	Writing a nonzero value forces a reset							

Writing any nonzero value to this address triggers the device to reset.

6. Specifications

6.1 Absolute Maximum Specifications

Vdd	–0.5 to +6 V
Max continuous pin current, any control or drive pin	±10 mA
Short circuit duration to ground, any pin	infinite
Short circuit duration to Vdd, any pin	infinite
Voltage forced onto any pin	–0.5 V to (Vdd + 0.5) V

CAUTION: Stresses beyond those listed under *Absolute Maximum Specifications* may cause permanent damage to the device. This is a stress rating only and functional operation of the device at these or other conditions beyond those indicated in the operational sections of this specification is not implied. Exposure to absolute maximum specification conditions for extended periods may affect device reliability.

6.2 Recommended Operating Conditions

Operating temperature	–40°C to +85°C
Storage temperature	–55°C to +125°C
Vdd	+1.8 V to 5.5 V
Supply ripple+noise	±25 mV
Cx load capacitance per key	1 to 30 pF

6.3 DC Specifications

Vdd = 3.3 V, Cs = 10 nF, load = 5 pF, 32 ms default sleep, Ta = recommended range, unless otherwise noted

Parameter	Description	Minimum	Typical	Maximum	Units	Notes
Vil	Low input logic level	–	–	0.2 × Vdd	V	
Vih	High input logic level	0.7 × Vdd	–	Vdd + 0.5	V	
Vol	Low output voltage	–	–	0.6	V	
Voh	High output voltage	Vdd – 0.7V	–	–	V	
Iil	Input leakage current	–	–	±1	µA	

6.4 Power Consumption Measurements

$C_x = 5 \text{ pF}$, $R_s = 4.7 \text{ k}\Omega$

LP Mode	I _{dd} (μA) at V _{dd} =		
	5 V	3.3 V	1.8 V
0 (8 ms)	1744	906	442
1 (16 ms)	1375	615	305
2 (24 ms)	1263	525	261
4 (32 ms)	1168	486	234
5 (40 ms)	1119	445	221
6 (48 ms)	1089	434	211

6.5 Timing Specifications

Parameter	Description	Minimum	Typical	Maximum	Units	Notes
T _R	Response time	DI setting × 8 ms	–	LP mode + (DI setting × 8 ms)	ms	Under host control
F _{QT}	Sample frequency	162	180	198	kHz	Modulated spread-spectrum (chirp)
T _D	Power-up delay to operate/calibration time	–	<230	–	ms	Can be longer if burst is very long.
F _{I2C}	I ² C clock rate	–	–	400	kHz	–
F _m	Burst modulation, percentage	–	±8	–	%	–
	RESET pulse width	5	–	–	μs	–

6.6 Mechanical Dimensions

6.7 AT42QT1070-SSU – 14-pin SOIC

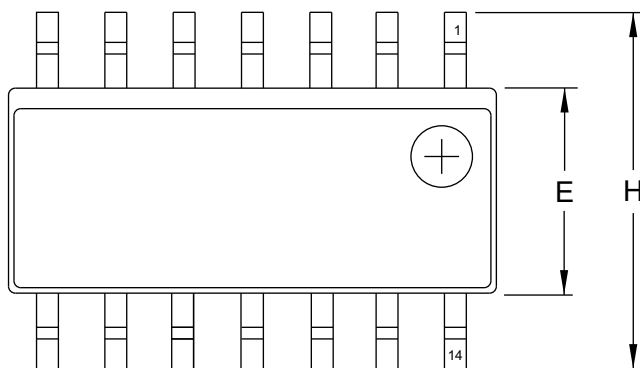

Top View

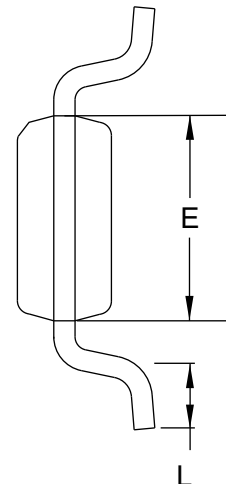

End View

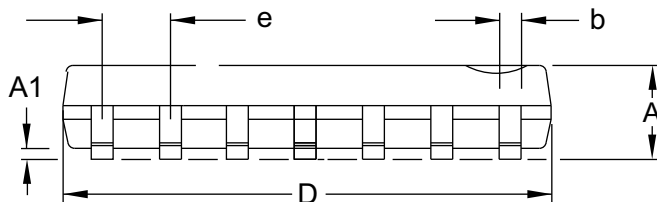

Side View

COMMON DIMENSIONS
(Unit of Measure = inches)

SYMBOL	MIN	NOM	MAX	NOTE
A	0.0532	–	0.0688	
A1	0.0040	–	0.0098	
b	0.0130	–	0.0200	5
D	0.3367	–	0.3444	2
E	0.1497	–	0.1574	3
H	0.2284	–	0.2440	
L	0.0160	–	0.0500	4
e	0.050 BSC			

- Notes:
1. This drawing is for general information only; refer to JEDEC Drawing MS-012, Variation AB for additional information.
 2. Dimension D does not include mold Flash, protrusions or gate burrs. Mold Flash, protrusion and gate burrs shall not exceed 0.15 mm (0.006") per side.
 3. Dimension E does not include inter-lead Flash or protrusion. Inter-lead flash and protrusions shall not exceed 0.25 mm (0.010") per side.
 4. L is the length of the terminal for soldering to a substrate.
 5. The lead width B, as measured 0.36 mm (0.014") or greater above the seating plane, shall not exceed a maximum value of 0.61 mm (0.024") per side.

1/15/13

Atmel

Package Drawing Contact:
packagedrawings@atmel.com

TITLE

14S1, 14-lead, 0.150" Wide Body, Plastic Gull
Wing Small Outline Package (SOIC)

GPC

SVQ

DRAWING NO.

14S1

REV.

B

6.8 AT42QT1070-MMH – 20-pin 3 x 3 mm VQFN

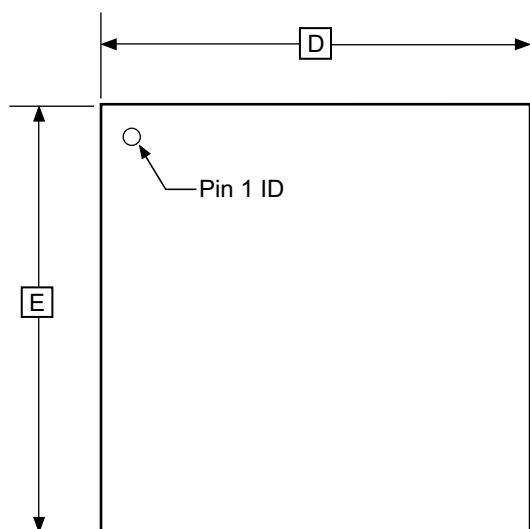

TOP VIEW

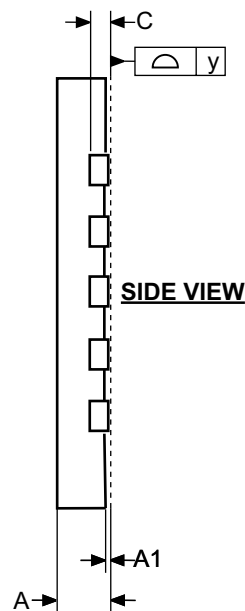

SIDE VIEW

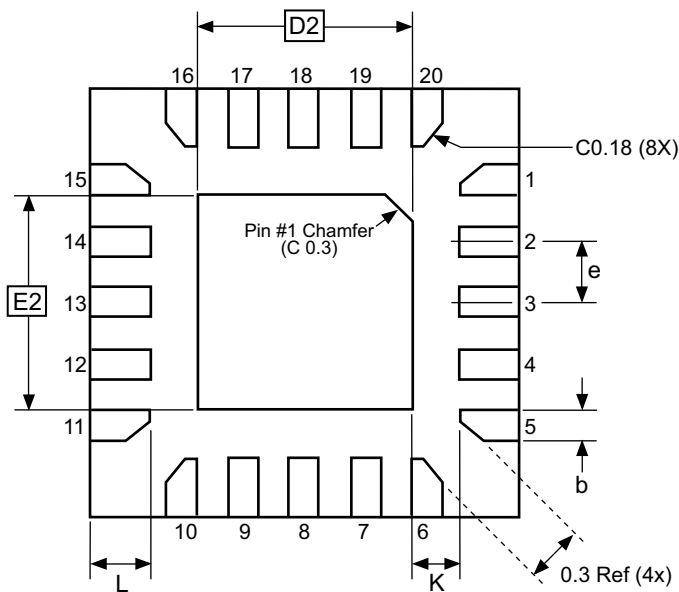

BOTTOM VIEW

COMMON DIMENSIONS
(Unit of Measure = mm)

SYMBOL	MIN	NOM	MAX	NOTE
A	0.75	0.80	0.85	
A1	0.00	0.02	0.05	
b	0.17	0.22	0.27	
C	0.152			
D	2.90	3.00	3.10	
D2	1.40	1.55	1.70	
E	2.90	3.00	3.10	
E2	1.40	1.55	1.70	
e	-	0.45	-	
L	0.35	0.40	0.45	
K	0.20	-	-	
y	0.00	-	0.08	

1/15/13

Atmel

Package Drawing Contact:
packagedrawings@atmel.com

TITLE

20M2, 20-pad, 3 x 3 x 0.85 mm Body, Lead Pitch 0.45 mm,
1.55 x 1.55 mm Exposed Pad, Thermally Enhanced
Plastic Very Thin Quad Flat No Lead Package (VQFN)

GPC

ZFC

DRAWING NO.

20M2

REV.

C

6.9 Marking

6.9.1 AT42QT1070-SSU – 14-pin SOIC

Either part marking can be used.

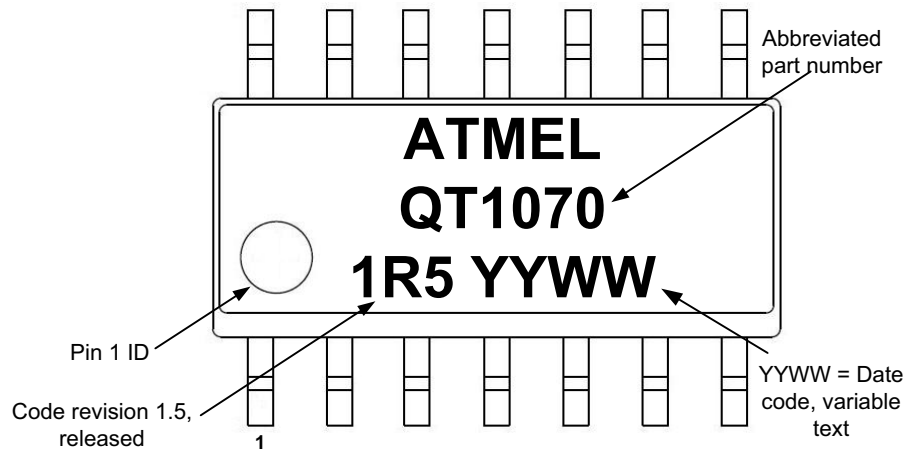
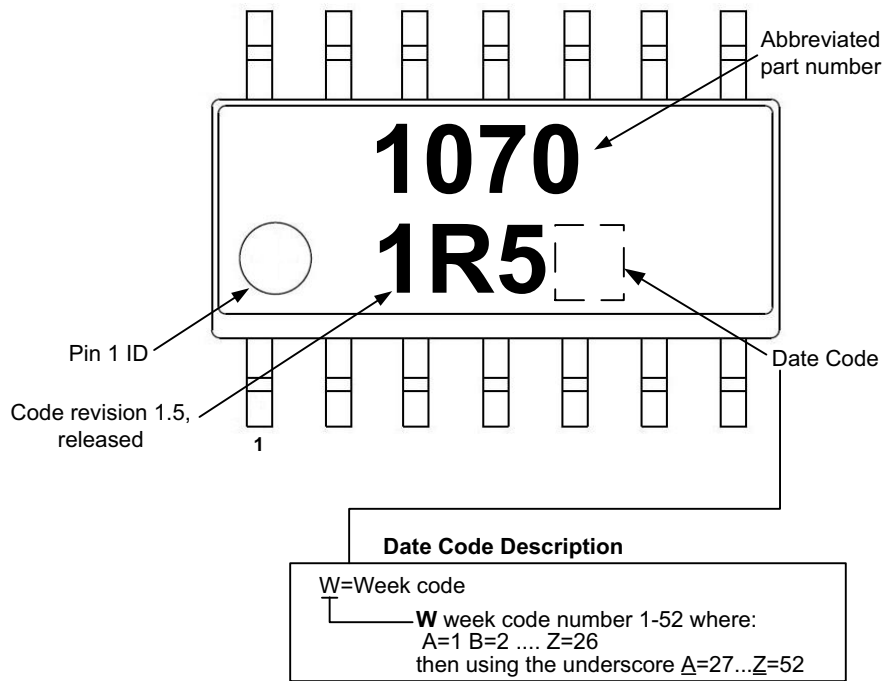

6.9.2 AT42QT1070-MMH – 20-pin 3 × 3 mm VQFN

Either part marking can be used.

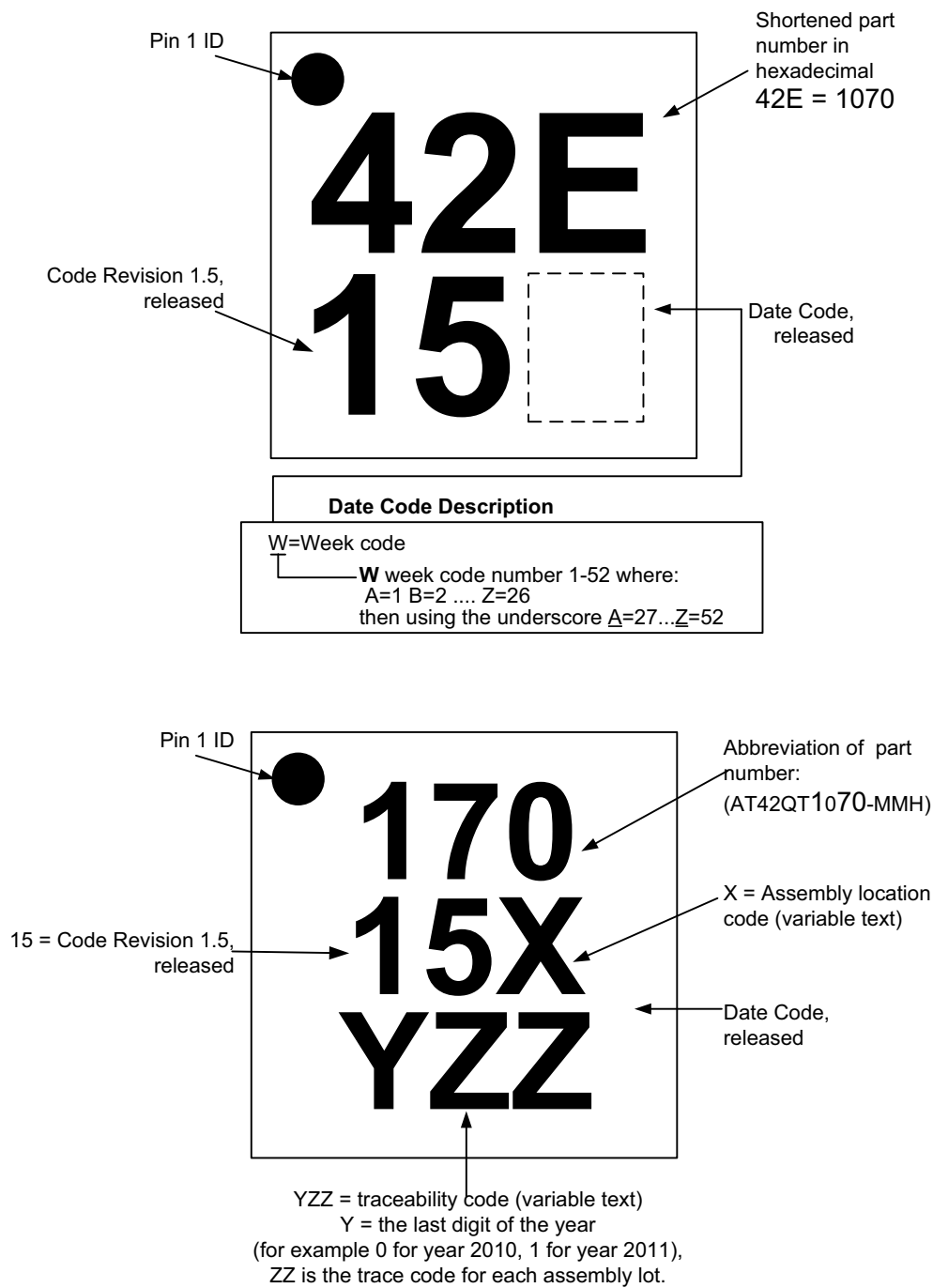

6.10 Part Number

Part Number	Description
AT42QT1070-SSU	14-pin SOIC RoHS compliant IC
AT42QT1070-MMH	20-pin 3 x 3 mm VQFN RoHS compliant IC

6.11 Moisture Sensitivity Level (MSL)

MSL Rating	Peak Body Temperature	Specifications
MSL3	260°C	IPC/JEDEC J-STD-020

Appendix A. I²C Operation

The device communicates with the host over an I²C bus. The following sections give an overview of the bus; more detailed information is available from www.i2c-bus.org. Devices are connected to the I²C bus as shown in Figure A-1. Both bus lines are connected to V_{dd} via pull-up resistors. The bus drivers of all I²C devices must be open-drain type. This implements a wired AND function that allows any and all devices to drive the bus, one at a time. A low level on the bus is generated when a device outputs a zero.

Figure A-1. I²C Interface Bus

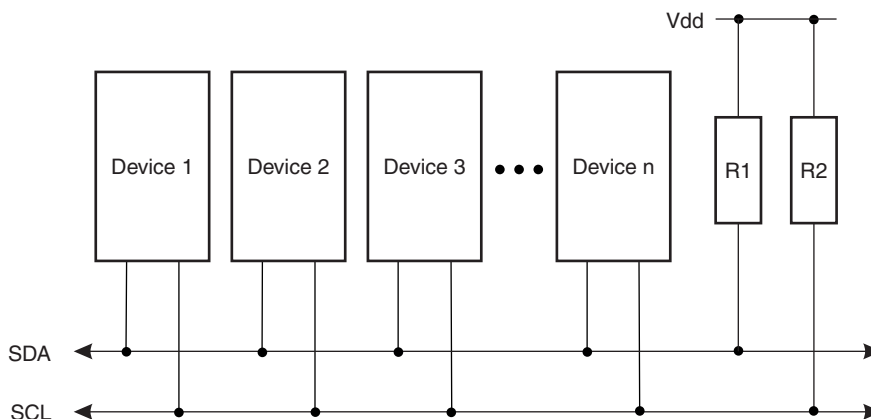

A.1 Transferring Data Bits

Each data bit transferred on the bus is accompanied by a pulse on the clock line. The level of the data line must be stable when the clock line is high; the only exception to this rule is for generating START and STOP conditions.

Figure A-2. Data Transfer

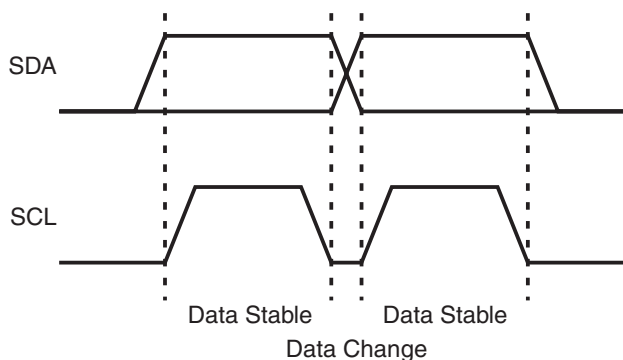

A.2 START and STOP Conditions

The host initiates and terminates a data transmission. The transmission is initiated when the host issues a START condition on the bus, and is terminated when the host issues a STOP condition. Between the START and STOP conditions, the bus is considered busy. As shown in Figure A-3, START and STOP conditions are signaled by changing the level of the SDA line when the SCL line is high.

Figure A-3. START and STOP Conditions

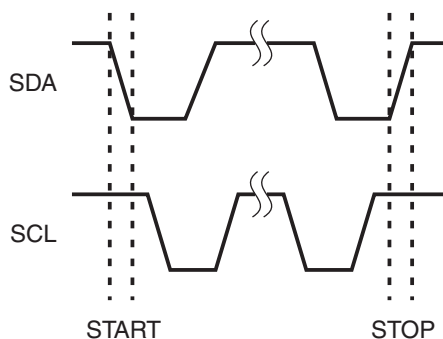

A.3 Address Byte Format

All address bytes are 9 bits long, consisting of 7 address bits, one READ/WRITE control bit and an acknowledge bit. If the READ/WRITE bit is set, a read operation is performed, otherwise a write operation is performed. When the device recognizes that it is being addressed, it will acknowledge by pulling SDA low in the ninth SCL (ACK) cycle. An address byte consisting of a slave address and a READ or a WRITE bit is called SLA+R or SLA+W, respectively.

The most significant bit of the address byte is transmitted first. The address sent by the host must be consistent with that selected with the option jumpers.

Figure A-4. Address Byte Format

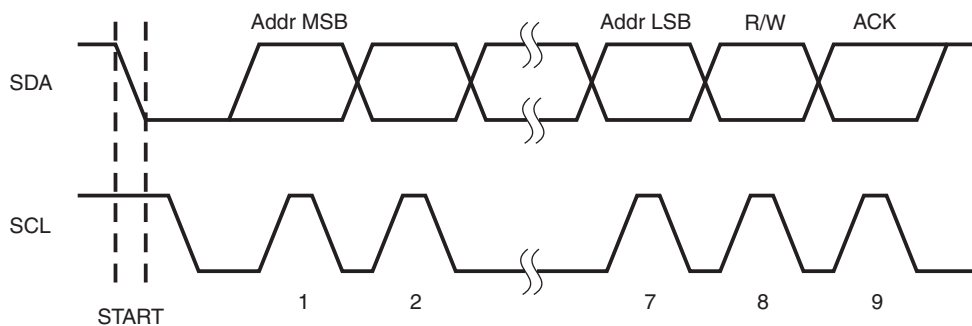

A.4 Data Byte Format

All data bytes are 9 bits long, consisting of 8 data bits and an acknowledge bit. During a data transfer, the host generates the clock and the START and STOP conditions, while the receiver is responsible for acknowledging the reception. An acknowledge (ACK) is signaled by the receiver pulling the SDA line low during the ninth SCL cycle. If the receiver leaves the SDA line high, a NACK is signaled.

Figure A-5. Data Byte Format

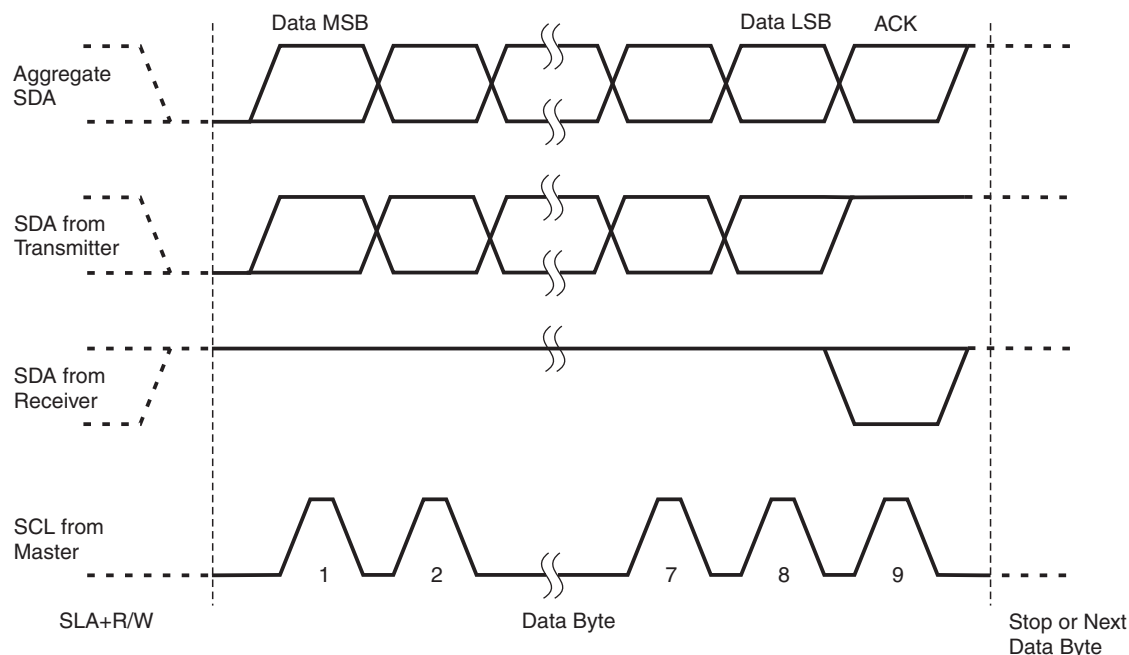

A.5 Combining Address and Data Bytes into a Transmission

A transmission consists of a START condition, an SLA+R/W, one or more data bytes and a STOP condition. The wired *ANDing* of the SCL line is used to implement handshaking between the host and the device. The device extends the SCL low period by pulling the SCL line low whenever it needs extra time for processing between the data transmissions.

Note: Each write or read cycle must end with a stop condition. The device may not respond correctly if a cycle is terminated by a new start condition.

Figure A-6 shows a typical data transmission. Note that several data bytes can be transmitted between the SLA+R/W and the STOP.

Figure A-6. Byte Transmission

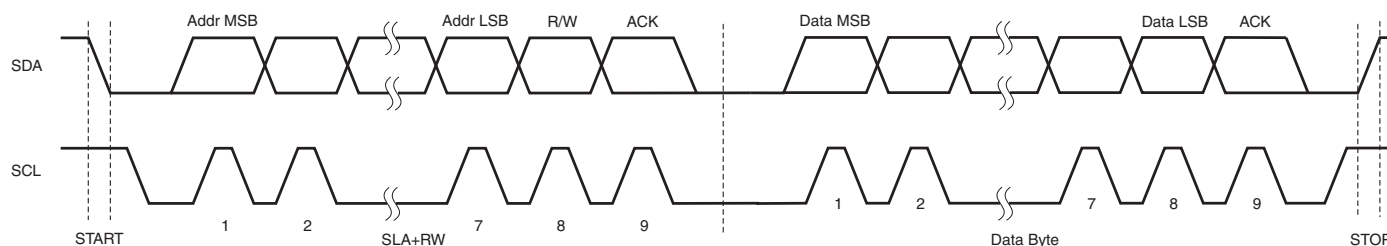

Associated Documents

- QTAN0062 – *QTouch and QMatrix Sensitivity Tuning for Keys, Slider and Wheels*
- *Touch Sensors Design Guide*

Revision History

Revision Number	History
Revision A – October 2010	Initial release of document for code revision 1.5
Revision B – November 2012	General updates
Revision C – May 2013	Applied new template

Notes



Enabling Unlimited Possibilities®

Atmel Corporation

1600 Technology Drive
San Jose, CA 95110
USA

Tel: (+1) (408) 441-0311

Fax: (+1) (408) 487-2600

www.atmel.com

Atmel Asia Limited

Unit 01-5 & 16, 19F
BEA Tower, Millennium City 5

418 Kwun Tong Roa

Kwun Tong, Kowloon

HONG KONG

Tel: (+852) 2245-6100

Fax: (+852) 2722-1369

Atmel München GmbH

Business Campus

Parkring 4

D-85748 Garching bei München

GERMANY

Tel: (+49) 89-31970-0

Fax: (+49) 89-3194621

Atmel Japan G.K.

16F Shin-Osaki Kangyo Bldg

1-6-4 Osaki, Shinagawa-ku

Tokyo 141-0032

JAPAN

Tel: (+81) (3) 6417-0300

Fax: (+81) (3) 6417-0370

© 2013 Atmel Corporation. All rights reserved. / Rev.: 9596C-AT42-05/2013

Atmel®, Atmel logo and combinations thereof, Adjacent Key Suppression®, AKS®, QTouch®, and others are registered trademarks or trademarks of Atmel Corporation or its subsidiaries. Other terms and product names may be registered trademarks or trademarks of others.

Disclaimer: The information in this document is provided in connection with Atmel products. No license, express or implied, by estoppel or otherwise, to any intellectual property right is granted by this document or in connection with the sale of Atmel products. EXCEPT AS SET FORTH IN THE ATMEL TERMS AND CONDITIONS OF SALES LOCATED ON THE ATMEL WEBSITE, ATMEL ASSUMES NO LIABILITY WHATSOEVER AND DISCLAIMS ANY EXPRESS, IMPLIED OR STATUTORY WARRANTY RELATING TO ITS PRODUCTS INCLUDING, BUT NOT LIMITED TO, THE IMPLIED WARRANTY OF MERCHANTABILITY, FITNESS FOR A PARTICULAR PURPOSE, OR NON-INFRINGEMENT. IN NO EVENT SHALL ATMEL BE LIABLE FOR ANY DIRECT, INDIRECT, CONSEQUENTIAL, PUNITIVE, SPECIAL OR INCIDENTAL DAMAGES (INCLUDING, WITHOUT LIMITATION, DAMAGES FOR LOSS AND PROFITS, BUSINESS INTERRUPTION, OR LOSS OF INFORMATION) ARISING OUT OF THE USE OR INABILITY TO USE THIS DOCUMENT, EVEN IF ATMEL HAS BEEN ADVISED OF THE POSSIBILITY OF SUCH DAMAGES. Atmel makes no representations or warranties with respect to the accuracy or completeness of the contents of this document and reserves the right to make changes to specifications and products descriptions at any time without notice. Atmel does not make any commitment to update the information contained herein. Unless specifically provided otherwise, Atmel products are not suitable for, and shall not be used in, automotive applications. Atmel products are not intended, authorized, or warranted for use as components in applications intended to support or sustain life.

Mouser Electronics

Authorized Distributor

Click to View Pricing, Inventory, Delivery & Lifecycle Information:

[Microchip:](#)

[AT42QT1070-MMH](#) [AT42QT1070-SSU](#) [AT42QT1070-MMHR](#) [AT42QT1070-SSUR](#)

Компания «Life Electronics» занимается поставками электронных компонентов импортного и отечественного производства от производителей и со складов крупных дистрибьюторов Европы, Америки и Азии.

С конца 2013 года компания активно расширяет линейку поставок компонентов по направлению коаксиальный кабель, кварцевые генераторы и конденсаторы (керамические, пленочные, электролитические), за счёт заключения дистрибьюторских договоров

Мы предлагаем:

- Конкурентоспособные цены и скидки постоянным клиентам.
- Специальные условия для постоянных клиентов.
- Подбор аналогов.
- Поставку компонентов в любых объемах, удовлетворяющих вашим потребностям.
- Приемлемые сроки поставки, возможна ускоренная поставка.
- Доставку товара в любую точку России и стран СНГ.
- Комплексную поставку.
- Работу по проектам и поставку образцов.
- Формирование склада под заказчика.
- Сертификаты соответствия на поставляемую продукцию (по желанию клиента).
- Тестирование поставляемой продукции.
- Поставку компонентов, требующих военную и космическую приемку.
- Входной контроль качества.
- Наличие сертификата ISO.

В составе нашей компании организован Конструкторский отдел, призванный помогать разработчикам, и инженерам.

Конструкторский отдел помогает осуществить:

- Регистрацию проекта у производителя компонентов.
- Техническую поддержку проекта.
- Защиту от снятия компонента с производства.
- Оценку стоимости проекта по компонентам.
- Изготовление тестовой платы монтаж и пусконаладочные работы.



Тел: +7 (812) 336 43 04 (многоканальный)

Email: org@lifeelectronics.ru