



## SERIES: EMC-30 | DESCRIPTION: AC POWER LINE FILTER

### FEATURES

- 30 dB AC-line noise filtering (150 kHz ~ 1 GHz)
- ensures surge compliance to IEC/EN61000-4-5 standard  
±4 kV (2Ω) / ±6 kV (12Ω)
- reduces emissions to help comply with CISPR22 / EN 55022 Class B
- accepts up to 1.5 A (rms) of nominal input current
- wide input voltage range (85~305 Vac)
- wide operating temperature range (-40 to +85 °C)
- options for board-mount, chassis-mount, or DIN-Rail mounting



### SPECIFICATIONS

parameter	conditions/description	min	typ	max	units
input voltage		85		305	Vac
input current				1.5	A
noise attenuation	at 150 kHz ~ 1 GHz		30		dB
isolation voltage	L/PE, N/PE at 1 minute and leakage current 5 mA max		2,000		Vac
RoHS	yes				
operating temperature		-40		85	°C
storage temperature		-55		125	°C
storage humidity	non-condensing			95	%
case temperature rise	at 220 Vac, 0.5 A			5	°C
	at 220 Vac, 1.0 A			20	°C
	at 220 Vac, 1.5 A			30	°C

Notes: 1. All specifications are measured at Ta=25°C, humidity < 75%, nominal unless otherwise specified.

### PART NUMBER KEY

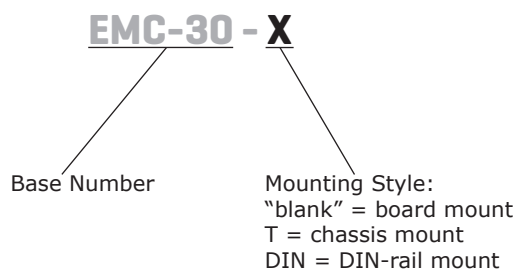

## SOLDERABILITY<sup>2</sup>

parameter	conditions/description	min	typ	max	units
hand soldering	for 3~5 seconds	350	360	370	°C
wave soldering	see wave soldering profile			260	°C

Note: 2. For board mount models only.

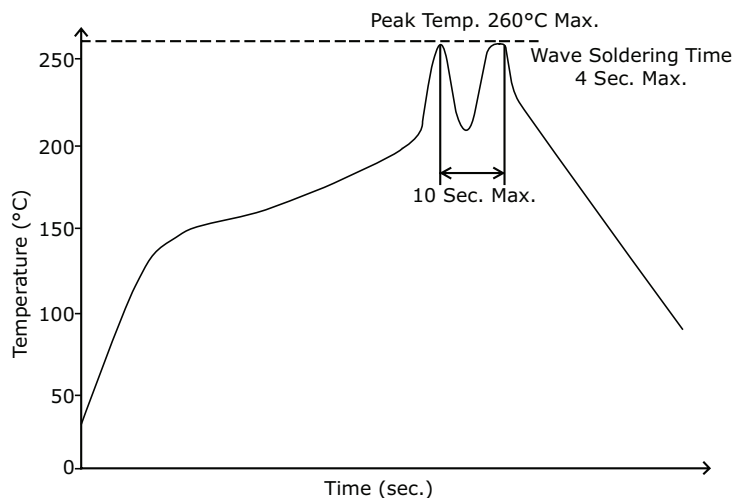

## MECHANICAL

parameter	conditions/description	min	typ	max	units
dimensions	board mount: 53.80 x 28.80 x 19.00 [2.118 x 1.134 x 0.748 inch] chassis mount: 76.00 x 31.50 x 27.80 [2.992 x 1.240 x 1.094 inch] DIN-Rail mount: 76.00 x 31.50 x 32.40 [2.992 x 1.240 x 1.276 inch]				mm
case material	black flame-retardant heat-proof epoxy resin (UL94V-0)				
weight	board mount chassis mount DIN-rail mount		50 70 90		g

## MECHANICAL DRAWING (BOARD MOUNT)

units: mm [inch]  
tolerance: ±0.50[±0.020]  
pin diameter tolerance: ±0.10[±0.004]

PIN CONNECTIONS	
PIN	Function
1	GND
2	IN(N)
3	IN(L)
4	OUT(L)
5	OUT(N)

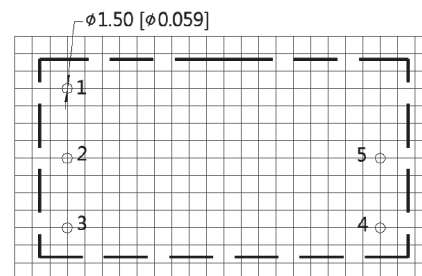
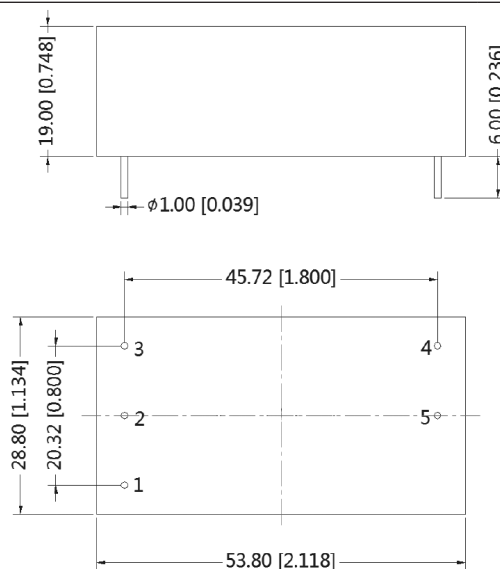

Note : Grid 2.54\*2.54mm

Recommended PCB Layout  
Top View

## MECHANICAL DRAWING (CHASSIS MOUNT)

units: mm [inch]  
tolerance:  $\pm 0.50[\pm 0.020]$

wire range: 24~12 AWG

PIN CONNECTIONS	
PIN	Function
1	GND
2	IN(N)
3	IN(L)
4	OUT(L)
5	OUT(N)

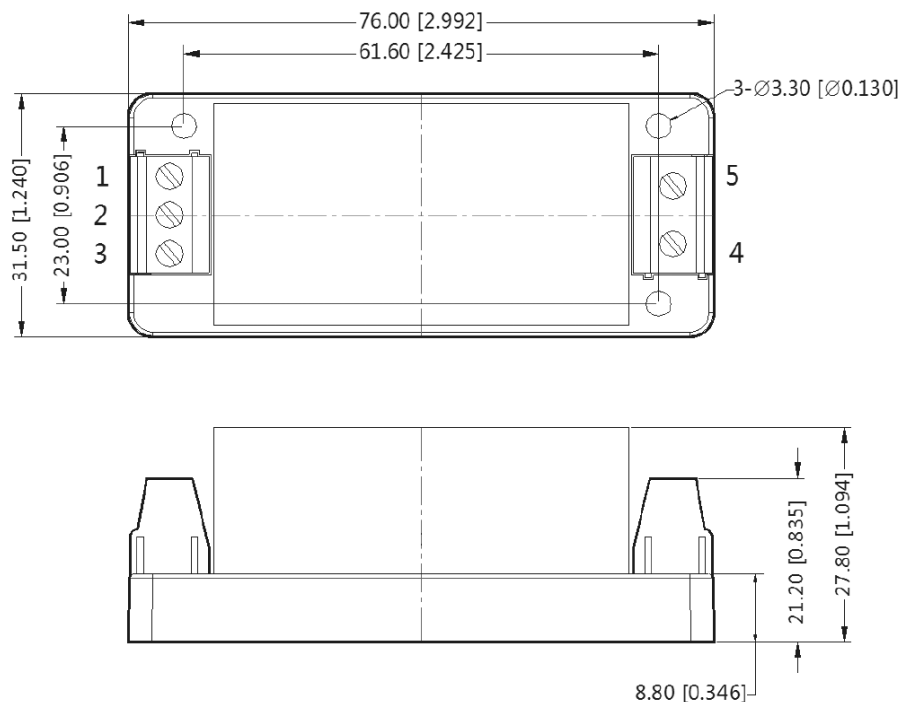

## MECHANICAL DRAWING (DIN-RAIL MOUNT)

units: mm [inch]  
tolerance:  $\pm 0.50[\pm 0.020]$

installed on DIN rail TS35  
wire range: 24~12 AWG

PIN CONNECTIONS	
PIN	Function
1	GND
2	IN(N)
3	IN(L)
4	OUT(L)
5	OUT(N)

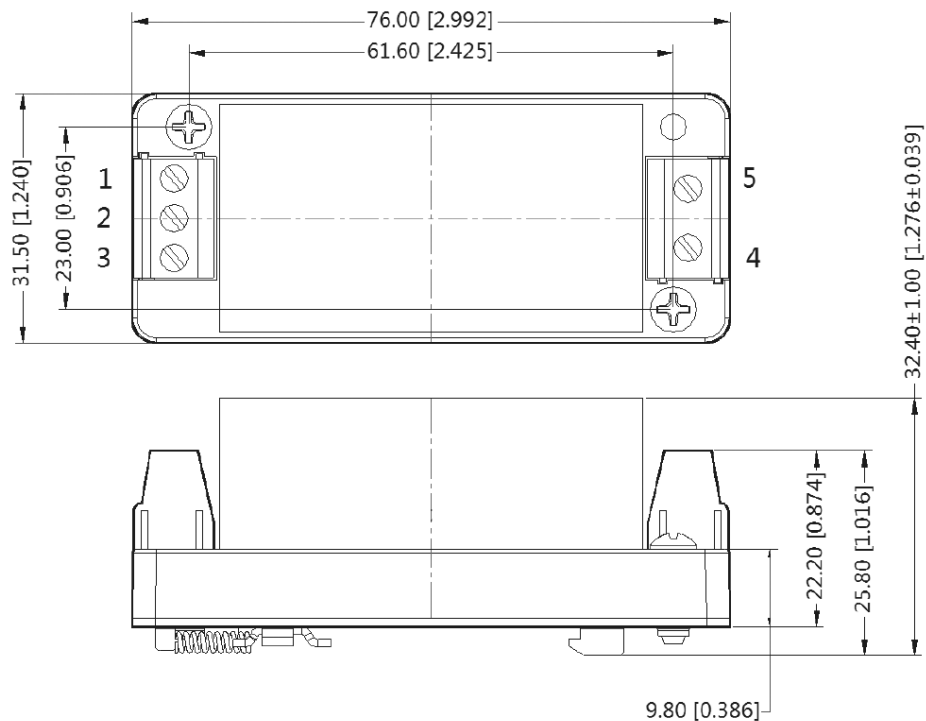

## EMC SPECIFICATIONS

Put the EMC-30 on the input of the AC-DC module to meet surge level IEC/EN 61000-4-5  $\pm 4$  kV ( $2 \Omega$  internal resistance),  $\pm 6$  kV ( $12 \Omega$  internal resistance), and help to meet EN 55022 Class B.

Figure 1  
Internal Circuit

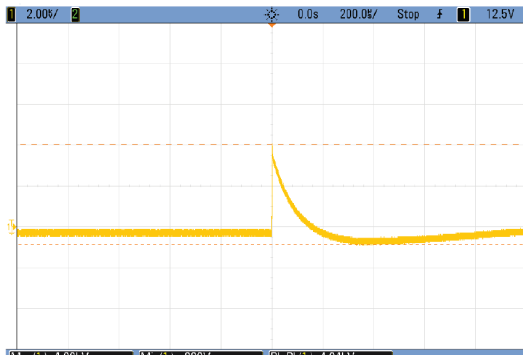
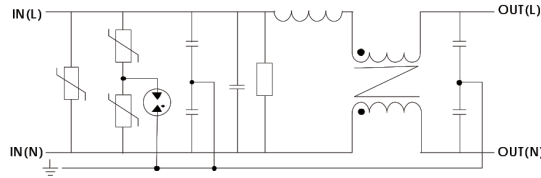

Input voltage waveform (Differential mode 4.06KV)



Output voltage waveform (Differential mode 0.90KV)

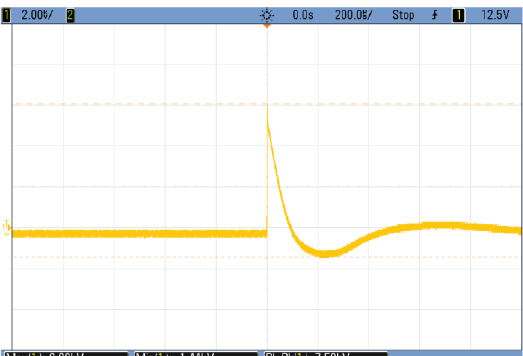

Input voltage waveform (Common mode 6.06KV)

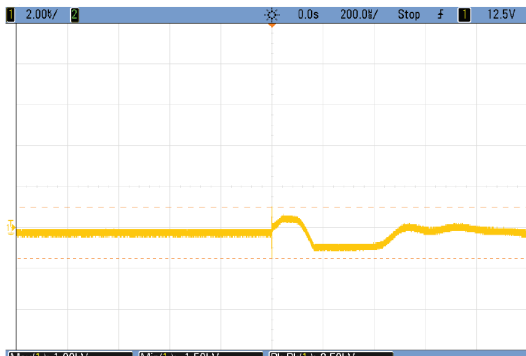

Output voltage waveform(Common mode 1.00KV)

## APPLICATION CIRCUIT

Figure 2  
Application Circuit

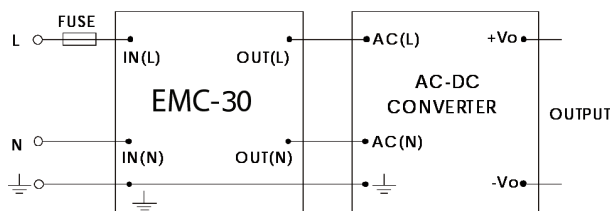

## REVISION HISTORY

---

rev.	description	date
1.0	initial release	10/26/2018

The revision history provided is for informational purposes only and is believed to be accurate.



**Headquarters**  
20050 SW 112th Ave.  
Tualatin, OR 97062  
**800.275.4899**

Fax 503.612.2383  
**cui.com**  
techsupport@cui.com

CUI offers a two (2) year limited warranty. Complete warranty information is listed on our website.

CUI reserves the right to make changes to the product at any time without notice. Information provided by CUI is believed to be accurate and reliable. However, no responsibility is assumed by CUI for its use, nor for any infringements of patents or other rights of third parties which may result from its use.

CUI products are not authorized or warranted for use as critical components in equipment that requires an extremely high level of reliability. A critical component is any component of a life support device or system whose failure to perform can be reasonably expected to cause the failure of the life support device or system, or to affect its safety or effectiveness.

Компания «Life Electronics» занимается поставками электронных компонентов импортного и отечественного производства от производителей и со складов крупных дистрибьюторов Европы, Америки и Азии.

С конца 2013 года компания активно расширяет линейку поставок компонентов по направлению коаксиальный кабель, кварцевые генераторы и конденсаторы (керамические, пленочные, электролитические), за счёт заключения дистрибьюторских договоров

Мы предлагаем:

- Конкуренеспособные цены и скидки постоянным клиентам.
- Специальные условия для постоянных клиентов.
- Подбор аналогов.
- Поставку компонентов в любых объемах, удовлетворяющих вашим потребностям.
- Приемлемые сроки поставки, возможна ускоренная поставка.
- Доставку товара в любую точку России и стран СНГ.
- Комплексную поставку.
- Работу по проектам и поставку образцов.
- Формирование склада под заказчика.
- Сертификаты соответствия на поставляемую продукцию (по желанию клиента).
- Тестирование поставляемой продукции.
- Поставку компонентов, требующих военную и космическую приемку.
- Входной контроль качества.
- Наличие сертификата ISO.

В составе нашей компании организован Конструкторский отдел, призванный помогать разработчикам, и инженерам.

Конструкторский отдел помогает осуществить:

- Регистрацию проекта у производителя компонентов.
- Техническую поддержку проекта.
- Защиту от снятия компонента с производства.
- Оценку стоимости проекта по компонентам.
- Изготовление тестовой платы монтаж и пусконаладочные работы.



Тел: +7 (812) 336 43 04 (многоканальный)

Email: [org@lifeelectronics.ru](mailto:org@lifeelectronics.ru)