

SIGNAL LEVEL SENSOR SYSTEM

■ GENERAL DESCRIPTION

The **NJU7181** is a signal level sensor system IC. It sends a High flag to the microprocessor or other equipments whenever it detects the existence of the audio signal.

The **NJU7181** includes a delay circuit which allows the IC continue to hold the flag after the absence of the audio signal. This holding time can be adjusted with external capacitor.

Together with its adjustable Input Sensitivity (*by external resistor*) & its characteristic of low current consumption and low operating voltage, **NJU7181** is suitable for Eco-Design of Energy-using Products and for battery operated applications.

■ PACKAGE OUTLINE



NJU7181RB1
MSOP8 (TVSP8)



NJU7181KU1

■ FEATURES

- Operating Voltage 0.9 to 5.5V
- Low Operating Current 55µA typ.
- Delay circuit for long Recovery time
- Adjustable Recovery time by external capacitor
- Adjustable Input Sensitivity by external resistance
- C-MOS Technology
- Package Outline MSOP8 (TVSP8)*
ESON8
*MEET JEDEC MO-187-DA / THIN TYPE

■ APPLICATIONS

- Power Saving for battery operated devices
- Muting Application
- Memory saving for recording devices
- Half- duplex transmission application

■ BLOCK DIAGRAM

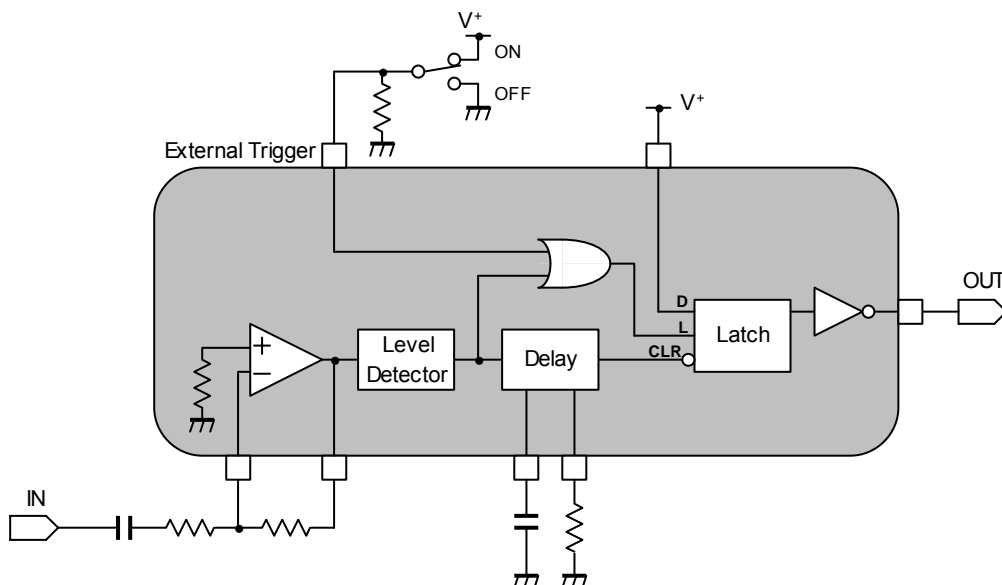

■ PIN CONFIGURATION

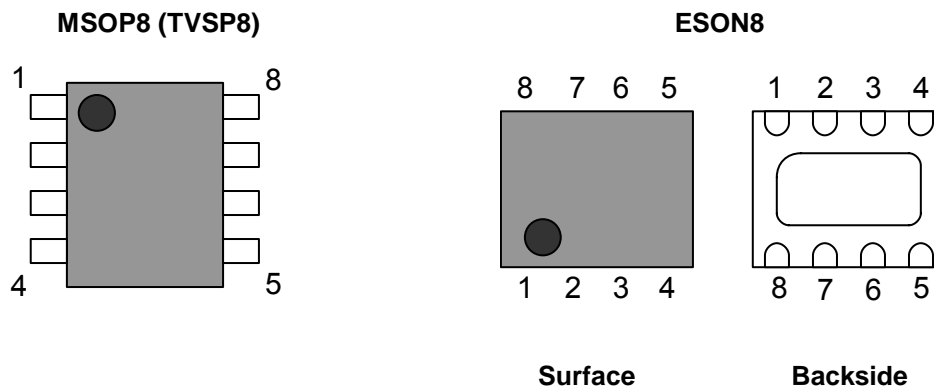

No.	Symbol	Function
1	IN	AC Input
2	AMP_OUT	Amplifier Output
3	TRIN	External Trigger Input
4	GND	Ground
5	CAP_D	Delay Time Capacitor
6	RES_D	Delay Time Resister
7	OUT	DC Output
8	V ⁺	Supply Voltage

■ ABSOLUTE MAXIMUM RATING (Ta=25°C)

PARAMETER	SYMBOL	RATING	UNIT
Supply Voltage	V ⁺	+7	V
Power Dissipation	P _D	MSOP8 (TVSP8): 470 (Note1) ESON8: 450	mW
Maximum Input Voltage	V _{IMAX}	0 ~ V ⁺ (Note2)	V
Operating Temperature Range	T _{opr}	-40 ~ +85	°C
Storage Temperature Range	T _{stg}	-40 ~ +125	°C

(Note1) EIA/JEDEC STANDARD Test board (76.2x114.3x1.6mm, 2layer, FR-4) mounting

(Note2) Don't put Input Voltage more than Power Supply Voltage.

■ ELECTRICAL CHARACTERISTICS

(Ta=25°C, V⁺=3V, R₁=10kΩ, R₂=100kΩ, R_d=220kΩ, C_d=10nF)

PARAMETER	SYMBOL	TEST CONDITION	MIN.	TYP.	MAX.	UNIT
Operating Voltage	V ⁺		0.9	-	5.5	V
Operating Current	I _{DD}	No signal, R _L =∞	-	55	100	μA
Input Sensitivity	V _{INS}	f=1kHz	-45	-41.5	-38	dBV
Delay Time 1	T _{delay1}		1.0	1.5	2.0	Sec
Delay Time 2	T _{delay2}	V ⁺ =0.9V	1.0	1.5	2.0	Sec
Delay Time 3	T _{delay3}	C _d =10μF	-	1,500	-	Sec

■ DC CHARACTERISTICS

DC Output Terminal (7pin)

(Ta=25°C)

PARAMETER	SYMBOL	TEST CONDITION	MIN.	TYP.	MAX.	UNIT
High Level Output Voltage	V _{OH}	I _{SOURCE} =1mA	V ⁺ -0.2	-	V ⁺	V
Low Level Output Voltage	V _{OL}	I _{SINK} =1mA	0	-	0.2	V

External Trigger Switch Terminal (3pin)

(Ta=25°C)

High Level Input Voltage	V _{IH}		V ⁺ -0.2	-	V ⁺	V
Low Level Input Voltage	V _{IL}		0	-	0.2	V

NJU7181

■ TEST CIRCUIT

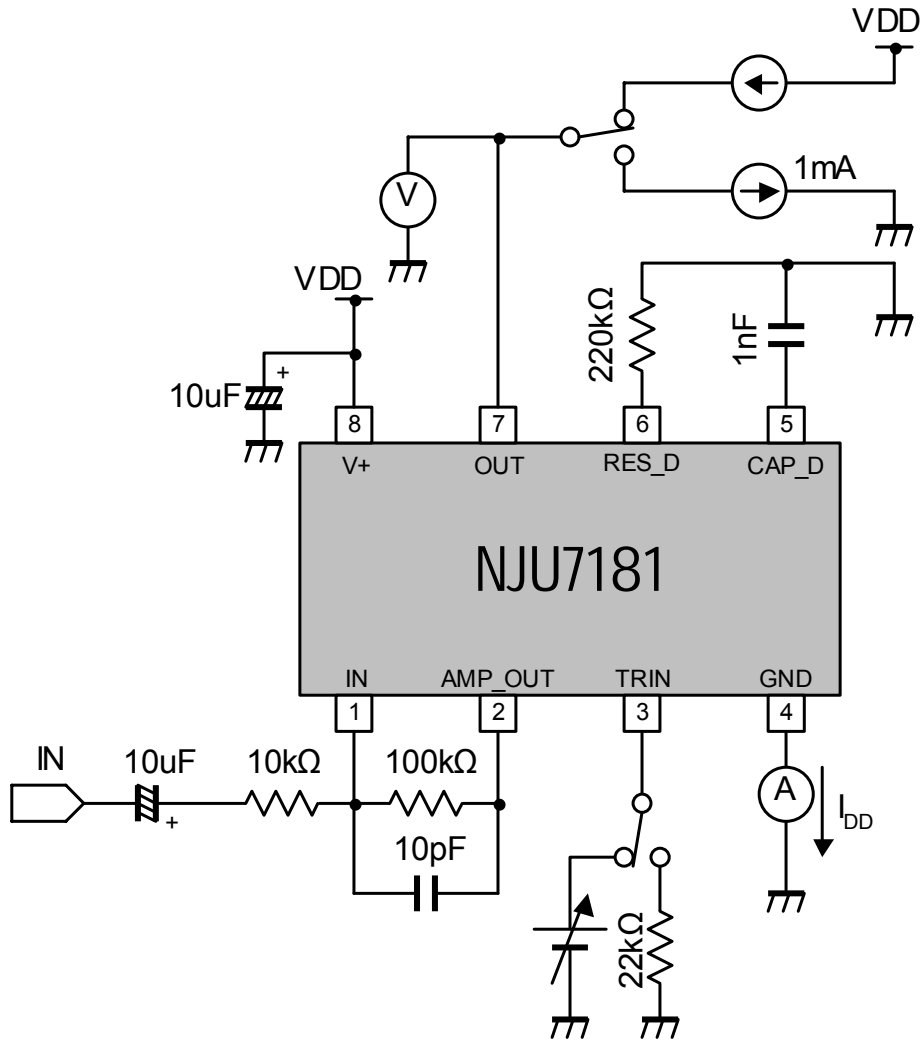

APPLICATION CIRCUIT

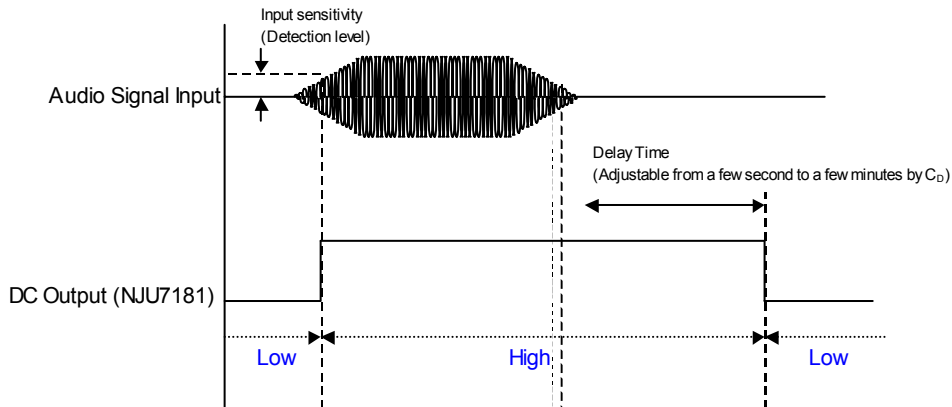
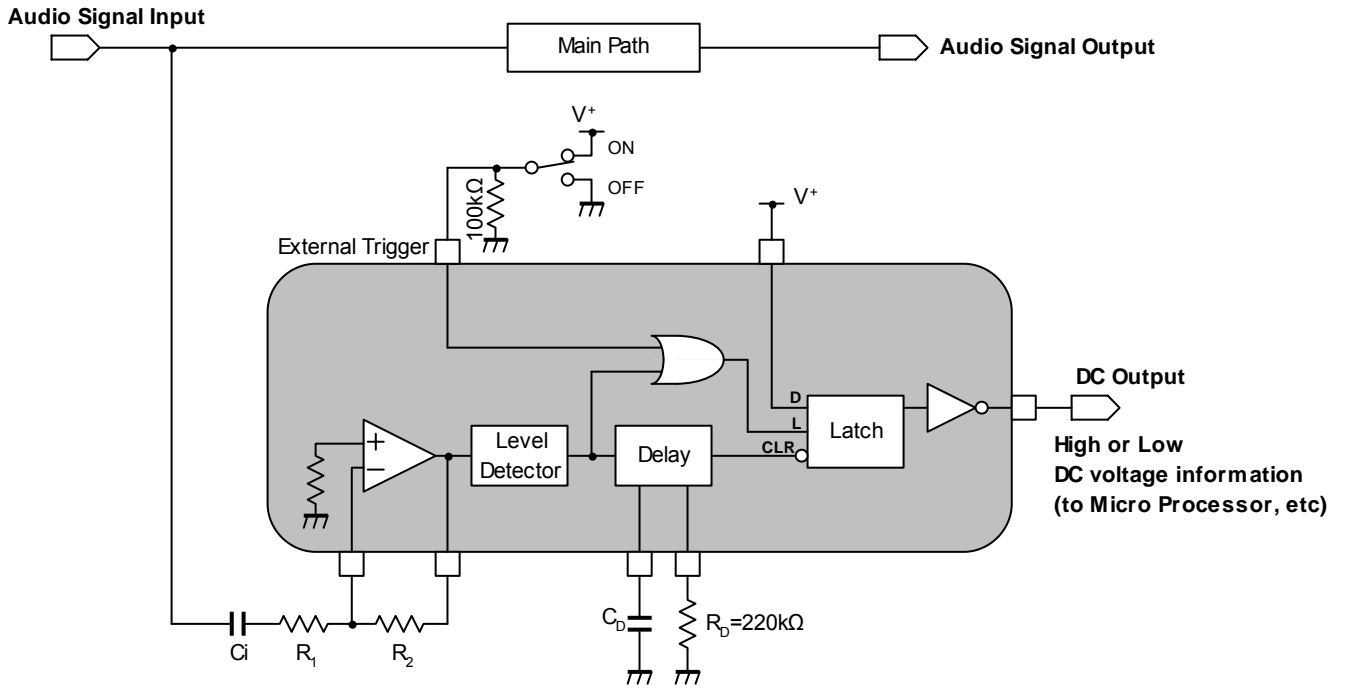

NJU7181

Attack Time:



Note:

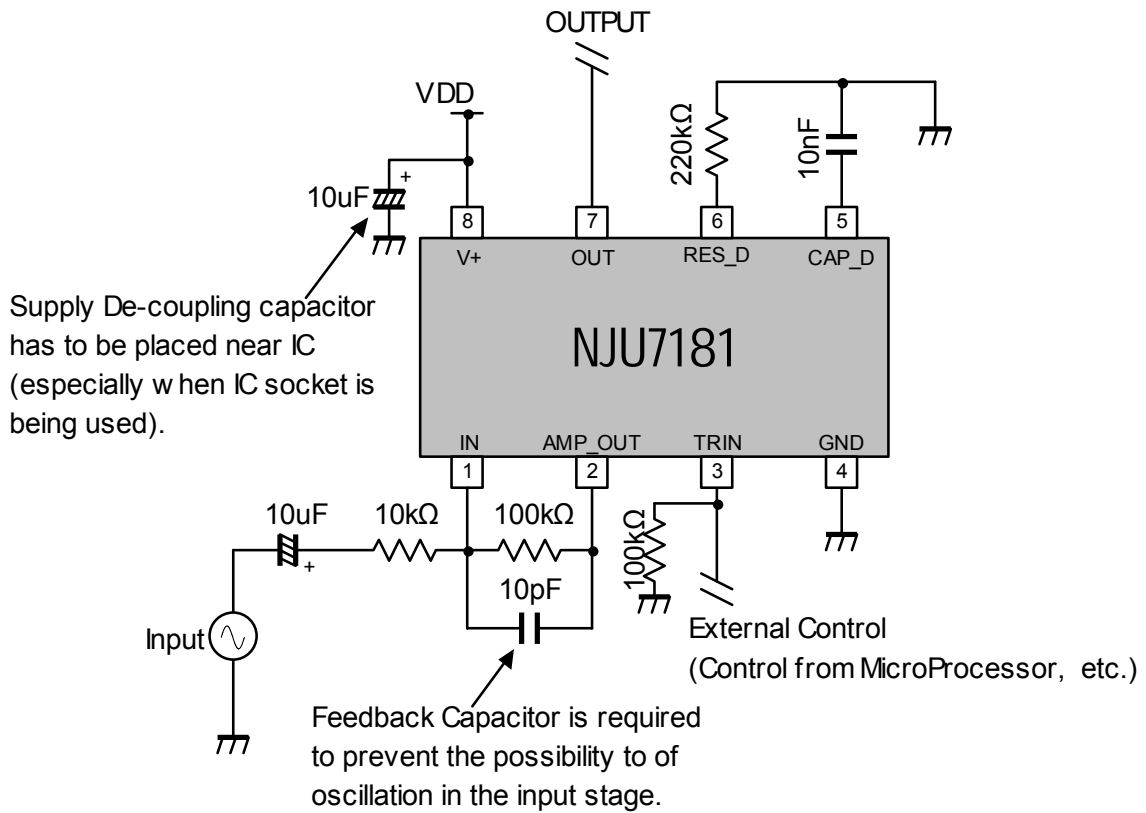

■ APPLICATION NOTE

- **DC Output Waveform Scenario**

Scenario 1: Power-ON

– Output will be high initially when NJU7181 is first powered up even if there is no input signal detected.

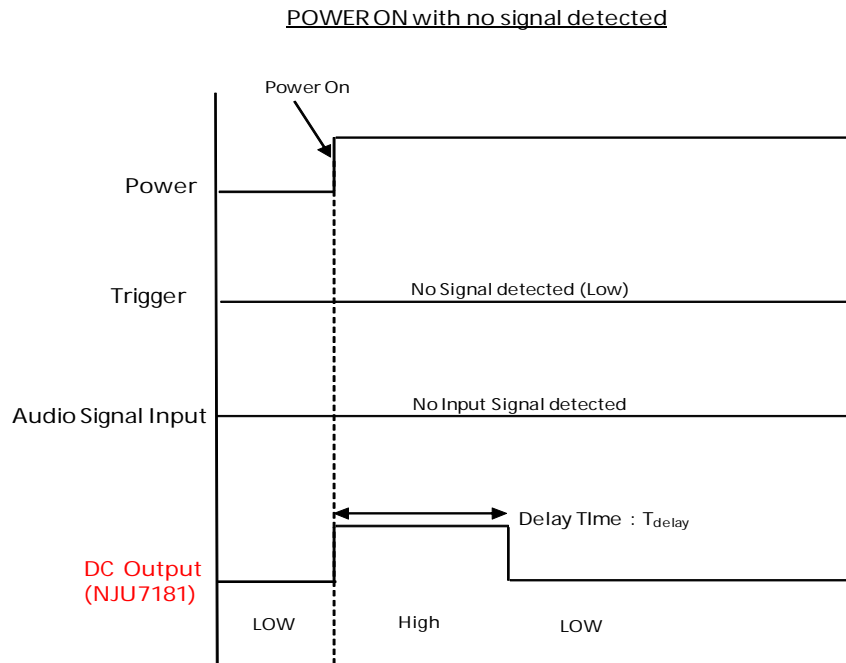

Scenario 2: Only Audio Signal detected

– Output will be or maintain high when **either an input signal or trigger signal is detected**. The delay circuit will only be activated **when both signals is not present**. NJU7181 will then hold the output level for a delay time which can be adjusted by the Capacitor value @ pin 5.

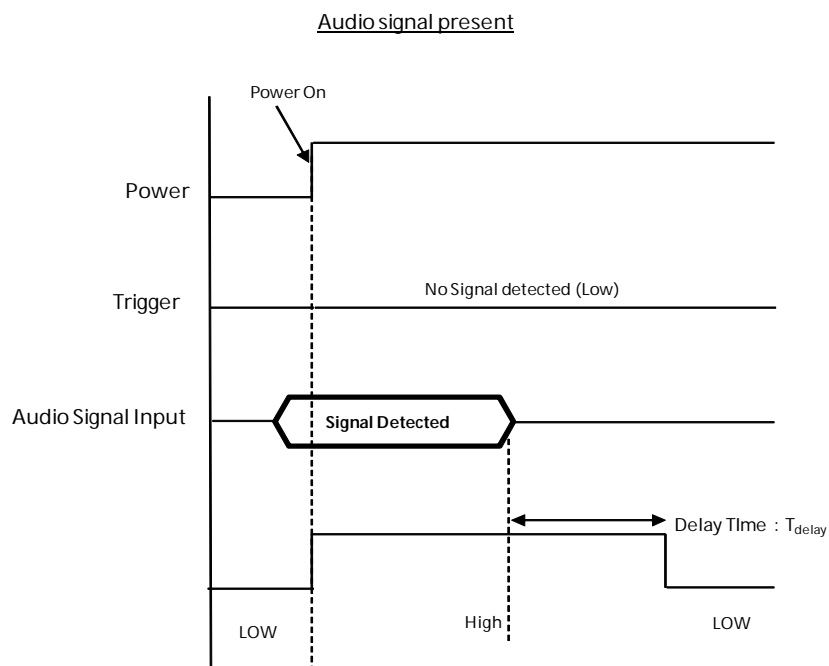

Scenario 3: Trigger Signal detected (Case 1)

– Output will be or maintain high when **either an input signal or trigger signal is detected**. The delay circuit will only be activated **when both signals is not present**. Output is set to Low state when a delay time passes. Output is set to High state when either an input signal or trigger signal is detected again.

Case 1: Trigger signal present (After output LOW)

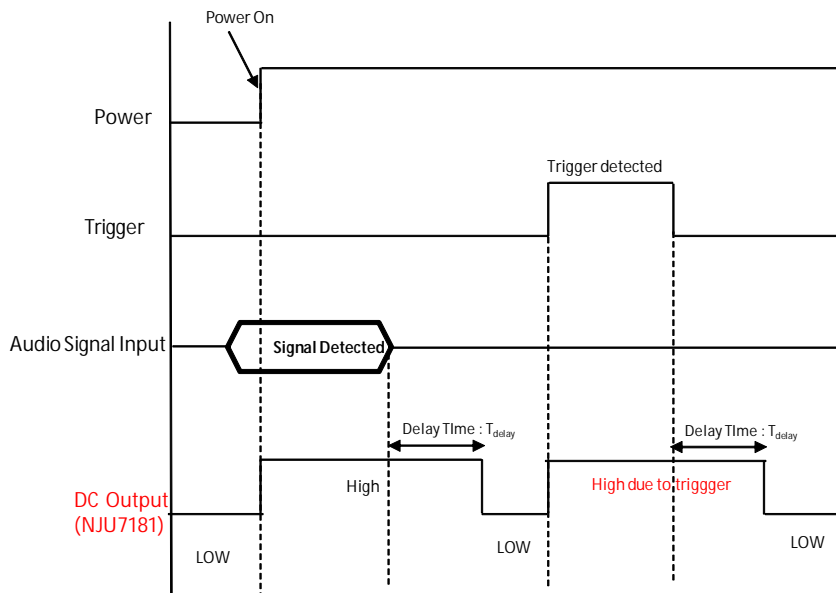

Scenario 4: Trigger Signal detected (Case 2)

– Output will be or maintain high when **either an input signal or trigger signal is detected**. When hold time is shorter than a delay time, output maintains High state (Counter RESET). NJU7181 will then hold the output level for a delay time which can be adjusted by the Capacitor value @ pin 5.

Case 2: Trigger signal present (During output HIGH)

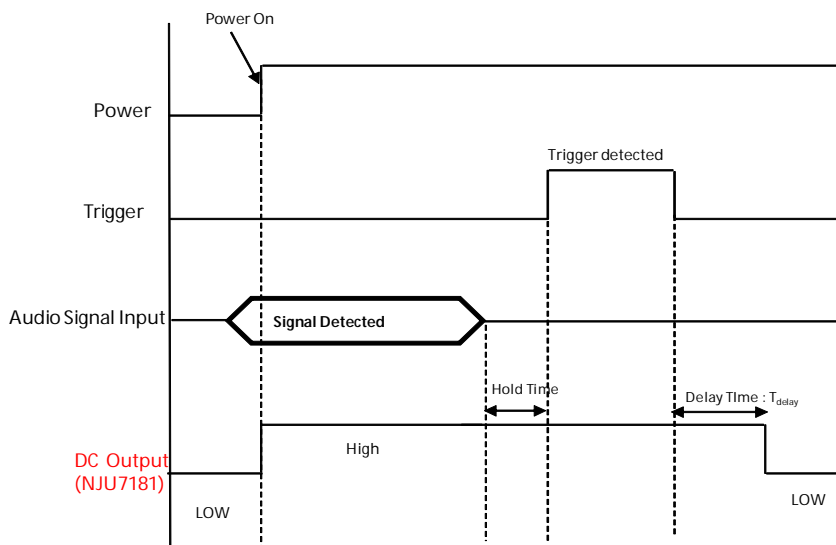

When hold time is shorter than T_{delay} , DC_Output maintains High state. (Counter RESET)

◆ Input Sensitivity [Ta =25°C]

The input sensitivity is defined as follows.

$$V_{INS}=20*\log(R1/R2) - 21.5 \text{ [dBV]} \text{ ---- (1)}$$

Note) The input sensitivity recommends the setting of -60dBV (1mVrms) or more.

Note) The R2 value should be 100kΩ or more.

◆ Frequency Response

The input capacitor “Ci” forms HPF with “R1”. The cut-off frequency is defined as follows. Please decide C1 value in consideration of the frequency response necessary for the signal-detecting.

$$f_c=1/(2\pi\times C_i\times R_1) \text{ [Hz]} \text{ ---- (2)}$$

◆ Delay time [With R_D = 220Kohm]

The Recovery time is defined as follows.

$$T_{\text{delay}}=1.5*10^8*C_R \text{ [sec]} \text{ ---- (3)}$$

■ TERMINAL DESCRIPTION

Terminal	SYMBOL	FUNCTION	EQUIVALENT CIRCUIT	VOLTAGE
1	IN	AC Input		0.3V
2	AMP_OUT	Amplifier Output		0.3V
3	TRIN	External Trigger Input		-
5	CAP_D	Delay Time Capacitor		0V

■ TERMINAL DESCRIPTION

Terminal	SYMBOL	FUNCTION	EQUIVALENT CIRCUIT	VOLTAGE
6	RES_D	Delay Time Resistor		$3\mu\text{A} \times R_D$
7	OUT	DC Output		0 or V^+
8	V^+	Supply Voltage		V^+

■ TYPICAL CHARACTERISTICS

Operating Current Vs Operating Voltage
Cd = 10nF, Rd = 220kΩ, No Input

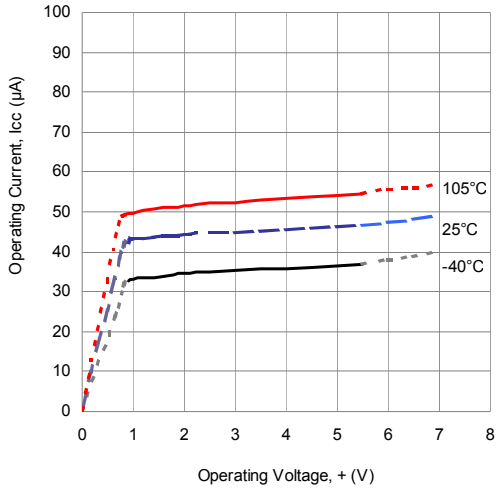

Operating current Vs Temperature
VDD = 3V, Cd = 10nF, Rd = 220kΩ, No Input

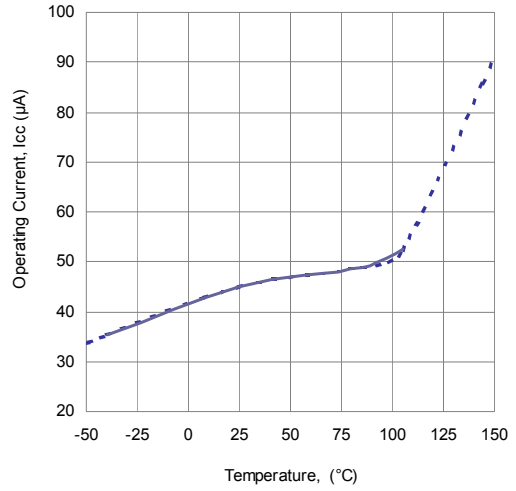

Output Voltage Vs Output Current Source
VDD = 3V, Ta = 25°C, Cd = 10nF, Rd = 220kΩ, Output = High

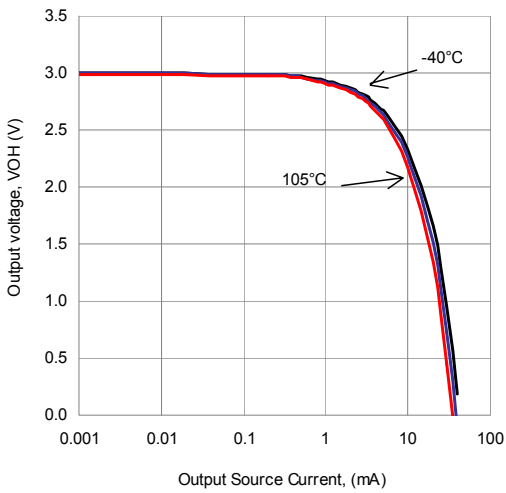

Output Voltage Vs Output Current Sink
VDD = 3V, Ta = 25°C, Cd = 10nF, Rd = 220kΩ, Output = High

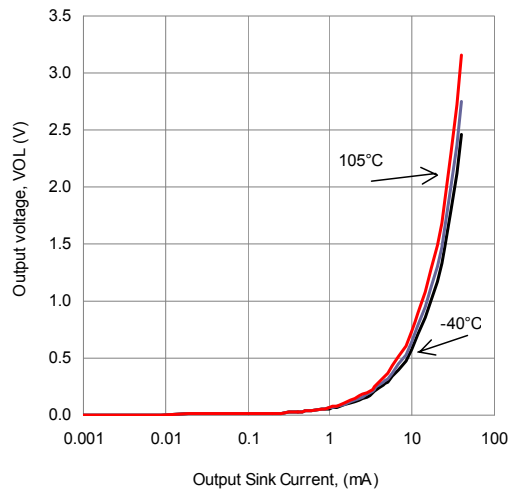

Output Voltage Vs Temperature
VDD = 3V, Cd = 10nF, Rd = 220kΩ, Output = High,
Current Source = 1mA

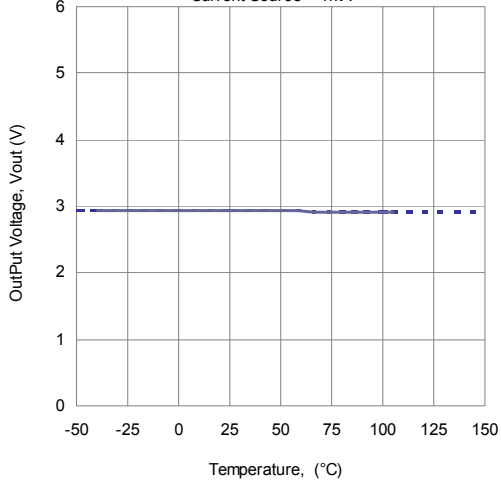

Output Voltage Vs Temperature
VDD = 3V, Cd = 10nF, Rd = 220kΩ, Output = High,
Current Sink = 1mA

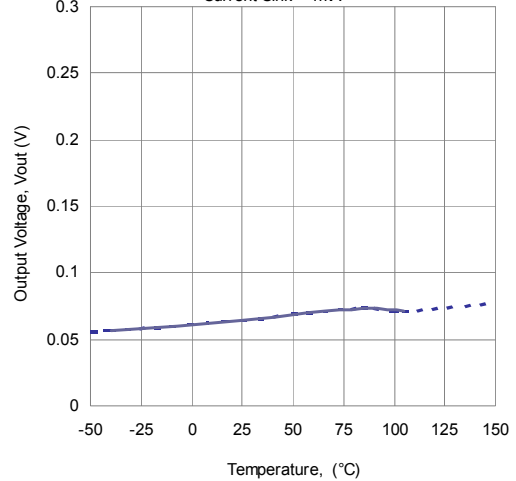

■ TYPICAL CHARACTERISTICS

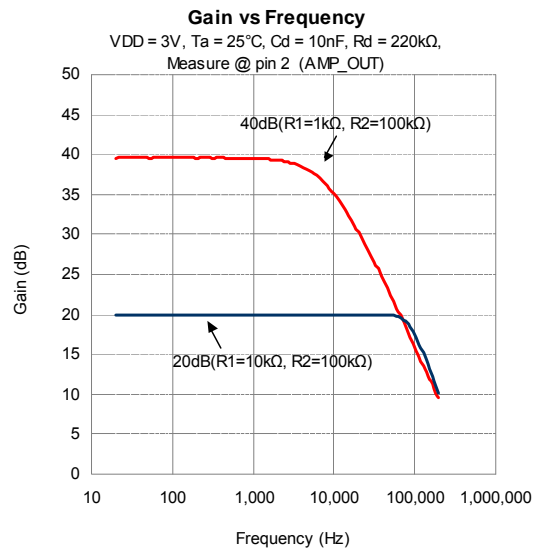
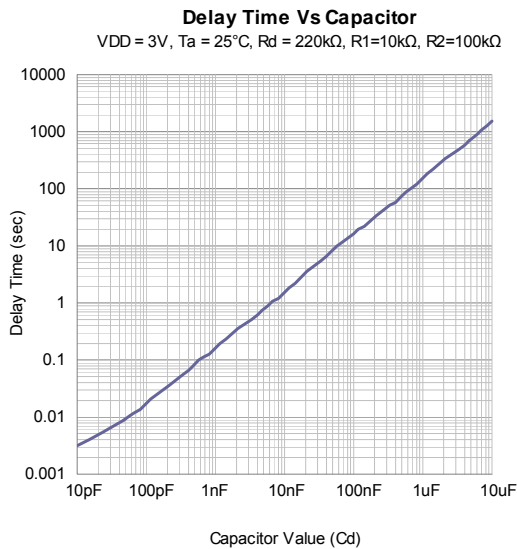
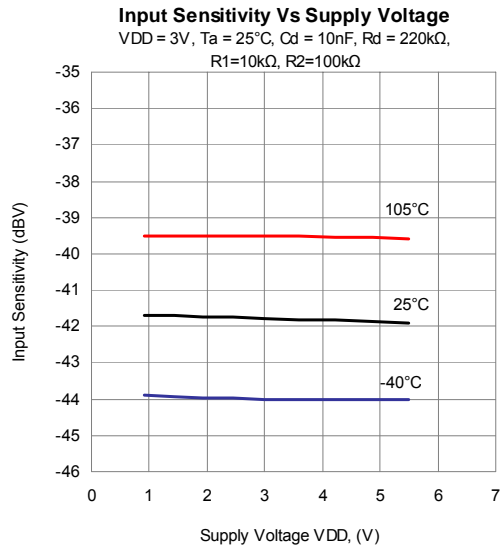
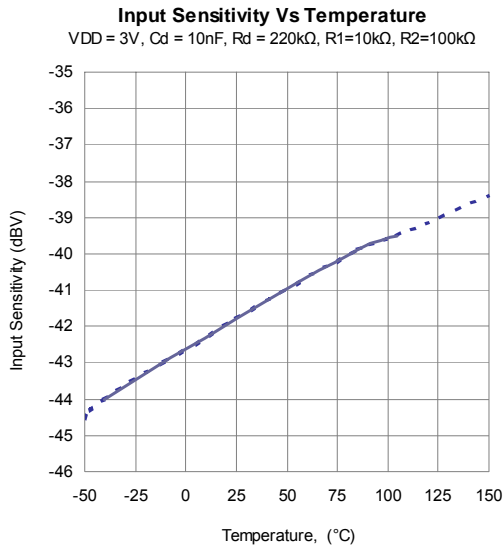

[CAUTION]
 The specifications on this databook are only given for information, without any guarantee as regards either mistakes or omissions. The application circuits in this databook are described only to show representative usages of the product and not intended for the guarantee or permission of any right including the industrial rights.

Компания «Life Electronics» занимается поставками электронных компонентов импортного и отечественного производства от производителей и со складов крупных дистрибьюторов Европы, Америки и Азии.

С конца 2013 года компания активно расширяет линейку поставок компонентов по направлению коаксиальный кабель, кварцевые генераторы и конденсаторы (керамические, пленочные, электролитические), за счёт заключения дистрибьюторских договоров

Мы предлагаем:

- Конкурентоспособные цены и скидки постоянным клиентам.
- Специальные условия для постоянных клиентов.
- Подбор аналогов.
- Поставку компонентов в любых объемах, удовлетворяющих вашим потребностям.
- Приемлемые сроки поставки, возможна ускоренная поставка.
- Доставку товара в любую точку России и стран СНГ.
- Комплексную поставку.
- Работу по проектам и поставку образцов.
- Формирование склада под заказчика.
- Сертификаты соответствия на поставляемую продукцию (по желанию клиента).
- Тестирование поставляемой продукции.
- Поставку компонентов, требующих военную и космическую приемку.
- Входной контроль качества.
- Наличие сертификата ISO.

В составе нашей компании организован Конструкторский отдел, призванный помогать разработчикам, и инженерам.

Конструкторский отдел помогает осуществить:

- Регистрацию проекта у производителя компонентов.
- Техническую поддержку проекта.
- Защиту от снятия компонента с производства.
- Оценку стоимости проекта по компонентам.
- Изготовление тестовой платы монтаж и пусконаладочные работы.



Тел: +7 (812) 336 43 04 (многоканальный)

Email: org@lifeelectronics.ru