

General Description

The ICS83940DI is a low skew, 1-to-18 LVPECL-to-LVCMOS/LVTTL Fanout Buffer. The ICS83940DI has two selectable clock inputs. The PCLK, nPCLK pair can accept LVPECL, CML, or SSTL input levels. The LVCMOS_CLK can accept LVCMOS or LVTTL input levels. The low impedance LVCMOS/LVTTL outputs are designed to drive 50Ω series or parallel terminated transmission lines.

The ICS83940DI is characterized at full 3.3V and 2.5V or mixed 3.3V core, 2.5V output operating supply modes. Guaranteed output and part-to-part skew characteristics make the ICS83940DI ideal for those clock distribution applications demanding well defined performance and repeatability.

Block Diagram

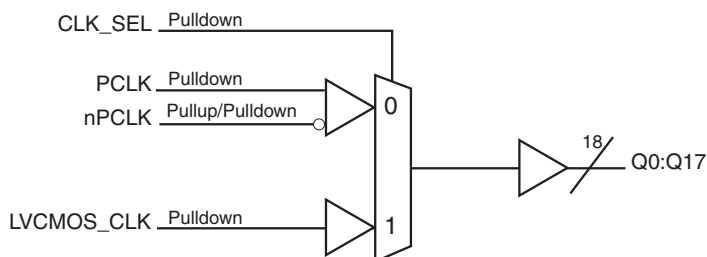

Features

- Eighteen LVCMOS/LVTTL outputs
- Selectable LVCMOS_CLK or LVPECL clock inputs
- PCLK, nPCLK pair can accept the following differential input levels: LVPECL, CML, SSTL
- LVCMOS_CLK supports the following input types: LVCMOS or LVTTL
- Maximum output frequency: 250MHz
- Output skew: 150ps (maximum)
- Part-to-part skew: 750ps (maximum)
- Operating supply modes:
 - Core/Output 3.3V/3.3V
 - 3.3V/2.5V
 - 2.5V/2.5V
- -40°C to 85°C ambient operating temperature
- Lead-free (RoHS 6) packaging
- **For functional replacement part for 83940DKILF use 87016i**

Pin Assignments

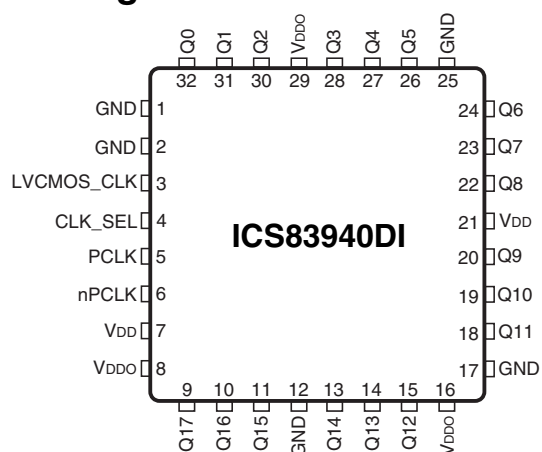

32 Lead VFQFN
5mm x 5mm x 0.925mm package body
K Package
Top View

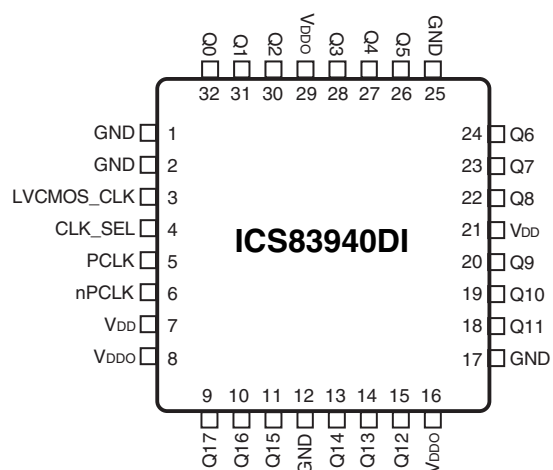

32-Lead LQFP
7mm x 7mm x 1.4mm package body
Y Package
Top View

Pin Descriptions and Characteristics

Table 1. Pin Descriptions

Number	Name	Type		Description
1, 2, 12, 17, 25	GND	Power		Power supply ground.
3	LVCMOS_CLK	Input	Pulldown	Single-ended clock input. LVCMOS/LVTTL interface levels.
4	CLK_SEL	Input	Pulldown	Clock select input. When HIGH, selects LVCMOS_CLK input. When LOW, selects PCLK, nPCLK inputs. LVCMOS / LVTTL interface levels.
5	PCLK	Input	Pulldown	Non-inverting differential LVPECL clock input.
6	nPCLK	Input	Pullup/ Pulldown	Inverting differential LVPECL clock input. $V_{DD}/2$ default when left floating.
7, 21	V_{DD}	Power		Power supply pin.
8, 16, 29	V_{DDO}	Power		Output supply pins.
9, 10, 11, 13, 14, 15, 18, 19, 20, 22, 23, 24, 26, 27, 28, 30, 31, 32	Q17, Q16, Q15, Q14, Q13, Q12, Q11, Q10, Q9, Q8, Q7, Q6, Q5, Q4, Q3, Q2, Q1, Q0	Output		Single-ended clock outputs. LVCMOS/LVTTL interface levels.

NOTE: *Pullup and Pulldown* refers to internal input resistors. See Table 2, *Pin Characteristics*, for typical values.

Table 2. Pin Characteristics

Symbol	Parameter	Test Conditions	Minimum	Typical	Maximum	Units
C_{IN}	Input Capacitance			4		pF
R_{PULLUP}	Input Pullup Resistor			51		k Ω
$R_{PULLDOWN}$	Input Pulldown Resistor			51		k Ω
C_{PD}	Power Dissipation Capacitance (per output)			6		pF
R_{OUT}	Output Impedance		18		28	Ω

Function Tables

Table 3A. Clock Select Function Table

Control Input	Clock	
CLK_SEL	PCLK, nPCLK	LVC MOS_CLK
0	Selected	De-selected
1	De-selected	Selected

Table 3B. Clock Input Function Table

Inputs				Outputs	Input to Output Mode	Polarity
CLK_SEL	LVC MOS_CLK	PCLK	nPCLK	Q[0:17]		
0	–	0	1	LOW	Differential to Single-Ended	Non-Inverting
0	–	1	0	HIGH	Differential to Single-Ended	Non-Inverting
0	–	0	Biased; NOTE 1	LOW	Single-Ended to Single-Ended	Non-Inverting
0	–	1	Biased; NOTE 1	HIGH	Single-Ended to Single-Ended	Non-Inverting
0	–	Biased; NOTE 1	0	HIGH	Single-Ended to Single-Ended	Inverting
0	–	Biased; NOTE 1	1	LOW	Single-Ended to Single-Ended	Inverting
1	0	–	–	LOW	Single-Ended to Single-Ended	Non-Inverting
1	1	–	–	HIGH	Single-Ended to Single-Ended	Non-Inverting

NOTE 1: Please refer to the Application Information Section, *Wiring the Differential Input to Accept Single-ended Levels*.

Absolute Maximum Ratings

NOTE: Stresses beyond those listed under *Absolute Maximum Ratings* may cause permanent damage to the device. These ratings are stress specifications only. Functional operation of product at these conditions or any conditions beyond those listed in the *DC Characteristics* or *AC Characteristics* is not implied. Exposure to absolute maximum rating conditions for extended periods may affect product reliability.

Item	Rating
Supply Voltage, V_{DD}	3.6V
Inputs, V_I	-0.3V to $V_{DD} + 0.3V$
Outputs, V_O	-0.3V to $V_{DDO} + 0.3V$
Input Current, I_{IN}	$\pm 20mA$
Storage Temperature, T_{STG}	-65°C to 150°C

DC Electrical Characteristics

Table 4A. DC Characteristics, $V_{DD} = V_{DDO} = 3.3V \pm 5\%$, $T_A = -40^\circ C$ to $85^\circ C$

Symbol	Parameter	Test Conditions	Minimum	Typical	Maximum	Units
V_{IH}	Input High Voltage	LVC MOS_CLK	2.4		V_{DD}	V
V_{IL}	Input Low Voltage	LVC MOS_CLK			0.8	V
I_{IN}	Input Current				± 200	μA
V_{OH}	Output High Voltage	$I_{OH} = -20mA$	2.4			V
V_{OL}	Output Low Voltage	$I_{OL} = 20mA$			0.5	V
V_{PP}	Peak-to-Peak Input Voltage; NOTE 1	PCLK, nPCLK	500		1000	mV
V_{CMR}	Common Mode Input Voltage; NOTE 1, 2	PCLK, nPCLK	$V_{DD} - 1.45$		$V_{DD} - 0.6$	V
I_{DD}	Power Supply Current				25	mA

NOTE 1: V_{IL} should not be less than -0.3V.

NOTE 2: Common mode voltage is defined as V_{IH} .

Table 4B. DC Characteristics, $V_{DD} = 3.3V \pm 5\%$, $V_{DDO} = 2.5V \pm 5\%$, $T_A = -40^\circ C$ to $85^\circ C$

Symbol	Parameter	Test Conditions	Minimum	Typical	Maximum	Units
V_{IH}	Input High Voltage	LVC MOS_CLK	2.4		V_{DD}	V
V_{IL}	Input Low Voltage	LVC MOS_CLK			0.8	V
I_{IN}	Input Current				± 200	μA
V_{OH}	Output High Voltage	$I_{OH} = -20mA$	1.8			V
V_{OL}	Output Low Voltage	$I_{OL} = 20mA$			0.5	V
V_{PP}	Peak-to-Peak Input Voltage; NOTE 1	PCLK, nPCLK	300		1000	mV
V_{CMR}	Common Mode Input Voltage; NOTE 1, 2	PCLK, nPCLK	$V_{DD} - 1.4$		$V_{DD} - 0.6$	V
I_{DD}	Power Supply Current				25	mA

NOTE 1: V_{IL} should not be less than -0.3V.

NOTE 2: Common mode voltage is defined as V_{IH} .

Table 4C. DC Characteristics, $V_{DD} = V_{DDO} = 2.5V \pm 5\%$, $T_A = -40^{\circ}C$ to $85^{\circ}C$

Symbol	Parameter		Test Conditions	Minimum	Typical	Maximum	Units
V_{IH}	Input High Voltage	LVCMOS_CLK		2		V_{DD}	V
V_{IL}	Input Low Voltage	LVCMOS_CLK				0.8	V
I_{IN}	Input Current					± 200	μA
V_{OH}	Output High Voltage		$I_{OH} = -12mA$	1.8			V
V_{OL}	Output Low Voltage		$I_{OL} = 12mA$			0.5	V
V_{PP}	Peak-to-Peak Input Voltage; NOTE 1	PCLK, nPCLK		300		1000	mV
V_{CMR}	Common Mode Input Voltage; NOTE 1, 2	PCLK, nPCLK		$V_{DD} - 1.4$		$V_{DD} - 0.6$	V
I_{DD}	Power Supply Current					25	mA

NOTE 1: V_{IL} should not be less than -0.3V.NOTE 2: Common mode voltage is defined as V_{IH} .

AC Electrical Characteristics

Table 5A. AC Characteristics, $V_{DD} = V_{DDO} = 3.3V \pm 5\%$, $T_A = -40^{\circ}C$ to $85^{\circ}C$

Symbol	Parameter	Test Conditions	Minimum	Typical	Maximum	Units	
f_{MAX}	Output Frequency				250	MHz	
t_{PLH}	Propagation Delay	PCLK, nPCLK; NOTE 1, 5	$f \leq 150MHz$	1.6		3.0	ns
		LVCMOS_CLK; NOTE 2, 5	$f \leq 150MHz$	1.8		3.0	ns
	Propagation Delay	PCLK, nPCLK; NOTE 1, 5	$f > 150MHz$	1.6		3.3	ns
		LVCMOS_CLK; NOTE 2, 5	$f > 150MHz$	1.8		3.2	ns
$t_{sk(o)}$	Output Skew; NOTE 3, 5	PCLK, nPCLK	Measured on the Rising Edge @ $V_{DDO}/2$			150	ps
		LVCMOS_CLK				150	ps
$t_{sk(pp)}$	Part-to-Part Skew; NOTE 6	PCLK, nPCLK	$f \leq 150MHz$			1.4	ns
		LVCMOS_CLK	$f \leq 150MHz$			1.2	ns
	Part-to-Part Skew; NOTE 6	PCLK, nPCLK	$f > 150MHz$			1.7	ns
		LVCMOS_CLK	$f > 150MHz$			1.4	ns
	Part-to-Part Skew; NOTE 4, 5	PCLK, nPCLK	Measured on the Rising Edge @ $V_{DDO}/2$			850	ps
		LVCMOS_CLK				750	ps
t_R / t_F	Output Rise/Fall Time	0.5V to 2.4V	0.3		1.1	ns	
odc	Output Duty Cycle	$f < 134MHz$	45	50	55	%	
		$134MHz \leq f \leq 250MHz$	40	50	60	%	

NOTE: Electrical parameters are guaranteed over the specified ambient operating temperature range, which is established when the device is mounted in a test socket with maintained transverse airflow greater than 500 lfm. The device will meet specifications after thermal equilibrium has been reached under these conditions.

NOTE: All parameters measured at 200MHz unless noted otherwise.

NOTE 1: Measured from the differential input crossing point to the output $V_{DDO}/2$.

NOTE 2: Measured from $V_{DD}/2$ to $V_{DDO}/2$.

NOTE 3: Defined as skew between outputs at the same supply voltage and with equal load conditions. Measured at $V_{DDO}/2$.

NOTE 4: Defined as skew between outputs on different devices operating at the same supply voltage, same temperature and with equal load conditions. Using the same type of inputs on each device, the outputs are measured at $V_{DDO}/2$.

NOTE 5: This parameter is defined in accordance with JEDEC Standard 65.

NOTE 6: Defined as skew between outputs on different devices, across temperature and voltage ranges, and with equal load conditions. Using the same type of inputs on each device, the outputs are measured at $V_{DDO}/2$.

Table 5B. AC Characteristics, $V_{DD} = 3.3V \pm 5\%$, $V_{DDO} = 2.5V \pm 5\%$, $T_A = -40^\circ\text{C}$ to 85°C

Symbol	Parameter	Test Conditions	Minimum	Typical	Maximum	Units	
f_{MAX}	Output Frequency				250	MHz	
t_{PLH}	Propagation Delay	PCLK, nPCLK; NOTE 1, 5	$f \leq 150\text{MHz}$	1.7	3.2	ns	
		LVCMOS_CLK; NOTE 2, 5	$f \leq 150\text{MHz}$	1.7	3.0	ns	
	Propagation Delay	PCLK, nPCLK; NOTE 1, 5	$f > 150\text{MHz}$	1.6	3.4	ns	
		LVCMOS_CLK; NOTE 2, 5	$f > 150\text{MHz}$	1.8	3.3	ns	
$t_{sk(o)}$	Output Skew; NOTE 3, 5	PCLK, nPCLK	Measured on the Rising Edge @ $V_{DDO}/2$		150	ps	
		LVCMOS_CLK			150	ps	
$t_{sk(pp)}$	Part-to-Part Skew; NOTE 6	PCLK, nPCLK	$f \leq 150\text{MHz}$		1.5	ns	
		LVCMOS_CLK	$f \leq 150\text{MHz}$		1.3	ns	
	Part-to-Part Skew; NOTE 6	PCLK, nPCLK	$f > 150\text{MHz}$		1.8	ns	
		LVCMOS_CLK	$f > 150\text{MHz}$		1.5	ns	
	Part-to-Part Skew; NOTE 4, 5	PCLK, nPCLK	Measured on the Rising Edge @ $V_{DDO}/2$			850	ps
		LVCMOS_CLK				750	ps
t_R / t_F	Output Rise/Fall Time	0.5V to 1.8V	0.3		1.2	ns	
odc	Output Duty Cycle	$f < 134\text{MHz}$	45	50	55	%	

NOTE: Electrical parameters are guaranteed over the specified ambient operating temperature range, which is established when the device is mounted in a test socket with maintained transverse airflow greater than 500 lfm. The device will meet specifications after thermal equilibrium has been reached under these conditions.

NOTE: All parameters measured at 200MHz unless noted otherwise.

NOTE 1: Measured from the differential input crossing point to the output $V_{DDO}/2$.

NOTE 2: Measured from $V_{DD}/2$ to $V_{DDO}/2$.

NOTE 3: Defined as skew between outputs at the same supply voltage and with equal load conditions. Measured at $V_{DDO}/2$.

NOTE 4: Defined as skew between outputs on different devices operating at the same supply voltage, same temperature and with equal load conditions. Using the same type of inputs on each device, the outputs are measured at $V_{DDO}/2$.

NOTE 5: This parameter is defined in accordance with JEDEC Standard 65.

NOTE 6: Defined as skew between outputs on different devices, across temperature and voltage ranges, and with equal load conditions. Using the same type of inputs on each device, the outputs are measured at $V_{DDO}/2$.

Table 5C. AC Characteristics, $V_{DD} = V_{DDO} = 2.5V \pm 5\%$, $T_A = -40^{\circ}C$ to $85^{\circ}C$

Symbol	Parameter	Test Conditions	Minimum	Typical	Maximum	Units	
f_{MAX}	Output Frequency				200	MHz	
t_{PLH}	Propagation Delay	PCLK, nPCLK; NOTE 1, 5	$f \leq 150MHz$	1.2	3.8	ns	
		LVCMOS_CLK; NOTE 2, 5	$f \leq 150MHz$	1.5	3.2	ns	
	Propagation Delay	PCLK, nPCLK; NOTE 1, 5	$f > 150MHz$	1.5	3.7	ns	
		LVCMOS_CLK; NOTE 2, 5	$f > 150MHz$	2.0	3.6	ns	
$t_{sk(o)}$	Output Skew; NOTE 3, 5	PCLK, nPCLK	Measured on the Rising Edge @ $V_{DDO}/2$		200	ps	
		LVCMOS_CLK			200	ps	
$t_{sk(pp)}$	Part-to-Part Skew; NOTE 6	PCLK, nPCLK	$f \leq 150MHz$		2.6	ns	
		LVCMOS_CLK	$f \leq 150MHz$		1.7	ns	
	Part-to-Part Skew; NOTE 6	PCLK, nPCLK	$f > 150MHz$		2.2	ns	
		LVCMOS_CLK	$f > 150MHz$		1.7	ns	
	Part-to-Part Skew; NOTE 4, 5	PCLK, nPCLK	Measured on the Rising Edge @ $V_{DDO}/2$			1.2	ns
		LVCMOS_CLK				1.0	ns
t_R / t_F	Output Rise/Fall Time	0.5V to 1.8V	0.3		1.2	ns	
odc	Output Duty Cycle	$f < 134MHz$	45		55	%	

NOTE: Electrical parameters are guaranteed over the specified ambient operating temperature range, which is established when the device is mounted in a test socket with maintained transverse airflow greater than 500 lfm. The device will meet specifications after thermal equilibrium has been reached under these conditions.

NOTE: All parameters measured at 200MHz unless noted otherwise.

NOTE 1: Measured from the differential input crossing point to the output $V_{DDO}/2$.

NOTE 2: Measured from $V_{DD}/2$ to $V_{DDO}/2$.

NOTE 3: Defined as skew between outputs at the same supply voltage and with equal load conditions. Measured at $V_{DDO}/2$.

NOTE 4: Defined as skew between outputs on different devices operating at the same supply voltage, same temperature and with equal load conditions. Using the same type of inputs on each device, the outputs are measured at $V_{DDO}/2$.

NOTE 5: This parameter is defined in accordance with JEDEC Standard 65.

NOTE 6: Defined as skew between outputs on different devices, across temperature and voltage ranges, and with equal load conditions. Using the same type of inputs on each device, the outputs are measured at $V_{DDO}/2$.

Parameter Measurement Information

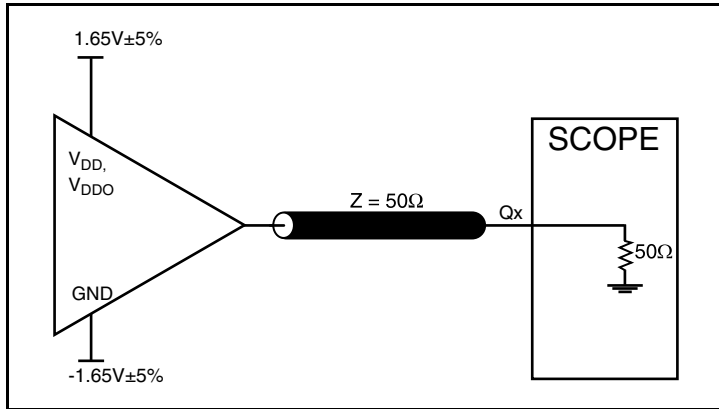

3.3V Core/3.3V LVCMOS Output Load AC Test Circuit

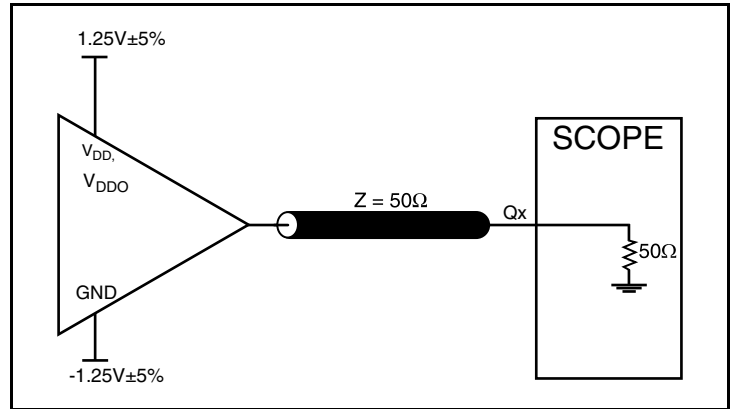

2.5V Core/2.5V LVCMOS Output Load AC Test Circuit

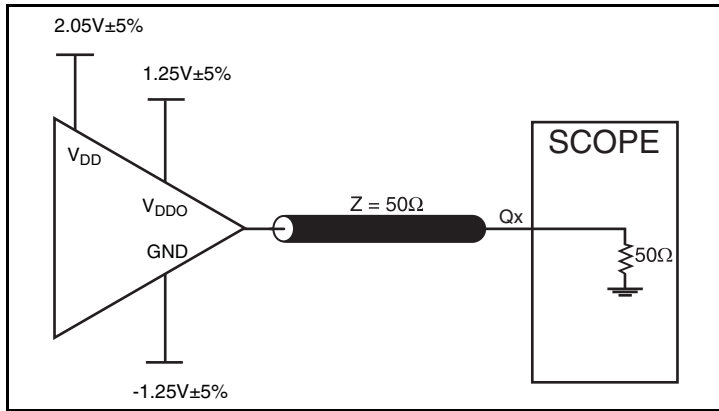

3.3V Core/2.5V LVCMOS Output Load AC Test Circuit

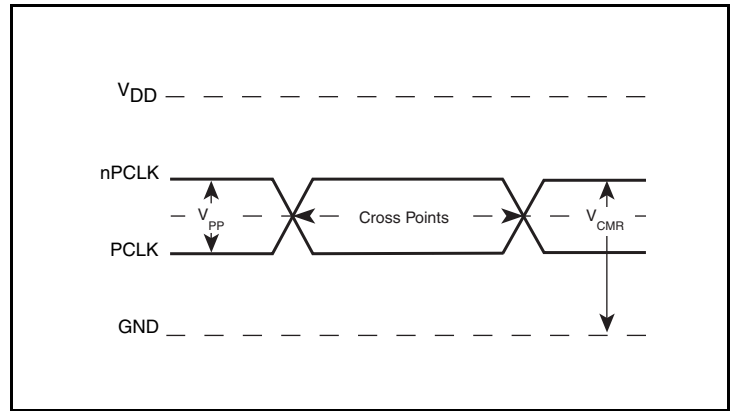

Differential Input Level

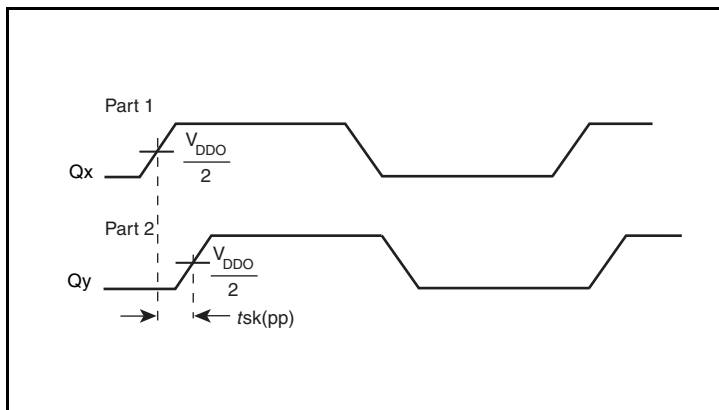

Part-to-Part Skew

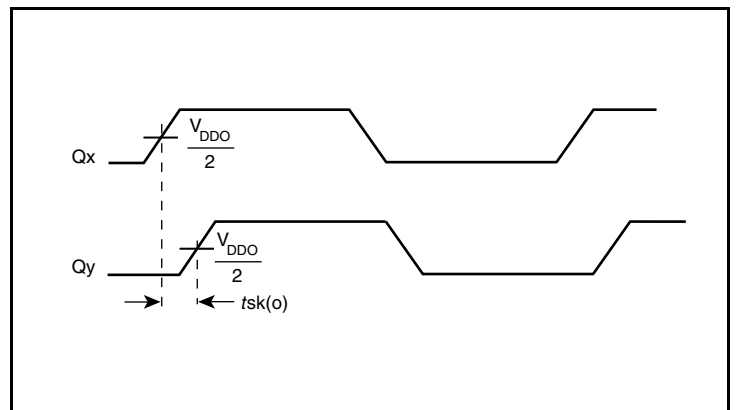

Output Skew

Parameter Measurement Information, continued

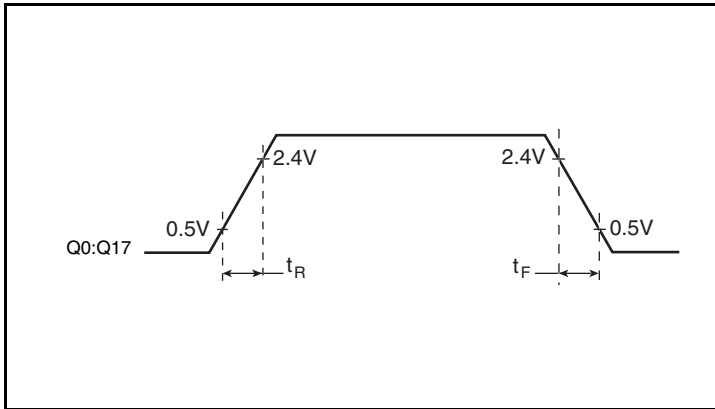

3.3V Output Rise/Fall Time

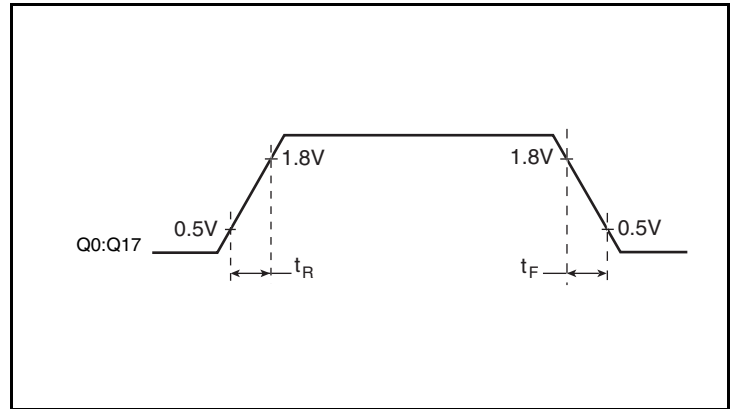

2.5V Output Rise/Fall Time

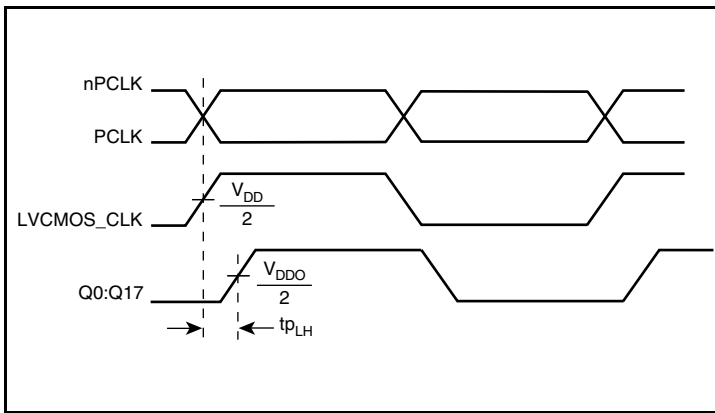

Propagation Delay

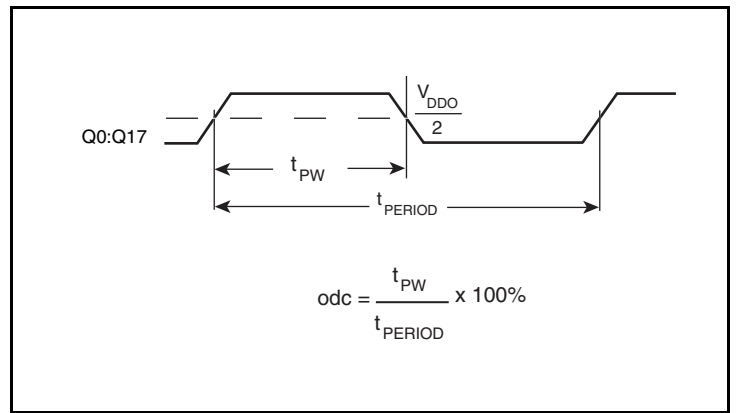

Output Duty Cycle/Pulse Width/Period

Application Information

Wiring the Differential Input to Accept Single-Ended Levels

Figure 1 shows how a differential input can be wired to accept single ended levels. The reference voltage $V_{REF} = V_{DD}/2$ is generated by the bias resistors R1 and R2. The bypass capacitor (C1) is used to help filter noise on the DC bias. This bias circuit should be located as close to the input pin as possible. The ratio of R1 and R2 might need to be adjusted to position the V_{REF} in the center of the input voltage swing. For example, if the input clock swing is 2.5V and $V_{DD} = 3.3V$, R1 and R2 value should be adjusted to set V_{REF} at 1.25V. The values below are for when both the single ended swing and V_{DD} are at the same voltage. This configuration requires that the sum of the output impedance of the driver (R_o) and the series resistance (R_s) equals the transmission line impedance. In addition, matched termination at the input will attenuate the signal in half. This can be done in one of two ways. First, R3 and R4 in parallel should equal the transmission

line impedance. For most 50 Ω applications, R3 and R4 can be 100 Ω . The values of the resistors can be increased to reduce the loading for slower and weaker LVCMOS driver. When using single-ended signaling, the noise rejection benefits of differential signaling are reduced. Even though the differential input can handle full rail LVCMOS signaling, it is recommended that the amplitude be reduced. The datasheet specifies a lower differential amplitude, however this only applies to differential signals. For single-ended applications, the swing can be larger, however V_{IL} cannot be less than -0.3V and V_{IH} cannot be more than $V_{DD} + 0.3V$. Though some of the recommended components might not be used, the pads should be placed in the layout. They can be utilized for debugging purposes. The datasheet specifications are characterized and guaranteed by using a differential signal.

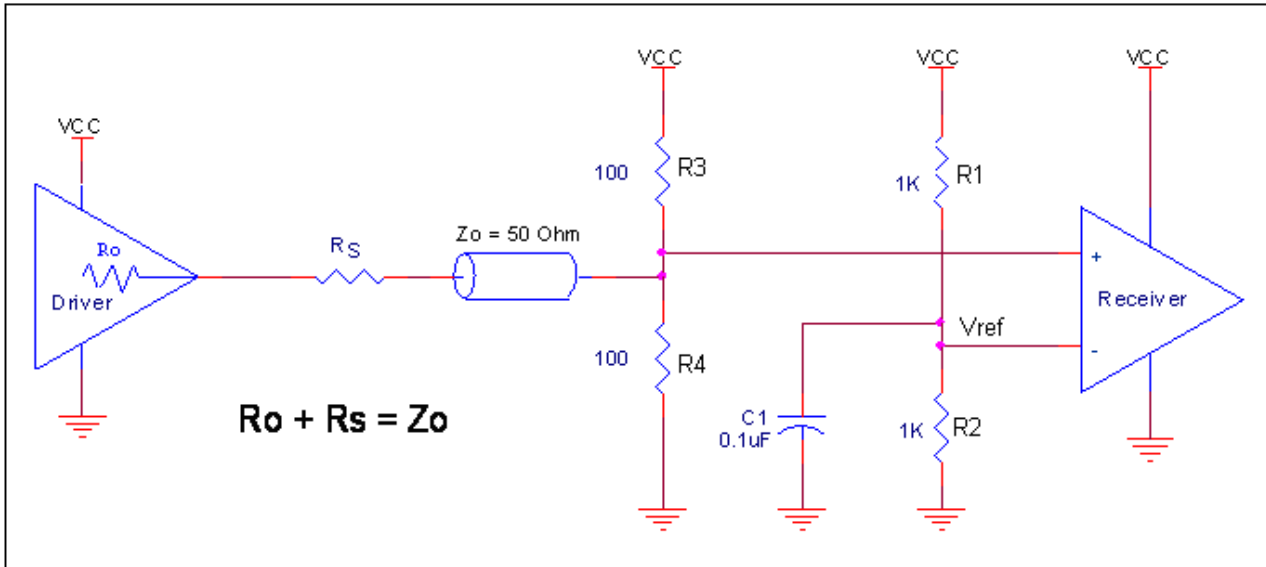

Figure 1. Recommended Schematic for Wiring a Differential Input to Accept Single-ended Levels

LVPECL Clock Input Interface

The PCLK /nPCLK accepts LVPECL, CML, SSTL and other differential signals. Both differential signals must meet the V_{PP} and V_{CMR} input requirements. Figures 2A to 2E show interface examples for the PCLK/nPCLK input driven by the most common driver types.

The input interfaces suggested here are examples only. If the driver is from another vendor, use their termination recommendation. Please consult with the vendor of the driver component to confirm the driver termination requirements.

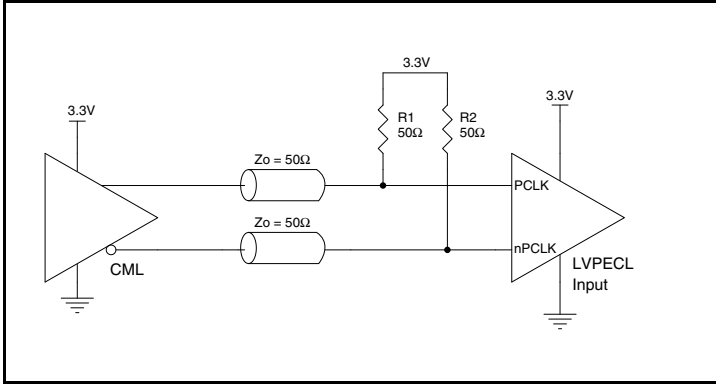

Figure 2A. PCLK/nPCLK Input Driven by a CML Driver

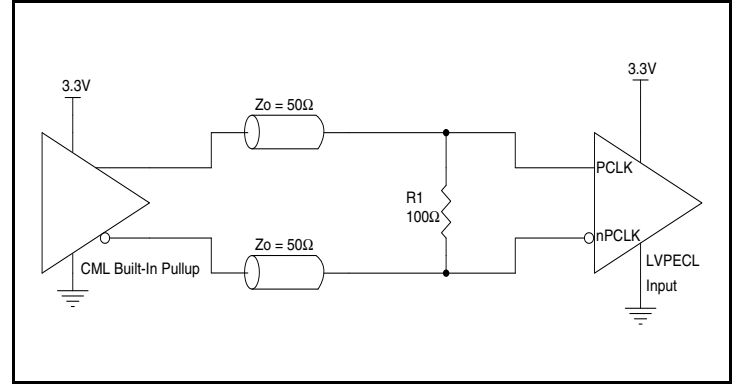

Figure 2B. PCLK/nPCLK Input Driven by a Built-In Pullup CML Driver

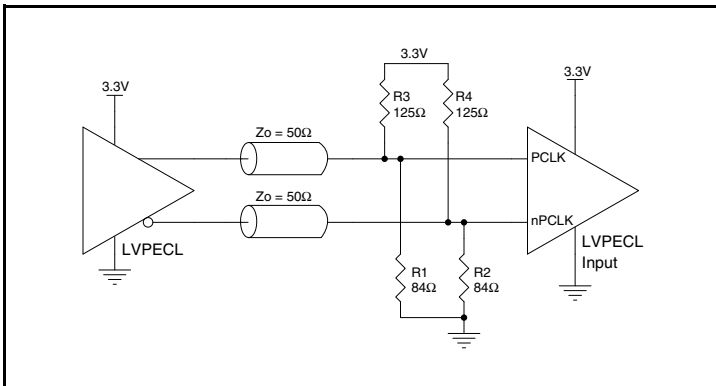

Figure 2C. PCLK/nPCLK Input Driven by a 3.3V LVPECL Driver

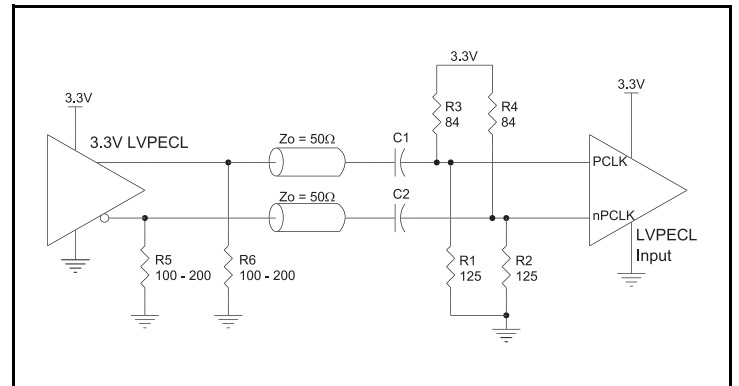

Figure 2D. PCLK/nPCLK Input Driven by a 3.3V LVPECL Driver with AC Couple

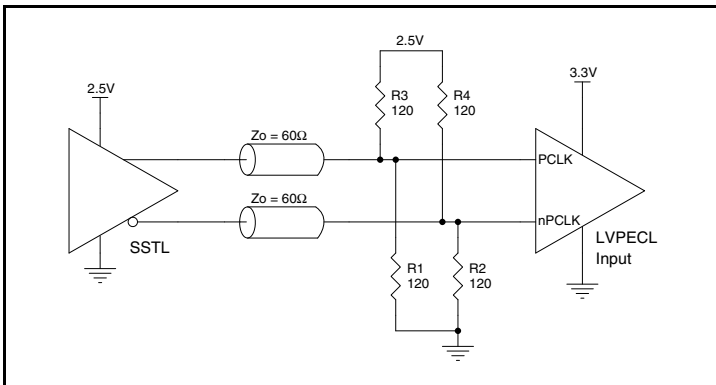

Figure 2E. PCLK/nPCLK Input Driven by an SSTL Driver

VFQFN EPAD Thermal Release Path

In order to maximize both the removal of heat from the package and the electrical performance, a land pattern must be incorporated on the Printed Circuit Board (PCB) within the footprint of the package corresponding to the exposed metal pad or exposed heat slug on the package, as shown in *Figure 3*. The solderable area on the PCB, as defined by the solder mask, should be at least the same size/shape as the exposed pad/slug area on the package to maximize the thermal/electrical performance. Sufficient clearance should be designed on the PCB between the outer edges of the land pattern and the inner edges of pad pattern for the leads to avoid any shorts.

While the land pattern on the PCB provides a means of heat transfer and electrical grounding from the package to the board through a solder joint, thermal vias are necessary to effectively conduct from the surface of the PCB to the ground plane(s). The land pattern must be connected to ground through these vias. The vias act as “heat pipes”. The number of vias (i.e. “heat pipes”) are application specific

and dependent upon the package power dissipation as well as electrical conductivity requirements. Thus, thermal and electrical analysis and/or testing are recommended to determine the minimum number needed. Maximum thermal and electrical performance is achieved when an array of vias is incorporated in the land pattern. It is recommended to use as many vias connected to ground as possible. It is also recommended that the via diameter should be 12 to 13mils (0.30 to 0.33mm) with 1oz copper via barrel plating. This is desirable to avoid any solder wicking inside the via during the soldering process which may result in voids in solder between the exposed pad/slug and the thermal land. Precautions should be taken to eliminate any solder voids between the exposed heat slug and the land pattern. Note: These recommendations are to be used as a guideline only. For further information, please refer to the Application Note on the Surface Mount Assembly of Amkor’s Thermally/Electrically Enhance Leadframe Base Package, Amkor Technology.

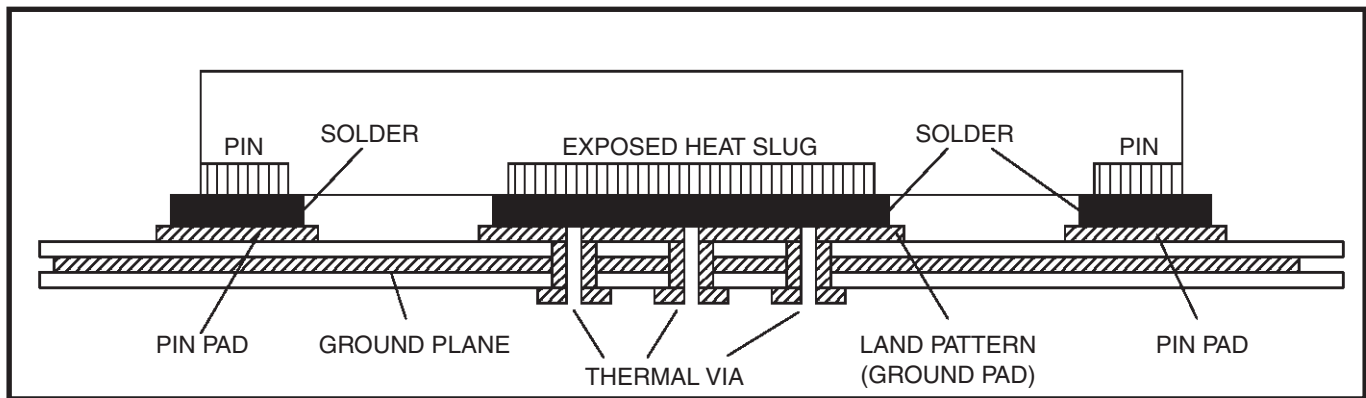

Figure 3. P.C. Assembly for Exposed Pad Thermal Release Path – Side View (drawing not to scale)

Recommendations for Unused Input and Output Pins

Inputs:

PCLK/nPCLK Inputs

For applications not requiring the use of the differential input, both PCLK and nPCLK can be left floating. Though not required, but for additional protection, a 1k Ω resistor can be tied from PCLK to ground.

LVCMOS_CLK Input

For applications not requiring the use of a clock input, it can be left floating. Though not required, but for additional protection, a 1k Ω resistor can be tied from the LVCMOS_CLK input to ground.

LVCMOS Control Pins

All control pins have internal pullups or pulldowns; additional resistance is not required but can be added for additional protection. A 1k Ω resistor can be used.

Outputs:

LVCMOS Outputs

All unused LVCMOS output can be left floating. There should be no trace attached.

Reliability Information

Table 6A. θ_{JA} vs. Air Flow Table for a 32 Lead LQFP

θ_{JA} vs. Air Flow			
Linear Feet per Minute	0	200	500
Multi-Layer PCB, JEDEC Standard Test Boards	47.9°C/W	42.1°C/W	39.4°C/W

Table 6B. θ_{JA} vs. Air Flow Table for a 32 Lead VFQFN

θ_{JA} vs. Air Flow			
Meters per Second	0	1	2.5
Multi-Layer PCB, JEDEC Standard Test Boards	40.2°C/W	35.1°C/W	31.5°C/W

Transistor Count

The transistor count for ICS83940DI is: 820

Package Outline and Package Dimensions

Package Outline - Y Suffix for 32 Lead LQFP

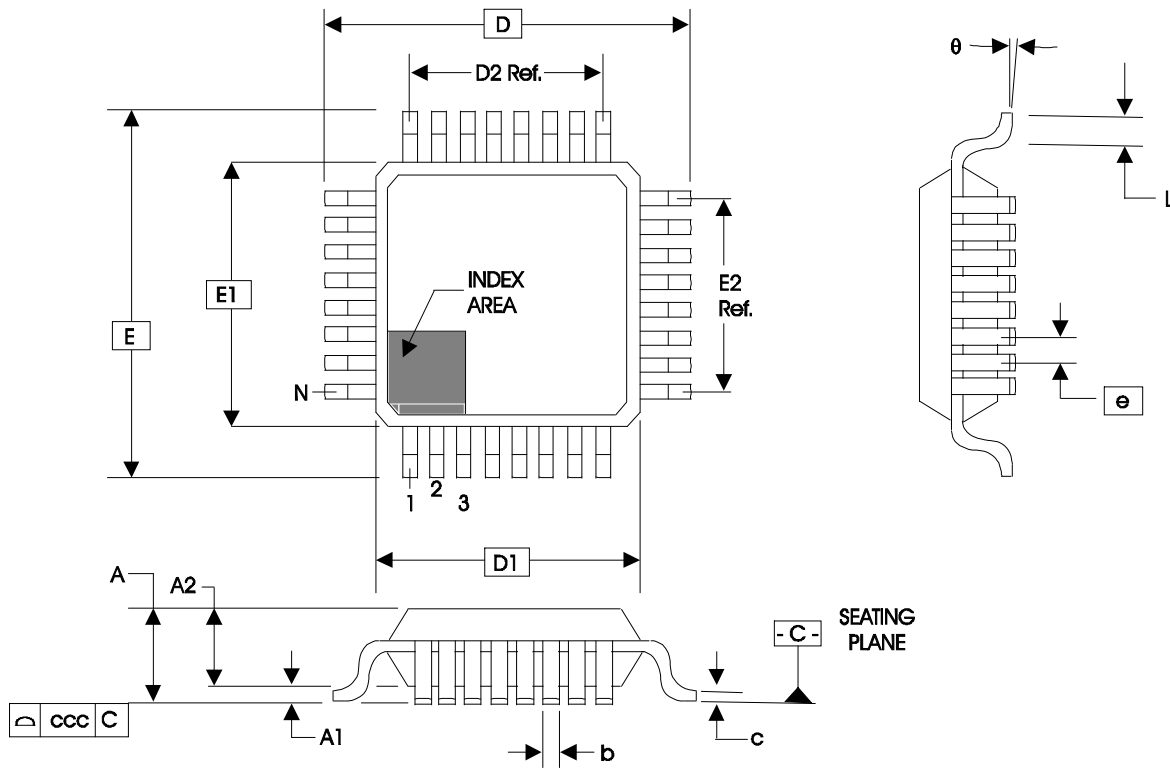

Table 7A. Package Dimensions for 32 Lead LQFP

JEDEC Variation: ABC - HD			
All Dimensions in Millimeters			
Symbol	Minimum	Nominal	Maximum
N	32		
A			1.60
A1	0.05	0.10	0.15
A2	1.35	1.40	1.45
b	0.30	0.37	0.45
c	0.09		0.20
D & E	9.00 Basic		
D1 & E1	7.00 Basic		
D2 & E2	5.60 Ref.		
e	0.80 Basic		
L	0.45	0.60	0.75
θ	0°		7°
ccc			0.10

Reference Document: JEDEC Publication 95, MS-026

Package Outline and Package Dimensions

Package Outline - K Suffix for 32 Lead VFQFN

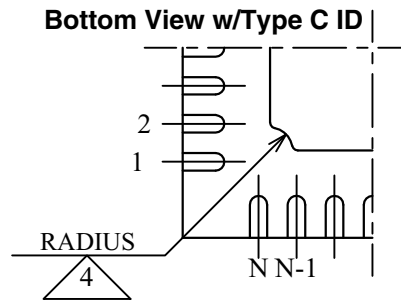
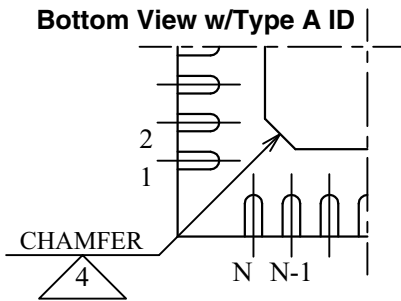
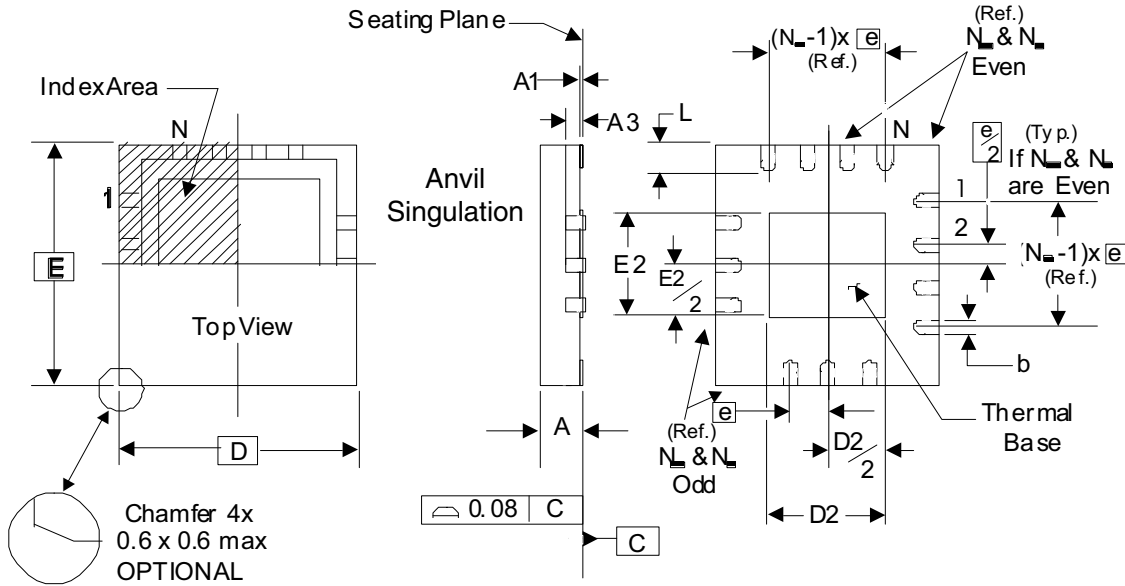

There are 2 methods of indicating pin 1 corner at the back of the VFQFN package:

1. Type A: Chamfer on the paddle (near pin 1)
2. Type C: Mouse bite on the paddle (near pin 1)

Table 7B. Package Dimensions

JEDEC Variation: VHHD-2/-4			
All Dimensions in Millimeters			
Symbol	Minimum	Nominal	Maximum
N		32	
A	0.80		1.00
A1	0		0.05
A3		0.25 Ref.	
b	0.18	0.25	0.30
N _D & N _E			8
D & E		5.00 Basic	
D2 & E2	3.0		3.3
e		0.50 Basic	
L	0.30	0.40	0.50

Reference Document: JEDEC Publication 95, MO-220

NOTE: The following package mechanical drawing is a generic drawing that applies to any pin count VFQFN package. This drawing is not intended to convey the actual pin count or pin layout of this device. The pin count and pinout are shown on the front page. The package dimensions are in Table 7B.

Ordering Information

Table 8. Ordering Information

Part/Order Number	Marking	Package	Shipping Packaging	Temperature
83940DYILF	ICS83940DYIL	"Lead-Free" 32 Lead LQFP	Tray	-40°C to 85°C
83940DYILFT	ICS83940DYIL	"Lead-Free" 32 Lead LQFP	Tape & Reel	-40°C to 85°C
83940DKILF	ICS83940DIL	"Lead-Free" 32 Lead VFQFN	Tray	-40°C to 85°C
83940DKILFT	ICS83940DIL	"Lead-Free" 32 Lead VFQFN	Tape & Reel	-40°C to 85°C

Revision History Sheet

Rev	Table	Page	Description of Change	Date
A	T2	2 7	Pin Characteristics table - changed R_{OUT} 25 Ω maximum to 28 Ω maximum. Delete R_{PULLUP} row. 3.3V Output Load AC Test Circuit diagram - corrected GND equation to read -1.65V... from -1.165V... Added LVTTL to title. Updated format.	12/12/02
A	T8	1 9 10 13	Features Section - added Lead-Free bullet. Application Information Section - added Recommendations for Unused Input and Output Pins. Application Information Section - added LVPECL Clock Input Interface. Ordering Information Table - added Lead-Free part number, marking, and note. Updated datasheet format.	11/27/06
A		3	Absolute Maximum Ratings - corrected Storage Temperature from "-40°C to 125°C" to "-65°C to 150°C".	2/21/07
B	T6B T7B T8	1 13 14 16 17	Added 32 Lead VFQFN Pin Assignment. Added <i>VFQFN Thermal Release Path</i> section. Added 32 VFQFN Thermal Table. Added 32 Lead VFQFN Package and Dimensions Table. Ordering Information Table - added 32 Lead VFQFN ordering information. Converted datasheet format.	8/13/09
C	T2	2 11 16	Pin Characteristics Table - R_{OUT} error, typical spec deleted. Updated Wiring the Differential Input to Accept Single-Ended Levels. Updated 32 VFQFN Package Outline.	9/7/10
C	T8	17	Removed leaded orderables from Ordering Information table	11/27/12
C		1, 14,16	Deleted "PROPOSED" stamp	3/20/13
C			Product Discontinuation Notice - Last time buy expires May 6, 2017. (83940DKILF) PDN CQ-16-01	5/19/16

We've Got Your Timing Solution



6024 Silver Creek Valley Road
San Jose, California 95138

Sales
800-345-7015 (inside USA)
+408-284-8200 (outside USA)
Fax: 408-284-2775
www.IDT.com/go/contactIDT

Technical Support Sales
clocks@idt.com
+480-763-2056

DISCLAIMER Integrated Device Technology, Inc. (IDT) and its subsidiaries reserve the right to modify the products and/or specifications described herein at any time and at IDT's sole discretion. All information in this document, including descriptions of product features and performance, is subject to change without notice. Performance specifications and the operating parameters of the described products are determined in the independent state and are not guaranteed to perform the same way when installed in customer products. The information contained herein is provided without representation or warranty of any kind, whether express or implied, including, but not limited to, the suitability of IDT's products for any particular purpose, an implied warranty of merchantability, or non-infringement of the intellectual property rights of others. This document is presented only as a guide and does not convey any license under intellectual property rights of IDT or any third parties.

IDT's products are not intended for use in applications involving extreme environmental conditions or in life support systems or similar devices where the failure or malfunction of an IDT product can be reasonably expected to significantly affect the health or safety of users. Anyone using an IDT product in such a manner does so at their own risk, absent an express, written agreement by IDT.

Integrated Device Technology, IDT and the IDT logo are registered trademarks of IDT. Other trademarks and service marks used herein, including protected names, logos and designs, are the property of IDT or their respective third party owners.

Copyright 2016. All rights reserved.

Компания «Life Electronics» занимается поставками электронных компонентов импортного и отечественного производства от производителей и со складов крупных дистрибьюторов Европы, Америки и Азии.

С конца 2013 года компания активно расширяет линейку поставок компонентов по направлению коаксиальный кабель, кварцевые генераторы и конденсаторы (керамические, пленочные, электролитические), за счёт заключения дистрибьюторских договоров

Мы предлагаем:

- Конкуренспособные цены и скидки постоянным клиентам.
- Специальные условия для постоянных клиентов.
- Подбор аналогов.
- Поставку компонентов в любых объемах, удовлетворяющих вашим потребностям.
- Приемлемые сроки поставки, возможна ускоренная поставка.
- Доставку товара в любую точку России и стран СНГ.
- Комплексную поставку.
- Работу по проектам и поставку образцов.
- Формирование склада под заказчика.
- Сертификаты соответствия на поставляемую продукцию (по желанию клиента).
- Тестирование поставляемой продукции.
- Поставку компонентов, требующих военную и космическую приемку.
- Входной контроль качества.
- Наличие сертификата ISO.

В составе нашей компании организован Конструкторский отдел, призванный помогать разработчикам, и инженерам.

Конструкторский отдел помогает осуществить:

- Регистрацию проекта у производителя компонентов.
- Техническую поддержку проекта.
- Защиту от снятия компонента с производства.
- Оценку стоимости проекта по компонентам.
- Изготовление тестовой платы монтаж и пусконаладочные работы.



Тел: +7 (812) 336 43 04 (многоканальный)

Email: org@lifeelectronics.ru