

Ultra-small Tactile Switch B3U

Ultra-small-sized Tactile Switch with High Contact Reliability: 1.2 x 3 x 2.5 mm (H x W x D)

- Industry's smallest switch* allows high-density mounting on PCBs for mobile equipment.
*As of October 2006 (according to OMRON survey).
- Dust-proof construction provides high reliability in dusty environments.
- Surface mounted: Ideal for high-density mounting.
- Models with ground terminals are available for protection against static electricity.
- RoHS Compliant

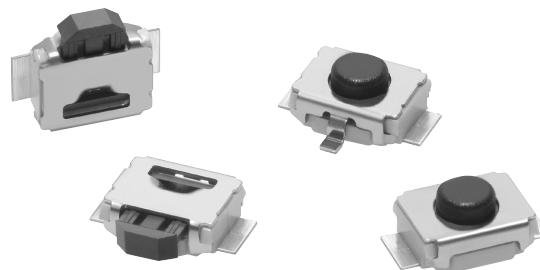

NEW

Ordering Information

| Type | Quantity per reel | Locating pin | Model | |
|---------------|-------------------|--------------|-------------------------|----------------------|
| | | | Without ground terminal | With ground terminal |
| Top-actuated | 3,500 pieces | Without boss | B3U-1000P | B3U-1100P |
| | | With boss | B3U-1000P-B | B3U-1100P-B |
| Side-actuated | 4,000 pieces | Without boss | B3U-3000P | B3U-3100P |
| | | With boss | B3U-3000P-B | B3U-3100P-B |

- Note:** 1. Order in multiples of the quantities given for each package
2. Replace "P" in the part number with "PM" to order versions with 1,000 pieces per reel. Example: B3U-3100PM-B

Specifications

■ Characteristics

| Item | Top-actuated (B3U-1000 Series) | Side-actuated (B3U-3000 Series) |
|-------------------------------|---|------------------------------------|
| Contact form | SPST-NO | |
| Switching capacity | 1 to 50 mA, 5 to 12 VDC (resistive load) | |
| Contact resistance | 100 mΩ max. (rated: 1 mA, 5 VDC) | |
| Insulation resistance | 100 MΩ min. (at 100 VDC) | |
| Dielectric strength | 250 VAC, 50/60 Hz for 1 min | |
| Bounce time | 5 ms max. | |
| Vibration resistance | 10 to 55 Hz, 1.5 mm double amplitude | |
| Shock resistance | 1,000 m/s ² max. | |
| Life expectancy | 200,000 operations min. | 100,000 operations min. |
| Ambient operating temperature | -25 to 70°C, (at 60% RH max.) with no icing or condensation | |
| Ambient operating humidity | 35% to 85% (at 5 to 35°C) | |
| Weight | Approx. 0.022 g | |

Note: Data shown are of initial value

■ Operating Characteristics

| Characteristics | Top-actuated (B3U-1000 Series) | Side-actuated (B3U-3000 Series) |
|---------------------------|---|--|
| Operating force (OF) | 153 ± 50 gf | 162 ± 50 gf |
| Releasing force (RF) min. | 20.3 gf | |
| Pretravel (PT) | 0.15 ^{+0.2} _{-0.1} mm | 0.2 ^{+0.2} _{-0.1} mm |

Dimensions

Note: All dimensions are in millimeters unless otherwise indicated. Unless otherwise specified, a tolerance of ± 0.2 mm applies to all dimensions.

■ Top-actuated Models

Without Ground Terminal, without Boss B3U-1000P

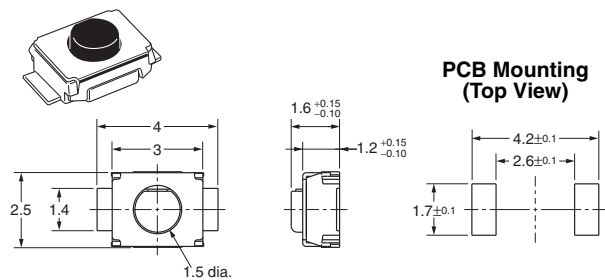

With Ground Terminal, without Boss B3U-1100P

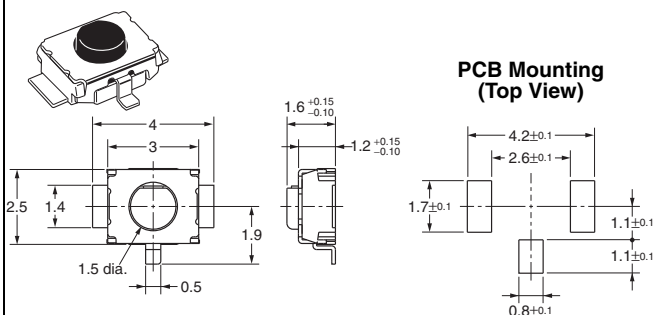

Without Ground Terminal, with Boss B3U-1000P-B

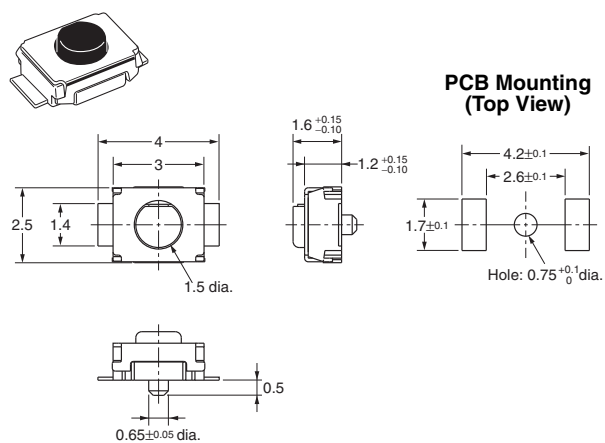

With Ground Terminal, with Boss B3U-1100P-B

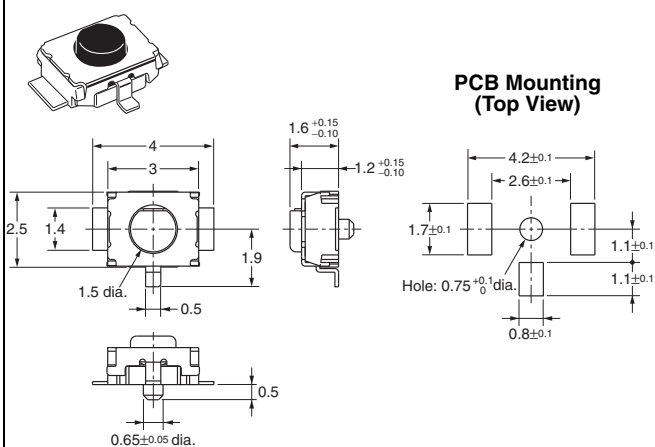

Side-actuated Models

Note: All dimensions are in millimeters unless otherwise indicated. Unless otherwise specified, a tolerance of ± 0.2 mm applies to all dimensions.

Without Ground Terminal, without Boss

B3U-3000P

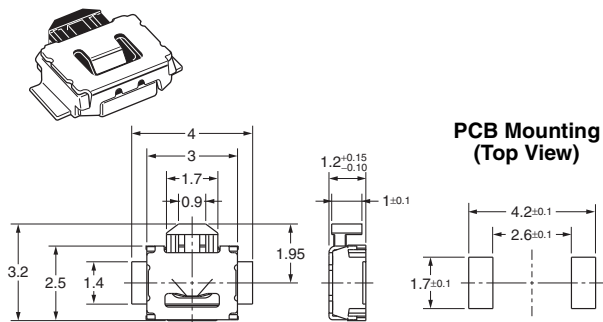

With Ground Terminal, without Boss

B3U-3100P

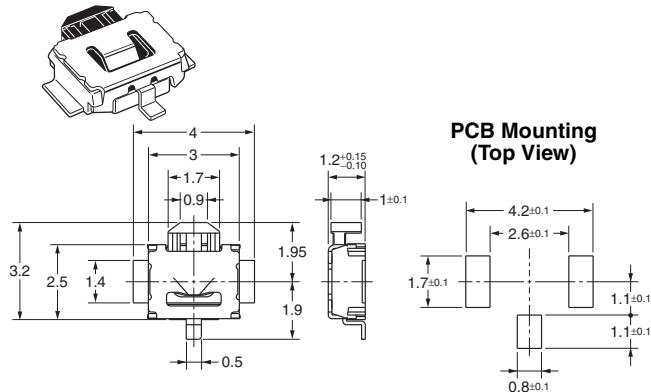

Without Ground Terminal, with Boss

B3U-3000P-B

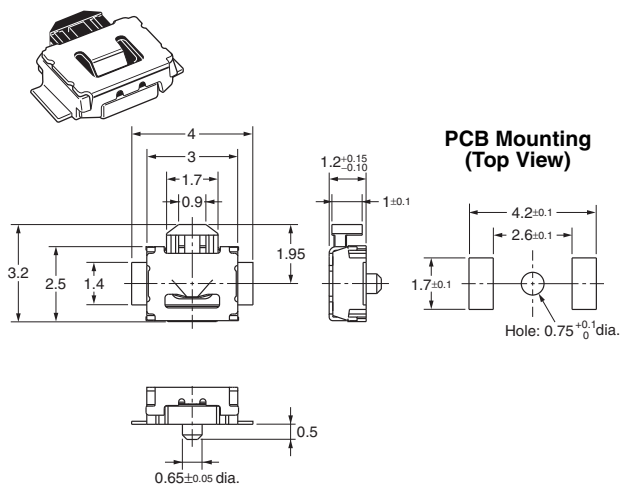

With Ground Terminal, with Boss

B3U-3100P-B

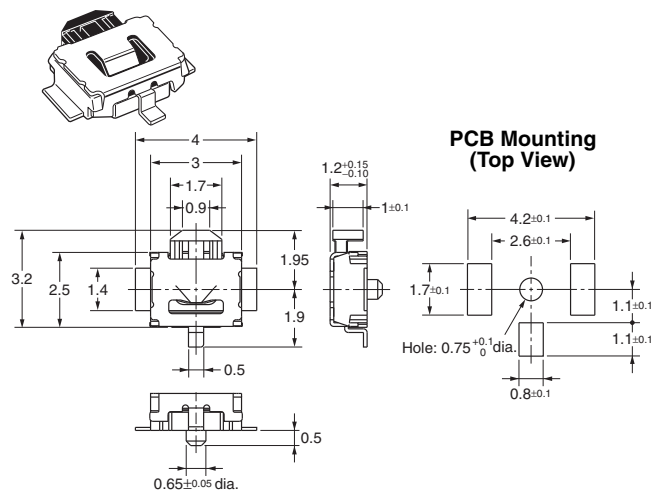

Precautions

Be sure to read the precautions common to all Tactile Switches, contained in the Technical User's Guide, "Tactile Switches, Technical Information" for correct use.

■ Precautions for Correct Use

Soldering

Perform reflow soldering within the ranges shown in the terminal temperature profile in the following diagram.

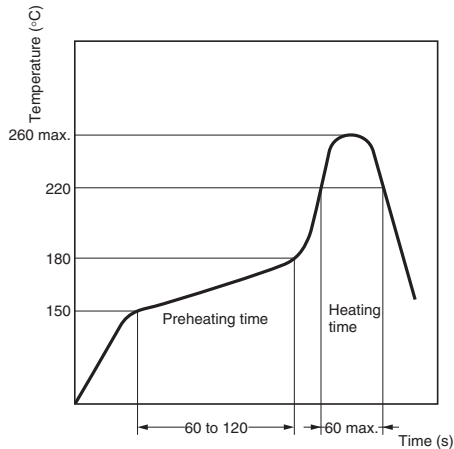

Washing

B3U Switches cannot be washed. Doing so will cause the washing agent, together with flux or dust particles on the PCB, to enter the Switch, resulting in malfunction.

Compliance with RoHS Directive

The "RoHS Compliant" designation indicates that the product does not contain the following six hazardous substances covered by the RoHS Directive.

Reference: The following standards are used to determine compliance for the six substances.

- Lead: 1,000 ppm max.
- Mercury: 1,000 ppm max.
- Cadmium: 100 ppm max.
- Hexavalent chromium: 1,000 ppm max.
- PBB: 1,000 ppm max.
- PBDE: 1,000 ppm max.

Storage and Operating Environment

Do not store the product under the following conditions to prevent discoloration and other deterioration of the terminals.

1. Locations subject to high temperatures or humidity
2. Locations containing corrosive gases
3. Locations subject to direct sunlight

The Switch is not provided with a watertight or drip-proof construction. Do not install or operate the product in locations subject to water spray or splashes.

Packaging Specifications

The specifications for B3U Switches packaged on embossed tape are as follows:

B3U-1000 Series

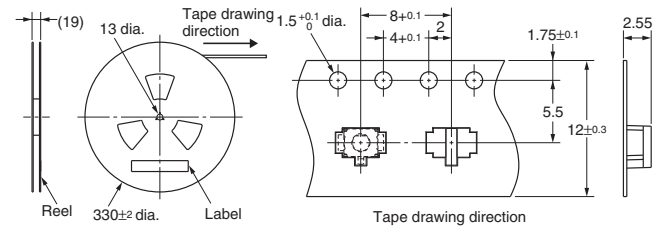

B3U-3000 Series

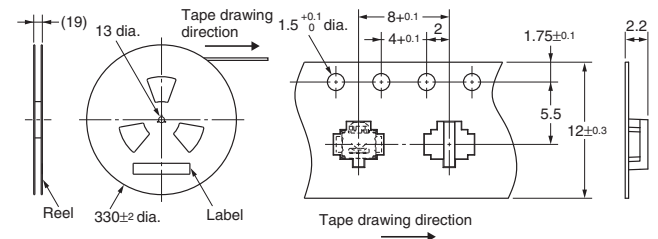

| | |
|------------------------|--|
| Standards | Conforms to JEITA. |
| Package | 3,500 Switches (B3U-1000 Series) 4,000 Switches (B3U-3000 Series) |
| Heat resistance | 50°C for 24 hours (without deformation) |

Operation

Do not repeatedly operate the Switch with excessive force. Applying excessive pressure or applying additional force after the plunger has stopped may deform the disc spring of the Switch, resulting in malfunction. (Maximum force = 30N)

Be sure to set up the Switch so that the plunger will be pressed straight in. The life of the Switch may be reduced if the plunger is pressed off-center or from an angle. Do not apply pressure from above or below the plunger. Doing so may deform or damage parts or cause faulty operation.

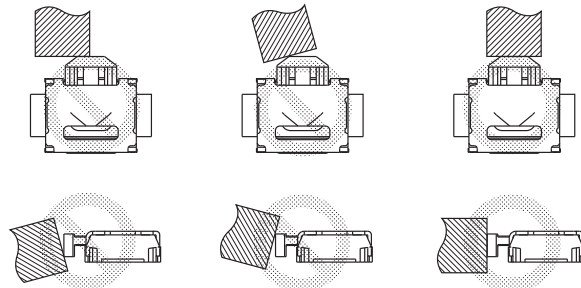

Do not operate the plunger from the side. Doing so may deform or damage the Switch.

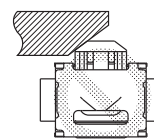



All sales are subject to Omron Electronic Components LLC standard terms and conditions of sale, which can be found at http://www.components.omron.com/components/web/webfiles.nsf/sales_terms.html

ALL DIMENSIONS SHOWN ARE IN MILLIMETERS.
To convert millimeters into inches, multiply by 0.03937. To convert grams into ounces, multiply by 0.03527.

OMRON[®]

**OMRON ELECTRONIC
COMPONENTS LLC**

55 E. Commerce Drive, Suite B
Schaumburg, IL 60173

847-882-2288

OMRON ON-LINE

Global - <http://www.omron.com>

USA - <http://www.components.omron.com>

Компания «Life Electronics» занимается поставками электронных компонентов импортного и отечественного производства от производителей и со складов крупных дистрибьюторов Европы, Америки и Азии.

С конца 2013 года компания активно расширяет линейку поставок компонентов по направлению коаксиальный кабель, кварцевые генераторы и конденсаторы (керамические, пленочные, электролитические), за счёт заключения дистрибьюторских договоров

Мы предлагаем:

- Конкурентоспособные цены и скидки постоянным клиентам.
- Специальные условия для постоянных клиентов.
- Подбор аналогов.
- Поставку компонентов в любых объемах, удовлетворяющих вашим потребностям.
- Приемлемые сроки поставки, возможна ускоренная поставка.
- Доставку товара в любую точку России и стран СНГ.
- Комплексную поставку.
- Работу по проектам и поставку образцов.
- Формирование склада под заказчика.
- Сертификаты соответствия на поставляемую продукцию (по желанию клиента).
- Тестирование поставляемой продукции.
- Поставку компонентов, требующих военную и космическую приемку.
- Входной контроль качества.
- Наличие сертификата ISO.

В составе нашей компании организован Конструкторский отдел, призванный помогать разработчикам, и инженерам.

Конструкторский отдел помогает осуществить:

- Регистрацию проекта у производителя компонентов.
- Техническую поддержку проекта.
- Защиту от снятия компонента с производства.
- Оценку стоимости проекта по компонентам.
- Изготовление тестовой платы монтаж и пусконаладочные работы.



Тел: +7 (812) 336 43 04 (многоканальный)

Email: org@lifeelectronics.ru