

xDSL/Cable Modem Triple/Quintuple Output Power Supplies

General Description

The MAX1864/MAX1865 power-supply controllers are designed to address cost-conscious applications such as cable modem Consumer Premise Equipment (CPE), xDSL CPE, and set-top boxes. Operating off a low-cost, unregulated DC supply (such as a wall adapter output), the MAX1864 generates three positive outputs, and the MAX1865 generates four positive outputs and one negative output to provide a cost-effective system power supply.

The MAX1864 includes a current-mode synchronous step-down controller and two positive regulator gain blocks. The MAX1865 has one additional positive gain block and one negative regulator gain block. The main synchronous step-down controller generates a high-current output that is preset to 3.3V or adjustable from 1.236V to $0.8 \times V_{IN}$ with an external resistive-divider. The 100kHz/200kHz operating frequency allows the use of low-cost aluminum-electrolytic capacitors and low-cost power magnetics. Additionally, the MAX1864/MAX1865 step-down controllers sense the voltage across the low-side MOSFET's on-resistance to efficiently provide the current-limit signal, eliminating the need for costly current-sense resistors.

The MAX1864/MAX1865 generate additional supply rails at low cost. The positive regulator gain blocks use an external PNP pass transistor to generate low-voltage rails directly from the main step-down converter (such as 2.5V or 1.8V from the main 3.3V output) or higher voltages using coupled windings from the step-down converter (such as 5V, 12V, or 15V). The MAX1865's negative gain block uses an external NPN pass transistor in conjunction with a coupled winding to generate -5V, -12V, or -15V.

All output voltages are externally adjustable, providing maximum flexibility. Additionally, the MAX1864/MAX1865 feature soft-start for the step-down converter and all the positive linear regulators, and have a power-good output that monitors all of the output voltages.

Applications

xDSL, Cable, and ISDN Modems
Set-Top Boxes
Wireless Local Loop

Features

- ◆ 4.5V to 28V Input Voltage Range
- ◆ Master DC-DC Step-Down Converter
 - Preset 3.3V or Adjustable (1.236V to $0.8 \times V_{IN}$) Output Voltage
 - Fixed-Frequency (100kHz/200kHz) PWM Controller
 - No Current-Sense Resistor
 - Adjustable Current Limit
 - 95% Efficient
- ◆ Two (MAX1864)/Four (MAX1865) Analog Gain Blocks
 - Positive Analog Blocks Drive Low-Cost PNP Pass Transistors to Build Positive Linear Regulators
 - Negative Analog Block (MAX1865) Drives a Low-Cost NPN Pass Transistor to Build a Negative Linear Regulator
- ◆ Power-Good Indicator
- ◆ Soft-Start Ramp for All Positive Regulators

Ordering Information

PART	TEMP. RANGE	PIN-PACKAGE	fosc (kHz)
MAX1864TEEE	-40°C to +85°C	16 QSOP	200
MAX1864UEEE	-40°C to +85°C	16 QSOP	100
MAX1865TEEP	-40°C to +85°C	20 QSOP	200
MAX1865UEEP	-40°C to +85°C	20 QSOP	100

Pin Configurations

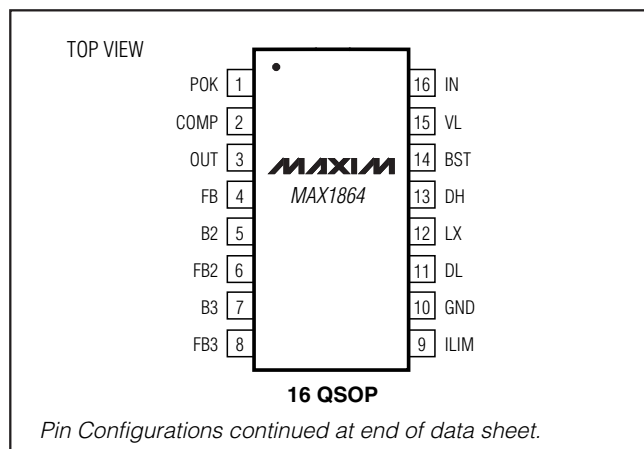

xDSL/Cable Modem Triple/Quintuple Output Power Supplies

ABSOLUTE MAXIMUM RATINGS

IN, B2, B3, B4 to GND.....	-0.3V to +30V
B5 to OUT.....	-20V to +0.3V
VL, POK, FB, FB2, FB3, FB4, FB5 to GND.....	-0.3V to +6V
LX to BST.....	-6V to +0.3V
BST to GND.....	-0.3V to +36V
DH to LX.....	-0.3V to (V _{BST} + 0.3V)
DL, OUT, COMP, ILIM to GND.....	-0.3V to (V _L + 0.3V)
VL Output Current.....	50mA
VL Short Circuit to GND.....	≤100ms

Continuous Power Dissipation (T _A = +70°C)	
16-Pin QSOP (derate 8.3mW/°C above +70°C).....	666mW
20-Pin QSOP (derate 9.1mW/°C above +70°C).....	727mW
Operating Temperature Range.....	-40°C to +85°C
Junction Temperature.....	+150°C
Storage Temperature Range.....	-65°C to +150°C
Lead Temperature (soldering, 10s).....	+300°C

Stresses beyond those listed under "Absolute Maximum Ratings" may cause permanent damage to the device. These are stress ratings only, and functional operation of the device at these or any other conditions beyond those indicated in the operational sections of the specifications is not implied. Exposure to absolute maximum rating conditions for extended periods may affect device reliability.

ELECTRICAL CHARACTERISTICS

(V_{IN} = 12V, ILIM = FB = GND, V_{BST} - V_{LX} = 5V, T_A = 0°C to +85°C. Typical values are at T_A = +25°C, unless otherwise noted.)

PARAMETER	SYMBOL	CONDITIONS	MIN	TYP	MAX	UNITS
GENERAL						
Operating Input Voltage Range (Note 1)	V _{IN}		4.5		28	V
Quiescent Supply Current	I _{IN}	V _{FB} = 0, V _{OUT} = 4V, V _{FB2} = V _{FB3} = V _{FB4} = 1.5V, V _{FB5} = -0.1V	MAX1864	1.0	2	mA
			MAX1865	1.4	3	
VL REGULATOR						
Output Voltage	VL	6V < V _{IN} < 28V, 0.1mA < I _{LOAD} < 20mA	4.75	5.00	5.25	V
Power-Supply Rejection	PSRR	V _{IN} = 6V to 28V			3	%
Undervoltage Lockout Trip Level	V _{UVLO}	VL rising, 3% hysteresis (typ)	3.2	3.5	3.8	V
Minimum Bypass Capacitance	C _{BYP(MIN)}	10mΩ < ESR < 500mΩ		1		μF
DC-DC CONTROLLER						
Output Voltage (Preset Mode)	V _{OUT}	FB = GND	3.272	3.314	3.355	V
Typical Output Voltage Range (Adjustable Mode) (Note 2)	V _{OUT}		1.236		0.8 × V _{IN}	V
FB Set Voltage (Adjustable Mode)	V _{SET}	FB = COMP	1.221	1.236	1.252	V
FB Dual Mode™ Threshold			50	100	150	mV
FB Input Leakage Current	I _{FB}	V _{FB} = 1.5V		0.01	100	nA
FB to COMP Transconductance	g _m	FB = COMP, I _{COMP} = ±5μA	70	100	140	μS
Current-Sense Amplifier Voltage Gain	A _{LIM}	V _{IN} - V _{LX} = 250mV	4.46	4.9	5.44	V/V
Current-Limit Threshold (Internal Mode)	V _{VALLEY}	V _{LIM} = 5.0V	190	250	310	mV
Current-Limit Threshold (External Mode)	V _{VALLEY}	V _{LIM} = 2.5V	440	530	620	mV

Dual Mode is a trademark of Maxim Integrated Products, Inc.

xDSL/Cable Modem Triple/Quintuple Output Power Supplies

MAX1864/MAX1865

ELECTRICAL CHARACTERISTICS (continued)

($V_{IN} = 12V$, $I_{LIM} = FB = GND$, $V_{BST} - V_{LX} = 5V$, $T_A = 0^{\circ}C$ to $+85^{\circ}C$. Typical values are at $T_A = +25^{\circ}C$, unless otherwise noted.)

PARAMETER	SYMBOL	CONDITIONS	MIN	TYP	MAX	UNITS
Switching Frequency	f_{OSC}	MAX186_T	160	200	240	kHz
		MAX186_U	80	100	120	
Maximum Duty Cycle	D_{MAX}		77	82	90	%
Soft-Start Period	t_{SOFT}			1024		1/ f_{OSC}
Soft-Start Steps				$V_{REF}/64$		V
DH Output Low Voltage		$I_{SINK} = 10mA$, measured from DH to LX			0.1	V
DH Output High Voltage		$I_{SOURCE} = 10mA$, measured from BST to DH	0.1			V
DL Output Low Voltage		$I_{SINK} = 10mA$, measured from DL to GND			0.1	V
DL Output High Voltage		$I_{SOURCE} = 10mA$, measured from DL to GND	$V_L - 0.1$			V
DH, DL On-Resistance				3	10	Ω
Output Drive Current		Sourcing or sinking, V_{DH} or $V_{DL} = V_L/2$		0.5		A
LX, BST Leakage Current		$V_{BST} = V_{LX} = V_{IN} = 28V$, $V_{FB} = 1.5V$		0.03	20	μA
POSITIVE ANALOG GAIN BLOCKS						
FB2, FB3, FB4 Regulation Voltage		$V_{B2} = V_{B3} = V_{B4} = 5V$, $I_{B2} = I_{B3} = I_{B4} = 1mA$ (sink)	1.226	1.240	1.257	V
FB2, FB3, FB4 to B ₋ Transconductance	ΔV_{FB-}	$V_{B2} = V_{B3} = V_{B4} = 5V$, $I_{B2} = I_{B3} = I_{B4} = 0.5mA$ to $5mA$ (sink)		-1	-1.75	%
Feedback Input Leakage Current	I_{FB-}	$V_{FB2} = V_{FB3} = V_{FB4} = 1.5V$		0.01	100	nA
Driver Sink Current	I_{B-}	$V_{FB2} = V_{FB3} = V_{FB4} = 1.188V$	10	$V_{B2} = V_{B3} = V_{B4} = 2.5V$	23	mA
				$V_{B2} = V_{B3} = V_{B4} = 4.0V$	26	
NEGATIVE ANALOG GAIN BLOCK						
FB5 Regulation Voltage		$V_{B5} = V_{OUT} - 2V$, $V_{OUT} = 3.5V$, $I_{B5} = 1mA$ (source)	-20	-5	+10	mV
FB5 to B5 Transconductance	ΔV_{FB5}	$V_{B5} = 0$, $I_{B5} = 0.5mA$ to $5mA$ (source)		-13	-20	mV
Feedback Input Leakage Current	I_{FB5}	$V_{FB5} = -100mV$		0.01	100	nA
Driver Source Current	I_{B5}	$V_{FB5} = 200mV$, $V_{B5} = V_{OUT} - 2.0V$, $V_{OUT} = 3.5V$	10	25		mA
POWER GOOD (POK)						
OUT Trip Level (Preset Mode)		$FB = GND$, falling edge, 1% hysteresis (typ)	2.88	3	3.12	V
FB Trip Level (Adjustable Mode)		Falling edge, 1% hysteresis (typ)	1.070	1.114	1.159	V
FB2, FB3, FB4 Trip Level		Falling edge, 1% hysteresis (typ)	1.070	1.114	1.159	V
FB5 Trip Level		Rising edge, 35mV hysteresis (typ)	368	500	632	mV
POK Output Low Level		$I_{SINK} = 1mA$			0.4	V
POK Output High Leakage		$V_{POK} = 5V$			1	μA
THERMAL PROTECTION (Note 3)						
Thermal Shutdown		Rising temperature		160		$^{\circ}C$
Thermal Shutdown Hysteresis				15		$^{\circ}C$

xDSL/Cable Modem Triple/Quintuple Output Power Supplies

ELECTRICAL CHARACTERISTICS

($V_{IN} = 12V$, $I_{LIM} = FB = GND$, $V_{BST} - V_{LX} = 5V$, $T_A = -40^{\circ}C$ to $+85^{\circ}C$, unless otherwise noted.) (Note 4)

PARAMETER	SYMBOL	CONDITIONS	MIN	MAX	UNITS
GENERAL					
Operating Input Voltage Range (Note 1)	V_{IN}		4.5	28	V
Quiescent Supply Current	I_{IN}	$V_{FB} = 0$, $V_{OUT} = 4V$, $V_{FB2} = V_{FB3} = V_{FB4} = 1.5V$, $V_{FB5} = -0.1V$	MAX1864	2	mA
			MAX1865	3	
VL REGULATOR					
Output Voltage	V_L	$6V < V_{IN} < 28V$, $0.1mA < I_{LOAD} < 20mA$	4.75	5.25	V
Power-Supply Rejection	PSRR	$V_{IN} = 6V$ to $28V$		3	%
Undervoltage Lockout Trip Level	V_{UVLO}	V_L rising, 3% hysteresis (typ)	3	4	V
DC-DC CONTROLLER					
Output Voltage (Preset Mode)	V_{OUT}	$FB = GND$	3.247	3.380	V
Feedback Set Voltage (Adjustable Mode)	V_{SET}	$FB = COMP$	1.211	1.261	V
Current-Sense Amplifier Voltage Gain	A_{LIM}	$V_{IN} - V_{LX} = 250mV$	4.12	5.68	V/V
Current-Limit Threshold (Internal Mode)	V_{VALLEY}	$V_{LIM} = 5V$	150	350	mV
Current-Limit Threshold (External Mode)	V_{VALLEY}	$V_{LIM} = 2.5V$	400	660	mV
Switching Frequency	f_{OSC}	MAX186_T	160	240	kHz
		MAX186_U	80	120	
Maximum Duty Cycle	D_{MAX}		74	90	%
POSITIVE ANALOG GAIN BLOCKS					
FB2, FB3, FB4 Regulation Voltage		$V_{B2} = V_{B3} = V_{B4} = 5V$, $I_{B2} = I_{B3} = I_{B4} = 1mA$ (sink)	1.215	1.265	V
FB2, FB3, FB4 to B ₋ Transconductance	ΔV_{FB-}	$V_{B2} = V_{B3} = V_{B4} = 5V$, $I_{B2} = I_{B3} = I_{B4} = 0.5mA$ to $5mA$ (sink)		-2.25	%
NEGATIVE ANALOG GAIN BLOCK					
FB5 Regulation Voltage		$V_{B5} = V_{OUT} - 2V$, $V_{OUT} = 3.5V$, $I_{B5} = 1mA$ (source)	-25	+10	mV
FB5 to B5 Transconductance	ΔV_{FB5}	$V_{B5} = 0$, $I_{B5} = 0.5mA$ to $5mA$ (source)		-30	mV

xDSL/Cable Modem Triple/Quintuple Output Power Supplies

MAX1864/MAX1865

ELECTRICAL CHARACTERISTICS (continued)

($V_{IN} = 12V$, $I_{LIM} = FB = GND$, $V_{BST} - V_{LX} = 5V$, $T_A = -40^{\circ}C$ to $+85^{\circ}C$, unless otherwise noted.) (Note 4)

PARAMETER	SYMBOL	CONDITIONS	MIN	MAX	UNITS
POWER GOOD (POK)					
OUT Trip Level (Preset Mode)		FB = GND, falling edge, 1% hysteresis (typ)	2.85	3.15	V
FB Trip Level (Adjustable Mode)		Falling edge, 1% hysteresis (typ)	1.058	1.17	V
FB2, FB3, FB4 Trip Level		Falling edge, 1% hysteresis (typ)	1.058	1.17	V
FB5 Trip Level		Rising edge, 35mV hysteresis (typ)	325	675	mV

Note 1: Connect VL to IN for operation with $V_{IN} < 5V$.

Note 2: See *Output Voltage Selection* section.

Note 3: The internal 5V linear regulator (VL) powers the thermal shutdown block. Shorting VL to GND disables thermal shutdown.

Note 4: Specifications to $-40^{\circ}C$ are guaranteed by design, not production tested.

Typical Operating Characteristics

(Circuit of Figure 1, $V_{IN} = 12V$, $V_{OUT} = 3.3V$, $T_A = +25^{\circ}C$, unless otherwise noted.)

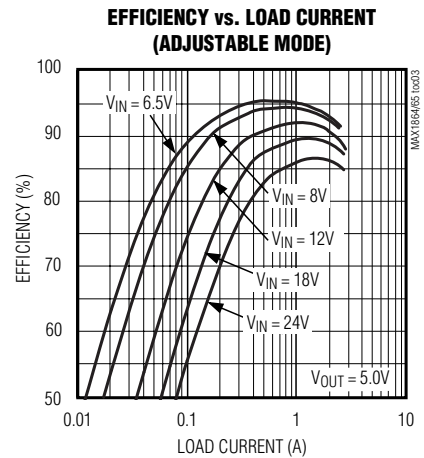
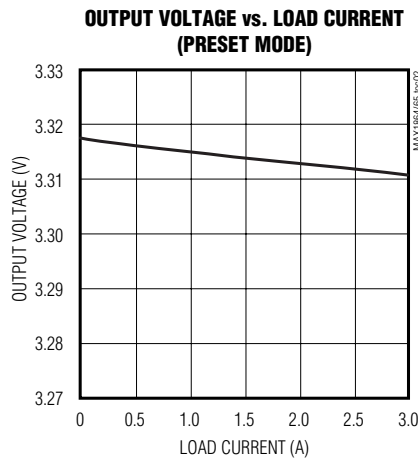
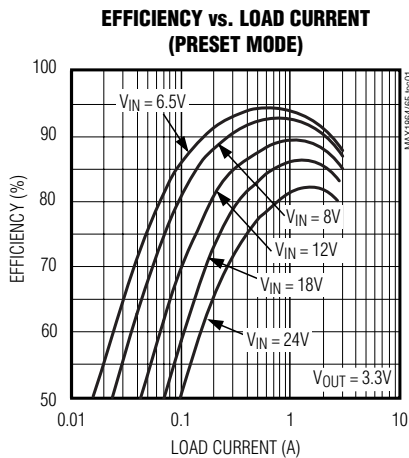

xDSL/Cable Modem Triple/Quintuple Output Power Supplies

Typical Operating Characteristics (continued)

(Circuit of Figure 1, $V_{IN} = 12V$, $V_{OUT} = 3.3V$, $T_A = +25^\circ C$, unless otherwise noted.)

OUTPUT VOLTAGE vs. LOAD CURRENT (ADJUSTABLE MODE)

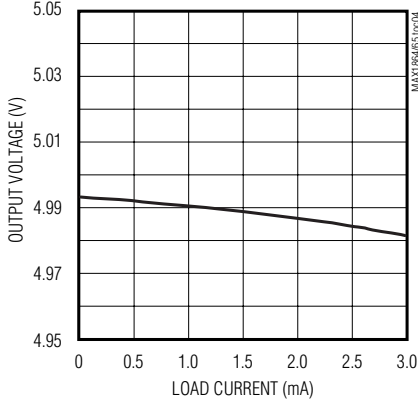

INTERNAL 5V LINEAR REGULATOR vs. LOAD CURRENT

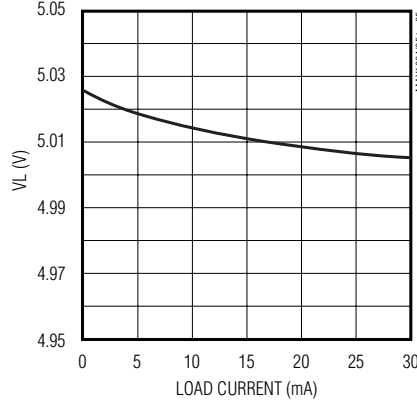

LOAD TRANSIENT (STEP-DOWN CONVERTER)

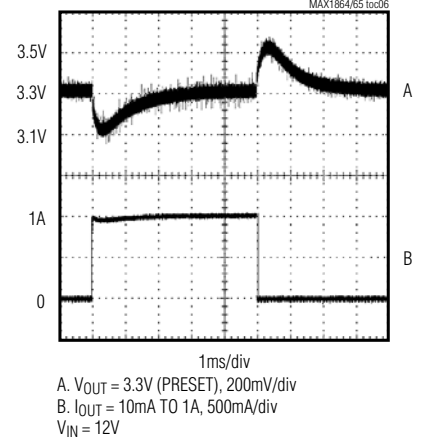

SWITCHING WAVEFORMS (STEP-DOWN CONVERTER)

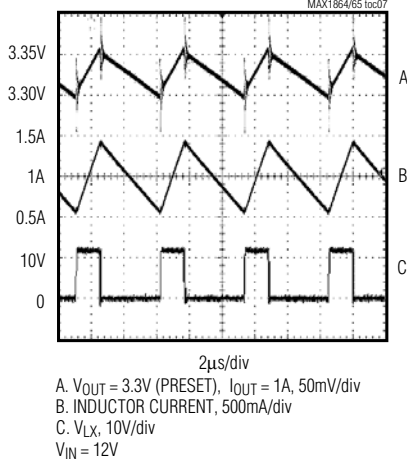

SOFT-START

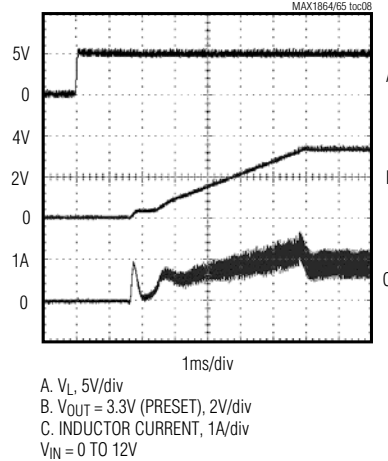

POSITIVE LINEAR REGULATOR BASE-DRIVE CURRENT vs. BASE-DRIVE VOLTAGE

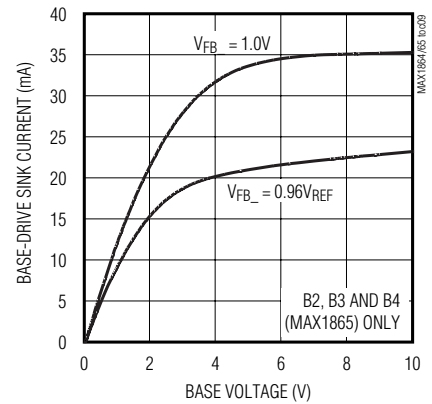

xDSL/Cable Modem Triple/Quintuple Output Power Supplies

Typical Operating Characteristics (continued)

(Circuit of Figure 1, $V_{IN} = 12V$, $V_{OUT} = 3.3V$, $T_A = +25^{\circ}C$, unless otherwise noted.)

MAX1864/MAX1865

**POSITIVE LINEAR REGULATOR
OUTPUT VOLTAGE vs. LOAD CURRENT
($Q_{LDO} = 2N3905$)**

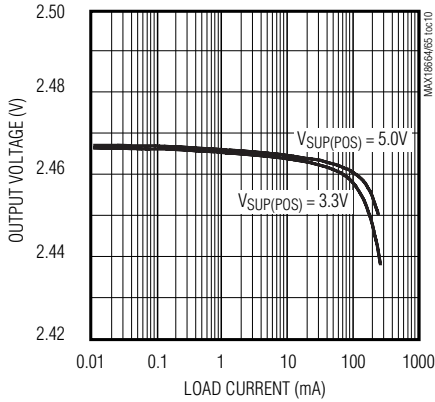

**POSITIVE LINEAR REGULATOR
OUTPUT VOLTAGE vs. SUPPLY VOLTAGE
($Q_{LDO} = 2N3905$)**

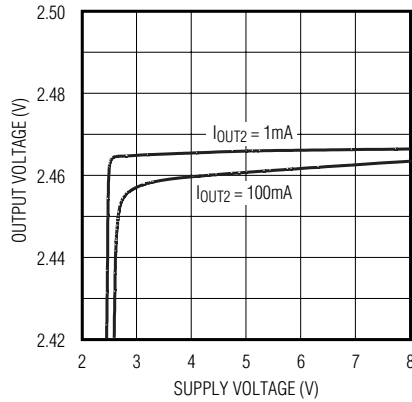

**POSITIVE LINEAR REGULATOR
POWER-SUPPLY REJECTION RATIO
($Q_{LDO} = 2N3905$)**

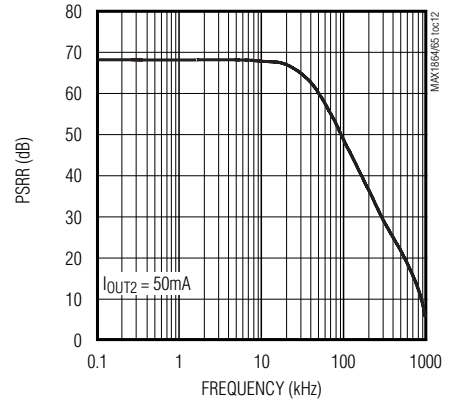

**POSITIVE LINEAR REGULATOR
LOAD TRANSIENT
($Q_{LDO} = 2W3905$)**

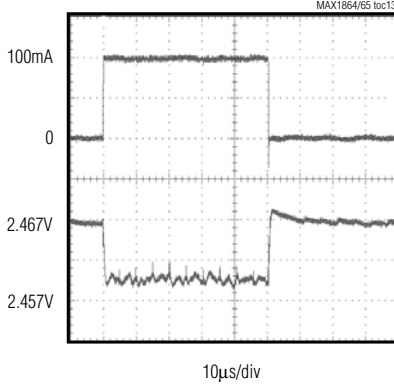

A. $I_{OUT2} = 1mA$ TO $100mA$, $50mA/div$
 B. $V_{OUT2} = 2.5V$, $5mV/div$
 $C_{LDO}(POS) = 10\mu F$ CERAMIC, $V_{SUP}(POS) = 3.3V$
 CIRCUIT OF FIGURE 1

**POSITIVE LINEAR REGULATOR
OUTPUT VOLTAGE vs. LOAD CURRENT
($Q_{LDO} = TIP30$)**

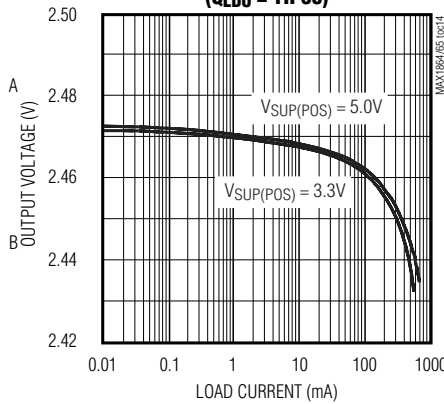

**POSITIVE LINEAR REGULATOR
OUTPUT VOLTAGE vs. SUPPLY VOLTAGE
($Q_{LDO} = TIP30$)**

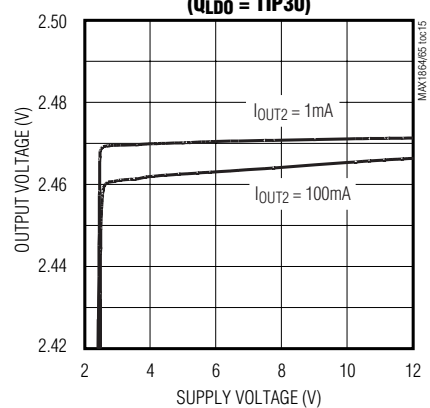

xDSL/Cable Modem Triple/Quintuple Output Power Supplies

Typical Operating Characteristics (continued)

(Circuit of Figure 1, $V_{IN} = 12V$, $V_{OUT} = 3.3V$, $T_A = +25^\circ C$, unless otherwise noted.)

**POSITIVE LINEAR REGULATOR
POWER-SUPPLY REJECTION RATIO
($Q_{LDO} = TIP30$)**

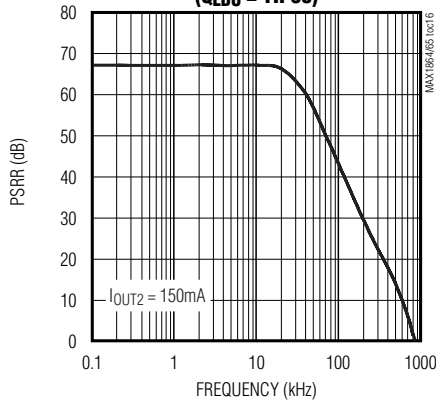

**POSITIVE LINEAR REGULATOR
LOAD TRANSIENT
($Q_{LDO} = TIP30$)**

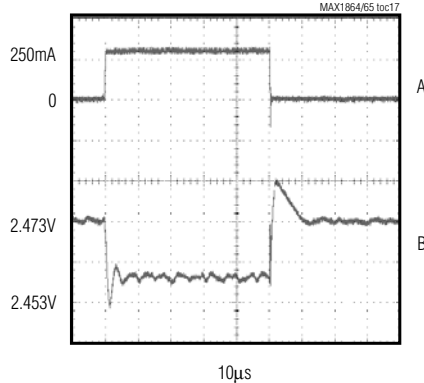

A. $I_{OUT2} = 10mA$ TO $250mA$, $200mA/div$
 B. $V_{OUT2} = 2.5V$, $10mV/div$
 $C_{LDO(POS)} = 10\mu F$ CERAMIC, $V_{SUP(POS)} = 3.3V$
 CIRCUIT OF FIGURE 1

**NEGATIVE LINEAR REGULATOR BASE-
DRIVE CURRENT vs. BASE-DRIVE VOLTAGE**

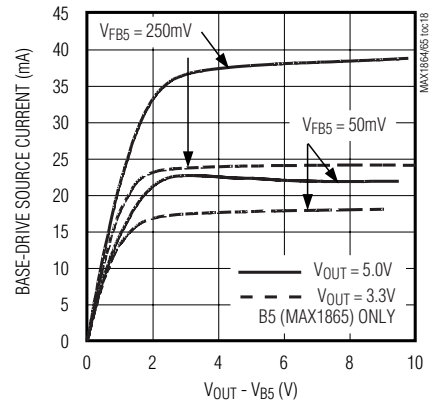

**NEGATIVE LINEAR REGULATOR
OUTPUT VOLTAGE vs. LOAD CURRENT
($Q_{LDO} = TIP29$)**

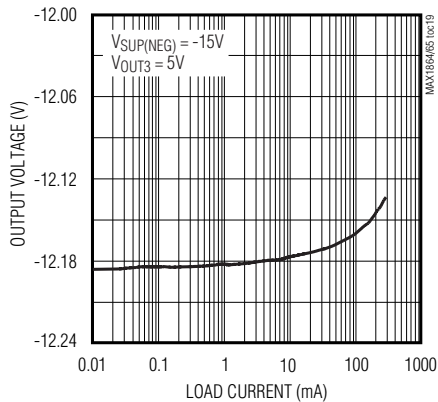

**NEGATIVE LINEAR REGULATOR
OUTPUT VOLTAGE vs. SUPPLY VOLTAGE
($Q_{LDO} = TIP29$)**

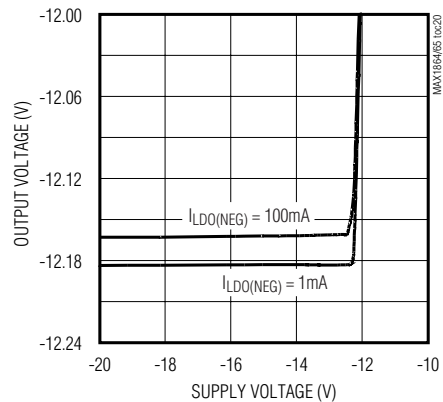

xDSL/Cable Modem Triple/Quintuple Output Power Supplies

Pin Description

MAX1864/MAX1865

PIN		NAME	FUNCTION
MAX1864	MAX1865		
1	1	POK	Open-Drain Power-Good Output. POK is low when the output voltage is more than 10% below the regulation point. POK is high impedance when the output is in regulation. Connect a resistor between POK and VL for logic-level voltages.
2	2	COMP	Compensation Pin. Connect a series RC to GND to compensate the control loop. Typical values are 47kΩ and 8.2nF.
3	3	OUT	Regulated Output Voltage High-Impedance Sense Input. Internally connected to a resistive-divider and negative gain block (MAX1865).
4	4	FB	Dual Mode Switching-Regulator Feedback Input. Connect to GND for the preset 3.3V output. Connect to a resistive-divider from output to FB to GND to adjust the output voltage between 1.236V and $0.8 \times V_{IN}$. The feedback set point is 1.236V.
5	5	B2	Open-Drain Output PNP Transistor Driver (Regulator #2). Internally connected to the drain of a DMOS. B2 connects to the base of an external PNP pass transistor to form a positive linear regulator.
6	6	FB2	Analog Gain-Block Feedback Input (Regulator #2). Connect to a resistive-divider between the positive linear regulator's output and GND to adjust the output voltage. The feedback set point is 1.24V.
7	7	B3	Open-Drain Output PNP Transistor Driver (Regulator #3). Internally connected to the drain of a DMOS. B3 connects to the base of an external PNP pass transistor to form a positive linear regulator.
8	8	FB3	Analog Gain-Block Feedback Input (Regulator #3). Connect to a resistive-divider between the positive linear regulator's output and GND to adjust the output voltage. The feedback set point is 1.24V.
—	9	B4	Open-Drain Output PNP Transistor Driver (Regulator #4). Internally connected to the drain of a DMOS. B4 connects to the base of an external PNP pass transistor to form a positive linear regulator.
—	10	FB4	Analog Gain-Block Feedback Input (Regulator #4). Connect to a resistive-divider between the positive linear regulator's output and GND to adjust the output voltage. The feedback set point is 1.24V.
—	11	B5	Open-Drain Output NPN Transistor Driver (Regulator #5). Internally connected to the drain of a P-channel MOSFET. B5 connects to the base of an external NPN pass transistor to form a negative linear regulator.
—	12	FB5	Analog Gain-Block Feedback Input (Regulator #5). Connect to a resistive-divider between the negative linear regulator's output and a positive reference voltage, typically one of the positive linear regulator outputs, to adjust the output voltage. The feedback set point is at GND.

xDSL/Cable Modem Triple/Quintuple Output Power Supplies

Pin Description (continued)

PIN		NAME	FUNCTION
MAX1864	MAX1865		
9	13	ILIM	Dual Mode Current-Limit Adjustment Input. Connect to VL for the default 250mV current-limit threshold. In adjustable mode, the current-limit threshold voltage is 1/5th the voltage present at ILIM. Connect to a resistive-divider between VL and GND to adjust V_{ILIM} between 1V and 2.5V. The logic threshold for switchover to the 250mV default value is approximately $VL - 1V$.
10	14	GND	Ground
11	15	DL	Low-Side Gate-Driver Output. DL swings between GND and VL.
12	16	LX	Inductor Connection. Used for current sense between IN and LX, and used for current limit between LX and GND.
13	17	DH	High-Side Gate-Driver Output. DH swings between LX and BST.
14	18	BST	Boost Flying Capacitor Connection. Connect BST to the external boost diode and capacitor as shown in the standard application circuit (Figures 1 and 6).
15	19	VL	Internal 5V Linear-Regulator Output. Supplies the IC and powers the DL low-side gate driver and external boost diode and capacitor. Bypass with a 1 μ F or greater ceramic capacitor to GND.
16	20	IN	Input Supply Voltage, 4.5V to 28V. Bypass to GND with a 1 μ F or greater ceramic capacitor close to the IC.

Detailed Description

The MAX1864/MAX1865 power-supply controllers provide system power for cable and xDSL modems. The main step-down DC-DC controller operates in a current-mode pulse-width-modulation (PWM) control scheme to ease compensation requirements and provide excellent load- and line-transient response.

The MAX1864 includes two analog gain blocks to regulate two additional positive auxiliary output voltages, and the MAX1865 includes four analog gain blocks to regulate three additional positive and one negative auxiliary output voltages. The positive regulator gain blocks can be used to generate low-voltage rails directly from the main step-down converter or higher voltages using coupled windings from the step-down converter. The negative gain block can be used in conjunction with a coupled winding to generate -5V, -12V, or -15V.

DC-DC Controller

The MAX1864/MAX1865 step-down converters use a pulse-width-modulated (PWM) current-mode control scheme (Figure 2). An internal transconductance amplifier establishes an integrated error voltage at the COMP pin. The heart of the current-mode PWM controller is an open-loop comparator that compares the

integrated voltage-feedback signal against the amplified current-sense signal plus the slope compensation ramp. At each rising edge of the internal clock, the high-side MOSFET turns-on until the PWM comparator trips or the maximum duty cycle is reached. During this on-time, current ramps up through the inductor, sourcing current to the output and storing energy in a magnetic field. The current-mode feedback system regulates the peak inductor current as a function of the output voltage error signal. Since the average inductor current is nearly the same as the peak inductor current (assuming that the inductor value is relatively high to minimize ripple current), the circuit acts as a switch-mode transconductance amplifier. It pushes the output LC filter pole, normally found in a voltage-mode PWM, to a higher frequency. To preserve inner loop stability and eliminate inductor stair-casing, a slope-compensation ramp is summed into the main PWM comparator.

During the second-half of the cycle, the high-side MOSFET turns off and the low-side N-channel MOSFET turns on. Now the inductor releases the stored energy as its current ramps down, providing current to the output. Therefore, the output capacitor stores charge when the inductor current exceeds the load current and discharges when the inductor current is lower, smoothing

xDSL/Cable Modem Triple/Quintuple Output Power Supplies

MAX1864/MAX1865

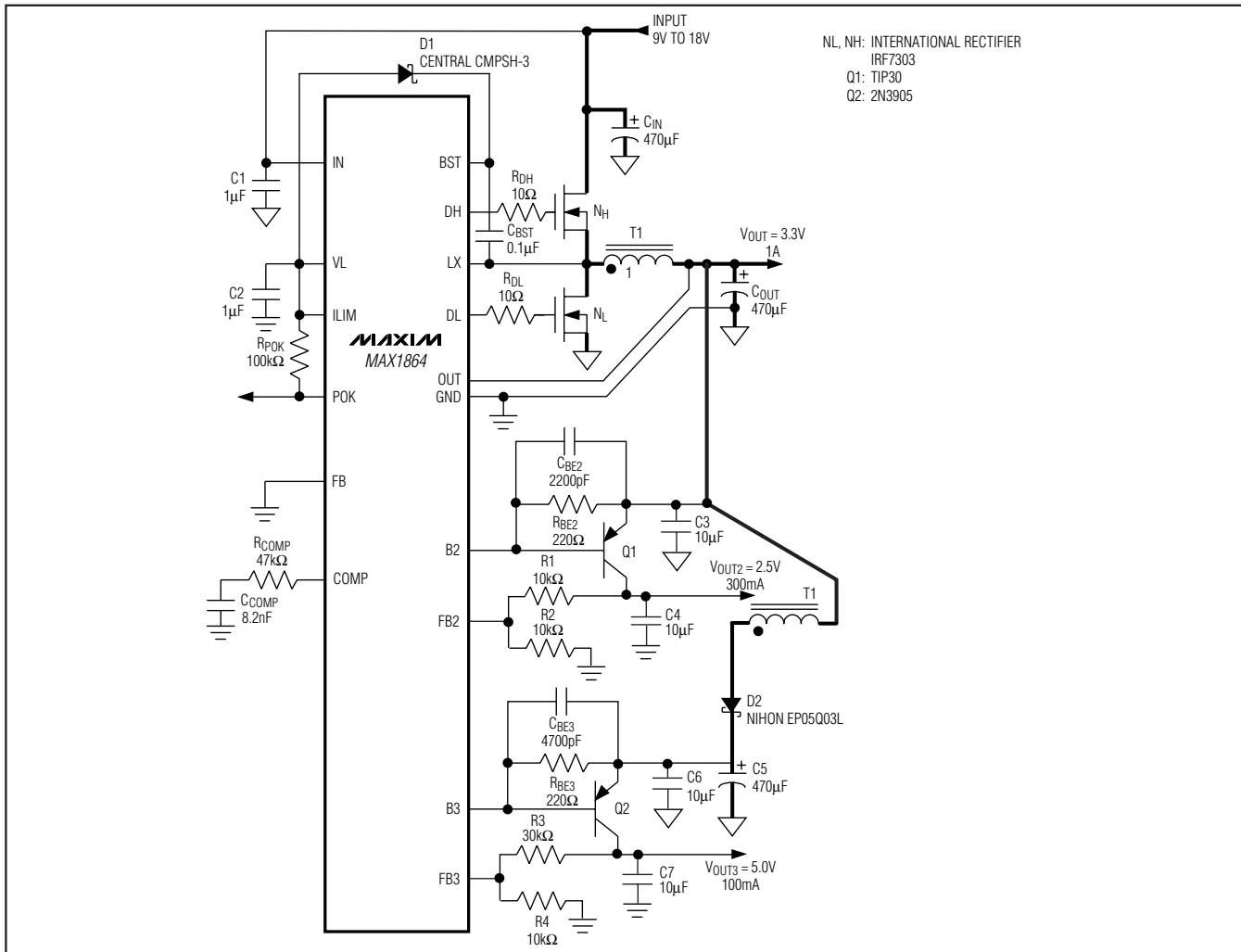

Figure 1. Standard MAX1864 Application Circuit

the voltage across the load. Under overload conditions, when the inductor current exceeds the selected current-limit (see the *Setting the Current Limit* section), the high-side MOSFET is not turned on at the rising edge of the clock and the low-side MOSFET remains on to let the inductor current ramp down.

The MAX1864/MAX1865 operate in a forced-PWM mode, so even under light loads the controller maintains a constant switching frequency to minimize cross-regulation errors in applications that use a transformer. The low-side gate-drive waveform is the complement of the high-side gate-drive waveform, which causes the inductor current to reverse under light loads.

Current-Sense Amplifier

The MAX1864/MAX1865s' current-sense circuit amplifies ($A_V = 5$) the current-sense voltage generated by the high-side MOSFET's on-resistance ($R_{DS(ON)} \times I_{INDUCTOR}$). This amplified current-sense signal and the internal slope compensation signal are summed together (V_{SUM}) and fed into the PWM comparator's inverting input. The PWM comparator turns-off the high-side MOSFET when V_{SUM} exceeds the integrated feedback voltage (V_{COMP}). Place the high-side MOSFET no further than 5mm from the controller, and connect IN and LX to the MOSFET using Kelvin sense connections to guarantee current-sense accuracy and improve stability.

xDSL/Cable Modem Triple/Quintuple Output Power Supplies

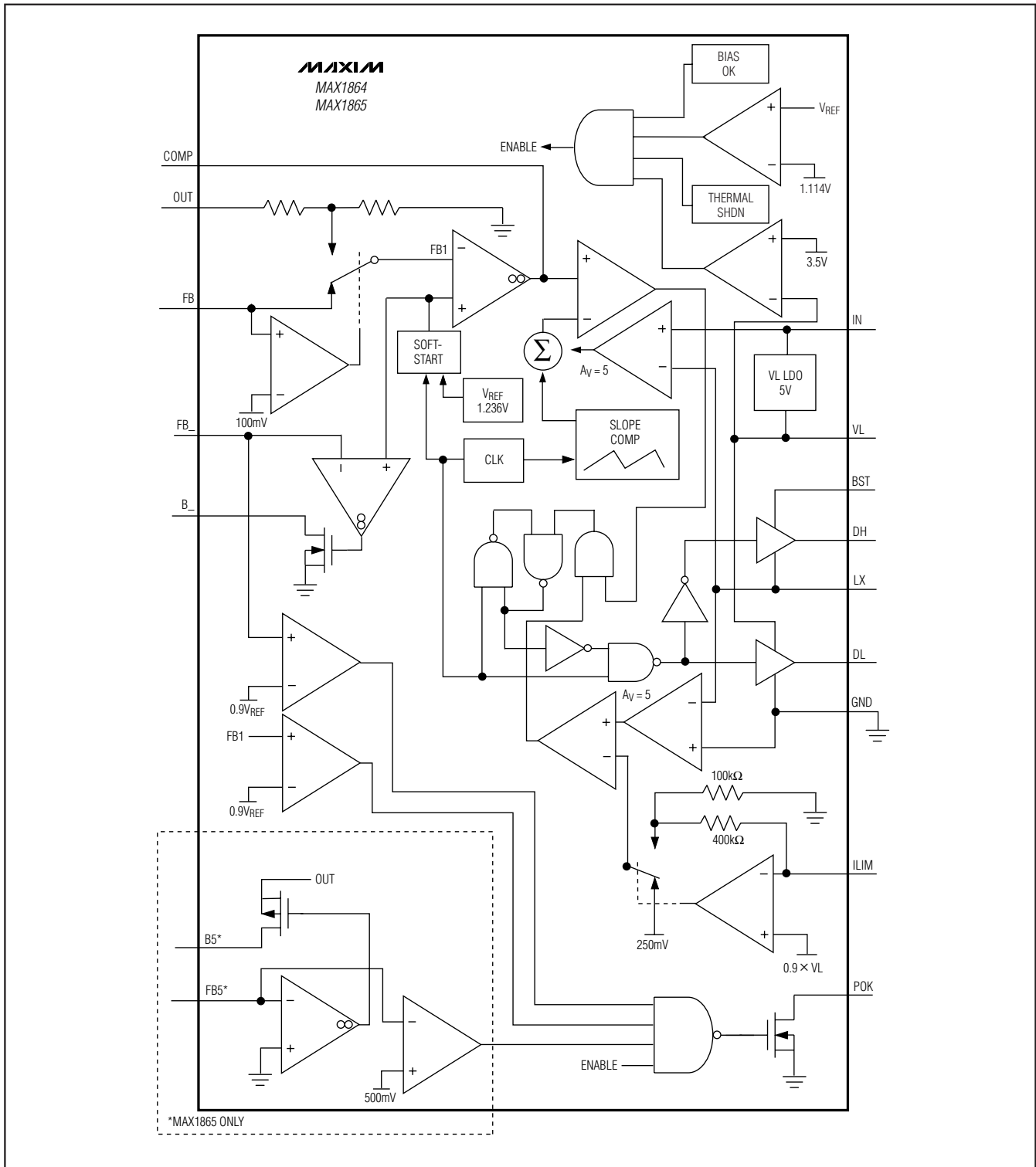

Figure 2. Functional Diagram

xDSL/Cable Modem Triple/Quintuple Output Power Supplies

MAX1864/MAX1865

Current-Limit Circuit

The current-limit circuit employs a unique “valley” current-limiting algorithm that uses the low-side MOSFET’s on-resistance as a sensing element (Figure 3). If the voltage across the low-side MOSFET ($R_{DS(ON)} \times I_{INDUCTOR}$) exceeds the current-limit threshold at the beginning of a new oscillator cycle, the MAX1864/MAX1865 will not turn on the high-side MOSFET. The actual peak current is greater than the current-limit threshold by an amount equal to the inductor ripple current. Therefore, the exact current-limit characteristic and maximum load capability are a function of the low-side MOSFET on-resistance, inductor value, input voltage, and output voltage. The reward for this uncertainty is robust, loss-less overcurrent limiting.

In adjustable mode, the current-limit threshold voltage is 1/5th the voltage seen at ILIM ($I_{VALLEY} = 0.2 \times V_{ILIM}$). Adjust the current-limit threshold by connecting a resistive-divider from VL to ILIM to GND. The current-limit threshold can be set from 106mV to 530mV, which corresponds to ILIM input voltages of 500mV to 2.5V. This adjustable current limit accommodates MOSFETs with a wide range of on-resistance characteristics (see *Design Procedure*). The current-limit threshold defaults to 250mV when ILIM is connected to VL. The logic threshold for switchover to the 250mV default value is approximately VL - 1V.

Carefully observe the PC board layout guidelines to ensure that noise and DC errors don’t corrupt the current-sense signals seen by LX and GND. The IC must be mounted close to the low-side MOSFET with short (less than 5mm), direct traces making a Kelvin sense connection.

Synchronous Rectifier Driver (DL)

Synchronous rectification reduces conduction losses in the rectifier by replacing the normal Schottky catch diode with a low-resistance MOSFET switch. The MAX1864/MAX1865 also use the synchronous rectifier to ensure proper startup of the boost gate-driver circuit and to provide the current-limit signal.

The DL low-side drive waveform is always the complement of the DH high-side drive waveform (with controlled dead time to prevent cross-conduction or “shoot-through”). A dead-time circuit monitors the DL output and prevents the high-side FET from turning on until DL is fully off. For the dead-time circuit to work properly, there must be a low-resistance, low-inductance path from the DL driver to the MOSFET gate. Otherwise, the sense circuitry in the MAX1864/MAX1865 will interpret the MOSFET gate as “off” when gate charge actually remains. Use very short, wide

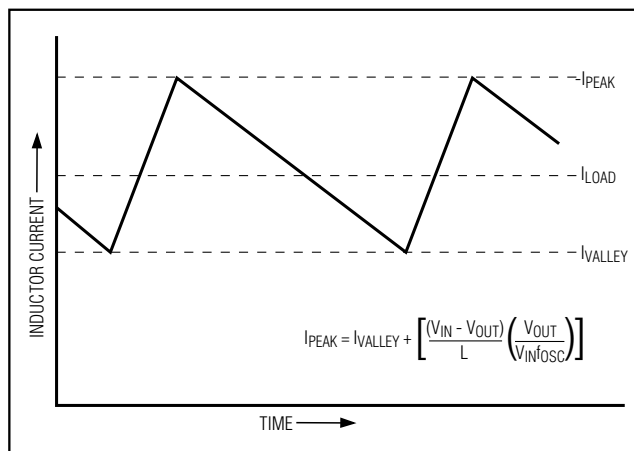

Figure 3. “Valley” Current-Limit Threshold Point

traces (50mil to 100mil wide if the MOSFET is 1 inch from the device). The dead time at the other edge (DH turning off) is determined by a fixed internal delay.

High-Side Gate-Drive Supply (BST)

Gate-drive voltage for the high-side N-channel switch is generated by a flying-capacitor boost circuit (Figure 1). The capacitor between BST and LX is alternately charged from the VL supply and placed parallel to the high-side MOSFET’s gate-source terminals.

On startup, the synchronous rectifier (low-side MOSFET) forces LX to ground and charges the boost capacitor to 5V. On the second half-cycle, the switch-mode power supply turns on the high-side MOSFET by closing an internal switch between BST and DH. This provides the necessary gate-to-source voltage to turn on the high-side switch, an action that boosts the 5V gate-drive signal above the battery voltage.

Internal 5V Linear Regulator (VL)

All MAX1864/MAX1865 functions, except the current-sense amplifier, are internally powered from the on-chip, low-dropout 5V regulator. The maximum regulator input voltage (V_{IN}) is 28V. Bypass the regulator’s output (VL) with at least a 1 μ F ceramic capacitor to GND. The V_{IN} -to-VL dropout voltage is typically 200mV, so when V_{IN} is less than 5.2V, VL is typically $V_{IN} - 200mV$.

The internal linear regulator can source up to 20mA to supply the IC, power the low-side gate driver, charge the external boost capacitor, and supply small external loads. When driving particularly large FETs, little or no regulator current may be available for external loads. For example, when switched at 200kHz, a large FET with 40nC total gate charge requires 40nC x 200kHz, or 8mA.

xDSL/Cable Modem Triple/Quintuple Output Power Supplies

Undervoltage Lockout

If VL drops below 3.5V, the MAX1864/MAX1865 assume that the supply voltage is too low to make valid decisions, so the undervoltage lockout (UVLO) circuitry inhibits switching, forces POK low, and forces the DL and DH gate drivers low. After VL rises above 3.5V, internal digital soft-start is initiated (see *Soft-Start*).

Startup Sequence

Externally, the MAX1864/MAX1865 starts switching when VL rises above the 3.5V undervoltage lockout threshold. However, the controller is not enabled unless all four of the following conditions are met: 1) VL exceeds the 3.5V undervoltage lockout threshold, 2) the internal reference exceeds 90% of its nominal value ($V_{REF} > 1.114V$), 3) the internal bias circuitry powers up, and 4) the thermal limit is not exceeded. Once the MAX1864/MAX1865 assert the internal enable signal, the step-down controller starts switching and enables soft-start.

Soft-Start

Upon power-up, the MAX1864/MAX1865 begin a start-up sequence. First, the reference powers up. Then, the main DC-DC step-down converter and positive linear regulators power up with soft-start enabled. Once the regulators reach 90% of their nominal value and soft-start is complete, the active-high ready signal (POK) goes high (see *Power-Good Output*).

Soft-start gradually ramps up to the reference voltage in order to control the rate of rise of the output voltages and reduce input surge currents during startup. The soft-start period is 1024 clock cycles ($1024/f_{OSC}$), and the internal soft-start DAC ramps up the voltage in 64 steps. The output reaches regulation when soft-start is completed, regardless of output capacitance and load.

Power-Good Output

The power-good output (POK) is an open-drain output. The MOSFET turns on and pulls POK low when any output is less than 90% of its nominal regulation voltage or during soft-start. Once all of the outputs exceed 90% of their nominal regulation voltages and soft-start is completed, POK goes high impedance. To obtain a logic voltage output, connect a pullup resistor from POK to VL. A 100k Ω resistor works well for most applications. If unused, leave POK grounded or unconnected.

Thermal-Overload Protection

Thermal-overload protection limits total power dissipation in the MAX1864/MAX1865. When the junction temperature exceeds $T_J = +160^\circ C$, a thermal sensor shuts down the device, forcing DL and DH low, allowing the IC to cool. The thermal sensor turns the part on again after the junction temperature cools by $10^\circ C$, resulting in a pulsed output during continuous thermal-overload conditions. If the VL output is short circuited, thermal-overload protection is disabled.

During a thermal event, the main step-down converter and the linear regulators are turned off, POK goes low, and soft-start is reset.

Design Procedure

DC-DC Step-Down Converter

Output Voltage Selection

The step-down controller's feedback input features Dual Mode operation. Connect the output to OUT and connect FB to GND for the preset 3.3V output voltage. Alternatively, the MAX1864/MAX1865 output voltage may be adjusted by connecting a voltage-divider from the output to FB to GND (Figure 4). Select R2 in the 5k Ω to 50k Ω range. Calculate R1 with the following equation:

$$R1 = R2 \left[\left(\frac{V_{OUT}}{V_{SET}} \right) - 1 \right]$$

where $V_{SET} = 1.236V$, and V_{OUT} may range from 1.236V to approximately $0.8 \times V_{IN}$ (up to 20V). If $V_{OUT} > 5.5V$, then connect OUT to GND (MAX1864) or to one of the positive linear regulators (MAX1865) with an output voltage between 2V and 5V.

Inductor Value

Three key inductor parameters must be specified: inductance value (L), peak current (I_{PEAK}), and DC resistance (R_{DC}). The following equation includes a constant LIR, which is the ratio of inductor peak-to-peak AC current to DC load current. A higher LIR value allows smaller inductance but results in higher losses and higher output ripple. A good compromise between size and losses is a 30% ripple-current to load-current ratio ($LIR = 0.3$). The switching frequency, input voltage, output voltage, selected LIR determine the inductor value as follows:

$$L = \frac{V_{OUT}(V_{IN} - V_{OUT})}{V_{IN} f_{SW} I_{LOAD} (MAX) LIR}$$

xDSL/Cable Modem Triple/Quintuple Output Power Supplies

MAX1864/MAX1865

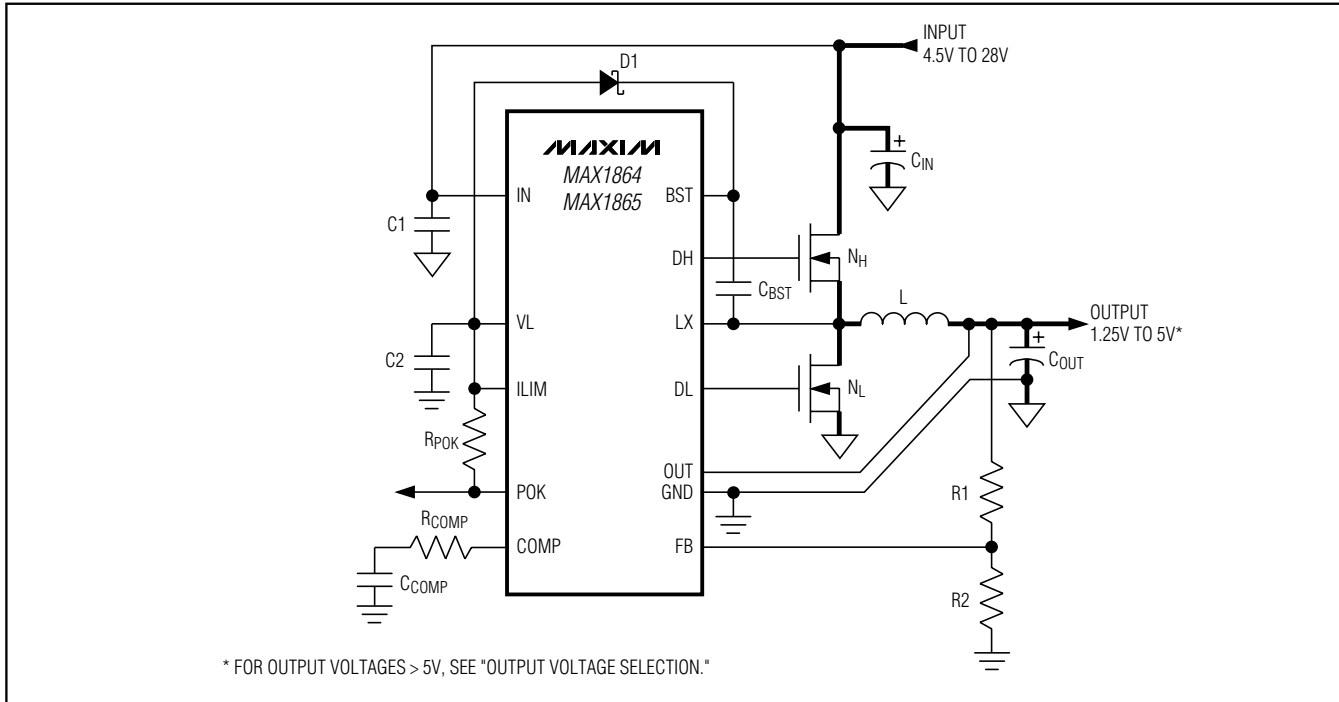

Figure 4. Adjustable Output Voltage

where f_{sw} is 200kHz for MAX186_T and 100kHz for MAX186_U. The exact inductor value is not critical and can be adjusted to make trade-offs among size, cost, and efficiency. Lower inductor values minimize size and cost, but they also increase the output ripple and reduce the efficiency due to higher peak currents. On the other hand, higher inductor values increase efficiency, but at some point resistive losses due to extra turns of wire will exceed the benefit gained from lower AC current levels.

Find a low-loss inductor having the lowest possible DC resistance that fits in the allotted dimensions. Ferrite cores are often the best choice, though powdered iron is inexpensive and can work well at 200kHz. The chosen inductor's saturation rating must exceed the peak inductor current:

$$I_{PEAK} = I_{LOAD(MAX)} + \left(\frac{LIR}{2}\right) I_{LOAD(MAX)}$$

Setting the Current Limit

The minimum current-limit threshold must be high enough to support the maximum load current at the minimum tolerance level of the current-limit circuit. The

valley of the inductor current occurs at $I_{LOAD(MAX)}$ minus half of the ripple current:

$$\frac{V_{VALLEY(LOW)}}{R_{DS(ON)}} > I_{LOAD(MAX)} - \left(\frac{LIR}{2}\right) I_{LOAD(MAX)}$$

where $R_{DS(ON)}$ is the on-resistance of the low-side MOSFET (N_L). For the MAX1864/MAX1865, the minimum current-limit threshold is 190mV (for the typical 250mV default setting). Use the worst-case maximum value for $R_{DS(ON)}$ from the MOSFET N_L data sheet, and add some margin for the rise in $R_{DS(ON)}$ over temperature. A good general rule is to allow 0.5% additional resistance for each °C of the MOSFET junction temperature rise.

Connect ILIM to VL for the default 250mV (typ) current-limit threshold. For an adjustable threshold, connect a resistive-divider from VL to ILIM to GND. The 500mV to 2.5V external adjustment range corresponds to a 106mV to 530mV current-limit threshold. When adjusting the current limit, use 1% tolerance resistors and a 10µA divider current to prevent a significant increase in the current-limit tolerance.

xDSL/Cable Modem Triple/Quintuple Output Power Supplies

MOSFET Selection

The MAX1864/MAX1865s' step-down controller drives two external logic-level N-channel MOSFETs as the circuit switch elements. The key selection parameters are:

- On-resistance ($R_{DS(ON)}$)
- Maximum drain-to-source voltage ($V_{DS(MAX)}$)
- Minimum threshold voltage ($V_{TH(MIN)}$)
- Total gate charge (Q_g)
- Reverse transfer capacitance (C_{RSS})

The high-side N-channel MOSFET must be a logic-level type with guaranteed on-resistance specifications at $V_{GS} \leq 4.5V$. Select the high-side MOSFET's $R_{DS(ON)}$ so $I_{PEAK} \times R_{DS(ON)} \leq 225mV$ for the current-sense range. For maximum efficiency, choose a high-side MOSFET (N_H) that has conduction losses equal to the switching losses at the optimum input voltage. Check to ensure that the conduction losses at minimum input voltage don't exceed the package thermal limits or violate the overall thermal budget. Check to ensure that the conduction losses plus switching losses at the maximum input voltage don't exceed package ratings or violate the overall thermal budget.

The low-side MOSFET (N_L) provides the current-limit signal, so choose a MOSFET with an $R_{DS(ON)}$ large enough to provide adequate circuit protection (see *Setting the Current Limit*):

$$R_{DS(ON)} = \frac{V_{VALLEY}}{I_{VALLEY}}$$

Use the worst-case maximum value for $R_{DS(ON)}$ from the MOSFET N_L data sheet, and add some margin for the rise in $R_{DS(ON)}$ over temperature. A good general rule is to allow 0.5% additional resistance for each °C of the MOSFET junction temperature rise. Ensure that the MAX1864/MAX1865 DL gate drivers can drive N_L ; in other words, check that the dv/dt caused by N_H turning on does not pull up the N_L gate due to drain-to-gate capacitance, causing cross-conduction problems.

MOSFET package power dissipation often becomes a dominant design factor. I^2R power losses are the greatest heat contributor for both high-side and low-side MOSFETs. I^2R losses are distributed between N_H and N_L according to duty factor as shown in the equations below. Generally, switching losses affect only the high-side MOSFET since the low-side MOSFET is a zero-voltage switched device when used in the buck topology.

Gate-charge losses are dissipated by the driver and do not heat the MOSFET. Calculate the temperature rise according to package thermal-resistance specifications

to ensure that both MOSFETs are within their maximum junction temperature at high ambient temperature. The worst-case dissipation for the high-side MOSFET (P_{NH}) occurs at both extremes of input voltage, and the worst-case dissipation for the low-side MOSFET (P_{NL}) occurs at maximum input voltage.

$$\text{Duty Cycle: } D = \frac{V_{OUT}}{V_{IN}}$$

$$P_{NH(SWITCHING)} = V_{IN} I_{LOAD} f_{OSC} \left(\frac{V_{IN} C_{RSS}}{I_{GATE}} \right)$$

$$P_{NH(CONDUCTION)} = I_{LOAD}^2 R_{DS(ON)NH} D$$

$$P_{NH(TOTAL)} = P_{NH(SWITCHING)} +$$

$$P_{NH(CONDUCTION)}$$

$$P_{NL} = I_{LOAD}^2 R_{DS(ON)NL} (1 - D)$$

where I_{GATE} is the DH driver peak output current capability (1A typ), and 20ns is the DH driver inherent rise/fall-time. To reduce EMI caused by switching noise, add a 0.1 μ F ceramic capacitor from the high-side switch drain to the low-side switch source, or add resistors (47 Ω max) in series with DL and DH to increase the switches' turn-on and turn-off times (Figure 5).

The minimum load current should exceed the high-side MOSFET's maximum leakage current over temperature if fault conditions are expected.

Input Capacitor

The input filter capacitor reduces peak currents drawn from the power source and reduces noise and voltage ripple on the input caused by the circuit's switching. The input capacitor must meet the ripple current requirement (I_{RMS}) imposed by the switching currents defined by the following equation:

$$I_{RMS} = I_{LOAD} \frac{\sqrt{V_{OUT}(V_{IN} - V_{OUT})}}{V_{IN}}$$

For most applications, nontantalum capacitors (ceramic, aluminum, polymer, or OS-CON) are preferred due to their robustness with high inrush currents typical of systems with low-impedance battery inputs. Additionally, two (or more) smaller value low-ESR capacitors can be connected in parallel for lower cost. Choose an input capacitor that exhibits less than +10°C temperature rise at the RMS input current for optimal circuit long-term reliability.

xDSL/Cable Modem Triple/Quintuple Output Power Supplies

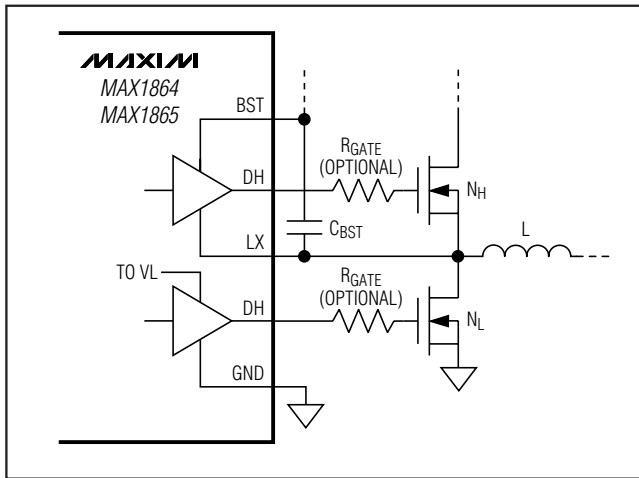

Figure 5. Reducing the Switching EMI

Output Capacitor

The key selection parameters for the output capacitor are the actual capacitance value, the equivalent series resistance (ESR), and voltage-rating requirements, which affect the overall stability, output ripple voltage, and transient response.

The output ripple has two components: variations in the charge stored in the output capacitor, and the voltage drop across the capacitor's ESR caused by the current into and out of the capacitor:

$$V_{\text{RIPPLE}} = V_{\text{RIPPLE(ESR)}} + V_{\text{RIPPLE(C)}}$$

The output voltage ripple as a consequence of the ESR and output capacitance is:

$$V_{\text{RIPPLE(ESR)}} = I_{\text{P-P}} \text{ESR}$$

$$V_{\text{RIPPLE(C)}} = \frac{I_{\text{P-P}}}{2C_{\text{OUT}} f_{\text{SW}}}$$

$$I_{\text{P-P}} = \left(\frac{V_{\text{IN}} - V_{\text{OUT}}}{f_{\text{SW}} L} \right) \left(\frac{V_{\text{OUT}}}{V_{\text{IN}}} \right)$$

where $I_{\text{P-P}}$ is the peak-to-peak inductor current (see *Inductor Value* section). These equations are suitable for initial capacitor selection, but final values should be set by testing a prototype or evaluation circuit. As a general rule, a smaller ripple current results in less output ripple. Since the inductor ripple current is a factor of the inductor value and input voltage, the output voltage ripple decreases with larger inductance but increases with lower input voltages.

With low-cost aluminum electrolytic capacitors, the ESR-induced ripple can be larger than that caused by the current into and out of the capacitor. Consequently, high-quality low-ESR aluminum-electrolytic, tantalum, polymer, or ceramic filter capacitors are required to minimize output ripple. Best results at reasonable cost are typically achieved with an aluminum-electrolytic capacitor in the 470 μ F range, in parallel with a 0.1 μ F ceramic capacitor.

Since the MAX1864/MAX1865 use a current-mode control scheme, the output capacitor forms a pole that affects circuit stability (see *Compensation Design*). Furthermore, the output capacitor's ESR also forms a zero.

The MAX1864/MAX1865s' response to a load transient depends on the selected output capacitor. After a load transient, the output instantly changes by $\text{ESR} \times \Delta I_{\text{LOAD}}$. Before the controller can respond, the output will sag further, depending on the inductor and output capacitor values.

After a short period of time (see *Typical Operating Characteristics*), the controller responds by regulating the output voltage back to its nominal state. For applications that have strict transient requirements, low-ESR high-capacitance electrolytic capacitors are recommended to minimize the transient voltage swing.

Do not exceed the capacitor's voltage or ripple-current ratings.

Compensation Design

The MAX1864/MAX1865 controllers use an internal transconductance error amplifier whose output compensates the control loop. Connect a series resistor and capacitor between COMP and GND to form a pole-zero pair. The external inductor, high-side MOSFET, output capacitor, compensation resistor, and compensation capacitor determine the loop stability. The inductor and output capacitor are chosen based on performance, size, and cost. Additionally, the compensation resistor and capacitor are selected to optimize control-loop stability. The component values shown in the standard application circuits (Figures 1 and 6) yield stable operation over a broad range of input-to-output voltages.

The controller uses a current-mode control scheme that regulates the output voltage by forcing the required current through the external inductor, so the MAX1864/MAX1865 use the voltage across the high-side MOSFET's $R_{\text{DS(ON)}}$ to sense the inductor current. Using the current-sense amplifier's output signal and the amplified feedback voltage, the control loop determines the peak inductor current by:

xDSL/Cable Modem Triple/Quintuple Output Power Supplies

$$I_{PEAK} = \frac{V_{OUT} V_{REF} A_{VEA}}{V_{OUT(NOMINAL)} R_{DS(ON)} A_{VCS}}$$

where A_{VCS} is the current-sense amplifier's gain (4.9 typ), A_{VEA} is the DC gain of the error amplifier (2000 typ), and $V_{OUT(NOMINAL)}$ is the output voltage set by the feedback resistive-divider (internal or external). Since the output voltage is a function of the load current and load resistance, the total DC loop gain ($A_{V(DC)}$) is approximately:

$$\begin{aligned} A_{V(DC)} &\approx \frac{I_{PEAK}}{I_{LOAD}} \approx \frac{V_{REF} R_{LOAD} A_{VEA}}{V_{OUT(NOMINAL)} R_{DS(ON)} A_{VCS}} \\ &\approx \frac{400 \times V_{REF} R_{LOAD}}{V_{OUT(NOMINAL)} R_{DS(ON)}} \end{aligned}$$

The compensation capacitor (C_{COMP}) creates the dominant pole. Due to the current-mode control scheme, the output capacitor also creates a pole in the system that is a function of the load resistance. As the load resistance increases, the frequency of the output capacitor's pole decreases. However, the DC loop gain increases with larger load resistance, so the unity gain bandwidth remains fixed. Additionally, the compensation resistor and the output capacitor's ESR both generate zeros. Therefore, to achieve stable operation, use the following procedure to properly compensate the system:

- 1) First, select the desired crossover frequency. The crossover frequency must be less than both 1/5th the switching frequency and 1/3rd the zero frequency set by the output capacitor's ESR:

$$f_c \leq \frac{1}{6\pi C_{OUT} R_{ESR}} \quad \text{and} \quad \frac{f_{SW}}{5}$$

- 2) Next, determine the pole set by the output capacitor and the load resistor:

$$f_{POLE(OUT)} = \frac{1}{2\pi C_{OUT} R_{LOAD}} = \frac{I_{LOAD(MAX)}}{2\pi C_{OUT} V_{OUT}}$$

- 3) Determine the compensation resistor required to set the desired crossover frequency:

$$R_{COMP} = \frac{2000 \times f_c}{g_m A_{V(DC)} f_{POLE(OUT)}}$$

where the error amplifier's transconductance (g_m) is $100\mu S$ (see *Electrical Characteristics*).

- 4) Finally, select the compensation capacitor:

$$C_{COMP} \leq \frac{1}{2\pi R_{COMP} f_{POLE(OUT)}}$$

Boost-Supply Diode

A signal diode, such as the 1N4148, works well in most applications. If the input voltage goes below 6V, use a small 20mA Schottky diode for slightly improved efficiency and dropout characteristics. Do not use large power diodes, such as the 1N5817 or 1N4001, since high junction capacitance can charge up V_L to excessive voltages.

Linear Regulator Controllers

Positive Output Voltage Selection

The MAX1864/MAX1865's positive linear regulator output voltages are set by connecting a voltage-divider from the output to FB_- to GND (Figure 6). Select R_4 in the $5k\Omega$ to $50k\Omega$ range. Calculate R_3 with the following equation:

$$R_3 = R_4 \left[\left(\frac{V_{OUT}}{V_{FB}} \right) - 1 \right]$$

where $V_{FB} = 1.24V$, and V_{OUT} may range from 1.24V to 30V.

Negative Output Voltage Selection (MAX1865)

The MAX1865's negative output voltage is set by connecting a voltage-divider from the output to FB_5 to a positive voltage reference (Figure 6). Select R_6 in the $5k\Omega$ to $50k\Omega$ range. Calculate R_5 with the following equation:

$$R_5 = R_6 \left(\frac{V_{OUT}}{V_{REF}} \right)$$

where V_{REF} is the positive reference voltage used, and V_{OUT} may be set between 0 and -20V.

If the negative regulator is used, the OUT pin must be connected to a voltage supply between 2V and 5V that can source at least 25mA. Typically, the OUT pin is connected to the step-down converter's output. However, if the step-down converter's output voltage is set higher than 5V, OUT may be connected to one of the positive linear regulators with an output voltage between 2V and 5V.

xDSL/Cable Modem Triple/Quintuple Output Power Supplies

MAX1864/MAX1865

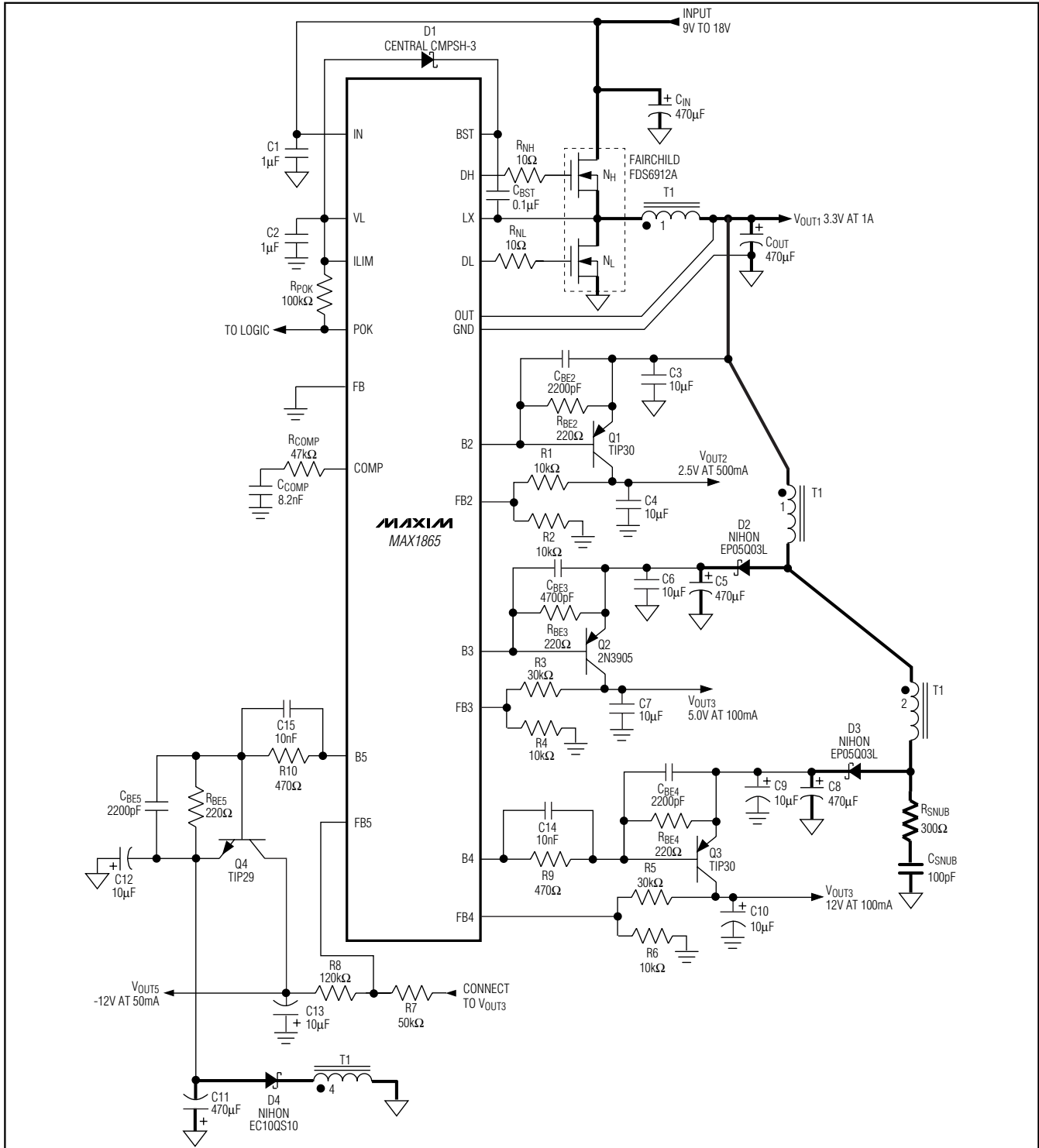

Figure 6. Standard MAX1865 Application Circuit

xDSL/Cable Modem Triple/Quintuple Output Power Supplies

Transistor Selection

The pass transistors must meet specifications for current gain (h_{FE}), input capacitance, collector-emitter saturation voltage, and power dissipation. The transistor's current gain limits the guaranteed maximum output current to:

$$I_{LOAD(MAX)} = \left[I_{DRV} - \left(\frac{V_{BE}}{R_{BE}} \right) \right] h_{FE(MIN)}$$

where I_{DRV} is the minimum base-drive current, and R_{BE} (220Ω) is the pullup resistor connected between the transistor's base and emitter. Furthermore, the transistor's current gain increases the linear regulator's DC loop gain (see *Stability Requirements*), so excessive gain will destabilize the output. Therefore, transistors with current gain over 100 at the maximum output current, such as Darlington transistors, are not recommended. The transistor's input capacitance and input resistance also create a second pole, which could be low enough to destabilize the output when heavily loaded.

The transistor's saturation voltage at the maximum output current determines the minimum input-to-output voltage differential that the linear regulator will support. Alternatively, the package's power dissipation could limit the useable maximum input-to-output voltage differential. The maximum power dissipation capability of the transistor's package and mounting must exceed the actual power dissipation in the device. The power dissipated equals the maximum load current times the maximum input-to-output voltage differential:

$$P = I_{LOAD(MAX)}(V_{LDOIN} - V_{OUT}) = I_{LOAD(MAX)}V_{CE}$$

Stability Requirements

The MAX1864/MAX1865 linear regulators use an internal transconductance amplifier to drive an external pass transistor. The transconductance amplifier, pass transistor's specifications, the base-emitter resistor, and the output capacitor determine the loop stability. If the output capacitor and pass transistor are not properly selected, the linear regulator will be unstable.

The transconductance amplifier regulates the output voltage by controlling the pass transistor's base current. Since the output voltage is a function of the load current and load resistance, the total DC loop gain ($A_{V(LDO)}$) is approximately:

$$A_{V(LDO)} \approx \left(\frac{5.5}{V_T} \right) \left[1 + \left(\frac{I_{BIAS} h_{FE}}{I_{LOAD}} \right) \right] V_{REF}$$

where V_T is 26mV, and I_{BIAS} is the current through the base-to-emitter resistor (R_{BE}). This bias resistor is typically 220Ω , providing approximately 3.2mA of bias current.

The output capacitor creates the dominant pole. However, the pass transistor's input capacitance creates a second pole in the system. Additionally, the output capacitor's ESR generates a zero, which may be used to cancel the second pole if necessary. Therefore, to achieve stable operation, use the following equations to verify that the linear regulator is properly compensated:

- 1) First, determine the dominant pole set by the linear regulator's output capacitor and the load resistor:

$$f_{POLE(CLDO)} = \frac{1}{2\pi C_{LDO} R_{LOAD}} = \frac{I_{LOAD(MAX)}}{2\pi C_{LDO} V_{LDO}}$$

$$\text{Unity Gain Crossover} = A_{V(LDO)} f_{POLE(CLDO)}$$

- 2) Next, determine the second pole set by the base-to-emitter capacitance (including the transistor's input capacitance), the transistor's input resistance, and the base-to-emitter pullup resistor:

$$\begin{aligned} f_{POLE(CBE)} &= \frac{1}{2\pi C_{BE} (R_{BE} \parallel R_{IN(NPN)})} \\ &= \frac{R_{BE} I_{LOAD} + V_T h_{FE}}{2\pi C_{BE} R_{BE} V_T h_{FE}} \end{aligned}$$

- 3) A third pole is set by the linear regulator's feedback resistance and the capacitance between FB_- and GND, including 20pF stray capacitance:

$$f_{POLE(FB)} = \frac{1}{2\pi C_{FB} (R1 \parallel R2)}$$

- 4) If the second and third poles occur well after unity-gain crossover, the linear regulator will remain stable:

$$f_{POLE(CBE)} > 2f_{POLE(CLDO)} A_{V(LDO)}$$

However, if the ESR zero occurs before unity-gain crossover, cancel the zero with $f_{POLE(FB)}$ by changing circuit components such that:

xDSL/Cable Modem Triple/Quintuple Output Power Supplies

MAX1864/MAX1865

$$f_{\text{POLE(FB)}} \approx \frac{1}{2\pi C_{\text{OUT}} R_{\text{ESR}}}$$

Do not use output capacitors with more than 200mΩ of ESR. Typically, more output capacitance provides the best solution, since this also reduces the output voltage drop immediately after a load transient.

Linear Regulator Output Capacitors

Connect at least a 1μF capacitor between the linear regulator's output and ground, as close to the MAX1864/MAX1865 and external pass transistors as possible. Depending on the selected pass transistor, larger capacitor values may be required for stability (see *Stability Requirements*). Furthermore, the output capacitor's ESR affects stability, providing a zero that may be necessary to cancel the second pole. Use output capacitors with an ESR less than 200mΩ to ensure stability and optimum transient response.

Once the minimum capacitor value for stability is determined, verify that the linear regulator's output does not contain excessive noise. Although adequate for stability, small capacitor values may provide too much bandwidth, making the linear regulator sensitive to noise. Larger capacitor values reduce the bandwidth, thereby reducing the regulator's noise sensitivity.

If noise on the ground reference causes the design to be marginally stable for the negative linear regulator, bypass the negative output back to its reference voltage (V_{REF}, Figure 7). This technique reduces the differential noise on the output.

Base-Drive Noise Reduction

The high-impedance base driver is susceptible to system noise, especially when the linear regulator is lightly loaded. Capacitively coupled switching noise or inductively coupled EMI onto the base drive causes fluctuations in the base current, which appear as noise on the linear regulator's output. Keep the base-drive traces away from the step-down converter and as short as possible to minimize noise coupling. Resistors in series with the gate drivers (DH and DL) reduce the LX switching noise generated by the step-down converter (Figure 5). Additionally, a bypass capacitor may be placed across the base-to-emitter resistor (Figure 7). This bypass capacitor, in addition to the transistor's input capacitance, could bring in a second pole that will destabilize the linear regulator (see *Stability Requirements*). Therefore, the stability requirements determine the maximum base-to-emitter capacitance:

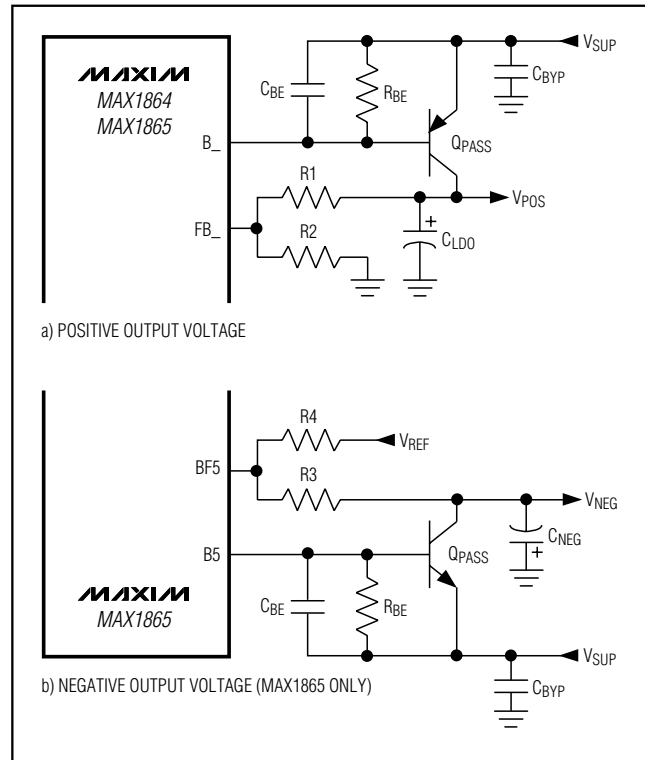

Figure 7. Base-Drive Noise Reduction

$$C_{\text{BE}} \leq \frac{1}{2\pi f_{\text{POLE(CBE)}}} \left(\frac{R_{\text{BE}} I_{\text{LOAD}} + V_{\text{T}} h_{\text{FE}}}{R_{\text{BE}} V_{\text{T}} h_{\text{FE}}} \right) - C_{\text{IN(Q)}}$$

where C_{IN(Q)} is the transistor's input capacitance, and f_{POLE(CBE)} is the second pole required for stability.

Transformer Selection

In systems where the step-down controller's output is not the highest voltage, a transformer may be used to provide additional postregulated, high-voltage outputs. The transformer generates unregulated, high-voltage supplies that power the positive and negative linear regulators. These unregulated supply voltages must be high enough to keep the pass transistors from saturating. For positive output voltages, connect the transformer as shown in figure 6 where the minimum turns ratio (N) is determined by:

$$N_{\text{POS}} \geq \left(\frac{V_{\text{LDQ(POS)}} + V_{\text{SAT}} + V_{\text{DIODE}}}{V_{\text{OUT}}} - 1 \right)$$

where V_{SAT} is the pass transistor's saturation voltage under full load. For negative output voltages (MAX1865

xDSL/Cable Modem Triple/Quintuple Output Power Supplies

only), connect the transformer as shown in Figure 6, where the minimum turns ratio is determined by:

$$N_{\text{NEG}} \geq \left(\frac{|V_{\text{LDO(NEG)}}| + V_{\text{SAT}} + V_{\text{DIODE}}}{V_{\text{OUT}}} \right)$$

Since power transfer occurs when the low-side MOSFET is on (DL = high), the transformer cannot support heavy loads with high duty cycles.

Snubber Design

The MAX1864/MAX1865 use a current-mode control scheme that senses the current across the high-side MOSFET (NH). Immediately after the high-side MOSFET has turned on, the MAX1864/MAX1865 use a 60ns current-sense blanking period to minimize noise sensitivity. When the MOSFET turns on, however, the transformer's secondary inductance and the diode's parasitic capacitance form a resonant circuit that causes ringing. Reflected back through the transformer to the primary side, these oscillations across the high-side MOSFET may last longer than the blanking period. A series RC snubber circuit at the diode (Figure 6) increases the damping factor, allowing the ringing to settle quickly. Applications with multiple transformer windings require only one snubber circuit on the highest output voltage. Applications with low turn ratios (1:1), such as the MAX1864 typical application circuit (Figure 1), may not require a snubber circuit.

The diode's parasitic capacitance can be estimated using the diode's reverse voltage rating (V_{RRM}), current capability (I_{O}), and recovery time (T_{RR}). A rough approximation is:

$$C_{\text{DIODE}} = \frac{I_{\text{O}} \times t_{\text{RR}}}{V_{\text{RRM}}}$$

For the EC10QS10 Nihon diode used in figure 6, the capacitance is roughly 15pF. The output snubber must only dampen the ringing, so the initial turn-on spike that occurs during the blanking period remains preset. A 100pF capacitor works well in most applications; larger capacitance values require more charge, thereby increasing the power dissipation.

The snubber's time constant (t_{SNUB}) must be smaller than the 100ns blanking time. A typical RC time constant of approximately 30ns was chosen for Figure 6:

$$R_{\text{SNUB}} = \frac{t_{\text{SNUB}}}{C_{\text{SNUB}}} = \frac{30\text{ns}}{C_{\text{SNUB}}}$$

Minimum Load Requirements (Linear Regulators)

Under no-load conditions, leakage currents from the pass transistors supply the output capacitor, even when the transistor is off. Generally, this is not a problem since the feedback resistors' current drains the excess charge. However, charge may build up on the output capacitor over temperature, making V_{LDO} rise above its set point. Care must be taken to ensure that the feedback resistors' current exceeds the pass transistor's leakage current over the entire temperature range.

Applications Information

PC Board Layout Guidelines

Careful PC board layout is critical to achieve low switching losses and clean, stable operation. The switching power stage requires particular attention. Follow these guidelines for good PC board layout:

- 1) Place the power components first, with ground terminals adjacent (N_{L} source, C_{IN} , C_{OUT}). If possible, make all these connections on the top layer with wide, copper-filled areas. Keep these high-current paths short, especially at ground terminals.
- 2) Mount the MAX1864/MAX1865 adjacent to the switching MOSFETs to keep IN-LX current-sense lines, LX-GND current-limit sense lines, and the driver lines (DL and DH) short and wide. The current-sense amplifier inputs are connected between IN and LX, so these pins must be connected as close as possible to the high-side MOSFET. The current-limit comparator inputs are connected between LX and GND, but accuracy is not as important, so give priority to the high-side MOSFET connections. The IN, LX, and GND connections to the MOSFETs must be made using Kelvin sense connections to guarantee current-sense and current-limit accuracy.
- 3) Group the gate-drive components (BST diode and capacitor, IN bypass capacitor) together near the MAX1864/MAX1865.
- 4) All analog grounding must be done to a separate solid copper ground plane, which connects to the MAX1864/MAX1865 at the GND pin. This includes the VL bypass capacitor, feedback resistors, compensation components (R_{COMP} , C_{COMP}), and adjustable current-limit threshold resistors connected to ILIM.

xDSL/Cable Modem Triple/Quintuple Output Power Supplies

- 5) Ensure all feedback connections are short and direct. Place the feedback resistors as close to the MAX1864/MAX1865 as possible.
- 6) When trade-offs in trace lengths must be made, it's preferable to allow the inductor charging path to be made longer than the discharge path. For example, it is better to allow some extra distance between the input capacitors and the high-side MOSFET than to allow distance between the inductor and low-side MOSFET or between the inductor and output filter capacitor.
- 7) Route high-speed switching nodes away from sensitive analog areas (B₋, FB₋, COMP, ILIM).

Regulating High Voltage

The linear regulator controllers can be configured to regulate high output voltages by adding a cascode transistor to buffer the base-drive output. For example, to generate an output voltage between 30V and 60V, add a 2N5550 high-voltage NPN transistor as shown in Figure 8a where V_{BIAS} is a DC voltage between 3V and 20V that can source at least 1mA. R_{DROP} protects the cascode transistor by decreasing the voltage across the transistor when the pass transistor saturates. Similarly, to regulate a negative output voltage between -20V and -120V, add a 2N5401 high-voltage PNP transistor as shown in Figure 8b.

Pin Configurations (continued)

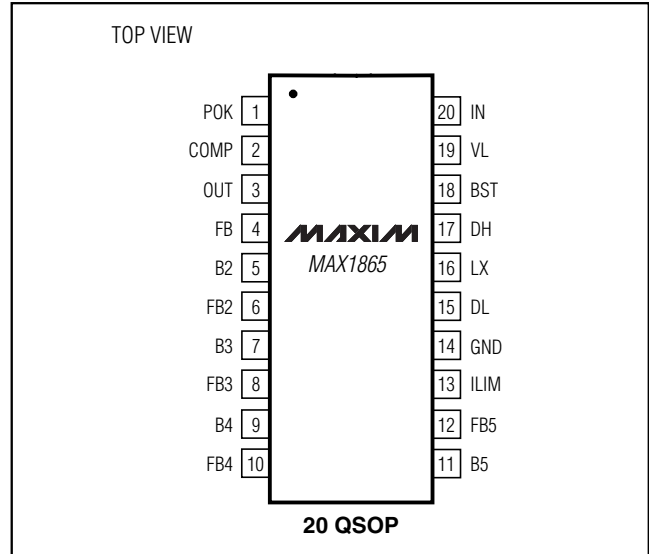

MAX1864/MAX1865

Chip Information

TRANSISTOR COUNT: 1617
 PROCESS: BiCMOS

xDSL/Cable Modem Triple/Quintuple Output Power Supplies

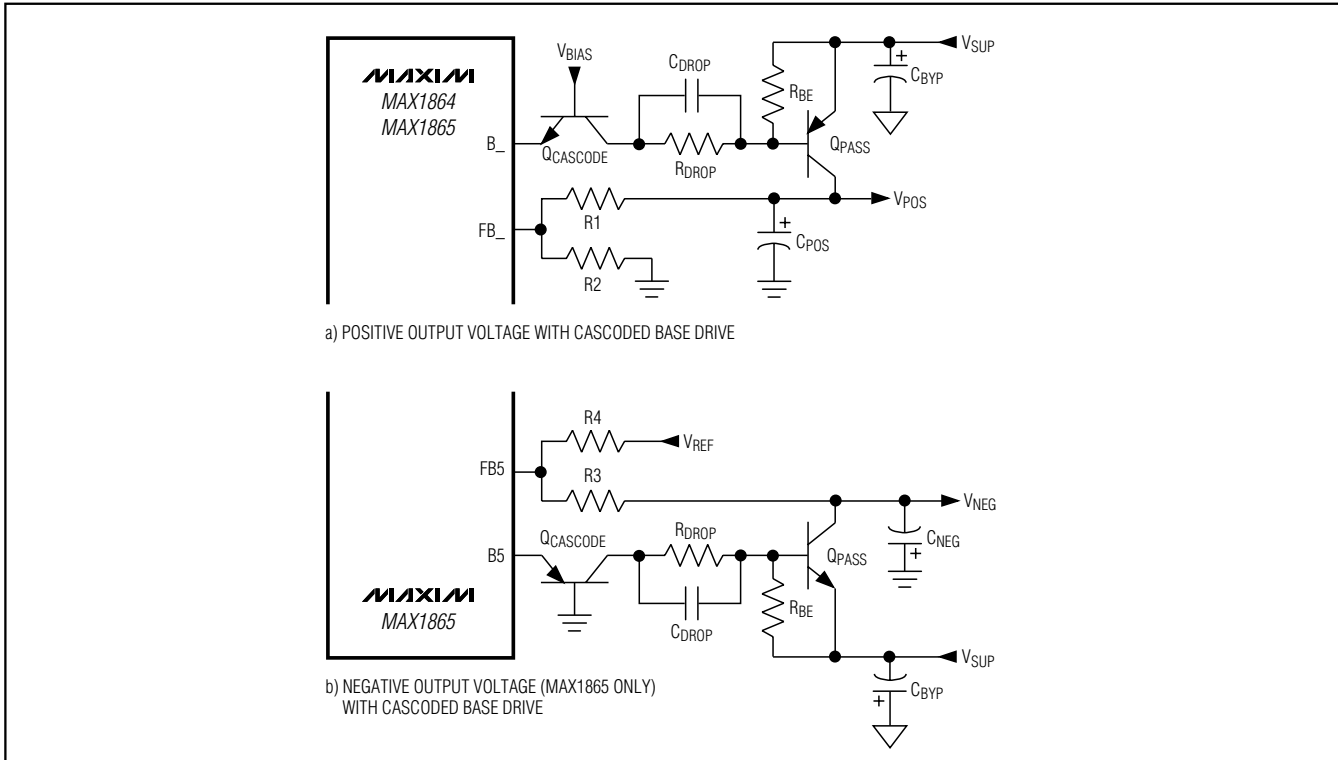

Figure 8. High-Voltage Linear Regulation

Table 1. Component Suppliers

SUPPLIER	PHONE	FAX	INTERNET
INDUCTORS AND TRANSFORMERS			
Coilcraft	847-639-6400	847-639-1469	http://www.coilcraft.com
Coiltronics	561-241-7876	561-241-9339	http://www.coiltronics.com
Sumida USA	847-956-0666	847-956-0702	http://www.sumida.com
Toko	847-297-0070	847-699-1194	http://www.toko.co.jp
CAPACITORS			
AVX	803-946-0690	803-626-3123	http://www.avxcorp.com
Kemet	408-986-0424	408-986-1442	http://www.kemet.com
Panasonic	847-468-5624	847-468-5815	http://www.panasonic.com
Sanyo	619-661-6835	619-661-1055	http://www.sanyo.com
Taiyo Yuden	408-573-4150	408-573-4159	http://www.t-yuden.com
DIODES			
Central Semiconductor	516-435-1110	516-435-1824	http://www.centalsemi.com
International	310-322-3331	310-322-3332	http://www.irf.com
Nihon	847-843-7500	847-843-2798	http://www.niec.co.jp
On Semiconductor	602-303-5454	602-994-6430	http://www.onsemi.com
Zetex	516-543-7100	516-864-7630	http://www.zetex.com

xDSL/Cable Modem Triple/Quintuple Output Power Supplies

Package Information

MAX1864/MAX1865

QSOP-EPS

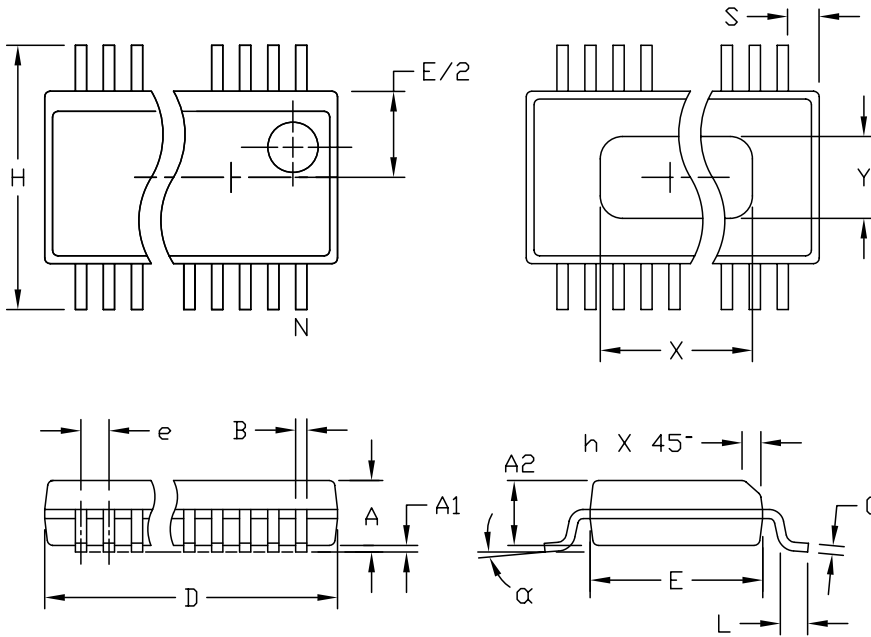

DIM	INCHES		MILLIMETERS	
	MIN	MAX	MIN	MAX
A	.061	.068	1.55	1.73
A1	.004	.0098	0.102	0.249
A2	.055	.061	1.40	1.55
B	.008	.012	0.20	0.31
C	.0075	.0098	0.191	0.249
D	SEE VARIATIONS			
E	.150	.157	3.81	3.99
e	.025 BSC		0.635 BSC	
H	.230	.244	5.84	6.20
h	.010	.016	0.25	0.41
L	.016	.035	0.41	0.89
N	SEE VARIATIONS			
X	SEE VARIATIONS			
Y	.071	.087	1.803	2.209
α	0°	8°	0°	8°

VARIATIONS:

DIM	INCHES		MILLIMETERS		N
	MIN.	MAX.	MIN.	MAX.	
D	.189	.196	4.80	4.98	16 AA
S	.0020	.0070	0.05	0.18	
X	.107	.123	2.72	3.12	
D	.337	.344	8.56	8.74	20 AB
S	.0500	.0550	1.270	1.397	
D	.337	.344	8.56	8.74	24 AC
S	.0250	.0300	0.635	0.762	
D	.386	.393	9.80	9.98	28 AD
S	.0250	.0300	0.635	0.762	
X	.271	.287	6.88	7.29	

NOTES:

1. D & E DO NOT INCLUDE MOLD FLASH OR PROTRUSIONS.
2. MOLD FLASH OR PROTRUSIONS NOT TO EXCEED .006" PER SIDE.
3. HEAT SLUG DIMENSIONS X AND Y APPLY ONLY TO 16 AND 28 LEAD POWER-QSOP PACKAGES.
4. CONTROLLING DIMENSIONS: INCHES.
5. MEETS JEDEC MO137.

MAXIM

PROPRIETARY INFORMATION

TITLE:
PACKAGE OUTLINE, QSOP, .150", .025" LEAD PITCH

APPROVAL	DOCUMENT CONTROL NO.	REV
	21-0055	C 1/1

Maxim cannot assume responsibility for use of any circuitry other than circuitry entirely embodied in a Maxim product. No circuit patent licenses are implied. Maxim reserves the right to change the circuitry and specifications without notice at any time.

Maxim Integrated Products, 120 San Gabriel Drive, Sunnyvale, CA 94086 408-737-7600 _____ 25

Компания «Life Electronics» занимается поставками электронных компонентов импортного и отечественного производства от производителей и со складов крупных дистрибьюторов Европы, Америки и Азии.

С конца 2013 года компания активно расширяет линейку поставок компонентов по направлению коаксиальный кабель, кварцевые генераторы и конденсаторы (керамические, пленочные, электролитические), за счёт заключения дистрибьюторских договоров

Мы предлагаем:

- Конкурентоспособные цены и скидки постоянным клиентам.
- Специальные условия для постоянных клиентов.
- Подбор аналогов.
- Поставку компонентов в любых объемах, удовлетворяющих вашим потребностям.
- Приемлемые сроки поставки, возможна ускоренная поставка.
- Доставку товара в любую точку России и стран СНГ.
- Комплексную поставку.
- Работу по проектам и поставку образцов.
- Формирование склада под заказчика.
- Сертификаты соответствия на поставляемую продукцию (по желанию клиента).
- Тестирование поставляемой продукции.
- Поставку компонентов, требующих военную и космическую приемку.
- Входной контроль качества.
- Наличие сертификата ISO.

В составе нашей компании организован Конструкторский отдел, призванный помогать разработчикам, и инженерам.

Конструкторский отдел помогает осуществить:

- Регистрацию проекта у производителя компонентов.
- Техническую поддержку проекта.
- Защиту от снятия компонента с производства.
- Оценку стоимости проекта по компонентам.
- Изготовление тестовой платы монтаж и пусконаладочные работы.



Тел: +7 (812) 336 43 04 (многоканальный)

Email: org@lifeelectronics.ru