

### DESCRIPTION

The MP3305 is a monolithic step-up converter designed for driving arrays of WLEDs from 5V input or a single cell Lithium Ion battery. The MP3305 uses current mode, fixed frequency architecture to regulate the LED current, which is measured through an external current sense resistor. Its low 200mV feedback voltage reduces power loss and improves efficiency.

The MP3305 features up to 50kHz true PWM dimming, which allows the flexible control of the backlighting luminance under wide range of the ambient brightness, and also avoids the possibility of PWM dimming audible noise.

The MP3305 is turned off if an over-voltage condition is present due to an open circuit condition. Use one external resistor voltage divider to adjust OVP threshold. MP3305 also includes under-voltage lockout, current limiting and thermal overload protection preventing damage in the event of an output overload.

The MP3305 is available in small 8-pin QFN 2x3mm package.

### FEATURES

- Internal Power MOSFET
- Drives up to 10 Series White LEDs
- Up to 88% Efficiency
- PWM Dimming Frequency from 250Hz to 50kHz
- 2.2MHz Fixed Switching Frequency
- Adjustable Open Load Shutdown Threshold (OVP)
- Low 200mV Feedback Voltage
- UVLO, Thermal Shutdown
- Internal 1.3A Current Limit
- Available in 2mm x 3mm QFN8 Package

### APPLICATIONS

- LCD Panels
- Digital Picture Frames
- Handheld Computers and PDAs
- Digital Still Cameras
- Small LCD Displays

All MPS parts are lead-free and adhere to the RoHS directive. For MPS green status, please visit MPS website under Quality Assurance. "Monolithic Power Systems", "MPS", and "The Future of Analog IC Technology" are Registered Trademarks of Monolithic Power Systems, Inc.

### TYPICAL APPLICATION



V<sub>IN</sub> vs. Efficiency

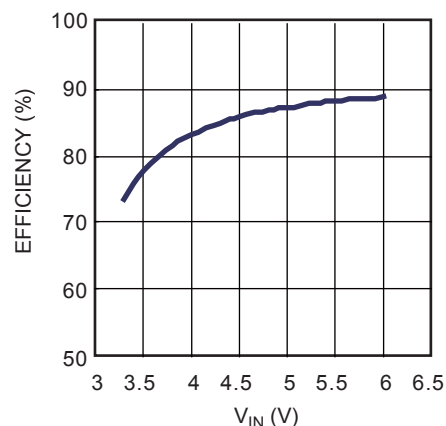

## ORDERING INFORMATION

Part Number*	Package	Top Marking	Free Air Temperature (T <sub>A</sub> )
MP3305DD	QFN8 (2mm x 3mm)	6E	-40°C to +85°C

\* For Tape & Reel, add suffix -Z (e.g. MP3305DD-Z).  
 For RoHS compliant packaging, add suffix -LF (e.g. MP3305DD-LF-Z)

## PACKAGE REFERENCE



### ABSOLUTE MAXIMUM RATINGS <sup>(1)</sup>

SW Pin, LED Pin.....	-0.5V to +40V
All Other Pins.....	-0.3V to +6.5V
Storage Temperature.....	-55°C to +150°C
Continuous Power Dissipation (T <sub>A</sub> = +25°C) <sup>(2)</sup>	1.9W

### Recommended Operating Conditions <sup>(3)</sup>

IN Supply Voltage.....	3V to 6V
SW Pin.....	V <sub>IN</sub> to 36V
Operating Junct. Temp (T <sub>J</sub> ).....	-40°C to +125°C

<i>Thermal Resistance</i> <sup>(4)</sup>	$\theta_{JA}$	$\theta_{JC}$
QFN8 (2mm x 3mm) .....	65	13 ... °C/W

#### Notes:

- 1) Exceeding these ratings may damage the device.
- 2) The maximum allowable power dissipation is a function of the maximum junction temperature T<sub>J</sub> (MAX), the junction-to-ambient thermal resistance  $\theta_{JA}$ , and the ambient temperature T<sub>A</sub>. The maximum allowable continuous power dissipation at any ambient temperature is calculated by P<sub>D</sub> (MAX) = (T<sub>J</sub> (MAX)-T<sub>A</sub>)/ $\theta_{JA}$ . Exceeding the maximum allowable power dissipation will cause excessive die temperature, and the regulator will go into thermal shutdown. Internal thermal shutdown circuitry protects the device from permanent damage.
- 3) The device is not guaranteed to function outside of its operating conditions.
- 4) Measured on JESD51-7, 4-layer PCB.

## ELECTRICAL CHARACTERISTICS

$V_{IN} = V_{EN} = 5V$ ,  $T_A = +25^{\circ}C$ , unless otherwise noted.

Parameters	Symbol	Condition	Min	Typ	Max	Units
Operating Input Voltage	$V_{IN}$		2.5		6	V
Supply Current (Shutdown)	$I_{IN\_SD}$	$V_{EN} = 0V$		1	2	$\mu A$
Supply Current (Quiescent)	$I_{IN\_QS}$	$V_{ISET} = 0.3V$		690	850	$\mu A$
Switching Frequency	$F_{SW}$		1.7	2.2	2.7	MHz
Maximum Duty Cycle	$D_{MAX}$	$V_{ISET} = 0V$	90			%
<b>Under Voltage Lockout</b>						
IN Under Voltage Lockout	$V_{UVLO}$	$V_{IN}$ Rising		2.25	2.45	V
Under Voltage Lockout Hysteresis				92		mV
Open Lamp Shutdown Threshold	$V_{OVP}$	$V_{OV}$ Rising		0.9		V
<b>Enable</b>						
EN OFF Threshold	$V_{EN\_LOW}$	$V_{EN}$ Falling	0.4			V
EN ON Threshold	$V_{EN\_HIGH}$	$V_{EN}$ Rising			1.8	V
Disable Timer				5		ms
Minimum EN ON Pulse				5		$\mu s$
<b>Feedback</b>						
ISET Voltage	$V_{ISET}$	$V_{EN} > 2V$	185	200	215	mV
ISET Input Bias Current		$V_{ISET} = 0.2V$	-600	-300		nA
<b>Output Switch</b>						
SW On-Resistance	$R_{ON}$			0.4		$\Omega$
SW Current Limit		Duty Cycle = 60%		1.33		A
Thermal Shutdown				150		$^{\circ}C$
LED Switch (M2, refer block diagram) On Resistance				0.8		$\Omega$

## PIN FUNCTIONS

QFN8 Pin #	Name	Pin Function
1	SW	Power Switch Output. SW is the drain of the internal MOSFET switch. Connect the power inductor and output rectifier to SW. SW can swing between GND and 36V.
2,8	GND, Exposed Pad	Ground. Connect exposed pad to GND plane for proper thermal performance.
3	IN	Input Supply Pin. Must be locally bypassed.
4	OVP	Open Load Protection Adjusting pin. Connect a resistor divider from output to this pin to adjust the OVP threshold. When this pin voltage reaches the shutdown threshold 0.9V, the switch will be turned off
5	EN	ON/OFF Control and Dimming Command Input. Holding EN pin low for more than 5ms will turn the part off. To use PWM dimming, add a 250Hz to 50KHz square wave signal to this pin.
6	LED	LED Current Input. This pin is the open-drain output of an internal dimming control switch. Connect the LED cathode to this pin.
7	ISET	LED Current Set. This pin is the source output of an internal dimming control switch. The MP3305 regulates the voltage across the current setting resistor. Tie a current setting resistor from this pin to ground. The regulation voltage is 200mV.

## TYPICAL PERFORMANCE CHARACTERISTICS

$V_{IN} = 5V$ ,  $I_{LED} = 200mA$ , 3WLEDs 10Strings, unless otherwise noted.

**$V_{IN}$  vs. Efficiency**



**PWM Dimming Duty vs. WLED Current**



**Steady State Operation**



**Enable Startup**

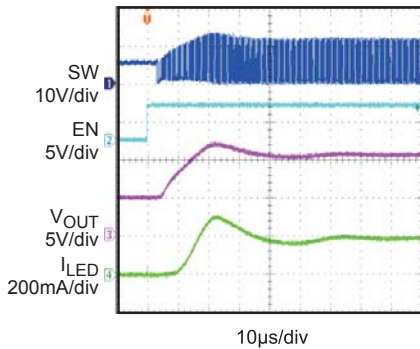

**Enable Shutdown**



**PWM Dimming**

$f_{PWM} = 50kHz$ , DPWM=50%

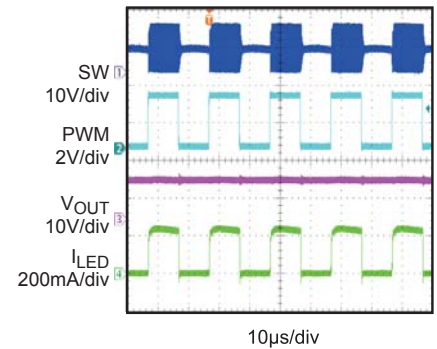

**Open Load Protection**

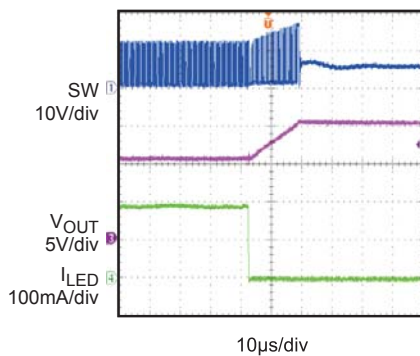

## OPERATION

The MP3305 uses a constant frequency, peak current mode boost regulator architecture to regulate the series string of white LEDs. The operation of the MP3305 can be understood by referring to the block diagram of Figure 1.

At the start of each oscillator cycle the FET is turned on through the control circuitry. To prevent sub-harmonic oscillations at duty cycles greater than 50 percent, a stabilizing ramp is added to the output of the current sense amplifier and the result is fed into the positive input of the PWM comparator. When this voltage equals the output voltage of the error amplifier the power FET is turned off.

The voltage at the output of the error amplifier is an amplified version of the difference between the 200mV reference voltage and the feedback voltage. In this way the peak current level keeps the output in regulation.

If the feedback voltage starts to drop, the output of the error amplifier increases. This results in more current flowing through the power FET, thus increasing the power delivered to the output.



**Figure 1—Functional Block Diagram**

## APPLICATION INFORMATION

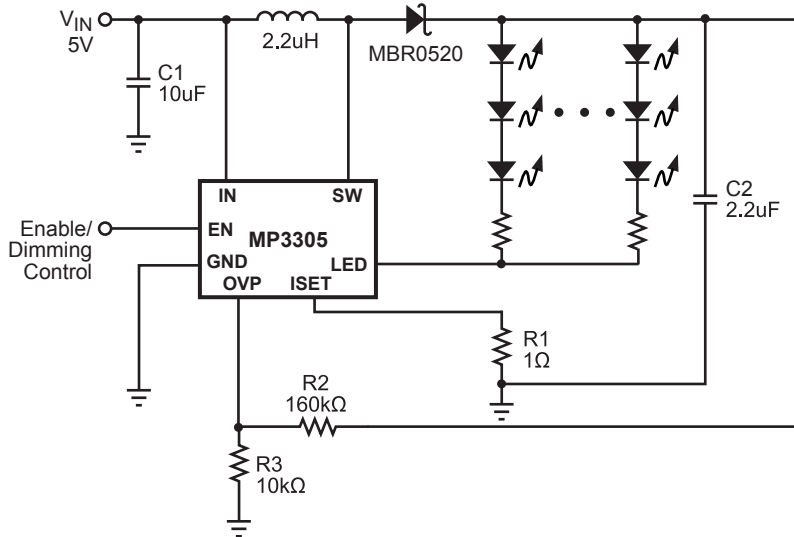

**Figure 2—Circuit for Driving 10 Strings of 3 WLEDs**

A typical application circuit can be seen in Figure 2. The 10 strings of 3 white LEDs can be driven from a 5V at an output current of 200mA. A 2.2µF output capacitor is sufficient for most applications. A 2.2µH inductor with low DCR (Inductor DC resistance) is recommended to improve efficiency. A 10µF ceramic capacitor is recommended for the input capacitance in the real system. Schottky diodes have fast recovery and a low forward voltage are recommended. Schottky diodes rated with 500mA are sufficient for the MP3305. The MP3305 has internal soft-start to limit the amount of current through VIN at startup and to also limit the amount of overshoot on the output.

The ramped voltage that is added to the current sense amplifier reduces the current output as the duty cycle increases. As more LEDs are added, the output voltage rises but the current that can be delivered to the load is reduced as well.

### Setting the LED Current

The LED current is controlled by the current setting resistor, R1. The current through the LEDs is given by:  $I_{LED} = 200\text{mV}/R1$ .

Table 1 shows the selection of resistors for a given LED current.

**Table 1— $I_{LED}$  vs. R1**

$I_{LED}$ (mA)	R1 ( $\Omega$ )
1	200
5	40
10	20
20	10
60	3.33
180	1.11
200	1

### PWM Dimming

Apply a 250Hz to 50kHz square waveform to the EN pin to implement PWM dimming of the LEDs. The minimum recommended amplitude of the PWM signal is 2V.

### Open Load Protection

Open Load protection will shut off the MP3305 if the output voltage goes too high. In some cases an LED may fail, this will result in the feedback voltage always being zero. The part will run at maximum duty cycle boosting the output voltage higher and higher. If the output voltage ever exceeds the adjusted OVP threshold

( $V_{OV} = 0.9V(1 + \frac{R2}{R3})$ ), the MP3305 will shut down.

The part will not switch again until the power is recycled.

**Layout Considerations**

Careful attention must be paid to the PCB board layout and components placement. Proper layout of the high frequency switching path is critical to prevent noise and electromagnetic interference problems. The loop of MP3305 SW to GND pin, output diode, and output capacitor is flowing with high frequency ripple current, it must be as short as possible. And connect the GND (2 pin) and PGND (8 pin) together thru thermal pad, as showed in Figure 3.

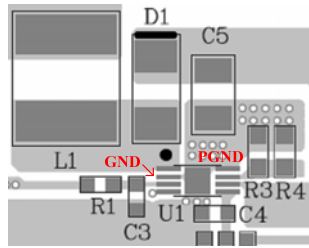

**Figure 3—Layout consideration**

The IN pin of the IC must be locally bypassed. A RC filter is highly recommended for eliminating the noise on IN pin. It could be implemented as shown in Figure 4.



**Figure 4—Input Bias Filtering**



## TYPICAL APPLICATION CIRCUITS

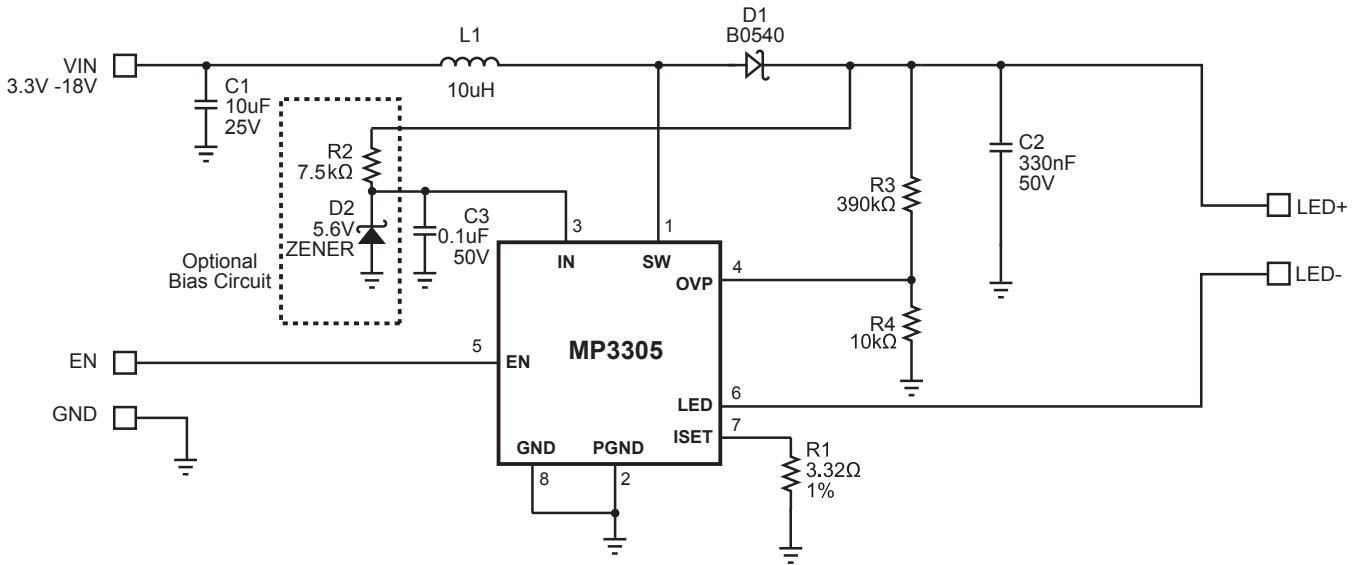

**Figure 5 — Driving 27 WLEDs (9 WLEDs in Series and 3 Strings Paralleled) with 3.3V-18V Input Voltage**

In order to improve the MOSFET on-resistance at low input voltage and make the chip compatible for high input voltage, the additional bias circuit should be used.

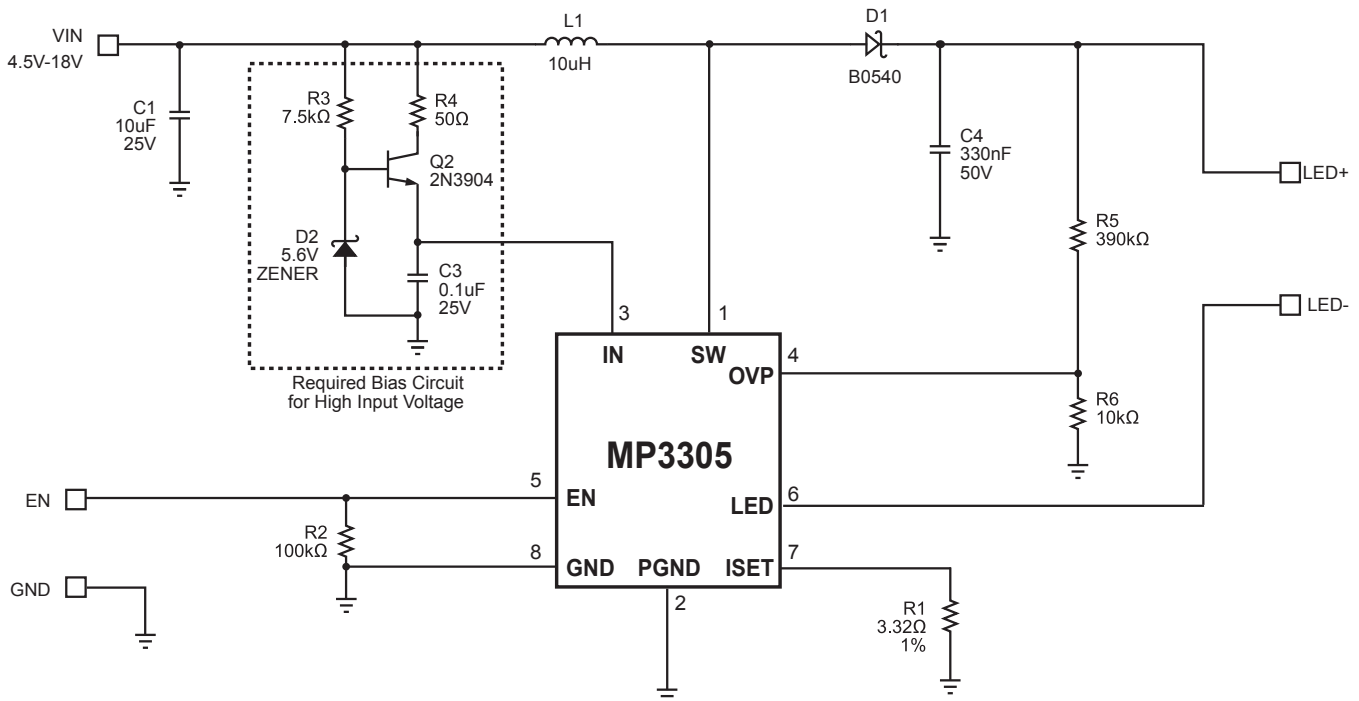

**Figure 6 — Wide Input Voltage Step-up Converter for 27 WLEDs (9 WLEDs in Series and 3 Strings Paralleled)**

**TYPICAL APPLICATION CIRCUITS** (continued)



**Figure 7 — Driving 10 WLEDs in Series with 5V Input Voltage**



Компания «Life Electronics» занимается поставками электронных компонентов импортного и отечественного производства от производителей и со складов крупных дистрибьюторов Европы, Америки и Азии.

С конца 2013 года компания активно расширяет линейку поставок компонентов по направлению коаксиальный кабель, кварцевые генераторы и конденсаторы (керамические, пленочные, электролитические), за счёт заключения дистрибьюторских договоров

Мы предлагаем:

- Конкурентоспособные цены и скидки постоянным клиентам.
- Специальные условия для постоянных клиентов.
- Подбор аналогов.
- Поставку компонентов в любых объемах, удовлетворяющих вашим потребностям.
- Приемлемые сроки поставки, возможна ускоренная поставка.
- Доставку товара в любую точку России и стран СНГ.
- Комплексную поставку.
- Работу по проектам и поставку образцов.
- Формирование склада под заказчика.
- Сертификаты соответствия на поставляемую продукцию (по желанию клиента).
- Тестирование поставляемой продукции.
- Поставку компонентов, требующих военную и космическую приемку.
- Входной контроль качества.
- Наличие сертификата ISO.

В составе нашей компании организован Конструкторский отдел, призванный помогать разработчикам, и инженерам.

Конструкторский отдел помогает осуществить:

- Регистрацию проекта у производителя компонентов.
- Техническую поддержку проекта.
- Защиту от снятия компонента с производства.
- Оценку стоимости проекта по компонентам.
- Изготовление тестовой платы монтаж и пусконаладочные работы.



Тел: +7 (812) 336 43 04 (многоканальный)  
Email: [org@lifeelectronics.ru](mailto:org@lifeelectronics.ru)