

LOC	DIST	REV	DESCRIPTION	DATE	BY	APPV
		D	REV PER ECO-07-017102	20SEP07	PY	BW

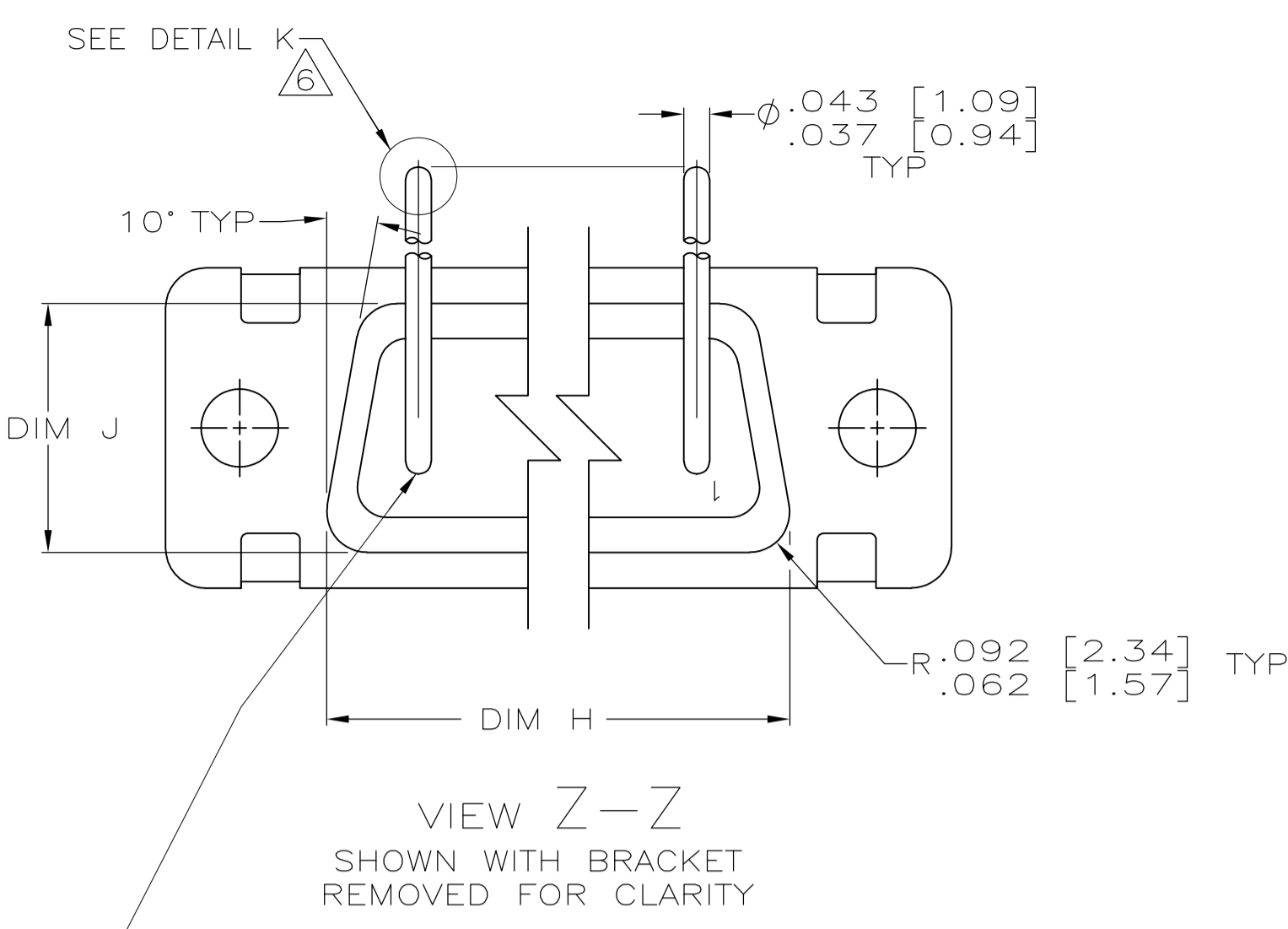

CONTACT (QTY = NO. OF POSN)
 MATL: BRASS PER ASTM-B-16, OR BERYLLIUM COPPER PER ASTM-B-194
 FINISH: GOLD PER MIL-G-45204, TYPE II, GRADE C, CLASS 1 IN CONTACT MATING AREA, .000010 [0.0003] MIN THK GOLD PER MIL-G-45204 OVER .000050 [0.0013] MIN THK NICKEL PER QQ-N-290 ON CONTACT BODY

- 1. SEE SHEET 2 FOR RECOMMENDED P.C. BOARD LAYOUT. TRUE POSITION TOLERANCE FOR P.C. BOARD LAYOUT IS .010 [0.25] AT MAX MATERIAL CONDITION. SUGGESTED BOARD THICKNESS IS .125 [3.18]
- 2. THE CONNECTORS DESCRIBED IN THIS DOCUMENT MEET THE REQUIREMENTS OF MIL-C-24308 AND MATE WITH ANY PLUG CONNECTOR WITH SAME INSERT ARRANGEMENT.
- 3. MARKED WITH .047 [1.19]-.062 [1.57] HIGH CHARACTERS. FAR SIDE REFERS TO THE WIDE SIDE OF THE KEYSTONE. NEAR SIDE REFERS TO THE NARROW SIDE OF THE KEYSTONE. IF THE REAR SHELL IS TOO SMALL FOR THE ENTIRE MILITARY PART NUMBER, MARKING SHALL BE LOCATED AS FOLLOWS:
 - A. "M24308" ON FRONT SHELL, FAR SIDE.
 - B. SLASH SHEET AND DASH NUMBER ON REAR SHELL, FAR SIDE.
 - C. "AMP" AND DATE CODE ON FRONT SHELL, NEAR SIDE.
 - D. AMP PART NUMBER ON REAR SHELL, NEAR SIDE.
- IF THE FRONT SHELL IS TOO SMALL FOR "AMP", AMP PART NUMBER AND DATE CODE, MARKING SHALL BE SPLIT AS FOLLOWS:
 - A. AMP PART NUMBER ON REAR SHELL, NEAR SIDE.
 - B. "AMP" AND DATE CODE ON FRONT SHELL, NEAR SIDE.
 - C. MILITARY PART NUMBER ON REAR SHELL, FAR SIDE.
- 4. POINT OF ELECTRICAL ENGAGEMENT - AS MEASURED WITH A .0390 [0.991]-.0393 [0.998] DIA SQUARE ENDED TEST PIN.
- 5. THIS DRAWING SHALL BE INTERPRETED IN ACCORDANCE WITH APPLICABLE STANDARDS LISTED IN MIL-STD-100.
- 6. SOLDER DIP PER MIL-STD-2000 COMPOSITION Sn63 CONFORMING TO QQ-S-571 IN THE ENTIRE AREA OF DIMENSION SHOWN. 1218435-6 THRU -10 ONLY.

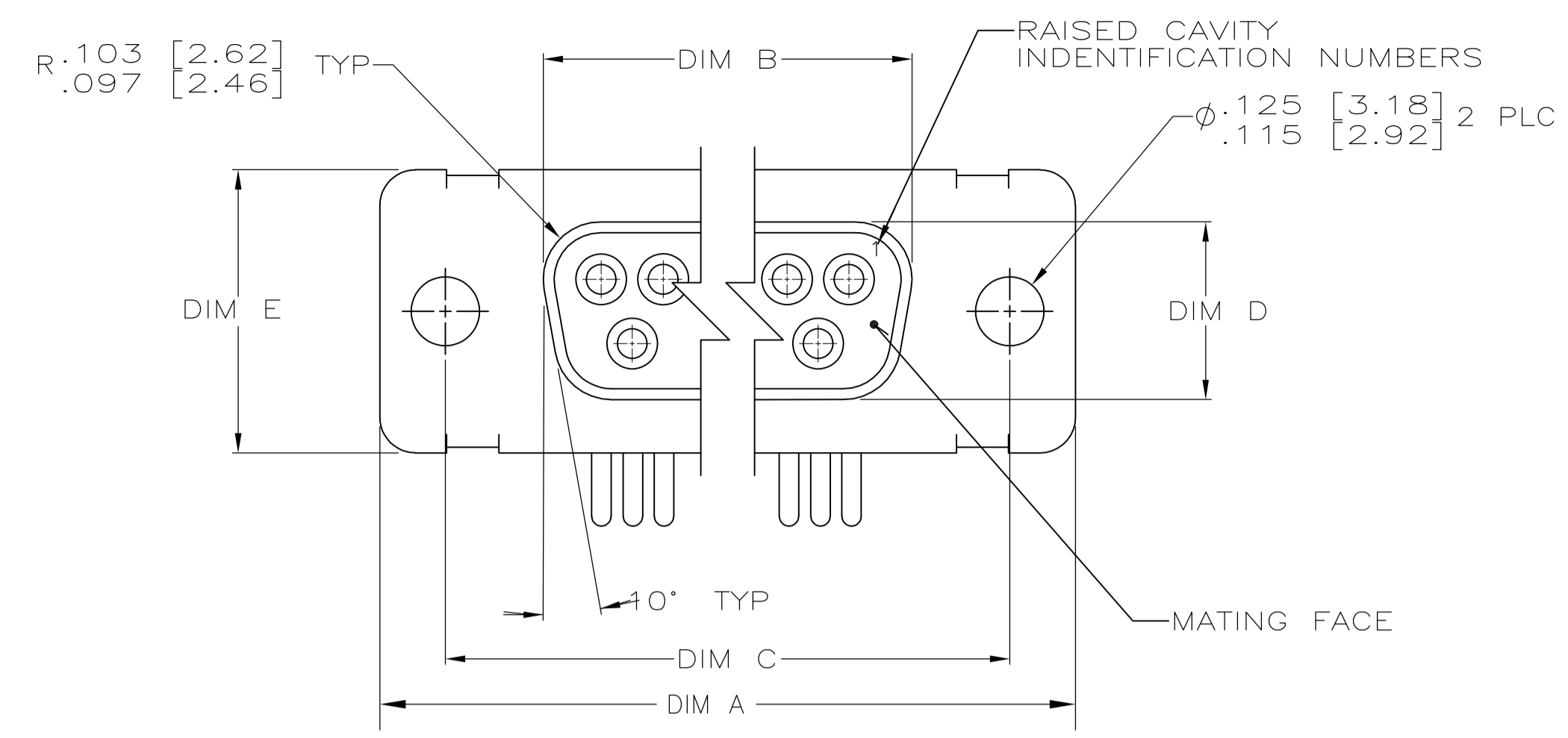
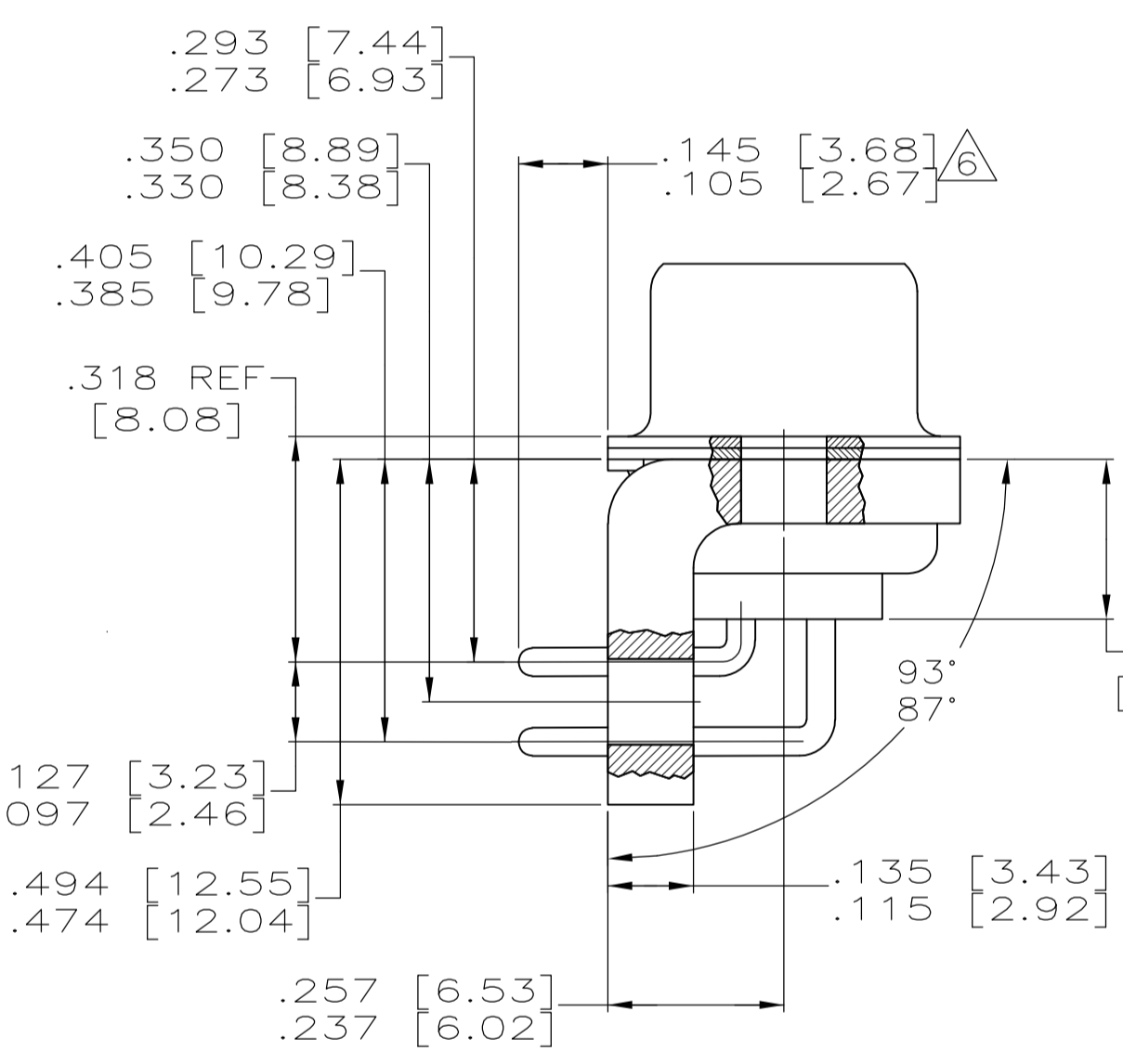
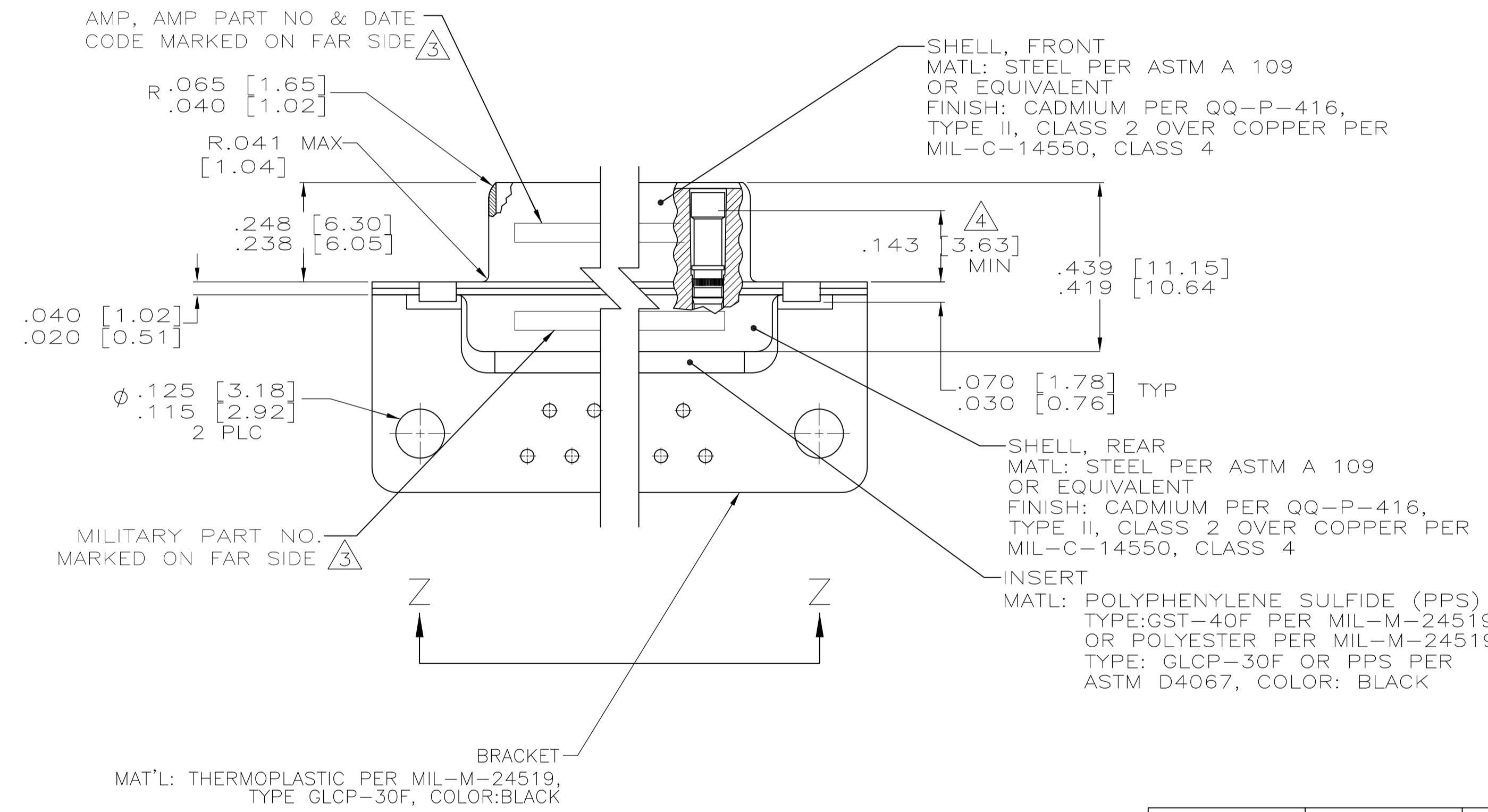

SHELL SIZES 1 THRU 4 CONTACT CONFIGURATION

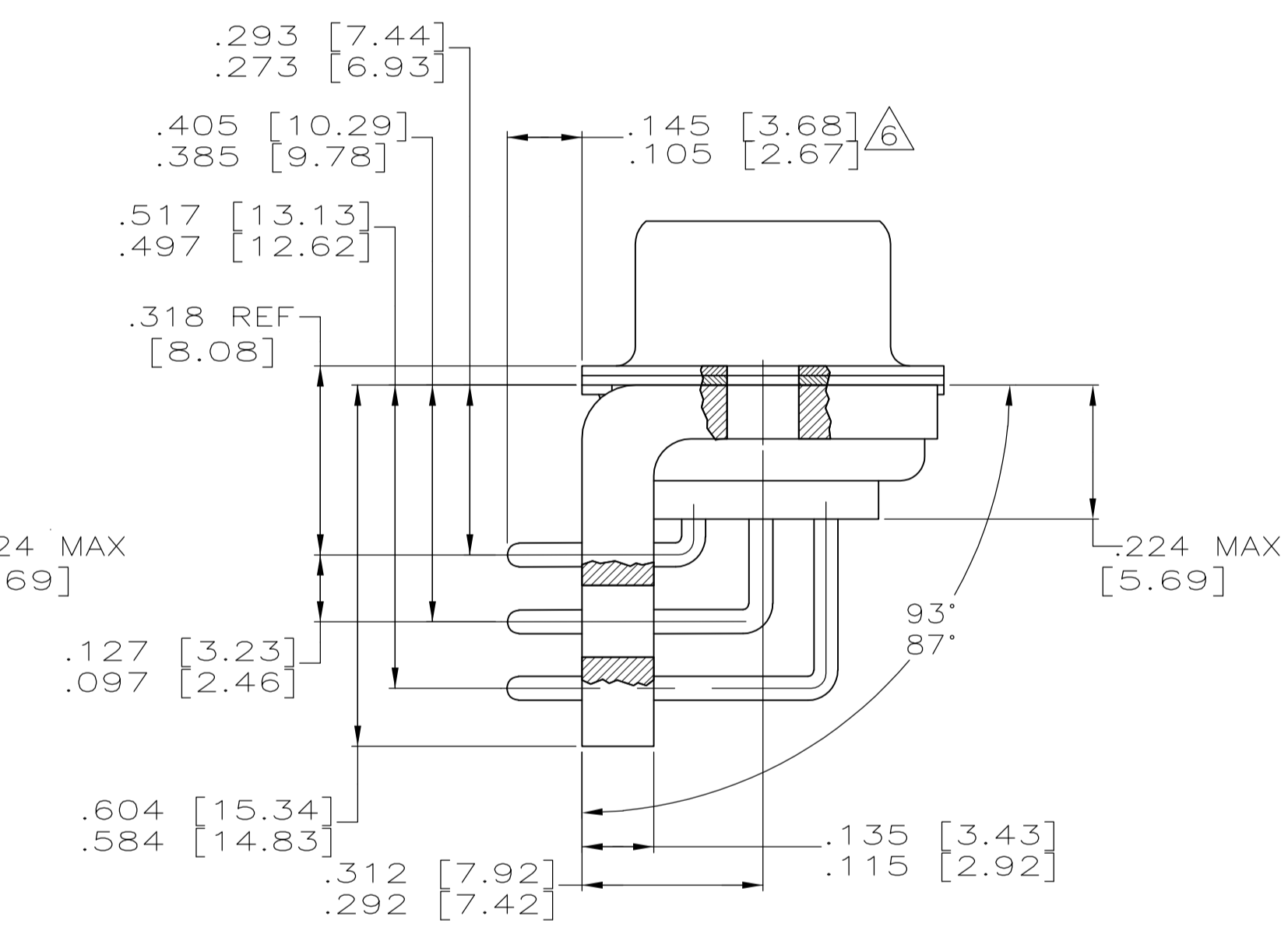

SHELL SIZE 5 CONTACT CONFIGURATION

.544 [13.82]	2.188 [55.58]	.620 [15.75]	.428 [10.87]	2.411 [61.24]	2.069 [52.55]	2.650 [67.31]
.524 [13.31]	2.168 [55.07]	.590 [14.99]	.418 [10.62]	2.401 [60.99]	2.059 [52.30]	2.620 [66.55]
.432 [10.97]	2.282 [57.96]	.509 [12.93]	.316 [8.03]	2.505 [63.63]	2.164 [54.97]	2.744 [69.70]
.412 [10.46]	2.262 [57.45]	.479 [12.17]	.306 [7.77]	2.495 [63.37]	2.154 [54.71]	2.714 [68.94]
.432 [10.97]	1.635 [41.53]	.509 [12.93]	.316 [8.03]	1.857 [47.17]	1.516 [38.51]	2.103 [53.42]
.412 [10.46]	1.615 [41.02]	.479 [12.17]	.306 [7.77]	1.847 [46.91]	1.506 [38.25]	2.073 [52.65]
.432 [10.97]	1.093 [27.76]	.509 [12.93]	.316 [8.03]	1.317 [33.45]	.976 [24.79]	1.556 [39.52]
.412 [10.46]	1.073 [27.25]	.479 [12.17]	.306 [7.77]	1.307 [33.20]	.966 [24.54]	1.526 [38.76]
.432 [10.97]	.769 [19.53]	.509 [12.93]	.316 [8.03]	.989 [25.12]	.648 [16.46]	1.228 [31.19]
.412 [10.46]	.749 [19.02]	.479 [12.17]	.306 [7.77]	.979 [24.87]	.638 [16.21]	1.198 [30.43]
.544 [13.82]	2.188 [55.58]	.620 [15.75]	.428 [10.87]	2.411 [61.24]	2.069 [52.55]	2.650 [67.31]
.524 [13.31]	2.168 [55.07]	.590 [14.99]	.418 [10.62]	2.401 [60.99]	2.059 [52.30]	2.620 [66.55]
.432 [10.97]	2.282 [57.96]	.509 [12.93]	.316 [8.03]	2.505 [63.63]	2.164 [54.97]	2.744 [69.70]
.412 [10.46]	2.262 [57.45]	.479 [12.17]	.306 [7.77]	2.495 [63.37]	2.154 [54.71]	2.714 [68.94]
.432 [10.97]	1.635 [41.53]	.509 [12.93]	.316 [8.03]	1.857 [47.17]	1.516 [38.51]	2.103 [53.42]
.412 [10.46]	1.615 [41.02]	.479 [12.17]	.306 [7.77]	1.847 [46.91]	1.506 [38.25]	2.073 [52.65]
.432 [10.97]	1.093 [27.76]	.509 [12.93]	.316 [8.03]	1.317 [33.45]	.976 [24.79]	1.556 [39.52]
.412 [10.46]	1.073 [27.25]	.479 [12.17]	.306 [7.77]	1.307 [33.20]	.966 [24.54]	1.526 [38.76]
.432 [10.97]	.769 [19.53]	.509 [12.93]	.316 [8.03]	.989 [25.12]	.648 [16.46]	1.228 [31.19]
.412 [10.46]	.749 [19.02]	.479 [12.17]	.306 [7.77]	.979 [24.87]	.638 [16.21]	1.198 [30.43]

DIM J	DIM H	DIM E	DIM D	DIM C	DIM B	DIM A	INSERT ARRANGEMENT	NO OF POS	SHELL SIZE	MILITARY P/N ON CONNECTOR	AMP P/N MARKED ON CONNECTOR	AMP PART NO.
.544	2.188	.620	.428	2.411	2.069	2.650	MS18277-1	50	5	M24308/23-41F	1218435-5	1-1218435-0
.524	2.168	.590	.418	2.401	2.059	2.620	MS18276-1	37	4	M24308/23-40F	1218435-4	1218435-9
.432	2.282	.509	.316	2.505	2.164	2.744	MS18275-1	25	3	M24308/23-39F	1218435-3	1218435-8
.412	2.262	.479	.306	2.495	2.154	2.714	MS18274-1	15	2	M24308/23-38F	1218435-2	1218435-7
.432	1.635	.509	.316	1.857	1.516	2.103	MS18273-1	9	1	M24308/23-37F	1218435-1	1218435-6
.412	1.615	.479	.306	1.847	1.506	2.073	MS18277-1	50	5	M24308/23-41F	1218435-5	1218435-5
.432	2.282	.509	.316	2.505	2.164	2.744	MS18276-1	37	4	M24308/23-40F	1218435-4	1218435-4
.412	2.262	.479	.306	2.495	2.154	2.714	MS18275-1	25	3	M24308/23-39F	1218435-3	1218435-3
.432	1.635	.509	.316	1.857	1.516	2.103	MS18274-1	15	2	M24308/23-38F	1218435-2	1218435-2
.412	1.615	.479	.306	1.847	1.506	2.073	MS18273-1	9	1	M24308/23-37F	1218435-1	1218435-1

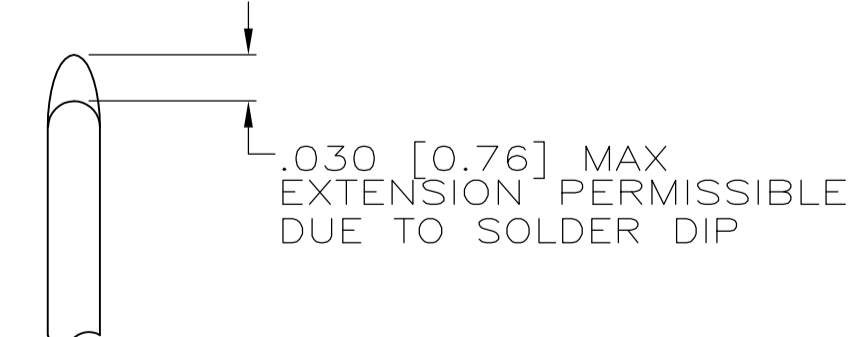

DETAIL K SCALE 8:1 FOR 1218435-6 THRU -10 ONLY

THIS DRAWING IS A CONTROLLED DOCUMENT.

DIMENSIONS: INCHES	TOLERANCES UNLESS OTHERWISE SPECIFIED:	DIN C.C. THOMAS 12-3-99	12-15-99	Tyco Electronics Corporation Harrisburg, PA 17105-3608
0 PLC ± .005	1 PLC ± .005	CHAD BAKER	12-15-99	NAME: RECEPTACLE ASSY, AMPLIMITE RIGHT ANGLE, SERIES 109 SIZES 1 THRU 5
2 PLC ± .005	3 PLC ± .010 [0.25]	CHAD BAKER	12-15-99	SIZE: A1
4 PLC ± .010	ANGLES ± 1°	PRODUCT SPEC	APPLICATION SPEC	WEIGHT: —
MATERIAL: SEE CALLOUTS	FINISH: SEE CALLOUTS	REVISIONS	DATE	RESTRICTED TO: —
		12-15-99	12-15-99	CUSTOMER DRAWING

SCALE 4:1 SHEET 1 OF 2 REV D

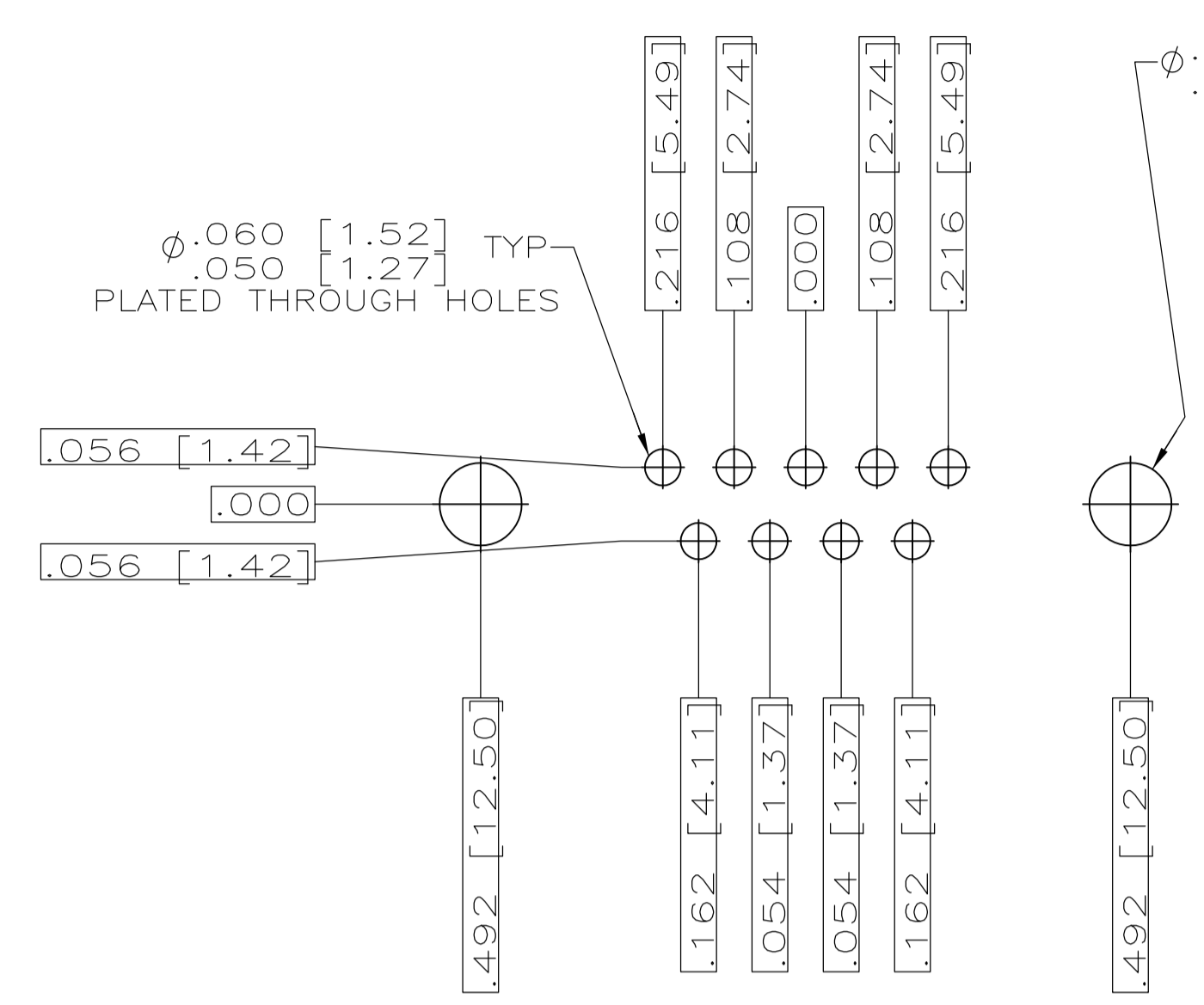

RECOMMENDED P.C. BOARD LAYOUT
SHELL SIZE 1 (9 POSITION)



RECOMMENDED P.C. BOARD LAYOUT
SHELL SIZE 2 (15 POSITION)



RECOMMENDED P.C. BOARD LAYOUT
SHELL SIZE 3 (25 POSITION)

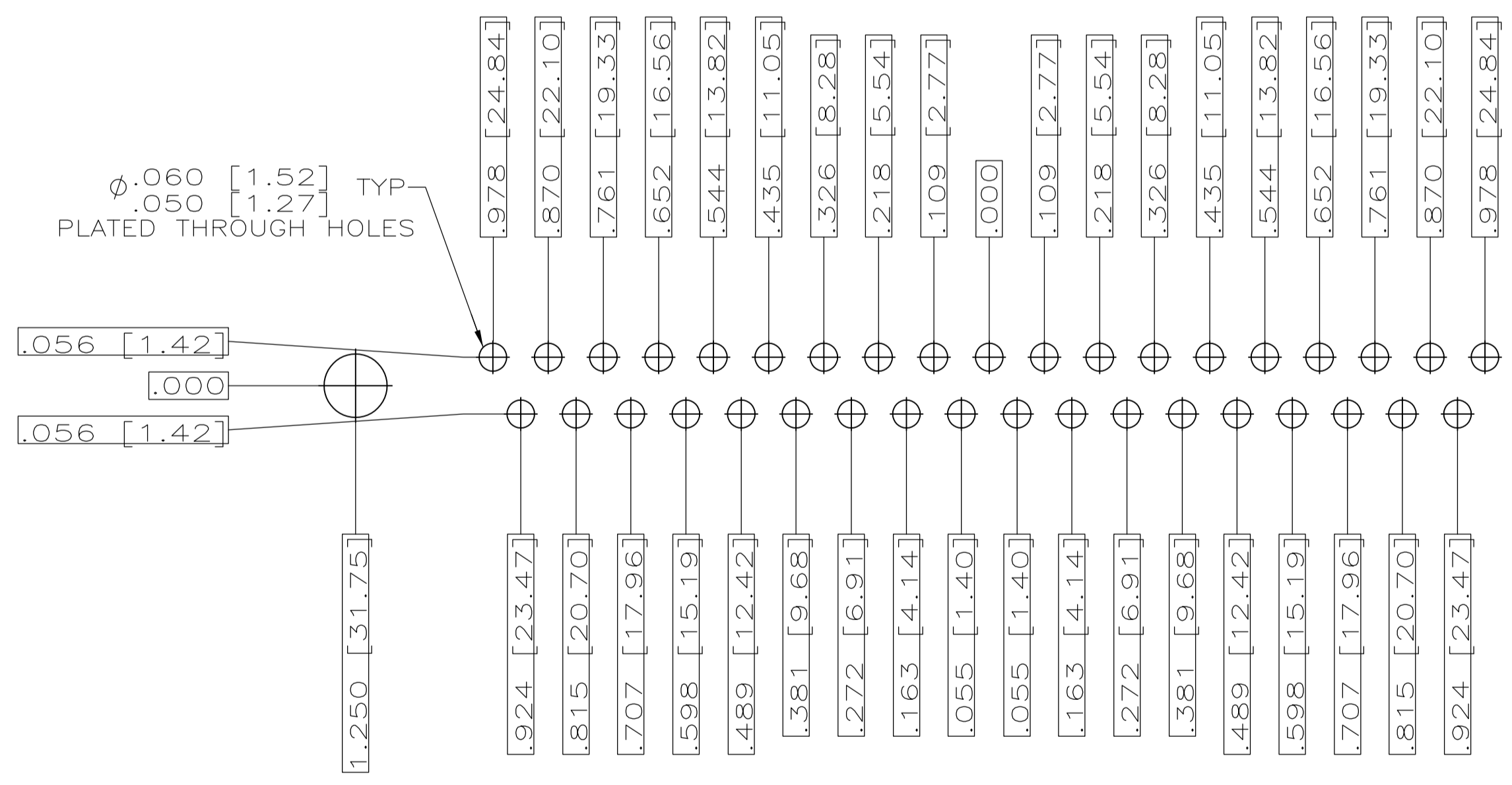

RECOMMENDED P.C. BOARD LAYOUT
SHELL SIZE 4 (37 POSITION)

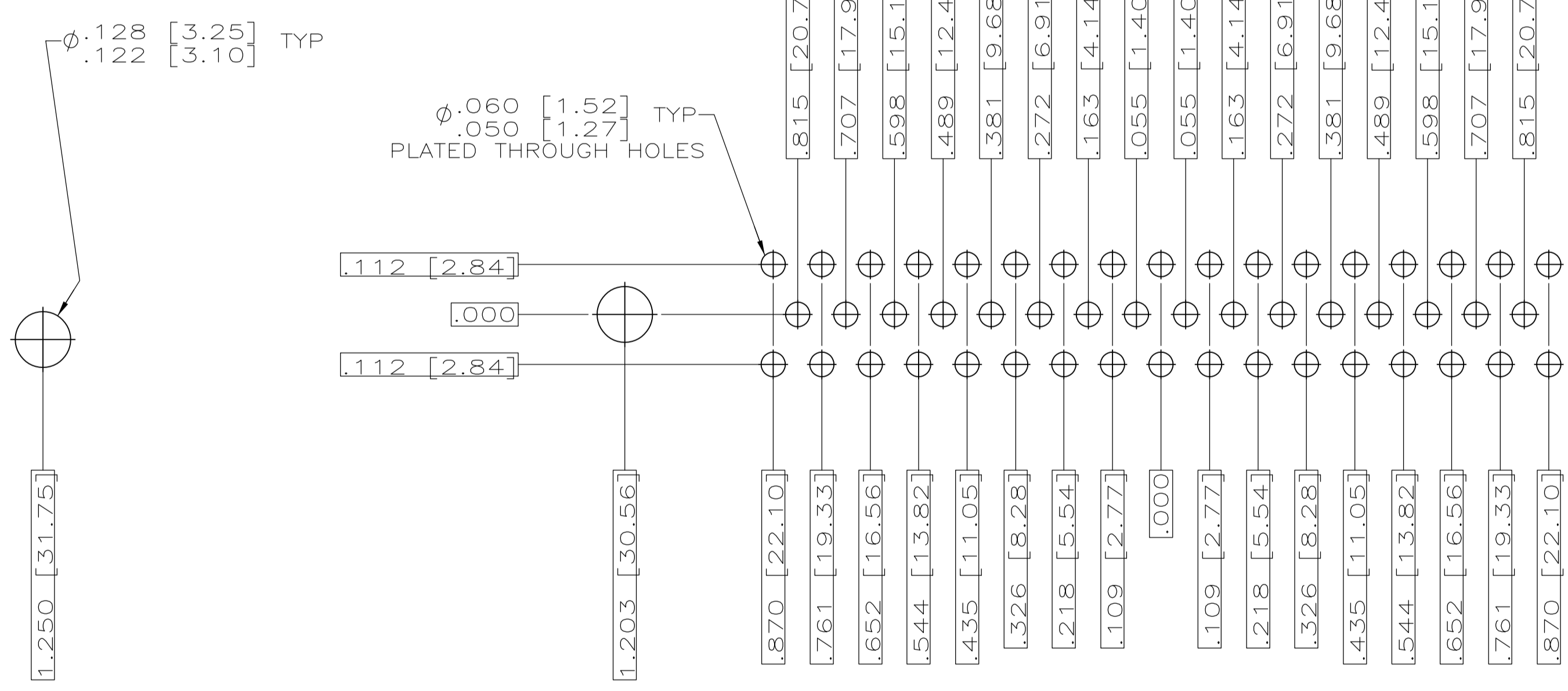

RECOMMENDED P.C. BOARD LAYOUT
SHELL SIZE 5 (50 POSITION)

THIS DRAWING IS A CONTROLLED DOCUMENT.		DWN C.C.THOMAS 12-6-99 CHK CHAD BAKER 12-15-99 APVD CHAD BAKER 12-15-99 PRODUCT SPEC APPLICATION SPEC WEIGHT CUSTOMER DRAWING	Tyco Electronics Corporation Harrisburg, PA 17105-3608 NAME RECEPTACLE ASSY,AMPLITE RIGHT ANGLE,SERIES 109,SIZE 1 THRU 5 SIZE A1 CAGE CODE 00779 DRAWING NO. 1218435 SCALE 4:1 SHEET 2 OF 2 REV D
DIMENSIONS: INCHES TOLERANCES UNLESS OTHERWISE SPECIFIED: 0 PL ± .010 1 PL ± .010 2 PL ± .010 3 PL ± .010 4 PL ± .010 ANGLES ± .4°	FINISH SEE CALLOUTS	RESTRICTED TO	

Компания «Life Electronics» занимается поставками электронных компонентов импортного и отечественного производства от производителей и со складов крупных дистрибьюторов Европы, Америки и Азии.

С конца 2013 года компания активно расширяет линейку поставок компонентов по направлению коаксиальный кабель, кварцевые генераторы и конденсаторы (керамические, пленочные, электролитические), за счёт заключения дистрибьюторских договоров

Мы предлагаем:

- Конкурентоспособные цены и скидки постоянным клиентам.
- Специальные условия для постоянных клиентов.
- Подбор аналогов.
- Поставку компонентов в любых объемах, удовлетворяющих вашим потребностям.
- Приемлемые сроки поставки, возможна ускоренная поставка.
- Доставку товара в любую точку России и стран СНГ.
- Комплексную поставку.
- Работу по проектам и поставку образцов.
- Формирование склада под заказчика.
- Сертификаты соответствия на поставляемую продукцию (по желанию клиента).
- Тестирование поставляемой продукции.
- Поставку компонентов, требующих военную и космическую приемку.
- Входной контроль качества.
- Наличие сертификата ISO.

В составе нашей компании организован Конструкторский отдел, призванный помогать разработчикам, и инженерам.

Конструкторский отдел помогает осуществить:

- Регистрацию проекта у производителя компонентов.
- Техническую поддержку проекта.
- Защиту от снятия компонента с производства.
- Оценку стоимости проекта по компонентам.
- Изготовление тестовой платы монтаж и пусконаладочные работы.



Тел: +7 (812) 336 43 04 (многоканальный)

Email: org@lifeelectronics.ru