



XC9536 In-System Programmable CPLD

DS064 (v7.0) May 17, 2013

Product Specification

Features

- 5 ns pin-to-pin logic delays on all pins
- f_{CNT} to 100 MHz
- 36 macrocells with 800 usable gates
- Up to 34 user I/O pins
- 5V in-system programmable
 - Endurance of 10,000 program/erase cycles
 - Program/erase over full commercial voltage and temperature range
- Enhanced pin-locking architecture
- Flexible 36V18 Function Block
 - 90 product terms drive any or all of 18 macrocells within Function Block
 - Global and product term clocks, output enables, set and reset signals
- Extensive IEEE Std 1149.1 boundary-scan (JTAG) support
- Programmable power reduction mode in each macrocell
- Slew rate control on individual outputs
- User programmable ground pin capability
- Extended pattern security features for design protection
- High-drive 24 mA outputs
- 3.3V or 5V I/O capability
- Advanced CMOS 5V FastFLASH™ technology
- Supports parallel programming of more than one XC9500 concurrently
- Available in 44-pin PLCC, 44-pin VQFP, 48-pin CSP packages

Description

The XC9536 is a high-performance CPLD providing advanced in-system programming and test capabilities for general purpose logic integration. It is comprised of eight 36V18 Function Blocks, providing 800 usable gates with propagation delays of 5 ns. See [Figure 2](#) for the architecture overview.

Power Management

Power dissipation can be reduced in the XC9536 by configuring macrocells to standard or low-power modes of operation. Unused macrocells are turned off to minimize power dissipation.

Operating current for each design can be approximated for specific operating conditions using the following equation:

$$I_{CC} \text{ (mA)} = MC_{HP} (1.7) + MC_{LP} (0.9) + MC (0.006 \text{ mA/MHz}) f$$

Where:

MC_{HP} = Macrocells in high-performance mode

MC_{LP} = Macrocells in low-power mode

MC = Total number of macrocells used

f = Clock frequency (MHz)

[Figure 1](#) shows a typical calculation for the XC9536 device.

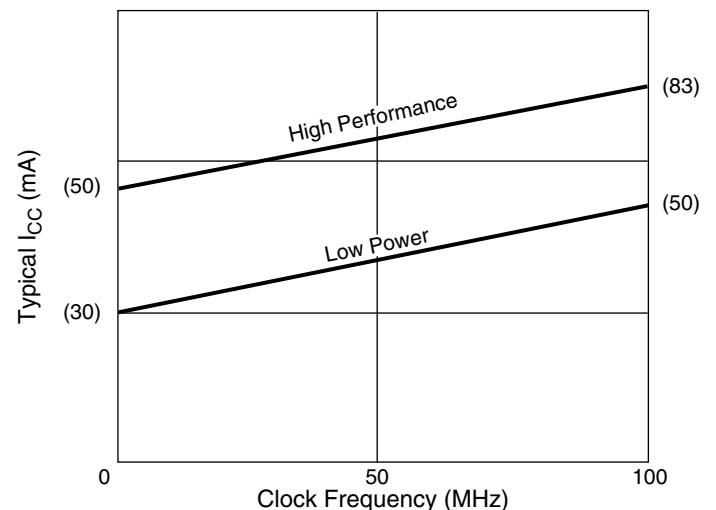

DS064_01_110101

Figure 1: Typical I_{CC} vs. Frequency for XC9536

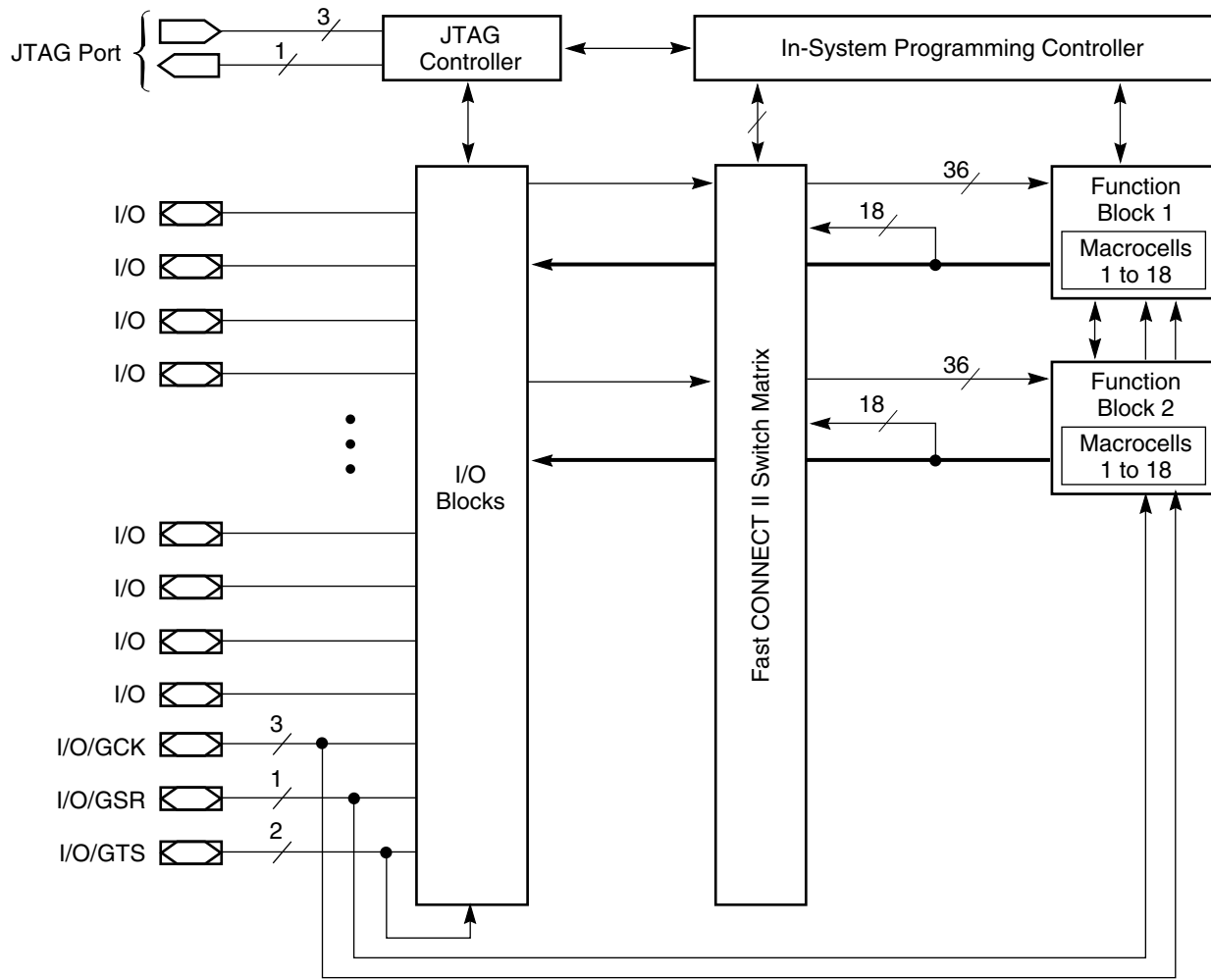

DS064_02_110101

Figure 2: XC9536 Architecture

Function block outputs (indicated by the bold line) drive the I/O blocks directly.

Absolute Maximum Ratings

Symbol	Description	Value	Units
V_{CC}	Supply voltage relative to GND	-0.5 to 7.0	V
V_{IN}	Input voltage relative to GND	-0.5 to $V_{CC} + 0.5$	V
V_{TS}	Voltage applied to 3-state output	-0.5 to $V_{CC} + 0.5$	V
T_{STG}	Storage temperature (ambient)	-65 to +150	°C
T_J	Junction temperature	+150	°C

Notes:

- Stresses beyond those listed under Absolute Maximum Ratings may cause permanent damage to the device. These are stress ratings only, and functional operation of the device at these or any other conditions beyond those listed under Operating Conditions is not implied. Exposure to Absolute Maximum Ratings conditions for extended periods of time may affect device reliability.

Recommended Operation Conditions

Symbol	Parameter		Min	Max	Units
V_{CCINT}	Supply voltage for internal logic and input buffers	Commercial $T_A = 0^\circ\text{C}$ to 70°C	4.75	5.25	V
		Industrial $T_A = -40^\circ\text{C}$ to $+85^\circ\text{C}$	4.5	5.5	
V_{CCIO}	Supply voltage for output drivers for 5V operation	Commercial $T_A = 0^\circ\text{C}$ to 70°C	4.75	5.25	V
		Industrial $T_A = -40^\circ\text{C}$ to $+85^\circ\text{C}$	4.5	5.5	
	Supply voltage for output drivers for 3.3V operation	3.0	3.6		
V_{IL}	Low-level input voltage		0	0.80	V
V_{IH}	High-level input voltage		2.0	$V_{CCINT} + 0.5$	V
V_O	Output voltage		0	V_{CCIO}	V

Quality and Reliability Characteristics

Symbol	Parameter	Min	Max	Units
T_{DR}	Data Retention	20	-	Years
N_{PE}	Program/Erase Cycles (Endurance)	10,000	-	Cycles

DC Characteristic Over Recommended Operating Conditions

Symbol	Parameter	Test Conditions	Min	Max	Units
V_{OH}	Output high voltage for 5V outputs	$I_{OH} = -4.0\text{ mA}$, $V_{CC} = \text{Min}$	2.4	-	V
	Output high voltage for 3.3V outputs	$I_{OH} = -3.2\text{ mA}$, $V_{CC} = \text{Min}$	2.4	-	V
V_{OL}	Output low voltage for 5V outputs	$I_{OL} = 24\text{ mA}$, $V_{CC} = \text{Min}$	-	0.5	V
	Output low voltage for 3.3V outputs	$I_{OL} = 10\text{ mA}$, $V_{CC} = \text{Min}$	-	0.4	V
I_{IL}	Input leakage current	$V_{CC} = \text{Max}$ $V_{IN} = \text{GND or } V_{CC}$	-	± 10	μA
I_{IH}	I/O high-Z leakage current	$V_{CC} = \text{Max}$ $V_{IN} = \text{GND or } V_{CC}$	-	± 10	μA
C_{IN}	I/O capacitance	$V_{IN} = \text{GND}$ $f = 1.0\text{ MHz}$	-	10	pF
I_{CC}	Operating supply current (low power mode, active)	$V_I = \text{GND}$, No load $f = 1.0\text{ MHz}$	30 (Typical)		mA

AC Characteristics

Symbol	Parameter	XC9536-5		XC9536-6		XC9536-7		XC9536-10		XC9536-15		Units
		Min	Max	Min	Max	Min	Max	Min	Max	Min	Max	
T_{PD}	I/O to output valid	-	5.0	-	6.0	-	7.5	-	10.0	-	15.0	ns
T_{SU}	I/O setup time before GCK	3.5	-	3.5	-	4.5	-	6.0	-	8.0	-	ns
T_H	I/O hold time after GCK	0	-	0	-	0	-	0	-	0	-	ns
T_{CO}	GCK to output valid	-	4.0	-	4.0	-	4.5	-	6.0	-	8.0	ns
$f_{CNT}^{(1)}$	16-bit counter frequency	100.0	-	100.0	-	125.0	-	111.1	-	95.2	-	MHz
$f_{SYSTEM}^{(2)}$	Multiple FB internal operating frequency	100.0	-	100.0	-	83.3	-	66.7	-	55.6	-	MHz
T_{PSU}	I/O setup time before p-term clock input	0.5	-	0.5	-	0.5	-	2.0	-	4.0	-	ns
T_{PH}	I/O hold time after p-term clock input	3.0	-	3.0	-	4.0	-	4.0	-	4.0	-	ns
T_{PCO}	P-term clock output valid	-	7.0	-	7.0	-	8.5	-	10.0	-	12.0	ns
T_{OE}	GTS to output valid	-	5.0	-	5.0	-	5.5	-	6.0	-	11.0	ns
T_{OD}	GTS to output disable	-	5.0	-	5.0	-	5.5	-	6.0	-	11.0	ns
T_{POE}	Product term OE to output enabled	-	9.0	-	9.0	-	9.5	-	10.0	-	14.0	ns
T_{POD}	Product term OE to output disabled	-	9.0	-	9.0	-	9.5	-	10.0	-	14.0	ns
T_{WLH}	GCK pulse width (High or Low)	4.0	-	4.0	-	4.0	-	4.5	-	5.5	-	ns
T_{APRPW}	Asynchronous preset/reset pulse width (High or Low)	7.0	-	7.0	-	7.0	-	7.5	-	8.0	-	ns

Notes:

- f_{CNT} is the fastest 16-bit counter frequency available, using the local feedback when applicable. f_{CNT} is also the Export Control Maximum flip-flop toggle rate, f_{TOG} .
- f_{SYSTEM} is the internal operating frequency for general purpose system designs spanning multiple FBs.

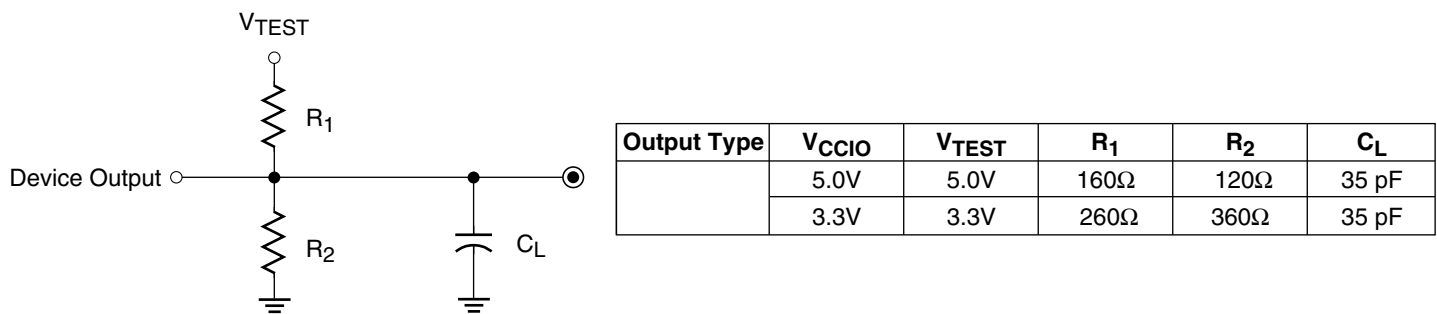

DS067_03_110101

Figure 3: AC Load Circuit

Internal Timing Parameters

Symbol	Parameter	XC9536-5		XC9536-6		XC9536-7		XC9536-10		XC9536-15		Units
		Min	Max	Min	Max	Min	Max	Min	Max	Min	Max	
Buffer Delays												
T_{IN}	Input buffer delay	-	1.5	-	1.5	-	2.5	-	3.5	-	4.5	ns
T_{GCK}	GCK buffer delay	-	1.5	-	1.5	-	1.5	-	2.5	-	3.0	ns
T_{GSR}	GSR buffer delay	-	4.0	-	4.0	-	4.5	-	6.0	-	7.5	ns
T_{GTS}	GTS buffer delay	-	5.0	-	5.0	-	5.5	-	6.0	-	11.0	ns
T_{OUT}	Output buffer delay	-	2.0	-	2.0	-	2.5	-	3.0	-	4.5	ns
T_{EN}	Output buffer enable/disable delay	-	0	-	0	-	0	-	0	-	0	ns
Product Term Control Delays												
T_{PTCK}	Product term clock delay	-	3.0	-	3.0	-	3.0	-	3.0	-	2.5	ns
T_{PTSR}	Product term set/reset delay	-	1.0	-	1.0	-	2.0	-	2.5	-	3.0	ns
T_{PTTS}	Product term 3-state delay	-	5.5	-	5.5	-	4.5	-	3.5	-	5.0	ns
Internal Register and Combinatorial Delays												
T_{PDI}	Combinatorial logic propagation delay	-	0.5	-	0.5	-	0.5	-	1.0	-	3.0	ns
T_{SUI}	Register setup time	2.5	-	2.5	-	1.5	-	2.5	-	3.5	-	ns
T_{HI}	Register hold time	1.0	-	1.0	-	3.0	-	3.5	-	4.5	-	ns
T_{COI}	Register clock to output valid time	-	0.5	-	0.5	-	0.5	-	0.5	-	0.5	ns
T_{AOI}	Register async. S/R to output delay	-	6.0	-	6.0	-	6.5	-	7.0	-	8.0	ns
T_{RAI}	Register async. S/R recover before clock	5.0	-	5.0	-	7.5	-	10.0	-	10.0	-	ns
T_{LOGI}	Internal logic delay	-	1.0	-	1.0	-	2.0	-	2.5	-	3.0	ns
T_{LOGILP}	Internal low power logic delay	-	9.0	-	9.0	-	10.0	-	11.0	-	11.5	ns
Feedback Delays												
T_F	FastCONNECT feedback delay	-	6.0	-	6.0	-	8.0	-	9.5	-	11.0	ns
Time Adders												
$T_{PTA}^{(1)}$	Incremental product term allocator delay	-	0.8	-	0.8	-	1.0	-	1.0	-	1.0	ns
T_{SLEW}	Slew-rate limited delay	-	3.5	-	3.5	-	4.0	-	4.5	-	5.0	ns

Notes:

- T_{PTA} is multiplied by the span of the function as defined in the XC9500 family data sheet.

XC9536 I/O Pins

Function Block	Macroce ll	PC44	VQ44	CS48	BScan Order
1	1	2	40	D6	105
1	2	3	41	C7	102
1	3	5 ^[1]	43 ^[1]	B7 ^[1]	99
1	4	4	42	C6	96
1	5	6 ^[1]	44 ^[1]	B6 ^[1]	93
1	6	8	2	A6	90
1	7	7 ^[1]	1 ^[1]	A7 ^[1]	87
1	8	9	3	C5	84
1	9	11	5	B5	81
1	10	12	6	A4	78
1	11	13	7	B4	75
1	12	14	8	A3	72
1	13	18	12	B2	69
1	14	19	13	B1	66
1	15	20	14	C2	63
1	16	22	16	C3	60
1	17	24	18	D2	57
1	18	–	–	–	54

Function Block	Macroce ll	PC44	VQ44	CS48	BScan Order
2	1	1	39	D7	51
2	2	44	38	E5	48
2	3	42 ^[1]	36 ^[1]	E6 ^[1]	45
2	4	43	37	E7	42
2	5	40 ^[1]	34 ^[1]	F6 ^[1]	39
2	6	39 ^[1]	33 ^[1]	G7 ^[1]	36
2	7	38	32	G6	33
2	8	37	31	F5	30
2	9	36	30	G5	27
2	10	35	29	F4	24
2	11	34	28	G4	21
2	12	33	27	E3	18
2	13	29	23	F2	15
2	14	28	22	G1	12
2	15	27	21	F1	9
2	16	26	20	E2	6
2	17	25	19	E1	3
2	18	–	–	–	0

Notes :

1. Global control pin.

XC9536 Global, JTAG and Power Pins

Pin Type	PC44	VQ44	CS48
I/O/GCK1	5	43	B7
I/O/GCK2	6	44	B6
I/O/GCK3	7	1	A7
I/O/GTS1	42	36	E6
I/O/GTS2	40	34	F6
I/O/GSR	39	33	G7
TCK	17	11	A1
TDI	15	9	B3
TDO	30	24	G2
TMS	16	10	A2
V _{CCINT} 5V	21, 41	15, 35	C1, F7
V _{CCIO} 3.3V/5V	32	26	G3
GND	23, 10, 31	17, 4, 25	A5, D1, F3
No Connects	—	—	C4, D3, D4, E4

Device Part Marking and Ordering Combination Information

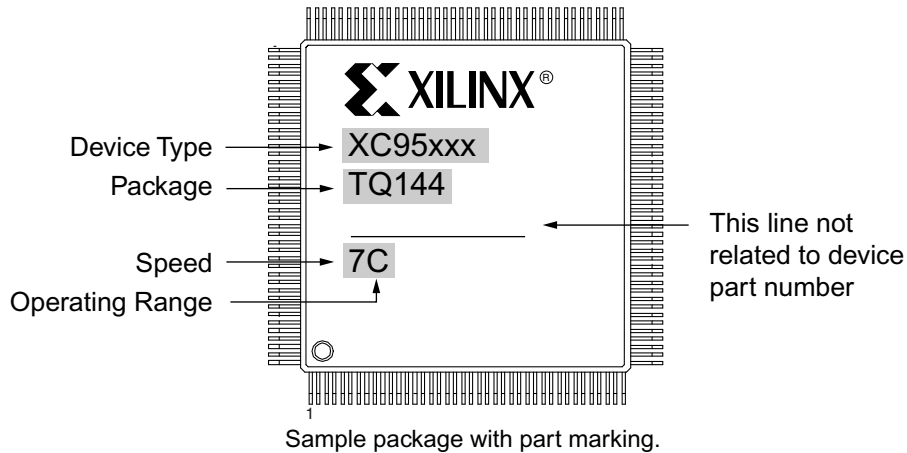

Notes:

1. Due to the small size of chip scale packages, part marking on these packages does not follow the above sample and the complete part number cannot be included in the marking. Part marking on chip scale packages by line:
 - Line 1 = X (Xilinx logo), then truncated part number (no XC), i.e., 95xxx.
 - Line 2 = Not related to device part number.
 - Line 3 = Not related to device part number.
 - Line 4 = Package code, speed, operating temperature, three digits not related to device part number. Package code: C1 = CS48.

Device Ordering and Part Marking Number	Speed (pin-to-pin delay)	Pkg. Symbol	No. of Pins	Package Type	Operating Range ⁽¹⁾
XC9536-5PC44C	5 ns	PC44	44-pin	Plastic Lead Chip Carrier (PLCC)	C
XC9536-5PCG44C	5 ns	PCG44	44-pin	Plastic Lead Chip Carrier (PLCC); Pb-Free	C
XC9536-5VQ44C	5 ns	VQ44	44-pin	Very Thin Quad Flat Pack (VQFP)	C
XC9536-5VQG44C	5 ns	VQG44	44-pin	Very Thin Quad Flat Pack (VQFP); Pb-Free	C
XC9536-5CS48C	5 ns	CS48	48-ball	Chip Scale Package (CSP)	C
XC9536-5CSG48C	5 ns	CSG48	48-ball	Chip Scale Package (CSP); Pb-Free	C
XC9536-6PC44C	6 ns	PC44	44-pin	Plastic Lead Chip Carrier (PLCC)	C
XC9536-6PCG44C	6 ns	PCG44	44-pin	Plastic Lead Chip Carrier (PLCC); Pb-Free	C
XC9536-6VQ44C	6 ns	VQ44	44-pin	Very Thin Quad Flat Pack (VQFP)	C
XC9536-6VQG44C	6 ns	VQG44	44-pin	Very Thin Quad Flat Pack (VQFP); Pb-Free	C
XC9536-7PC44C	7.5 ns	PC44	44-pin	Plastic Lead Chip Carrier (PLCC)	C
XC9536-7PCG44C	7.5 ns	PCG44	44-pin	Plastic Lead Chip Carrier (PLCC); Pb-Free	C
XC9536-7VQ44C	7.5 ns	VQ44	44-pin	Very Thin Quad Flat Pack (VQFP)	C
XC9536-7VQG44C	7.5 ns	VQG44	44-pin	Very Thin Quad Flat Pack (VQFP); Pb-Free	C
XC9536-7CS48C	7.5 ns	CS48	48-ball	Chip Scale Package (CSP)	C
XC9536-7CSG48C	7.5 ns	CSG48	48-ball	Chip Scale Package (CSP); Pb-Free	C
XC9536-7PC44I	7.5 ns	PC44	44-pin	Plastic Lead Chip Carrier (PLCC)	I
XC9536-7PCG44I	7.5 ns	PCG44	44-pin	Plastic Lead Chip Carrier (PLCC); Pb-Free	I
XC9536-7VQ44I	7.5 ns	VQ44	44-pin	Very Thin Quad Flat Pack (VQFP)	I
XC9536-7VQG44I	7.5 ns	VQG44	44-pin	Very Thin Quad Flat Pack (VQFP); Pb-Free	I
XC9536-10PC44C	10 ns	PC44	44-pin	Plastic Lead Chip Carrier (PLCC)	C
XC9536-10PCG44C	10 ns	PCG44	44-pin	Plastic Lead Chip Carrier (PLCC); Pb-Free	C
XC9536-10VQ44C	10 ns	VQ44	44-pin	Very Thin Quad Flat Pack (VQFP)	C

Device Ordering and Part Marking Number	Speed (pin-to-pin delay)	Pkg. Symbol	No. of Pins	Package Type	Operating Range ⁽¹⁾
XC9536-10VQG44C	10 ns	VQG44	44-pin	Very Thin Quad Flat Pack (VQFP); Pb-Free	C
XC9536-10CS48C	10 ns	CS48	48-ball	Chip Scale Package (CSP)	C
XC9536-10CSG48C	10 ns	CSG48	48-ball	Chip Scale Package (CSP); Pb-Free	C
XC9536-10PC44I	10 ns	PC44	44-pin	Plastic Lead Chip Carrier (PLCC)	I
XC9536-10PCG44I	10 ns	PCG44	44-pin	Plastic Lead Chip Carrier (PLCC); Pb-Free	I
XC9536-10VQ44I	10 ns	VQ44	44-pin	Very Thin Quad Flat Pack (VQFP)	I
XC9536-10VQG44I	10 ns	VQG44	44-pin	Very Thin Quad Flat Pack (VQFP); Pb-Free	I
XC9536-10CS48I	10 ns	CS48	48-ball	Chip Scale Package (CSP)	I
XC9536-10CSG48I	10 ns	CSG48	48-ball	Chip Scale Package (CSP); Pb-Free	I
XC9536-15PC44C	15 ns	PC44	44-pin	Plastic Lead Chip Carrier (PLCC)	C
XC9536-15PCG44C	15 ns	PCG44	44-pin	Plastic Lead Chip Carrier (PLCC); Pb-Free	C
XC9536-15VQ44C	15 ns	VQ44	44-pin	Very Thin Quad Flat Pack (VQFP)	C
XC9536-15VQG44C	15 ns	VQG44	44-pin	Very Thin Quad Flat Pack (VQFP); Pb-Free	C
XC9536-15PC44I	15 ns	PC44	44-pin	Plastic Lead Chip Carrier (PLCC)	I
XC9536-15PCG44I	15 ns	PCG44	44-pin	Plastic Lead Chip Carrier (PLCC); Pb-Free	I
XC9536-15VQ44I	15 ns	VQ44	44-pin	Very Thin Quad Flat Pack (VQFP)	I
XC9536-15VQG44I	15 ns	VQG44	44-pin	Very Thin Quad Flat Pack (VQFP); Pb-Free	I

Notes:

1. C = Commercial: T_A = 0° to +70°C; I = Industrial: T_A = -40° to +85°C.

Warranty Disclaimer

THESE PRODUCTS ARE SUBJECT TO THE TERMS OF THE XILINX LIMITED WARRANTY WHICH CAN BE VIEWED AT <http://www.xilinx.com/warranty.htm>. THIS LIMITED WARRANTY DOES NOT EXTEND TO ANY USE OF THE PRODUCTS IN AN APPLICATION OR ENVIRONMENT THAT IS NOT WITHIN THE SPECIFICATIONS STATED ON THE THEN-CURRENT XILINX DATA SHEET FOR THE PRODUCTS. PRODUCTS ARE NOT DESIGNED TO BE FAIL-SAFE AND ARE NOT WARRANTED FOR USE IN APPLICATIONS THAT POSE A RISK OF PHYSICAL HARM OR LOSS OF LIFE. USE OF PRODUCTS IN SUCH APPLICATIONS IS FULLY AT THE RISK OF CUSTOMER SUBJECT TO APPLICABLE LAWS AND REGULATIONS.

Revision History

The following table shows the revision history for this document.

Date	Version	Revision
12/04/1998	5.0	Revised data sheet to remove PCI compliancy statement and remove T _{LF}
06/18/2003	6.0	Updated format.
08/21/2003	6.1	Updated Package Device Marking Pin 1 orientation.
04/15/2005	6.2	Added Asynchronous Preset Reset Pulse Width Specification (T _{APRPW})
04/03/2006	6.3	Added Warranty Disclaimer. Added Pb-Free package ordering information.
05/17/2013	7.0	The products listed in this data sheet are obsolete. See XCN11010 for further information.

Компания «Life Electronics» занимается поставками электронных компонентов импортного и отечественного производства от производителей и со складов крупных дистрибьюторов Европы, Америки и Азии.

С конца 2013 года компания активно расширяет линейку поставок компонентов по направлению коаксиальный кабель, кварцевые генераторы и конденсаторы (керамические, пленочные, электролитические), за счёт заключения дистрибьюторских договоров

Мы предлагаем:

- Конкурентоспособные цены и скидки постоянным клиентам.
- Специальные условия для постоянных клиентов.
- Подбор аналогов.
- Поставку компонентов в любых объемах, удовлетворяющих вашим потребностям.
- Приемлемые сроки поставки, возможна ускоренная поставка.
- Доставку товара в любую точку России и стран СНГ.
- Комплексную поставку.
- Работу по проектам и поставку образцов.
- Формирование склада под заказчика.
- Сертификаты соответствия на поставляемую продукцию (по желанию клиента).
- Тестирование поставляемой продукции.
- Поставку компонентов, требующих военную и космическую приемку.
- Входной контроль качества.
- Наличие сертификата ISO.

В составе нашей компании организован Конструкторский отдел, призванный помогать разработчикам, и инженерам.

Конструкторский отдел помогает осуществить:

- Регистрацию проекта у производителя компонентов.
- Техническую поддержку проекта.
- Защиту от снятия компонента с производства.
- Оценку стоимости проекта по компонентам.
- Изготовление тестовой платы монтаж и пусконаладочные работы.



Тел: +7 (812) 336 43 04 (многоканальный)
Email: org@lifeelectronics.ru