

# PLASTIC PACKAGE PURE SILICON™ CLOCK OSCILLATOR

ASFLM



Life Size



5.0 x 3.2 x 0.85 mm

ASFLM

RoHS/RoHS II Compliant

## FEATURES:

- Pure Silicon™ Clock Oscillator
- MEMS Technology by Discera
- Low Power Consumption <10mA
- Low Stand by Current <1uA
- Exceptional Stability Over Temp. at 40 to +85°C
- Available over Extended Temp Range
- Low Cost-Compact QFN Plastic Packaging
- Compact Package design

## APPLICATIONS:

- CCD Clock for VTR Camera
- Equipment Connected to PCs
- Low Profile Equipment
- Lower Cost Crystal Oscillator Replacement
- Computers and Peripherals
- Portable Electronics (MP3 Players, Games)
- Consumer Electronics such as TV's, DVR's, etc.
- Vibrant, Shock-Prone & Humid Environments for Industrial Equipment
- Demanding Military & Automotive Electronics



## STANDARD SPECIFICATIONS:

Parameters		Minimum	Typical	Maximum	Units	Notes
Frequency Range:		1.0	-----	150	MHz	
Operating Temperature:		0	-----	+70	°C	See options
Storage Temperature:		-55	-----	+150	°C	
Overall Frequency Stability*:		-100	-----	+100	ppm	See options
Supply Voltage (Vdd):		+1.8 ~ +3.3			V	See options
Supply Current (no load):	1.0 to 39.9999MHz	-----	3	10	mA	No load RL=∞ T=25°C
	40.0 to 79.9999MHz	-----	4	10		
	80.0 to 124.9999MHz	-----	5	10		
	125.0 to 150MHz	-----	6	10		
Output Voltage:	V <sub>OH</sub>	0.8*V <sub>dd</sub>	-----	-----	V	15pF
	V <sub>OL</sub>	-----	-----	0.2*V <sub>dd</sub>		
Rise Time:	T <sub>r</sub>	-----	1.3	2.0	ns	15pF; T=25°C 20%/80%*VDD
Fall Time:	T <sub>f</sub>	-----	1.3	2.0		
Output Load:		15pF max / 10kΩ min.			pF	See options
Symmetry:		45	-----	55	%	@1/2V <sub>dd</sub>
Startup Time:		-----	1.5	3.0	ms	
Disable Time:		-----	20	100	ns	
Disable Stand-by Current:		-----	-----	1	uA	
Tri-state Function (Stand-by) :		"1" (VIH≥0.75*V <sub>dd</sub> ) or Open: Oscillation "0" (VIH<0.25*V <sub>dd</sub> ) : Hi Z			V	
Cycle to cycle jitter:		-----	95	-----	ps	F=100MHz
Aging:		-5.0	-----	+5.0	ppm	First year

## Absolute Maximum Ratings

Item	Minimum	Maximum	Unit	Condition
Supply Voltage	-0.3	+4.0	V	
Input Voltage	-0.3	V <sub>dd</sub> +0.3	V	
Junction Temp.	-----	+150	°C	
Soldering Temp.	-----	+260	°C	40sec max
ESD			V	
HBM		2,000		
MM		200		
CDM		500		

ABRACON IS  
ISO 9001: 2008  
CERTIFIED



2 Faraday, Suite# B | Irvine | CA 92618 Revised: 04.30.15  
Ph. 949.546.8000 | Fax. 949.546.8001  
Visit [www.abracon.com](http://www.abracon.com) for Terms and Conditions of Sale



## PART NUMBER FOR PROGRAMMED ORDER S

Programmed Orders (Quantity > 1,000pcs)

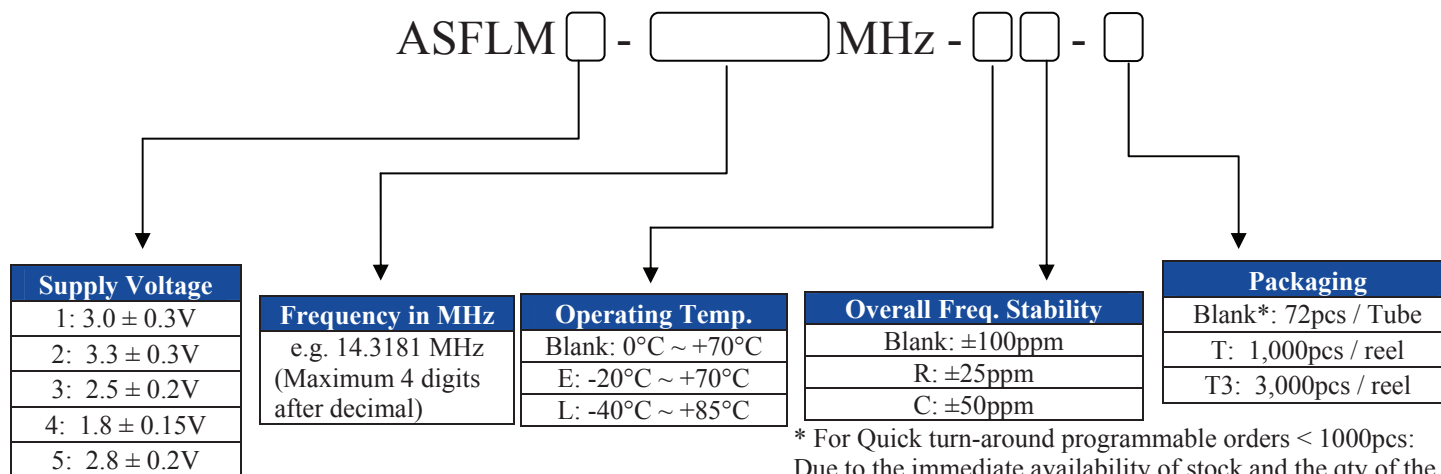

\* For Quick turn-around programmable orders < 1000pcs: Due to the immediate availability of stock and the qty of the order, the parts may be delivered as BULK: Cut Tape, Loose parts in Antistatic Bag or in Tube(s). The MOQ per the series will still apply for Tube packaging.

## Un-Programmed Orders (Quantity < 1,000pcs)

Blank un-programmed oscillators and our low cost portable programmer are available for quick turn engineering requirements. Please call ABRACON or visit MEMSpeed Pro site <http://www.abracon.com/memspeedpro/memspeedpro.html> for more information.

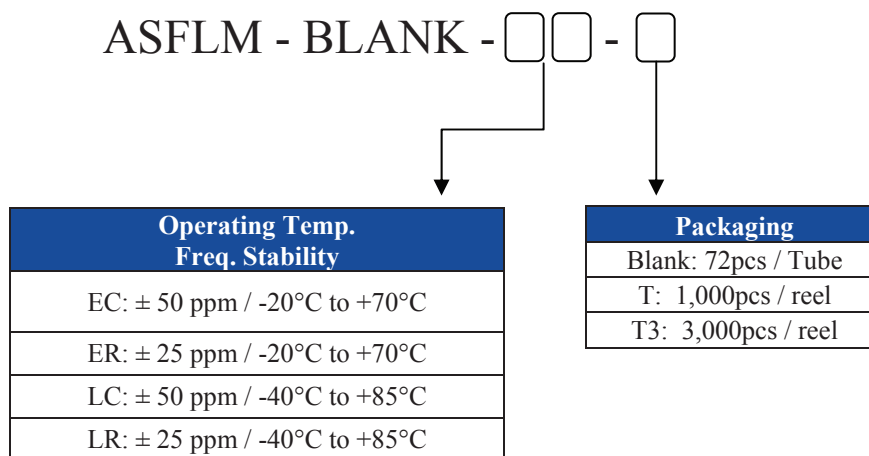

# PLASTIC PACKAGE PURE SILICON™ CLOCK OSCILLATOR

ASFLM



Life Size



5.0 x 3.2 x 0.85 mm

ASFLM

**Pb** | RoHS/RoHS II Compliant

## OUTLINE DRAWING:

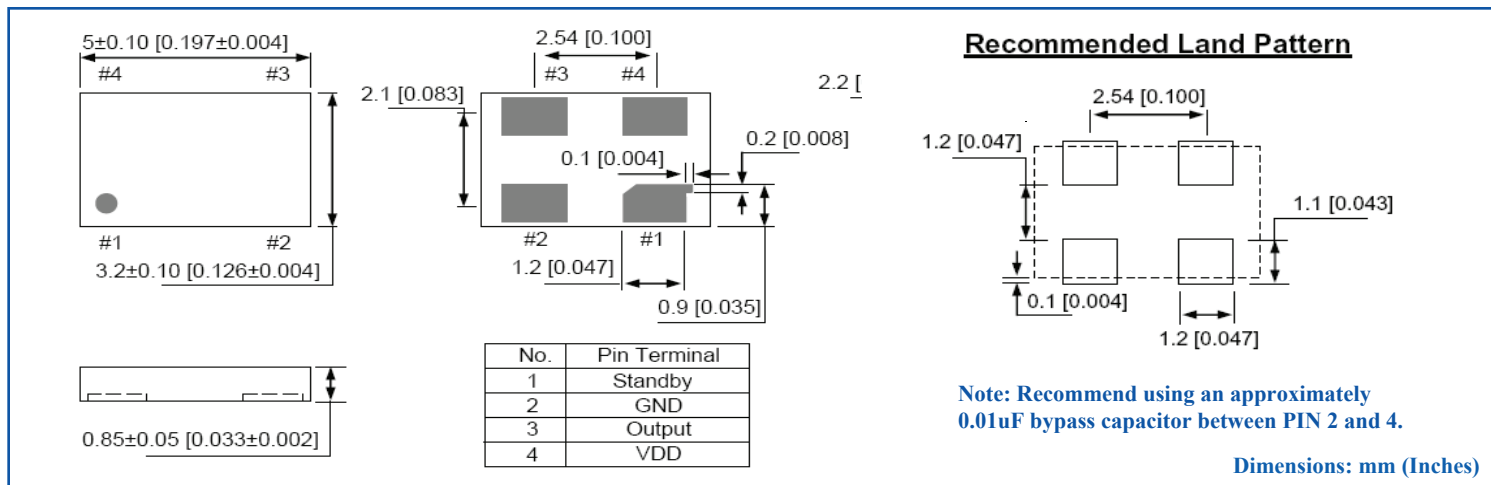

## TAPE & REEL:

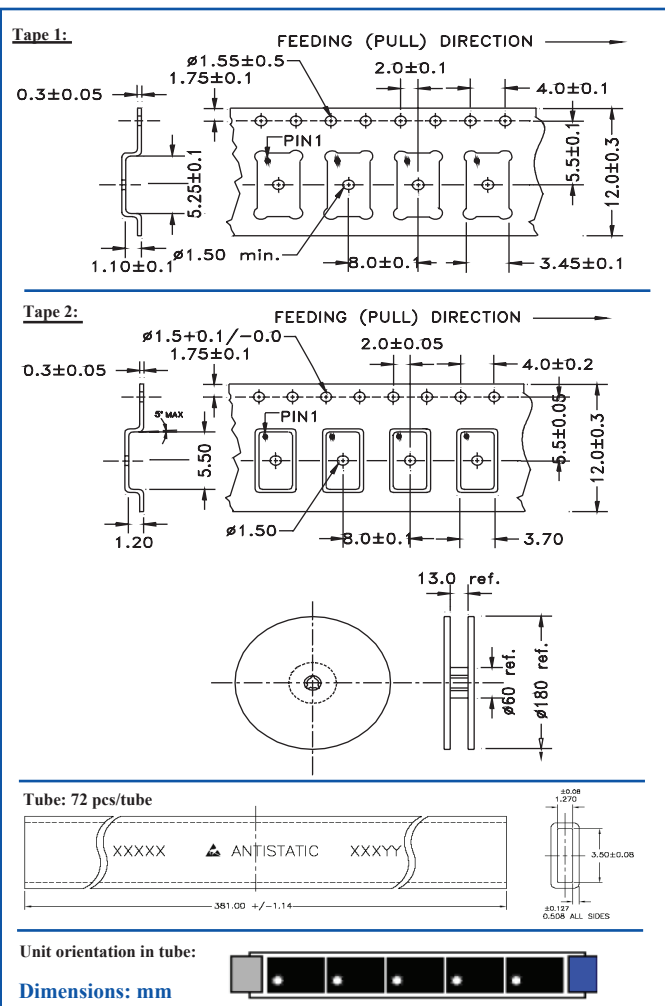

## REFLOW PROFILE:

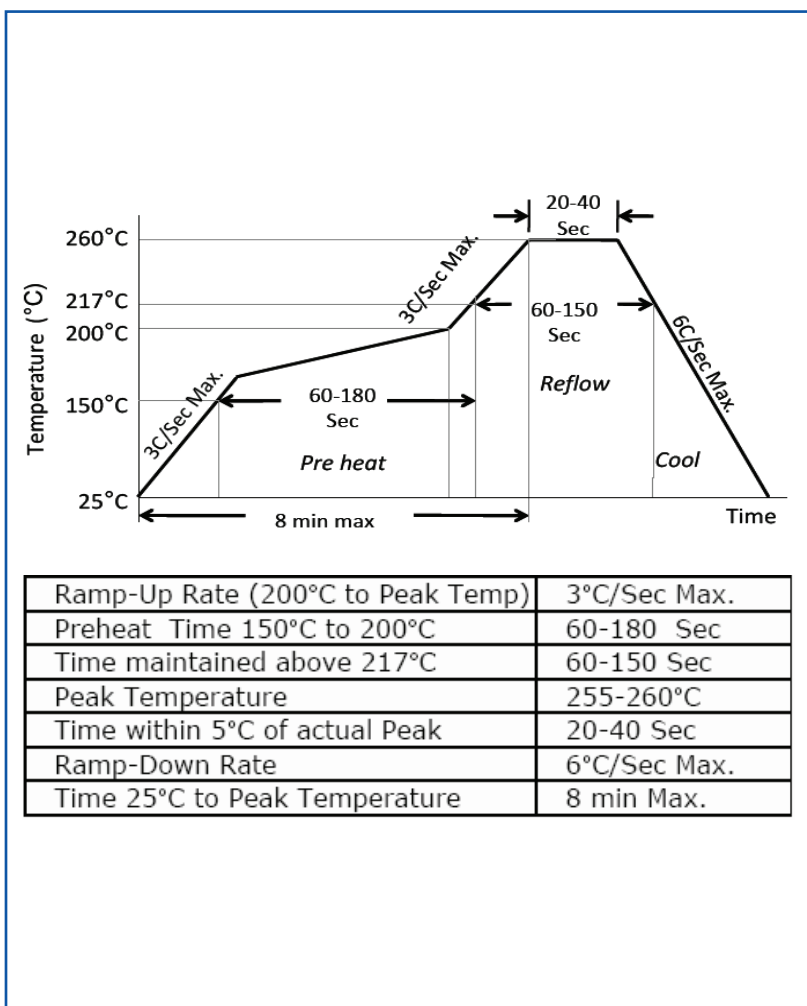

Need a test socket for the ASFLM Series? To view compatible **PRECISION TEST & BURN-IN SOCKETS** for these parts, [click here](#). P/N: **AXS-5032-04-07**

**ATTENTION:** Abracon Corporation's products are COTS – Commercial-Off-The-Shelf products; suitable for Commercial, Industrial and, where designated, Automotive Applications. Abracon's products are not specifically designed for Military, Aviation, Aerospace, Life-dependant Medical applications or any application requiring high reliability where component failure could result in loss of life and/or property. For applications requiring high reliability and/or presenting an extreme operating environment, written consent and authorization from Abracon Corporation is required. Please contact Abracon Corporation for more information.

ABRACON IS  
ISO 9001: 2008  
CERTIFIED



2 Faraday, Suite# B | Irvine | CA 92618 **Revised: 04.30.15**  
Ph. 949.546.8000 | Fax. 949.546.8001  
Visit [www.abracon.com](http://www.abracon.com) for Terms and Conditions of Sale

Компания «Life Electronics» занимается поставками электронных компонентов импортного и отечественного производства от производителей и со складов крупных дистрибьюторов Европы, Америки и Азии.

С конца 2013 года компания активно расширяет линейку поставок компонентов по направлению коаксиальный кабель, кварцевые генераторы и конденсаторы (керамические, пленочные, электролитические), за счёт заключения дистрибьюторских договоров

Мы предлагаем:

- Конкурентоспособные цены и скидки постоянным клиентам.
- Специальные условия для постоянных клиентов.
- Подбор аналогов.
- Поставку компонентов в любых объемах, удовлетворяющих вашим потребностям.
- Приемлемые сроки поставки, возможна ускоренная поставка.
- Доставку товара в любую точку России и стран СНГ.
- Комплексную поставку.
- Работу по проектам и поставку образцов.
- Формирование склада под заказчика.
- Сертификаты соответствия на поставляемую продукцию (по желанию клиента).
- Тестирование поставляемой продукции.
- Поставку компонентов, требующих военную и космическую приемку.
- Входной контроль качества.
- Наличие сертификата ISO.

В составе нашей компании организован Конструкторский отдел, призванный помогать разработчикам, и инженерам.

Конструкторский отдел помогает осуществить:

- Регистрацию проекта у производителя компонентов.
- Техническую поддержку проекта.
- Защиту от снятия компонента с производства.
- Оценку стоимости проекта по компонентам.
- Изготовление тестовой платы монтаж и пусконаладочные работы.



Тел: +7 (812) 336 43 04 (многоканальный)

Email: [org@lifeelectronics.ru](mailto:org@lifeelectronics.ru)