



**Eval Kit Manual**

# **AS5170**

## **Adapter Board**

**AS5170-SO\_EK\_AB**

## Table of Contents

1	Introduction .....	3
1.1	Kit Content .....	3
2	Board description .....	4
2.1	Mounting the AS5170 adapter board .....	5
3	AS5170 adapter board and pinout .....	6
4	Operation case .....	7
4.1	Connection to AS5xxx-EK-USB-PB UART Programmer .....	7
5	AS5170-SO_EK_AB Hardware.....	8
5.1	AS5170-SO_EK_AB schematics .....	8
5.2	AS5170-SO_EK_AB PCB layout .....	9
6	Ordering & Contact Information .....	10
7	Copyrights & Disclaimer.....	11

## Revision History

Revision	Date	Owner	Description
1.0	26.06.2016	mzie	Initial version

## 1 Introduction

The AS5170 adapter board is a small PCB allowing simple and quick testing or evaluation of the AS5170 magnetic position sensor without the need to design and manufacture an own PCB.

### 1.1 Kit Content

Figure 1: Kit content

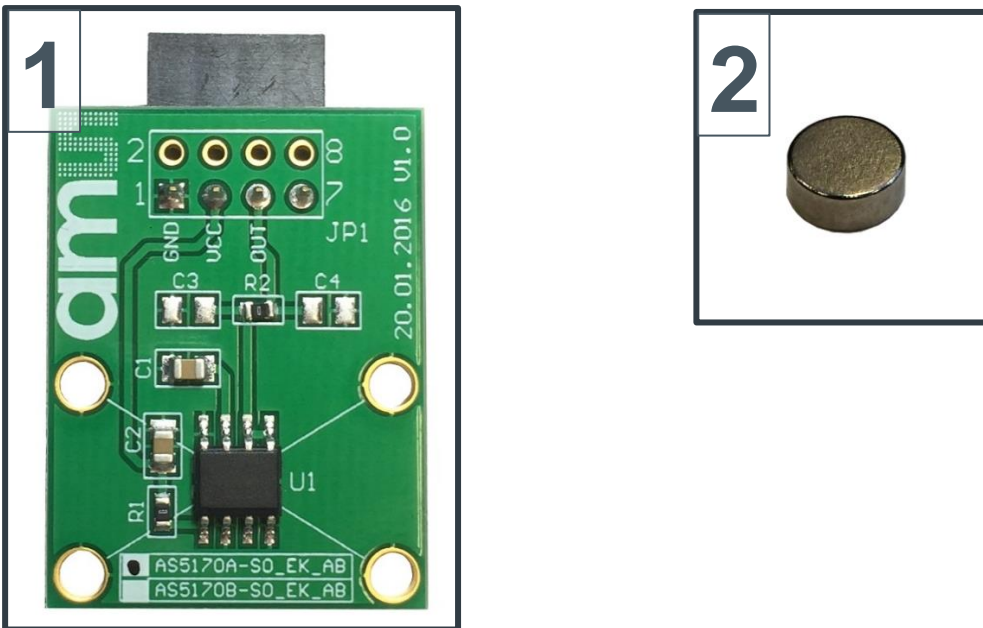

Pos.	Item	Comment
1	AS5170-SO_EK_AB	Adapter board
2	AS5000-MD8H-1	Diametric Magnet, D8x2.5mm, NdFeB, Bomatec AG

## 2 Board description

The PCB can be connected to an external microcontroller or to the AS5xxx-EK-USB-PB UART Programmer which can be used in combination with the AS5170 Software GUI provided by ams AG.

JP1 is populated with a 1x4 female pin header it is required for the power supply (VCC and GND) and output (OUT). This connector directly fits to the UART Programmer.

All necessary external components C1 (VDD3V3-GND) and C2 (VDD-GND) are already populated to the PCB.

Figure 2: AS5170 adapter board

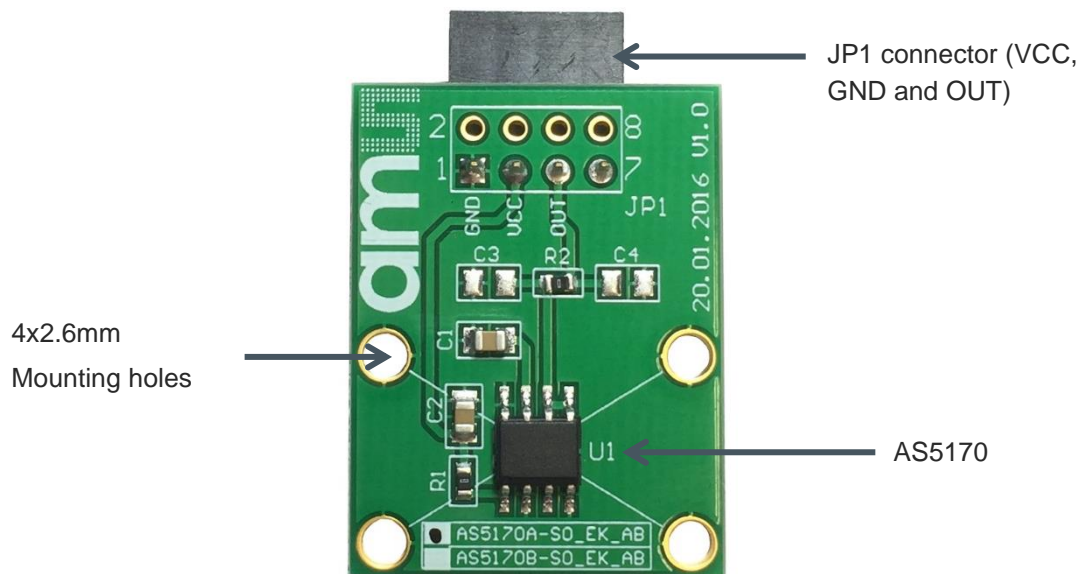

## 2.1 Mounting the AS5170 adapter board

Figure 3: Mounting and dimensions

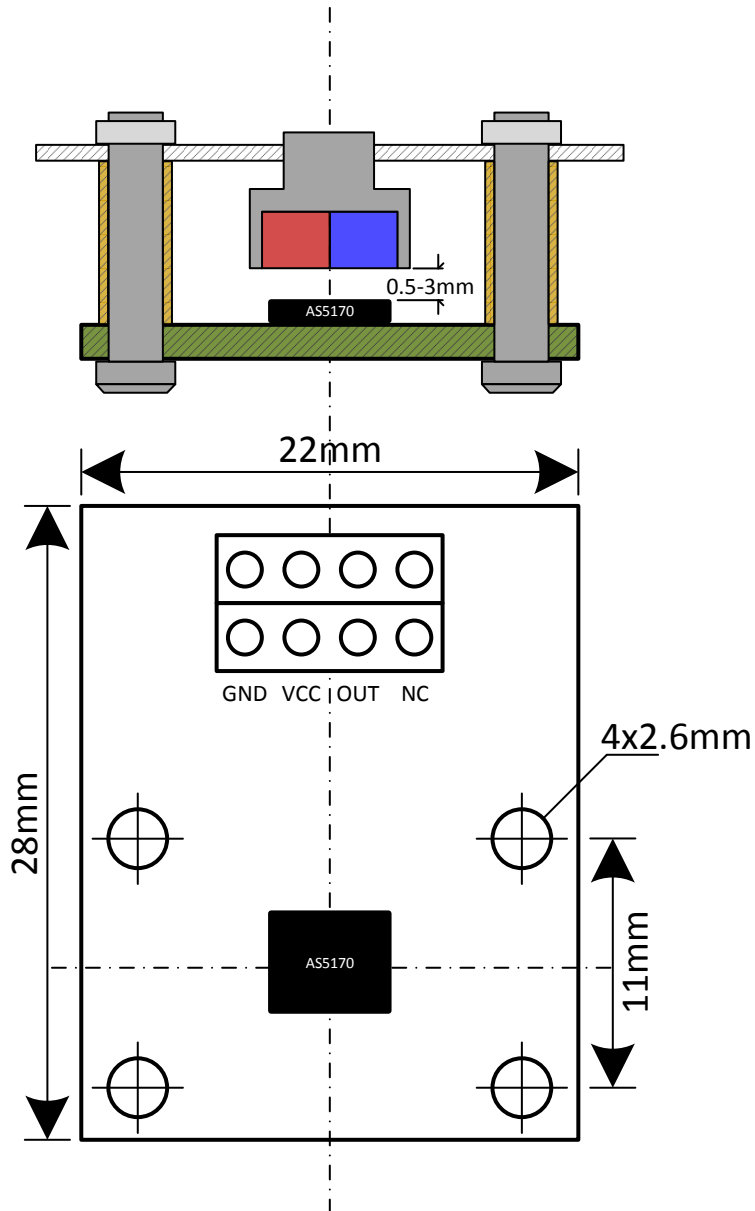

A 8x2.5mm diametric magnet must be placed over or under the AS5170 sensor, and should be centered in the middle of the package with a tolerance of 0.5mm. The airgap between the magnet surface and the package should be maintained in the range 0.5mm to 3mm. The magnet holder must not be ferromagnetic. Materials as brass, copper, aluminum, stainless steel are the best choices to make this part.

### 3 AS5170 adapter board and pinout

Figure 4: AS5170 adapter board and sensor pinout

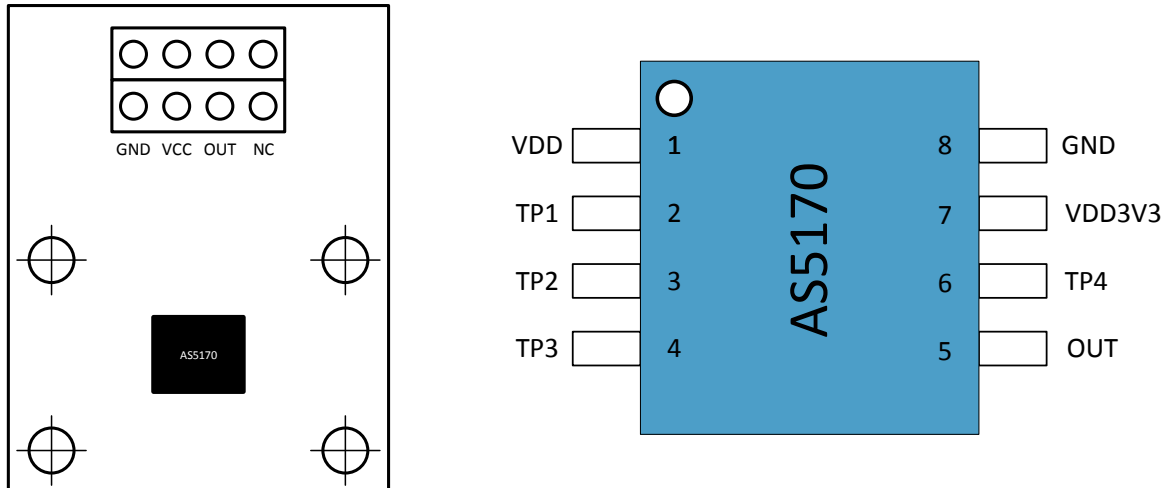

Pin# Board	Pin# AS5170	Symbol board	Type	Description
JP1 - 1	8	GND	Power supply	Ground
JP1 - 2		NC		
JP1 - 3	1	VCC	Power supply	Positive supply voltage
JP1 - 4		NC		
JP1 - 5	5	OUT	Analog or digital output	Output (UART in communication mode)
JP1 - 6		NC		
JP1 - 7		NC		
JP1 - 8		NC		

## 4 Operation case

### 4.1 Connection to AS5xxx-EK-USB-PB UART Programmer

The AS5170 adapter board can be directly connected to the AS5xxx-EK-USB-PB UART Programmer using only 3 lines (VDD, GND and OUT). The voltage supply is coming directly from the programmer which can either be supplied directly via 5V from USB or externally. The UART communication is taking place over the OUT pin. The necessary pull-up resistor is already in place on the programmer PCB. For AS5170 always use the BOT (bottom) connector of the programmer as shown in figure below.

**Figure 5: One device SPI mode, unidirectional – 3 wire**

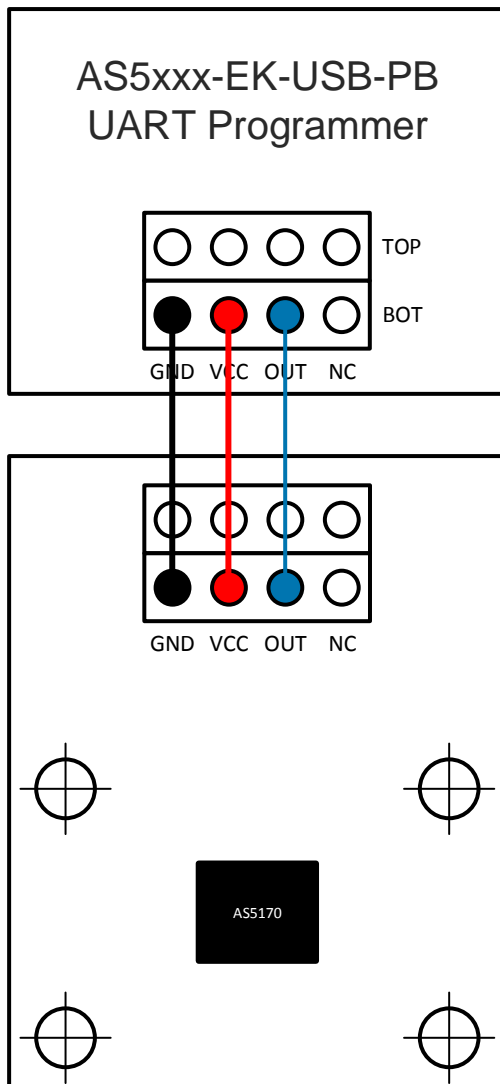

## 5 AS5170-SO\_EK\_AB Hardware

### 5.1 AS5170-SO\_EK\_AB schematics

The PCB schematic is shown in Figure 6: Schematics.

**Figure 6: Schematics**

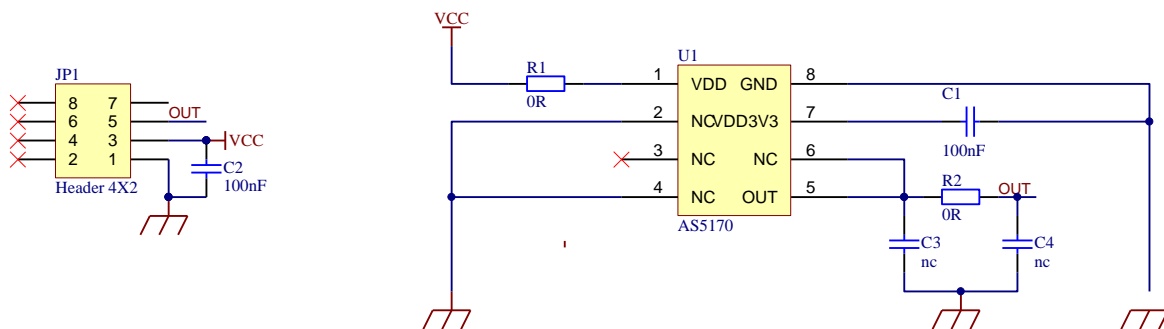



## 5.2 AS5170-SO\_EK\_AB PCB layout

The PCB layout is shown in Figure 7: Top Layer and Figure 8: Bottom Layer.

Figure 7: Top Layer

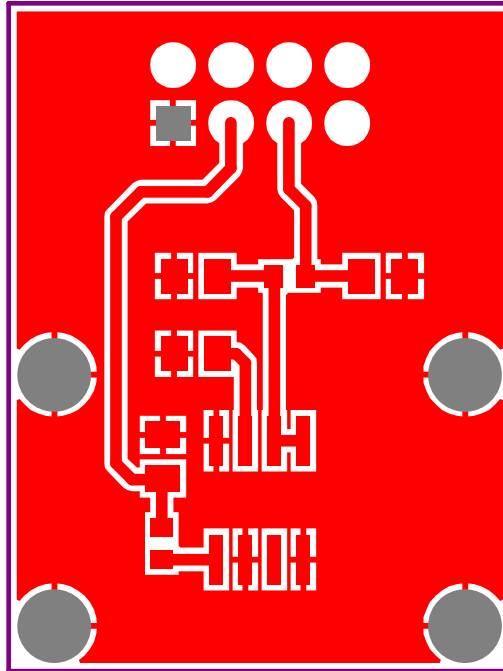
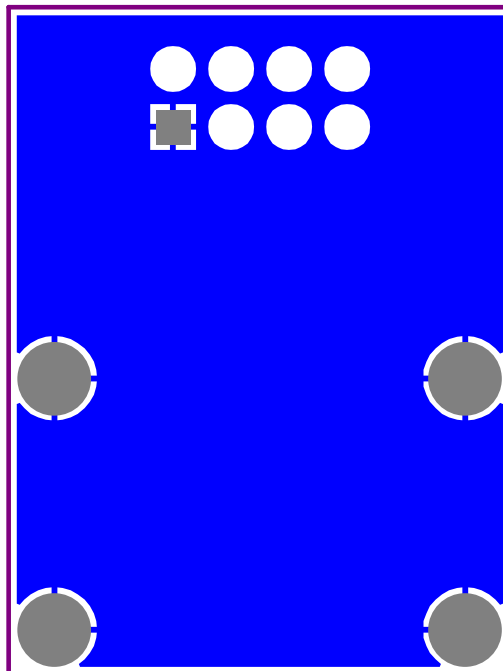

Figure 8: Bottom Layer



## 6 Ordering & Contact Information

Ordering Code	Description
AS5170-SO_EK_AB	AS5170 Eval Kit Adapter Board

**Buy our products or get free samples online at:**

[www.ams.com/ICdirect](http://www.ams.com/ICdirect)

**Technical Support is available at:**

[www.ams.com/Technical-Support](http://www.ams.com/Technical-Support)

**Provide feedback about this document at:**

[www.ams.com/Document-Feedback](http://www.ams.com/Document-Feedback)

**For further information and requests, e-mail us at:**

[ams\\_sales@ams.com](mailto:ams_sales@ams.com)

**For sales offices, distributors and representatives, please visit:**

[www.ams.com/contact](http://www.ams.com/contact)

### Headquarters

ams AG

Tobelbaderstrasse 30

8141 Premstaetten

Austria, Europe

Tel: +43 (0) 3136 500 0

Website: [www.ams.com](http://www.ams.com)

## 7 Copyrights & Disclaimer

Copyright ams AG, Tobelbader Strasse 30, 8141 Premstaetten, Austria-Europe. Trademarks Registered. All rights reserved. The material herein may not be reproduced, adapted, merged, translated, stored, or used without the prior written consent of the copyright owner.

Demo Kits, Evaluation Kits and Reference Designs are provided to recipient on an “as is” basis for demonstration and evaluation purposes only and are not considered to be finished end-products intended and fit for general consumer use, commercial applications and applications with special requirements such as but not limited to medical equipment or automotive applications. Demo Kits, Evaluation Kits and Reference Designs have not been tested for compliance with electromagnetic compatibility (EMC) standards and directives, unless otherwise specified. Demo Kits, Evaluation Kits and Reference Designs shall be used by qualified personnel only.

ams AG reserves the right to change functionality and price of Demo Kits, Evaluation Kits and Reference Designs at any time and without notice.

Any express or implied warranties, including, but not limited to the implied warranties of merchantability and fitness for a particular purpose are disclaimed. Any claims and demands and any direct, indirect, incidental, special, exemplary or consequential damages arising from the inadequacy of the provided Demo Kits, Evaluation Kits and Reference Designs or incurred losses of any kind (e.g. loss of use, data or profits or business interruption however caused) as a consequence of their use are excluded.

ams AG shall not be liable to recipient or any third party for any damages, including but not limited to personal injury, property damage, loss of profits, loss of use, interruption of business or indirect, special, incidental or consequential damages, of any kind, in connection with or arising out of the furnishing, performance or use of the technical data herein. No obligation or liability to recipient or any third party shall arise or flow out of ams AG rendering of technical or other services.

Компания «Life Electronics» занимается поставками электронных компонентов импортного и отечественного производства от производителей и со складов крупных дистрибьюторов Европы, Америки и Азии.

С конца 2013 года компания активно расширяет линейку поставок компонентов по направлению коаксиальный кабель, кварцевые генераторы и конденсаторы (керамические, пленочные, электролитические), за счёт заключения дистрибьюторских договоров

Мы предлагаем:

- Конкурентоспособные цены и скидки постоянным клиентам.
- Специальные условия для постоянных клиентов.
- Подбор аналогов.
- Поставку компонентов в любых объемах, удовлетворяющих вашим потребностям.
- Приемлемые сроки поставки, возможна ускоренная поставка.
- Доставку товара в любую точку России и стран СНГ.
- Комплексную поставку.
- Работу по проектам и поставку образцов.
- Формирование склада под заказчика.
- Сертификаты соответствия на поставляемую продукцию (по желанию клиента).
- Тестирование поставляемой продукции.
- Поставку компонентов, требующих военную и космическую приемку.
- Входной контроль качества.
- Наличие сертификата ISO.

В составе нашей компании организован Конструкторский отдел, призванный помогать разработчикам, и инженерам.

Конструкторский отдел помогает осуществить:

- Регистрацию проекта у производителя компонентов.
- Техническую поддержку проекта.
- Защиту от снятия компонента с производства.
- Оценку стоимости проекта по компонентам.
- Изготовление тестовой платы монтаж и пусконаладочные работы.



Тел: +7 (812) 336 43 04 (многоканальный)

Email: [org@lifeelectronics.ru](mailto:org@lifeelectronics.ru)