

VE880 Series

Dual Channel Automatic Battery Switching (ABS) VoicePort™ Device Le88221/241

APPLICATIONS

- Voice enabled Cable and DSL Modems
- Voice over IP/ATM - Integrated Access Devices (IAD)
- Smart Residential Gateways (SRG) and Routers
- Media Terminal Adapters (MTA) Standalone & Embedded
- Fiber to the User/Premise/Home (FTTH/P/H), Fiber in the Loop (FITL) Optical Network Terminals (ONT)
- Wireless Local Loop (WLL), PBX, ISDN NT1/TA
- Set-Top Box, Home Side Box

FEATURES

- **Complete BORSCHT function in a single VoicePort™ device for two channels**
 - Battery Feed, Over-voltage support, integrated Ringing, line Supervision, Codec, Hybrid (2W/4W), Test
 - Small footprint package - Exposed pad 80-pin LQFP
 - Minimal external discrete components required
- **Integrated Power Management**
 - Integrated high voltage switching regulator controllers
 - Wide input voltage range (VSW = +3.3V to +35 V)
 - Generates supplies for VBH, VBM & VBL
 - Low power Idle and On-hook transmission states
- **Ringing**
 - 5 REN with pin for pin compatible 100-V (Le88221) and 120-V (Le88241) devices
 - Up to 110-Vpk internal balanced sinusoidal or trapezoidal ringing with programmable DC offset
 - Unbalanced ringing for PBX trunk compatibility (Le88241 device)
- **Pin selectable PCM/MPI or GCI interface**
- **Worldwide Programmability**
 - Two-wire AC impedance, Balance Impedance, Gain
 - DC feed voltage and current limit
 - Ringing frequency, voltage and current limit
 - 12 kHz and 16 kHz Metering
 - Programmable loop closure and ring trip thresholds
- **G.711 μ -law, A-law, or 16 bit linear coding**
- **Powerful signal generator**
 - Universal Caller ID generation
 - Up to 4 simultaneous tones
 - Automatic cadencing feature
- **Subscriber Loop Test/Self Test support**
 - Comprehensive line sensing
 - Integrated self test capabilities
 - Line fault detection and reporting
 - Loop supervision, AC/DC faults
 - Test load switch (Le88241)
- **Integrated 150 mW 3-V or 5-V Relay Driver**
- **Pin-compatible wide band version available (16-kHz sampling mode)**

ORDERING INFORMATION

Device	Package
Le88221DLC	80-pin eLQFP (Green package*)
Le88241DLC	

*Green package meets RoHS Directive 2002/95/EC of the European Council to minimize the environmental impact of electrical equipment.

DESCRIPTION

The Zarlink dual-channel Le88221/241 Automatic Battery Switching (ABS) VoicePort™ device implements a dual-channel telephone line interface by providing all the necessary voice interface functions from the high voltage subscriber line to the μ P/DSP digital interface. The ABS device can operate from external battery supplies, or from supplies generated by the on chip switching regulator controllers. This device reduces system level cost, space, and power by achieving the highest level of voice integration possible. Designers benefit by having a simple, cost effective, low power and dense, interface design without sacrificing features or functionality. The programmable, feature rich VoicePort devices provide a highly functional line interface which meets the requirements of short and medium loop (up to 1500 Ohms total at 1 REN) applications. Features include: high voltage switching regulator, self-test, line test capabilities, integrated ringing (up to 110-Vpk), worldwide software programmability, flexible signal generator with tone cadencing, caller ID generation and all BORSCHT functions. These VoicePort device features are crucial for designing cost-effective, full-featured Voice over Broadband solutions.

VOICEPORT™ DEVICE BLOCK DIAGRAM

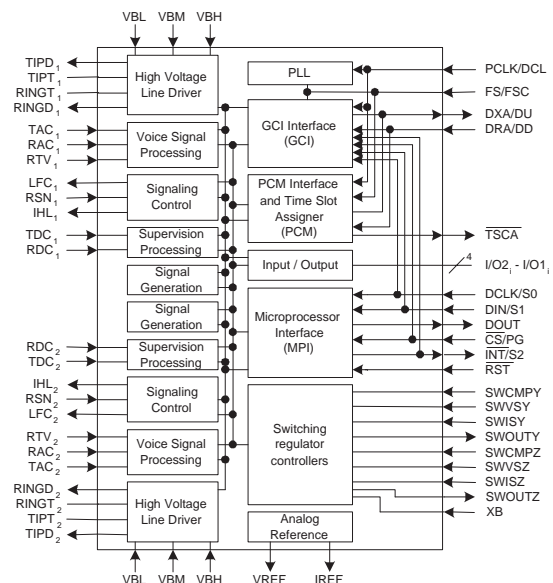

FEATURES	BENEFITS
• Highest level of integration	• Reduces system BOM and discrete component count
• Smallest footprint	• Saves board space
• Pin-compatible options	• Provides design flexibility to develop one design and populate the voice socket with the right features for a given market—100 V or 120 V, narrow band or wide band, internal balanced (sinusoidal or trapezoidal) or unbalanced ringing
• Lowest power solution across all operating modes	• Provides best solution for battery-backed and power-sensitive applications
• Highly programmable	• Offers design flexibility to develop one application for worldwide markets
• Integrated ring cadencing and system state control	• Reduces real-time software overhead
• Comprehensive line sensing	• Enables high performance 909 diagnostics and subscriber loop test and self test support
• Integrated switching regulator	• Enables lowest component count and highest efficiency in all states of operation

Related Literature

- 081265 - Le88221/241 Dual-Channel ABS Narrow band VoicePort Device Data Sheet*
- 081307- Le88226/246 Dual-Channel ABS Wide band VoicePort™ Device Data Sheet*
- 081206 - Le88116/136 Single-Channel Tracking Battery Wide Band VoicePort™ Device Data Sheet*
- Le71HR0824 - VE880 Series Line Module (Supports 2FXS ABS up to 120-V ringing with a 12-V Flyback Automatic Battery Switching Power Supply)

*Contact your Zarlink Sales Representative to obtain the data sheet.

Packaging and Availability

See *Ordering Information* on first page.

For More Information:

To find the Zarlink Sales Office nearest you, visit our website at: www.zarlink.com



**For more information about all Zarlink products
visit our Web Site at
www.zarlink.com**

Information relating to products and services furnished herein by Zarlink Semiconductor Inc. or its subsidiaries (collectively "Zarlink") is believed to be reliable. However, Zarlink assumes no liability for errors that may appear in this publication, or for liability otherwise arising from the application or use of any such information, product or service or for any infringement of patents or other intellectual property rights owned by third parties which may result from such application or use. Neither the supply of such information or purchase of product or service conveys any license, either express or implied, under patents or other intellectual property rights owned by Zarlink or licensed from third parties by Zarlink, whatsoever. Purchasers of products are also hereby notified that the use of product in certain ways or in combination with Zarlink, or non-Zarlink furnished goods or services may infringe patents or other intellectual property rights owned by Zarlink.

This publication is issued to provide information only and (unless agreed by Zarlink in writing) may not be used, applied or reproduced for any purpose nor form part of any order or contract nor to be regarded as a representation relating to the products or services concerned. The products, their specifications, services and other information appearing in this publication are subject to change by Zarlink without notice. No warranty or guarantee express or implied is made regarding the capability, performance or suitability of any product or service. Information concerning possible methods of use is provided as a guide only and does not constitute any guarantee that such methods of use will be satisfactory in a specific piece of equipment. It is the user's responsibility to fully determine the performance and suitability of any equipment using such information and to ensure that any publication or data used is up to date and has not been superseded. Manufacturing does not necessarily include testing of all functions or parameters. These products are not suitable for use in any medical products whose failure to perform may result in significant injury or death to the user. All products and materials are sold and services provided subject to Zarlink's conditions of sale which are available on request.

Purchase of Zarlink's I2C components conveys a license under the Philips I2C Patent rights to use these components in an I2C System, provided that the system conforms to the I2C Standard Specification as defined by Philips.

Zarlink, ZL, the Zarlink Semiconductor logo and the Legerity logo and combinations thereof, VoiceEdge, VoicePort, SLAC, ISLIC, ISLAC and VoicePath are trademarks of Zarlink Semiconductor Inc.

TECHNICAL DOCUMENTATION - NOT FOR RESALE

Компания «Life Electronics» занимается поставками электронных компонентов импортного и отечественного производства от производителей и со складов крупных дистрибьюторов Европы, Америки и Азии.

С конца 2013 года компания активно расширяет линейку поставок компонентов по направлению коаксиальный кабель, кварцевые генераторы и конденсаторы (керамические, пленочные, электролитические), за счёт заключения дистрибьюторских договоров

Мы предлагаем:

- Конкуренспособные цены и скидки постоянным клиентам.
- Специальные условия для постоянных клиентов.
- Подбор аналогов.
- Поставку компонентов в любых объемах, удовлетворяющих вашим потребностям.
- Приемлемые сроки поставки, возможна ускоренная поставка.
- Доставку товара в любую точку России и стран СНГ.
- Комплексную поставку.
- Работу по проектам и поставку образцов.
- Формирование склада под заказчика.
- Сертификаты соответствия на поставляемую продукцию (по желанию клиента).
- Тестирование поставляемой продукции.
- Поставку компонентов, требующих военную и космическую приемку.
- Входной контроль качества.
- Наличие сертификата ISO.

В составе нашей компании организован Конструкторский отдел, призванный помогать разработчикам, и инженерам.

Конструкторский отдел помогает осуществить:

- Регистрацию проекта у производителя компонентов.
- Техническую поддержку проекта.
- Защиту от снятия компонента с производства.
- Оценку стоимости проекта по компонентам.
- Изготовление тестовой платы монтаж и пусконаладочные работы.



Тел: +7 (812) 336 43 04 (многоканальный)
Email: org@lifeelectronics.ru