



Features

- Long life carbon element
- Assortment of resistance tapers
- 60 and 100 mm travel lengths
- Touch sense lever
- PC terminals or snap-in connector option



PSM Series Motorized Slide Potentiometer

Electrical Characteristics

Standard Resistance Range
 1K ohms to 1 megohm
 Standard Resistance Tolerance... ±20 %
 End Resistance 20 ohms max.
 Insulation Resistance @ 250 VDC
 100 megohms min.
 Dielectric Withstanding Voltage
 250 VAC
 Standard Taper Linear, Audio
 Power Rating - Linear 0.5 watt
 Power Rating - Audio 0.25 watt
 Slider Noise 47 mV max.
 Touch Sense Track
 Conductive Resistance
 Snap-in Connector..... 2 ohms max.
 PC Terminal
 TR > 30k ohms...0.1 % of TR max.
 TR ≤ 30k ohms..... 30 ohms max.

Environmental Characteristics

Operational Life 100,000 cycles
 TR Shift ±15 %
 Operating Temperature Range
 -10 °C to +55 °C
 Resistance to Solder Heat..... ±5 %

Mechanical Characteristics

Mechanical Travel
 See Product Dimensions
 Operating Force
 100 mm Travel..... 30-130 gf
 60 mm Travel..... 10-110 gf
 Stop Strength 5 kgf min.
 Shaft Wobble
 100 mm Travel..... 1.3 mm p-p max.
 60 mm Travel..... 1.6 mm p-p max.
 Soldering Condition
 Manual 350 °C ±5 °C for 3 sec.
 Wave 260 °C ±5 °C for 5 sec.
 Wash Not recommended

Motor Drive Characteristics

Rated Voltage 10 VDC
 Operating Voltage Supply .. 6 to 11 VDC
 Starting Current 800 mA max.
 Lever Speed @ 10 VDC
 20 mm/0.1 sec.

Product Dimensions

PC Terminals - 100 mm Travel

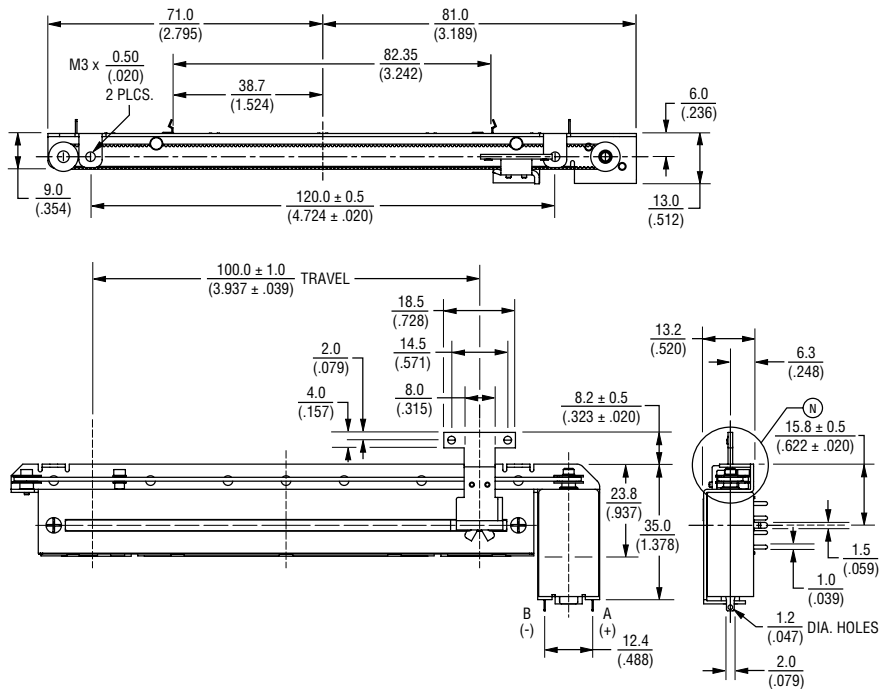

Mounting Hole Detail

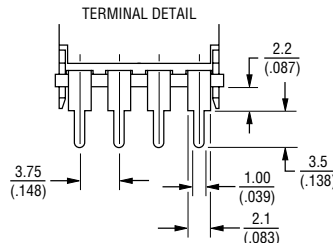
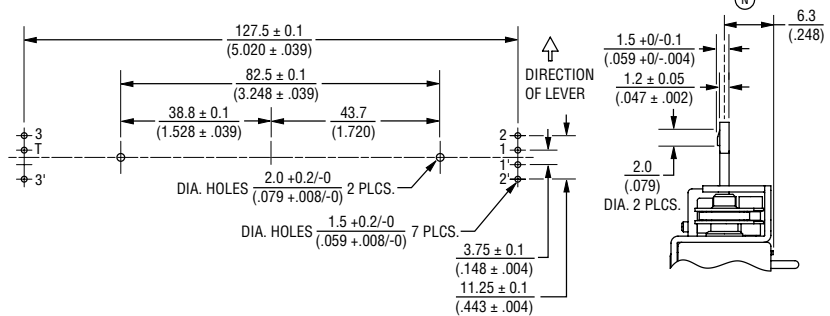

DIMENSIONS: $\frac{\text{MM}}{\text{(INCHES)}}$

*RoHS Directive 2002/95/EC Jan. 27, 2003 including annex and RoHS Recast 2011/65/EU June 8, 2011.

Specifications are subject to change without notice.

The device characteristics and parameters in this data sheet can and do vary in different applications and actual device performance may vary over time.

Users should verify actual device performance in their specific applications.

Applications

- Audio mixing consoles
- Broadcast mixing consoles

PSM Series Motorized Slide Potentiometer

BOURNS®

Product Dimensions

PC Terminals - 60 mm Travel

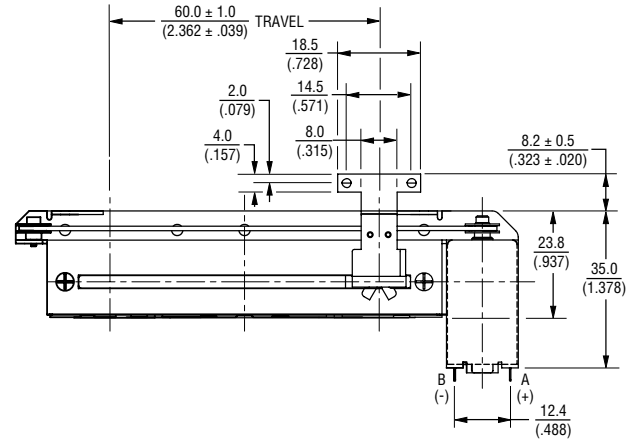
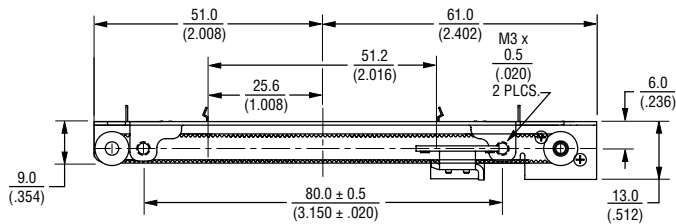

Mounting Hole Detail

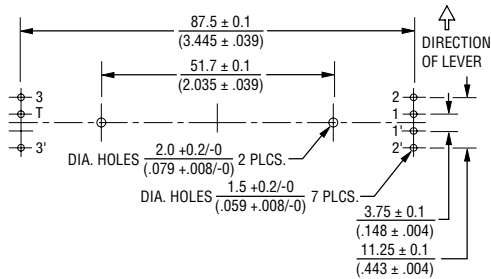

Snap-in Connector - 100 mm Travel

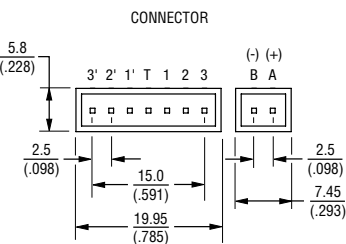
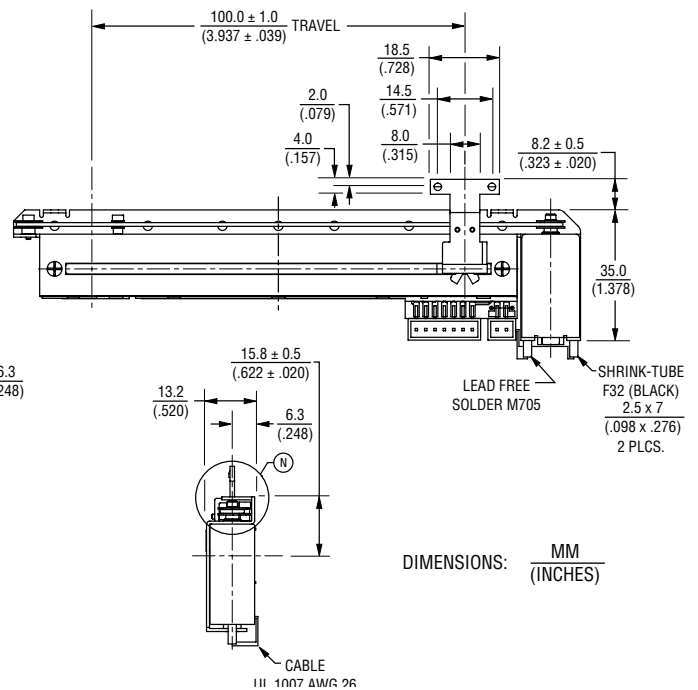
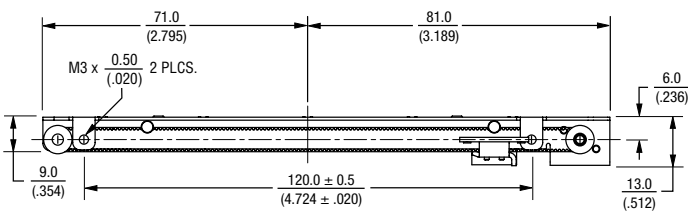

DIMENSIONS: $\frac{\text{MM}}{\text{(INCHES)}}$

Specifications are subject to change without notice.
The device characteristics and parameters in this data sheet can and do vary in different applications and actual device performance may vary over time.
Users should verify actual device performance in their specific applications.

PSM Series Motorized Slide Potentiometer

BOURNS®

Product Dimensions

Snap-in Connector - 60 mm Travel

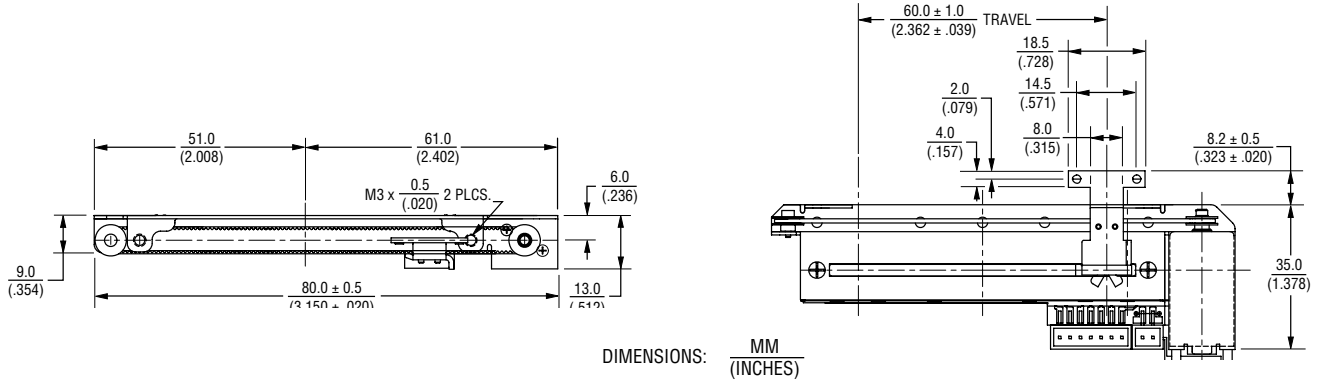

Schematics

Motor

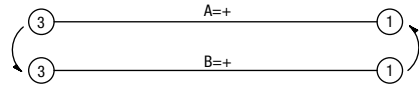
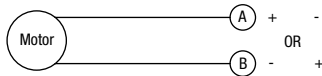

Line Track (R1)



Servo Track (R2)

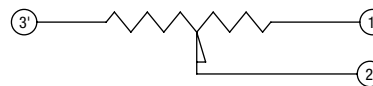

Touch Sense Track

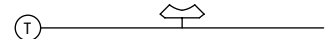

Standard Resistance Table

Resistance (Ohms)	Resistance Code
1,000	102
2,000	202
5,000	502
10,000	103
20,000	203
50,000	503
100,000	104
200,000	204
500,000	504
1,000,000	105

How To Order

PSM 01 - 08 2 A - 103 B2

Model Number _____
 Designator _____
 PSM = Motorized Slide Potentiometer
 Length of Travel _____
 01 = 100 mm
 60 = 60 mm
 Lever Length _____
 08 = 8.2 mm
 Terminal Type _____
 1 = PC Terminals
 2 = Snap-in Connector
 Lever End Style _____
 A = Metal Lever (Refer to Drawing)
 Resistance Code _____
 (See Standard Resistance Table)
 Resistance Taper (See Taper Charts) _____
 Taper Series followed by Curve Number

Servo Track Output Chart

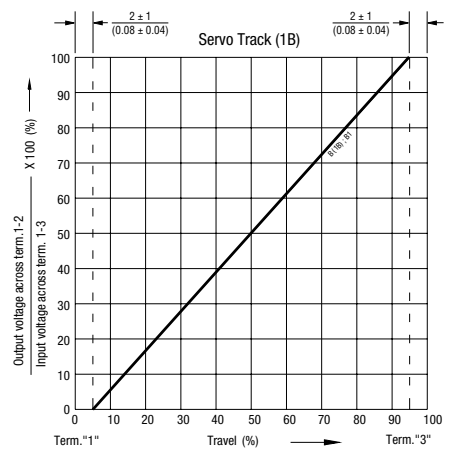

Specifications are subject to change without notice.

The device characteristics and parameters in this data sheet can and do vary in different applications and actual device performance may vary over time. Users should verify actual device performance in their specific applications.

PSM Series Motorized Slide Potentiometer

BOURNS®

Tapers

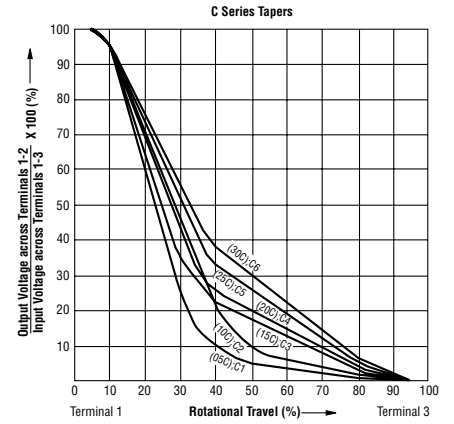
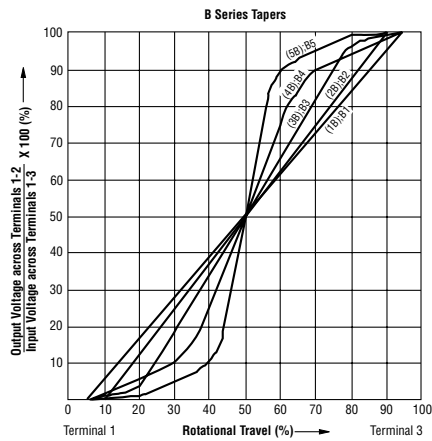
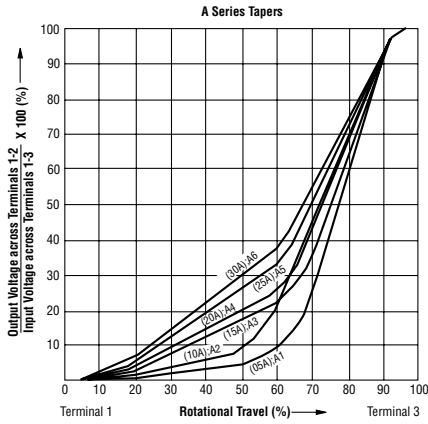

BOURNS®

Asia-Pacific: Tel: +886-2 2562-4117 • Fax: +886-2 2562-4116

EMEA: Tel: +36 88 520 390 • Fax: +36 88 520 211

The Americas: Tel: +1-951 781-5500 • Fax: +1-951 781-5700

www.bourns.com

REV. 01/16

Specifications are subject to change without notice.
The device characteristics and parameters in this data sheet can and do vary in different applications and actual device performance may vary over time.
Users should verify actual device performance in their specific applications.

Компания «Life Electronics» занимается поставками электронных компонентов импортного и отечественного производства от производителей и со складов крупных дистрибьюторов Европы, Америки и Азии.

С конца 2013 года компания активно расширяет линейку поставок компонентов по направлению коаксиальный кабель, кварцевые генераторы и конденсаторы (керамические, пленочные, электролитические), за счёт заключения дистрибьюторских договоров

Мы предлагаем:

- Конкурентоспособные цены и скидки постоянным клиентам.
- Специальные условия для постоянных клиентов.
- Подбор аналогов.
- Поставку компонентов в любых объемах, удовлетворяющих вашим потребностям.
- Приемлемые сроки поставки, возможна ускоренная поставка.
- Доставку товара в любую точку России и стран СНГ.
- Комплексную поставку.
- Работу по проектам и поставку образцов.
- Формирование склада под заказчика.
- Сертификаты соответствия на поставляемую продукцию (по желанию клиента).
- Тестирование поставляемой продукции.
- Поставку компонентов, требующих военную и космическую приемку.
- Входной контроль качества.
- Наличие сертификата ISO.

В составе нашей компании организован Конструкторский отдел, призванный помогать разработчикам, и инженерам.

Конструкторский отдел помогает осуществить:

- Регистрацию проекта у производителя компонентов.
- Техническую поддержку проекта.
- Защиту от снятия компонента с производства.
- Оценку стоимости проекта по компонентам.
- Изготовление тестовой платы монтаж и пусконаладочные работы.



Тел: +7 (812) 336 43 04 (многоканальный)
Email: org@lifeelectronics.ru