



# IS41LV16105D

## 1Mx16

## 16Mb DRAM WITH FAST PAGE MODE

MARCH 2020

### FEATURES

- TTL compatible inputs and outputs; tristate I/O
- Refresh Interval:
  - 1,024 cycles/16 ms
- Refresh Mode:
  - $\overline{\text{RAS}}$ -Only,  $\overline{\text{CAS}}$ -before- $\overline{\text{RAS}}$  (CBR), and Hidden
- JEDEC standard pinout
- Single power supply:
  - $3.3\text{V} \pm 10\%$
- Byte Write and Byte Read operation via two  $\overline{\text{CAS}}$
- Industrial Temperature Range  $-40^{\circ}\text{C}$  to  $85^{\circ}\text{C}$

### DESCRIPTION

The ISSI IS41LV16105D is a 1,048,576 x 16-bit high-performance CMOS Dynamic Random Access Memories. Fast Page Mode allows 1,024 random accesses within a single row with access cycle time as short as 20 ns per 16-bit word. It is asynchronous, as it does not require a clock signal input to synchronize commands and I/O.

These features make the IS41LV16105D ideally suited for high-bandwidth graphics, digital signal processing, high-performance computing systems, and peripheral applications that run without a clock to synchronize with the DRAM.

The IS41LV16105D is packaged in a 400-mil 50/44-pin TSOP (Type II).

### KEY TIMING PARAMETERS

Parameter	-50	Unit
Max. $\overline{\text{RAS}}$ Access Time (t <sub>RA</sub> C)	50	ns
Max. $\overline{\text{CAS}}$ Access Time (t <sub>CA</sub> C)	13	ns
Max. Column Address Access Time (t <sub>AA</sub> )	25	ns
Min. Fast Page Mode Cycle Time (t <sub>PC</sub> )	20	ns
Min. Read/Write Cycle Time (t <sub>RC</sub> )	84	ns

Copyright © 2020 Integrated Silicon Solution, Inc. All rights reserved. ISSI reserves the right to make changes to this specification and its products at any time without notice. ISSI assumes no liability arising out of the application or use of any information, products or services described herein. Customers are advised to obtain the latest version of this device specification before relying on any published information and before placing orders for products.

Integrated Silicon Solution, Inc. does not recommend the use of any of its products in life support applications where the failure or malfunction of the product can reasonably be expected to cause failure of the life support system or to significantly affect its safety or effectiveness. Products are not authorized for use in such applications unless Integrated Silicon Solution, Inc. receives written assurance to its satisfaction, that:

- a.) the risk of injury or damage has been minimized;
- b.) the user assume all such risks; and
- c.) potential liability of Integrated Silicon Solution, Inc is adequately protected under the circumstances

# IS41LV16105D

## PIN CONFIGURATIONS

### 44(50)-Pin TSOP (Type II)

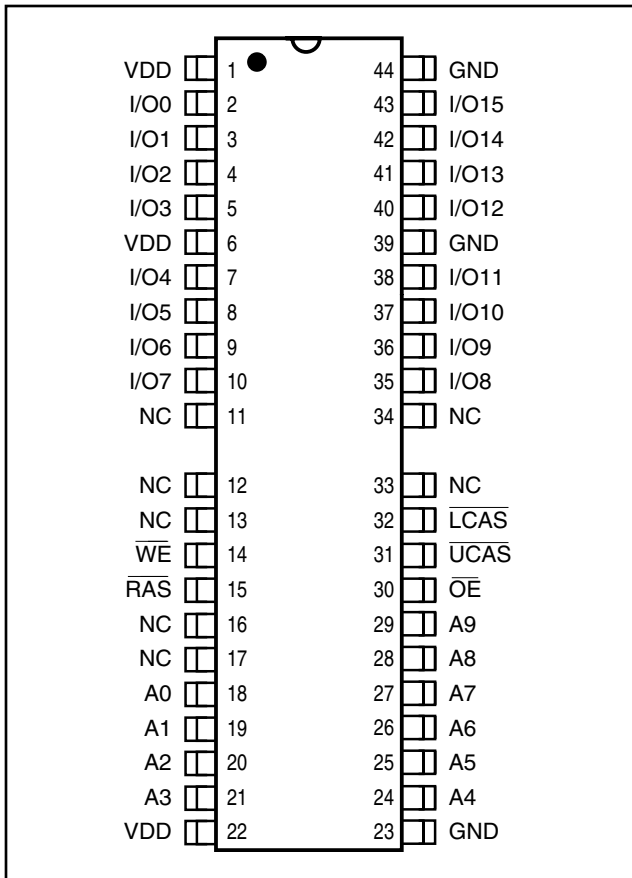

## PIN DESCRIPTIONS

A0-A9	Address Inputs
I/O0-15	Data Inputs/Outputs
WE	Write Enable
OE	Output Enable
RAS	Row Address Strobe
UCAS	Upper Column Address Strobe
LCAS	Lower Column Address Strobe
VDD	Power
GND	Ground
NC	No Connection

FUNCTIONAL BLOCK DIAGRAM

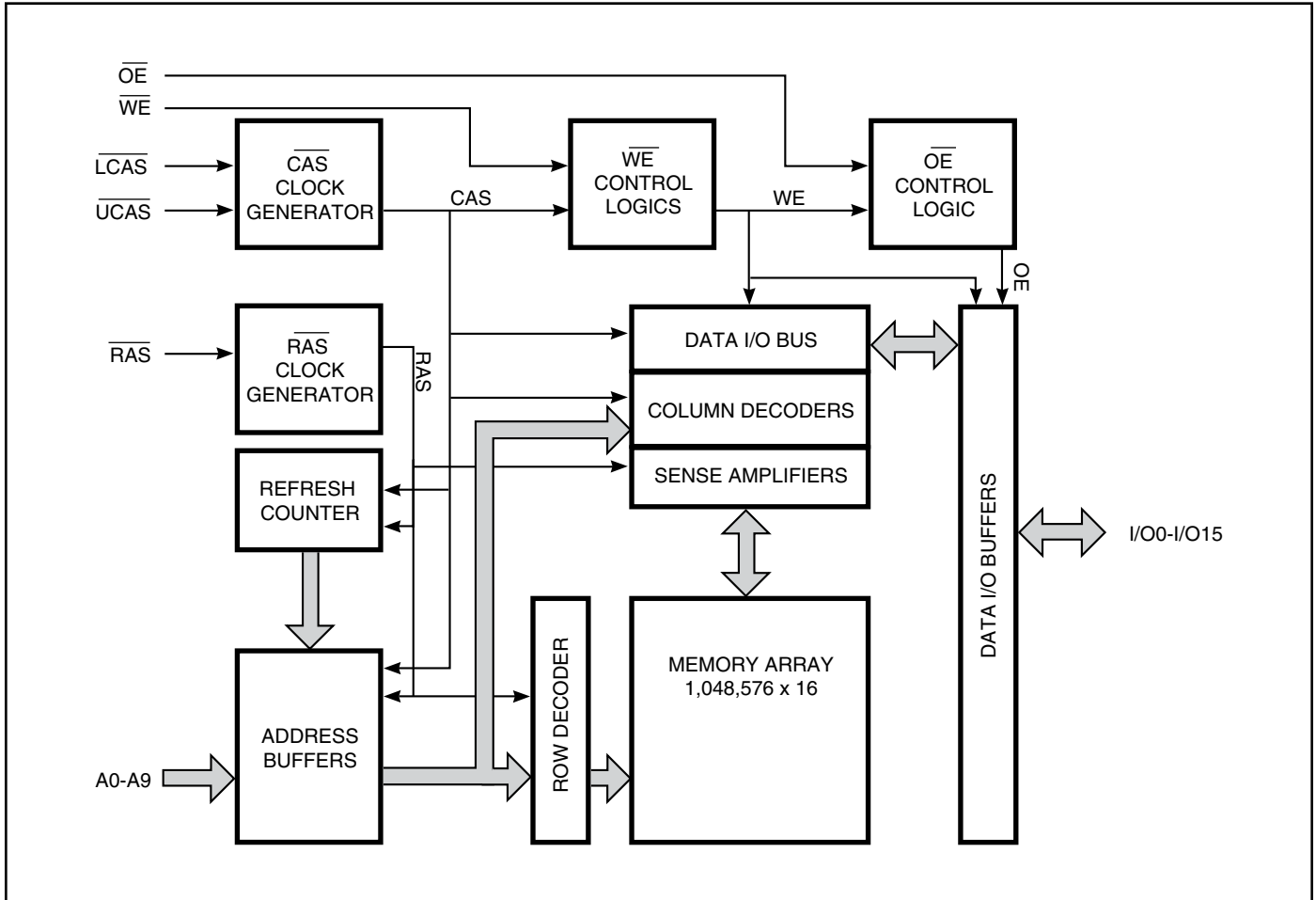

**TRUTH TABLE<sup>(5)</sup>**

Function	$\overline{\text{RAS}}$	$\overline{\text{LCAS}}$	$\overline{\text{UCAS}}$	$\overline{\text{WE}}$	$\overline{\text{OE}}$	Address tr/tc	I/O	
Standby	H	X	X	X	X	X	High-Z	
Read: Word	L	L	L	H	L	ROW/COL	DOUT	
Read: Lower Byte	L	L	H	H	L	ROW/COL	Lower Byte, DOUT Upper Byte, High-Z	
Read: Upper Byte	L	H	L	H	L	ROW/COL	Lower Byte, High-Z Upper Byte, DOUT	
Write: Word (Early Write)	L	L	L	L	X	ROW/COL	DIN	
Write: Lower Byte (Early Write)	L	L	H	L	X	ROW/COL	Lower Byte, DIN Upper Byte, High-Z	
Write: Upper Byte (Early Write)	L	H	L	L	X	ROW/COL	Lower Byte, High-Z Upper Byte, DIN	
Read-Write <sup>(1,2)</sup>	L	L	L	H→L	L→H	ROW/COL	DOUT, DIN	
Hidden Refresh	Read <sup>(2)</sup>	L→H→L	L	L	H	L	ROW/COL	DOUT
	Write <sup>(1,3)</sup>	L→H→L	L	L	L	X	ROW/COL	DOUT
$\overline{\text{RAS}}$ -Only Refresh	L	H	H	X	X	ROW/NA	High-Z	
CBR Refresh <sup>(4)</sup>	H→L	L	L	H	X	X	High-Z	

**Notes:**

1. These WRITE cycles may also be BYTE WRITE cycles (either  $\overline{\text{LCAS}}$  or  $\overline{\text{UCAS}}$  active).
2. These READ cycles may also be BYTE READ cycles (either  $\overline{\text{LCAS}}$  or  $\overline{\text{UCAS}}$  active).
3. EARLY WRITE only.
4. At least one of the two  $\overline{\text{CAS}}$  signals must be active ( $\overline{\text{LCAS}}$  or  $\overline{\text{UCAS}}$ ).
5. Commands valid only after initialization.

## Functional Description

The IS41LV16105D is a CMOS DRAM optimized for high-speed bandwidth, low power applications. During READ or WRITE cycles, each bit is uniquely addressed through the 16 address bits. These are entered ten bits (A0-A9) at a time. The row address is latched by the Row Address Strobe ( $\overline{\text{RAS}}$ ). The column address is latched by the Column Address Strobe ( $\overline{\text{CAS}}$ ).  $\overline{\text{RAS}}$  is used to latch the first nine bits and  $\overline{\text{CAS}}$  is used the latter nine bits.

The IS41LV16105D has two  $\overline{\text{CAS}}$  controls,  $\overline{\text{LCAS}}$  and  $\overline{\text{UCAS}}$ . The  $\overline{\text{LCAS}}$  and  $\overline{\text{UCAS}}$  inputs internally generates a  $\overline{\text{CAS}}$  signal functioning in an identical manner to the single  $\overline{\text{CAS}}$  input on the other 1M x 16 DRAMs. The key difference is that each  $\overline{\text{CAS}}$  controls its corresponding I/O tristate logic (in conjunction with  $\overline{\text{OE}}$  and  $\overline{\text{WE}}$  and  $\overline{\text{RAS}}$ ).  $\overline{\text{LCAS}}$  controls I/O0 through I/O7 and  $\overline{\text{UCAS}}$  controls I/O8 through I/O15.

The IS41LV16105D  $\overline{\text{CAS}}$  function is determined by the first  $\overline{\text{CAS}}$  ( $\overline{\text{LCAS}}$  or  $\overline{\text{UCAS}}$ ) transitioning LOW and the last transitioning back HIGH. The two  $\overline{\text{CAS}}$  controls give the IS41LV16105D both BYTE READ and BYTE WRITE cycle capabilities.

## Memory Cycle

A memory cycle is initiated by bring  $\overline{\text{RAS}}$  LOW and it is terminated by returning both  $\overline{\text{RAS}}$  and  $\overline{\text{CAS}}$  HIGH. To ensure proper device operation and data integrity any memory cycle, once initiated, must not be ended or aborted before the minimum  $t_{\text{RAS}}$  time has expired. A new cycle must not be initiated until the minimum precharge time  $t_{\text{RP}}$ ,  $t_{\text{CP}}$  has elapsed.

## Read Cycle

A read cycle is initiated by the falling edge of  $\overline{\text{CAS}}$  or  $\overline{\text{OE}}$ , whichever occurs last, while holding  $\overline{\text{WE}}$  HIGH. The column address must be held for a minimum time specified by  $t_{\text{AR}}$ . Data Out becomes valid only when  $t_{\text{RAC}}$ ,  $t_{\text{AA}}$ ,  $t_{\text{CAC}}$  and  $t_{\text{OEA}}$  are all satisfied. As a result, the access time is dependent on the timing relationships between these parameters.

## Write Cycle

A write cycle is initiated by the falling edge of  $\overline{\text{CAS}}$  and  $\overline{\text{WE}}$ , whichever occurs last. The input data must be valid at or before the falling edge of  $\overline{\text{CAS}}$  or  $\overline{\text{WE}}$ , whichever occurs last.

## Refresh Cycle

To retain data, 1,024 refresh cycles are required in each 16 ms period. There are two ways to refresh the memory.

1. By clocking each of the 1,024 row addresses (A0 through A9) with  $\overline{\text{RAS}}$  at least once every  $t_{\text{REF}} \text{max}$ . Any read, write, read-modify-write or  $\overline{\text{RAS}}$ -only cycle refreshes the addressed row.
2. Using a  $\overline{\text{CAS}}$ -before- $\overline{\text{RAS}}$  refresh cycle.  $\overline{\text{CAS}}$ -before- $\overline{\text{RAS}}$  refresh is activated by the falling edge of  $\overline{\text{RAS}}$ , while holding  $\overline{\text{CAS}}$  LOW. In  $\overline{\text{CAS}}$ -before- $\overline{\text{RAS}}$  refresh cycle, an internal 9-bit counter provides the row addresses and the external address inputs are ignored.

$\overline{\text{CAS}}$ -before- $\overline{\text{RAS}}$  is a refresh-only mode and no data access or device selection is allowed. Thus, the output remains in the High-Z state during the cycle.

## Power-On

During Power-On,  $\overline{\text{RAS}}$ ,  $\overline{\text{UCAS}}$ ,  $\overline{\text{LCAS}}$ , and  $\overline{\text{WE}}$  must all track with  $V_{\text{DD}}$  (HIGH) to avoid current surges, and allow initialization to continue. An initial pause of 200  $\mu\text{s}$  is required followed by a minimum of eight initialization cycles (any combination of cycles containing a  $\overline{\text{RAS}}$  signal).

# IS41LV16105D

## ABSOLUTE MAXIMUM RATINGS<sup>(1)</sup>

Symbol	Parameters	Rating	Unit
V <sub>T</sub>	Voltage on Any Pin Relative to GND	-0.5 to +4.6	V
V <sub>DD</sub>	Supply Voltage	-0.5 to +4.6	V
I <sub>OUT</sub>	Output Current	50	mA
P <sub>D</sub>	Power Dissipation	1	W
T <sub>A</sub>	Industrial Temperature	-40 to +85	°C
T <sub>STG</sub>	Storage Temperature	-55 to +125	°C

### Note:

- Stress greater than those listed under ABSOLUTE MAXIMUM RATINGS may cause permanent damage to the device. This is a stress rating only and functional operation of the device at these or any other conditions above those indicated in the operational sections of this specification is not implied. Exposure to absolute maximum rating conditions for extended periods may affect reliability.

## RECOMMENDED OPERATING CONDITIONS (Voltages are referenced to GND.)

Symbol	Parameter	Test Condition	Min.	Typ.	Max.	Unit
V <sub>DD</sub>	Supply Voltage		3.0	3.3	3.6	V
V <sub>IH</sub>	Input High Voltage		2.0	—	V <sub>DD</sub> + 0.3	V
V <sub>IL</sub>	Input Low Voltage		-0.3	—	0.8	V
I <sub>IL</sub>	Input Leakage Current	Any input $0V \leq V_{IN} \leq V_{DD}$ Other inputs not under test = 0V	-5		5	μA
I <sub>IO</sub>	Output Leakage Current	Output is disabled (Hi-Z) $0V \leq V_{OUT} \leq V_{DD}$	-5		5	μA
V <sub>OH</sub>	Output High Voltage Level	I <sub>OH</sub> = -2.0 mA	2.4		—	V
V <sub>OL</sub>	Output Low Voltage Level	I <sub>OL</sub> = 2.0 mA	—		0.4	V

## CAPACITANCE<sup>(1,2)</sup>

Symbol	Parameter	Max.	Unit
C <sub>IN1</sub>	Input Capacitance: A0-A9	5	pF
C <sub>IN2</sub>	Input Capacitance: $\overline{RAS}$ , $\overline{UCAS}$ , $\overline{LCAS}$ , $\overline{WE}$ , $\overline{OE}$	7	pF
C <sub>IO</sub>	Data Input/Output Capacitance: I/O0-I/O15	7	pF

### Notes:

- Tested initially and after any design or process changes that may affect these parameters.
- Test conditions: T<sub>A</sub> = 25°C, f = 1 MHz,

**ELECTRICAL CHARACTERISTICS<sup>(1)</sup>** (Recommended Operation Conditions unless otherwise noted.)

Symbol	Parameter	Test Condition	Max.	Unit
I <sub>DD1</sub>	Stand-by Current: TTL	$\overline{RAS}, \overline{LCAS}, \overline{UCAS} \geq V_{IH}$	2	mA
I <sub>DD2</sub>	Stand-by Current: CMOS	$\overline{RAS}, \overline{LCAS}, \overline{UCAS} \geq V_{DD} - 0.2V$	1	mA
I <sub>DD3</sub>	Operating Current: Random Read/Write <sup>(2,3,4)</sup> Average Power Supply Current	$\overline{RAS}, \overline{LCAS}, \overline{UCAS}$ , Address Cycling, $t_{RC} = t_{RC}(\text{min.})$	90	mA
I <sub>DD4</sub>	Operating Current: Fast Page Mode <sup>(2,3,4)</sup> Average Power Supply Current	$\overline{RAS} = V_{IL}, \overline{LCAS}, \overline{UCAS}$ , Cycling $t_{PC} = t_{PC}(\text{min.})$	30	mA
I <sub>DD5</sub>	Refresh Current: $\overline{RAS}$ -Only <sup>(2,3)</sup> Average Power Supply Current	$\overline{RAS}$ Cycling, $\overline{LCAS}, \overline{UCAS} \geq V_{IH}$ $t_{RC} = t_{RC}(\text{min.})$	60	mA
I <sub>DD6</sub>	Refresh Current: CBR <sup>(2,3,5)</sup> Average Power Supply Current	$\overline{RAS}, \overline{LCAS}, \overline{UCAS}$ Cycling $t_{RC} = t_{RC}(\text{min.})$	60	mA

**Notes:**

1. An initial pause of 200  $\mu\text{s}$  is required after power-up followed by eight  $\overline{RAS}$  refresh cycles ( $\overline{RAS}$ -Only or CBR) before proper device operation is assured. The eight  $\overline{RAS}$  cycles wake-up should be repeated any time the  $t_{REF}$  refresh requirement is exceeded.
2. Dependent on cycle rates.
3. Specified values are obtained with minimum cycle time and the output open.
4. Column-address is changed once each EDO page cycle.
5. Enables on-chip refresh and address counters.

**AC CHARACTERISTICS**<sup>(1,2,3,4,5,6)</sup>

(Recommended Operating Conditions unless otherwise noted.)

Symbol	Parameter	-50		-60		Units
		Min.	Max.	Min.	Max.	
tRC	Random READ or WRITE Cycle Time	84	—	104	—	ns
tRAC	Access Time from $\overline{\text{RAS}}^{(6, 7)}$	—	50	—	60	ns
tCAC	Access Time from $\overline{\text{CAS}}^{(6, 8, 15)}$	—	13	—	15	ns
tAA	Access Time from Column-Address <sup>(6)</sup>	—	25	—	30	ns
tRAS	$\overline{\text{RAS}}$ Pulse Width	50	10K	60	10K	ns
tRP	$\overline{\text{RAS}}$ Precharge Time	30	—	40	—	ns
tCAS	$\overline{\text{CAS}}$ Pulse Width <sup>(26)</sup>	8	10K	10	10K	ns
tCP	$\overline{\text{CAS}}$ Precharge Time <sup>(9, 25)</sup>	9	—	9	—	ns
tCSH	$\overline{\text{CAS}}$ Hold Time <sup>(21)</sup>	38	—	40	—	ns
tRCD	$\overline{\text{RAS}}$ to $\overline{\text{CAS}}$ Delay Time <sup>(10, 20)</sup>	12	37	14	45	ns
tASR	Row-Address Setup Time	0	—	0	—	ns
tRAH	Row-Address Hold Time	8	—	10	—	ns
tASC	Column-Address Setup Time <sup>(20)</sup>	0	—	0	—	ns
tCAH	Column-Address Hold Time <sup>(20)</sup>	8	—	10	—	ns
tAR	Column-Address Hold Time (referenced to $\overline{\text{RAS}}$ )	30	—	40	—	ns
tRAD	$\overline{\text{RAS}}$ to Column-Address Delay Time <sup>(11)</sup>	10	25	12	30	ns
tRAL	Column-Address to $\overline{\text{RAS}}$ Lead Time	25	—	30	—	ns
tRPC	$\overline{\text{RAS}}$ to $\overline{\text{CAS}}$ Precharge Time	5	—	5	—	ns
tRSH	$\overline{\text{RAS}}$ Hold Time <sup>(27)</sup>	8	—	10	—	ns
tRHCP	$\overline{\text{RAS}}$ Hold Time from $\overline{\text{CAS}}$ Precharge	37	—	37	—	ns
tCLZ	$\overline{\text{CAS}}$ to Output in Low-Z <sup>(15, 29)</sup>	0	—	0	—	ns
tCRP	$\overline{\text{CAS}}$ to $\overline{\text{RAS}}$ Precharge Time <sup>(21)</sup>	5	—	5	—	ns
tOD	Output Disable Time <sup>(19, 28, 29)</sup>	3	15	3	15	ns
tOE	Output Enable Time <sup>(15, 16)</sup>	—	13	—	15	ns
toED	Output Enable Data Delay (Write)	20	—	20	—	ns
toEHC	$\overline{\text{OE}}$ HIGH Hold Time from $\overline{\text{CAS}}$ HIGH	5	—	5	—	ns
toEP	$\overline{\text{OE}}$ HIGH Pulse Width	10	—	10	—	ns
toES	$\overline{\text{OE}}$ LOW to $\overline{\text{CAS}}$ HIGH Setup Time	5	—	5	—	ns
tRCS	Read Command Setup Time <sup>(17, 20)</sup>	0	—	0	—	ns
tRRH	Read Command Hold Time (referenced to $\overline{\text{RAS}}$ ) <sup>(12)</sup>	0	—	0	—	ns
tRCH	Read Command Hold Time (referenced to $\overline{\text{CAS}}$ ) <sup>(12, 17, 21)</sup>	0	—	0	—	ns
twCH	Write Command Hold Time <sup>(17, 27)</sup>	8	—	10	—	ns



# IS41LV16105D

## AC CHARACTERISTICS (Continued)<sup>(1,2,3,4,5,6)</sup>

(Recommended Operating Conditions unless otherwise noted.)

Symbol	Parameter	-50		-60		Units
		Min.	Max.	Min.	Max.	
tWCR	Write Command Hold Time (referenced to $\overline{\text{RAS}}$ ) <sup>(17)</sup>	40	—	50	—	ns
tWP	Write Command Pulse Width <sup>(17)</sup>	8	—	10	—	ns
tWPZ	$\overline{\text{WE}}$ Pulse Widths to Disable Outputs	10	—	10	—	ns
trWL	Write Command to $\overline{\text{RAS}}$ Lead Time <sup>(17)</sup>	13	—	15	—	ns
tcWL	Write Command to $\overline{\text{CAS}}$ Lead Time <sup>(17, 21)</sup>	8	—	10	—	ns
twCS	Write Command Setup Time <sup>(14, 17, 20)</sup>	0	—	0	—	ns
tdHR	Data-in Hold Time (referenced to $\overline{\text{RAS}}$ )	39	—	39	—	ns
tACH	Column-Address Setup Time to $\overline{\text{CAS}}$ Precharge during WRITE Cycle	15	—	15	—	ns
toEH	$\overline{\text{OE}}$ Hold Time from $\overline{\text{WE}}$ during READ-MODIFY-WRITE cycle <sup>(18)</sup>	8	—	10	—	ns
tDS	Data-In Setup Time <sup>(15, 22)</sup>	0	—	0	—	ns
tdH	Data-In Hold Time <sup>(15, 22)</sup>	8	—	10	—	ns
trWC	READ-MODIFY-WRITE Cycle Time	108	—	133	—	ns
trWD	$\overline{\text{RAS}}$ to $\overline{\text{WE}}$ Delay Time during READ-MODIFY-WRITE Cycle <sup>(14)</sup>	64	—	77	—	ns
tcWD	$\overline{\text{CAS}}$ to $\overline{\text{WE}}$ Delay Time <sup>(14, 20)</sup>	26	—	32	—	ns
tAWD	Column-Address to $\overline{\text{WE}}$ Delay Time <sup>(14)</sup>	39	—	47	—	ns
tpc	Fast Page Mode READ or WRITE Cycle Time <sup>(24)</sup>	20	—	25	—	ns
trASP	$\overline{\text{RAS}}$ Pulse Width	50	100K	60	100K	ns
tCPA	Access Time from $\overline{\text{CAS}}$ Precharge <sup>(15)</sup>	—	30	—	35	ns
tPRWC	READ-WRITE Cycle Time <sup>(24)</sup>	56	—	68	—	ns
tCOH	Data Output Hold after $\overline{\text{CAS}}$ LOW	5	—	5	—	ns
toFF	Output Buffer Turn-Off Delay from $\overline{\text{CAS}}$ or $\overline{\text{RAS}}$ <sup>(13,15,19, 29)</sup>	1.6	12	1.6	15	ns
tWHZ	Output Disable Delay from $\overline{\text{WE}}$	3	10	3	10	ns
tCLCH	Last $\overline{\text{CAS}}$ going LOW to First $\overline{\text{CAS}}$ returning HIGH <sup>(23)</sup>	10	—	10	—	ns
tCSR	$\overline{\text{CAS}}$ Setup Time (CBR REFRESH) <sup>(30, 20)</sup>	5	—	5	—	ns
tCHR	$\overline{\text{CAS}}$ Hold Time (CBR REFRESH) <sup>(30, 21)</sup>	8	—	10	—	ns
tORD	$\overline{\text{OE}}$ Setup Time prior to $\overline{\text{RAS}}$ during HIDDEN REFRESH Cycle	0	—	0	—	ns
tWRP	$\overline{\text{WE}}$ Setup Time (CBR Refresh)	5	—	5	—	ns
tWRH	$\overline{\text{WE}}$ Hold Time (CBR Refresh)	8	—	10	—	ns
tREF	Auto Refresh Period (1,024 Cycles)	—	16	—	16	ms
tT	Transition Time (Rise or Fall) <sup>(2, 3)</sup>	1	50	1	50	ns

**Note:**

The -60 timing parameters are shown for reference only. The -50 speed option supports 50ns and 60ns timing specifications.

**AC TEST CONDITIONS**

Output load: One TTL Load and 50 pF

Input timing reference levels:  $V_{IH} = 2.0V$ ,  $V_{IL} = 0.8V$

Output timing reference levels:  $V_{OH} = 2.4V$ ,  $V_{OL} = 0.4V$

**Notes:**

1. An initial pause of 200  $\mu s$  is required after power-up followed by eight  $\overline{RAS}$  refresh cycle ( $\overline{RAS}$ -Only or CBR) before proper device operation is assured. The eight  $\overline{RAS}$  cycles wake-up should be repeated any time the  $t_{REF}$  refresh requirement is exceeded.
2.  $V_{IH}$  (MIN) and  $V_{IL}$  (MAX) are reference levels for measuring timing of input signals. Transition times, are measured between  $V_{IH}$  and  $V_{IL}$  (or between  $V_{IL}$  and  $V_{IH}$ ) and assume to be 1 ns for all inputs.
3. In addition to meeting the transition rate specification, all input signals must transit between  $V_{IH}$  and  $V_{IL}$  (or between  $V_{IL}$  and  $V_{IH}$ ) in a monotonic manner.
4. If  $\overline{CAS}$  and  $\overline{RAS} = V_{IH}$ , data output is High-Z.
5. If  $\overline{CAS} = V_{IL}$ , data output may contain data from the last valid READ cycle.
6. Measured with a load equivalent to one TTL gate and 50 pF.
7. Assumes that  $t_{RCD} \leq t_{RCD} (MAX)$ . If  $t_{RCD}$  is greater than the maximum recommended value shown in this table,  $t_{RAC}$  will increase by the amount that  $t_{RCD}$  exceeds the value shown.
8. Assumes that  $t_{RCD} \leq t_{RCD} (MAX)$ .
9. If  $\overline{CAS}$  is LOW at the falling edge of  $\overline{RAS}$ , data out will be maintained from the previous cycle. To initiate a new cycle and clear the data output buffer,  $\overline{CAS}$  and  $\overline{RAS}$  must be pulsed for  $t_{CP}$ .
10. Operation with the  $t_{RCD} (MAX)$  limit ensures that  $t_{RAC} (MAX)$  can be met.  $t_{RCD} (MAX)$  is specified as a reference point only; if  $t_{RCD}$  is greater than the specified  $t_{RCD} (MAX)$  limit, access time is controlled exclusively by  $t_{CAC}$ .
11. Operation within the  $t_{RAD} (MAX)$  limit ensures that  $t_{RCD} (MAX)$  can be met.  $t_{RAD} (MAX)$  is specified as a reference point only; if  $t_{RAD}$  is greater than the specified  $t_{RAD} (MAX)$  limit, access time is controlled exclusively by  $t_{AA}$ .
12. Either  $t_{RCH}$  or  $t_{RRH}$  must be satisfied for a READ cycle.
13.  $t_{OFF} (MAX)$  defines the time at which the output achieves the open circuit condition; it is not a reference to  $V_{OH}$  or  $V_{OL}$ .
14.  $t_{WCS}$ ,  $t_{RWd}$ ,  $t_{AWd}$  and  $t_{CWD}$  are restrictive operating parameters in LATE WRITE and READ-MODIFY-WRITE cycle only. If  $t_{WCS} \leq t_{WCS} (MIN)$ , the cycle is an EARLY WRITE cycle and the data output will remain open circuit throughout the entire cycle. If  $t_{RWd} \leq t_{RWd} (MIN)$ ,  $t_{AWd} \leq t_{AWd} (MIN)$  and  $t_{CWD} \leq t_{CWD} (MIN)$ , the cycle is a READ-WRITE cycle and the data output will contain data read from the selected cell. If neither of the above conditions is met, the state of I/O (at access time and until  $\overline{CAS}$  and  $\overline{RAS}$  or  $\overline{OE}$  go back to  $V_{IH}$ ) is indeterminate.  $\overline{OE}$  held HIGH and  $\overline{WE}$  taken LOW after  $\overline{CAS}$  goes LOW result in a LATE WRITE ( $\overline{OE}$ -controlled) cycle.
15. Output parameter (I/O) is referenced to corresponding  $\overline{CAS}$  input, I/O0-I/O7 by  $\overline{LCAS}$  and I/O8-I/O15 by  $\overline{UCAS}$ .
16. During a READ cycle, if  $\overline{OE}$  is LOW then taken HIGH before  $\overline{CAS}$  goes HIGH, I/O goes open. If  $\overline{OE}$  is tied permanently LOW, a LATE WRITE or READ-MODIFY-WRITE is not possible.
17. Write command is defined as  $\overline{WE}$  going low.
18. LATE WRITE and READ-MODIFY-WRITE cycles must have both  $t_{OD}$  and  $t_{OEH}$  met ( $\overline{OE}$  HIGH during WRITE cycle) in order to ensure that the output buffers will be open during the WRITE cycle. The I/Os will provide the previously written data if  $\overline{CAS}$  remains LOW and  $\overline{OE}$  is taken back to LOW after  $t_{OEH}$  is met.
19. The I/Os are in open during READ cycles once  $t_{OD}$  or  $t_{OFF}$  occur.
20. The first  $\chi\overline{CAS}$  edge to transition LOW.
21. The last  $\chi\overline{CAS}$  edge to transition HIGH.
22. These parameters are referenced to  $\overline{CAS}$  leading edge in EARLY WRITE cycles and  $\overline{WE}$  leading edge in LATE WRITE or READ-MODIFY-WRITE cycles.
23. Last falling  $\chi\overline{CAS}$  edge to first rising  $\chi\overline{CAS}$  edge.
24. Last rising  $\chi\overline{CAS}$  edge to next cycle's last rising  $\chi\overline{CAS}$  edge.
25. Last rising  $\chi\overline{CAS}$  edge to first falling  $\chi\overline{CAS}$  edge.
26. Each  $\chi\overline{CAS}$  must meet minimum pulse width.
27. Last  $\chi\overline{CAS}$  to go LOW.
28. I/Os controlled, regardless  $\overline{UCAS}$  and  $\overline{LCAS}$ .
29. The 3 ns minimum is a parameter guaranteed by design.
30. Enables on-chip refresh and address counters.

FAST-PAGE-MODE READ CYCLE

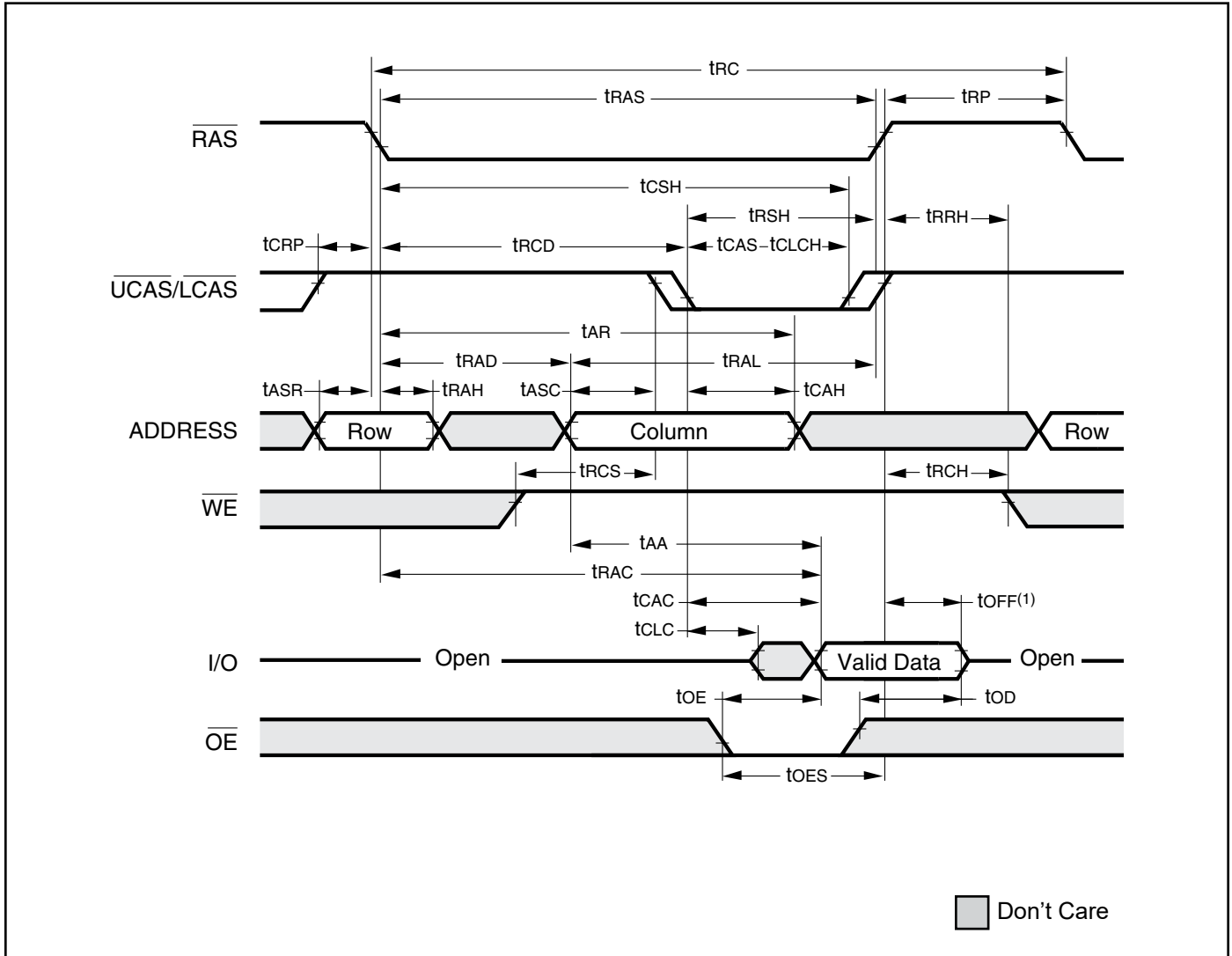

**Note:**

1.  $t_{OFF}$  is referenced from rising edge of  $\overline{RAS}$  or  $\overline{CAS}$ , whichever occurs last.

FAST PAGE MODE READ-MODIFY-WRITE CYCLE

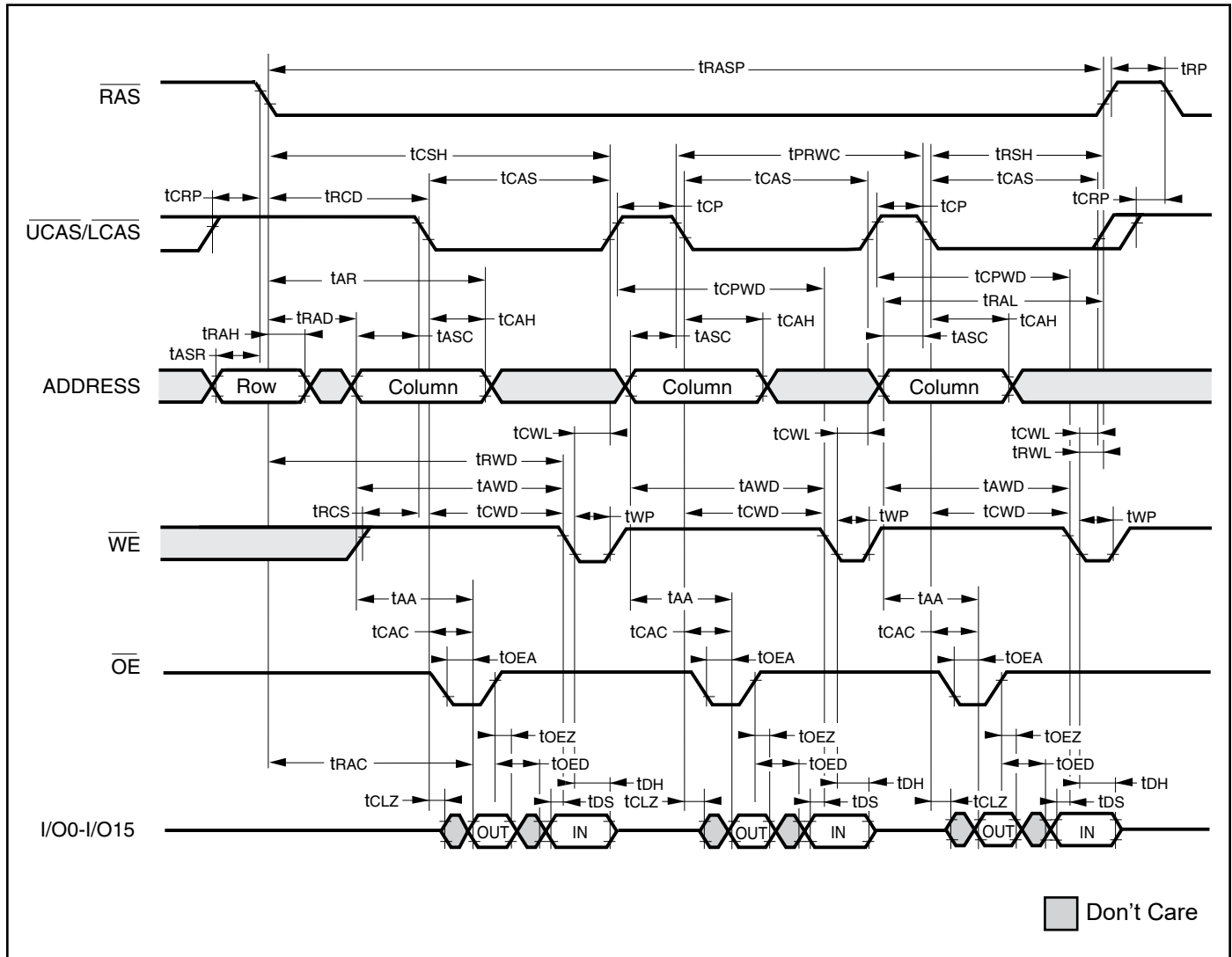

FAST-PAGE-MODE EARLY WRITE CYCLE ( $\overline{OE}$  = DON'T CARE)

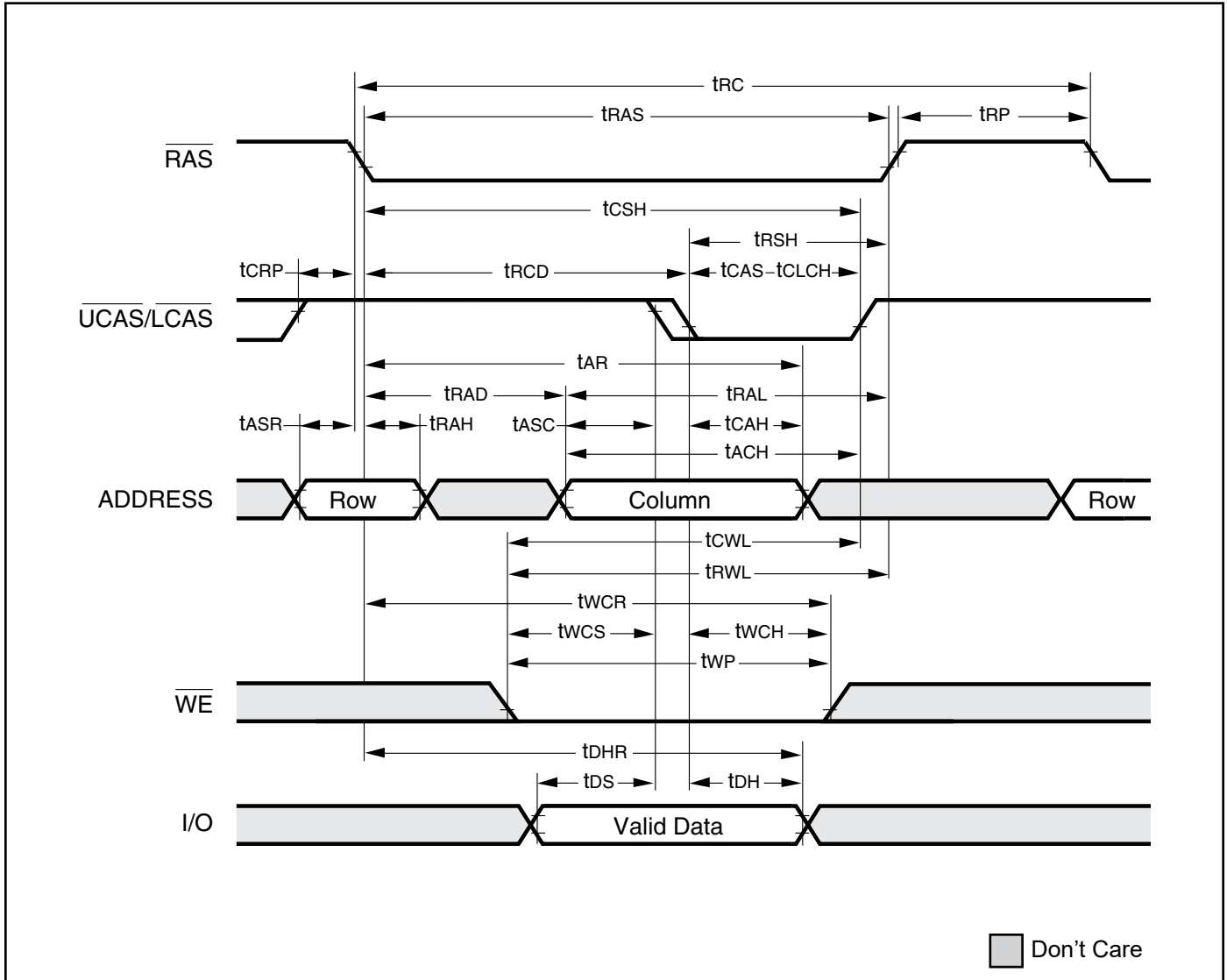

**FAST-PAGE-MODE READ WRITE CYCLE (LATE WRITE and READ-MODIFY-WRITE Cycles)**

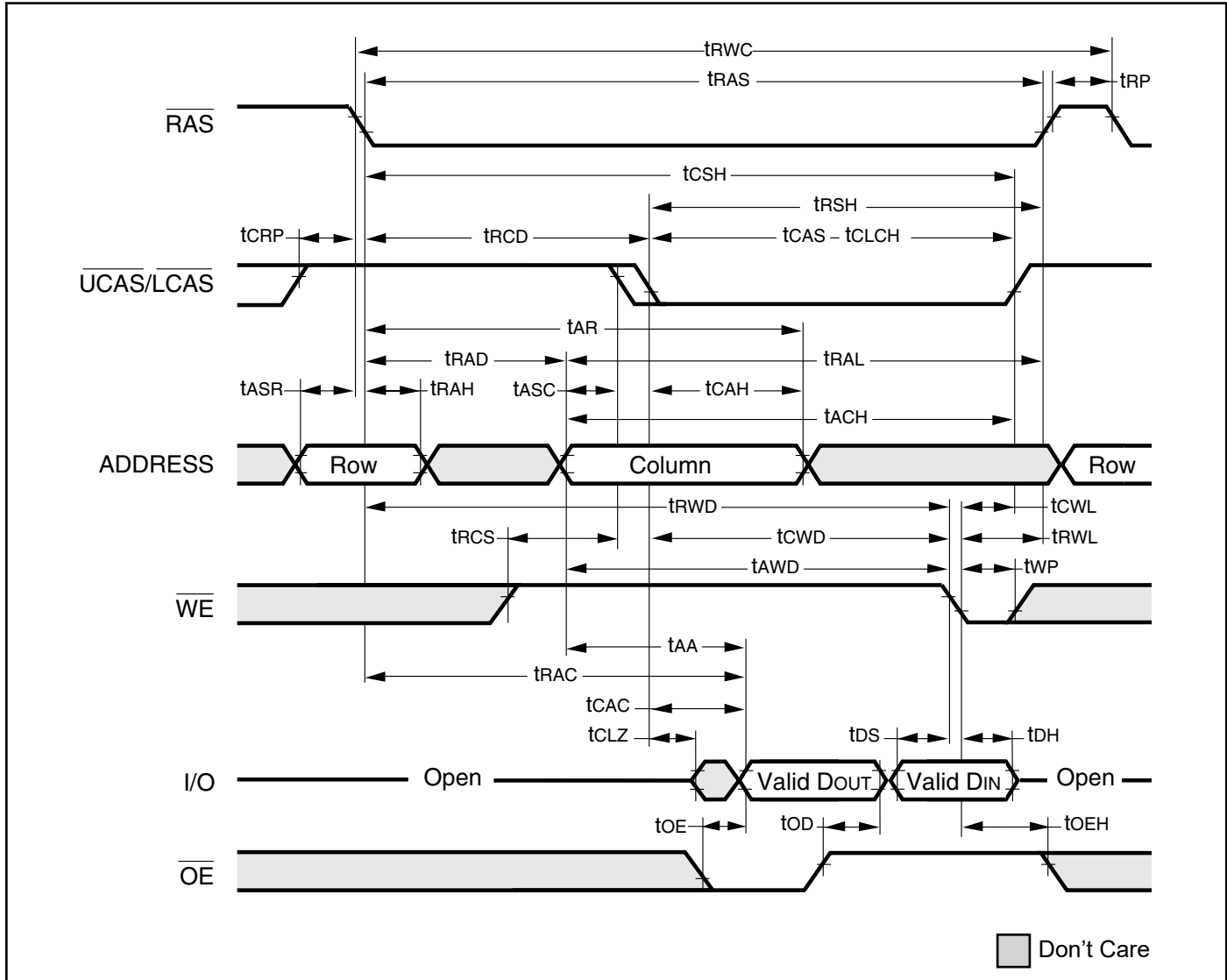

FAST PAGE MODE EARLY WRITE CYCLE

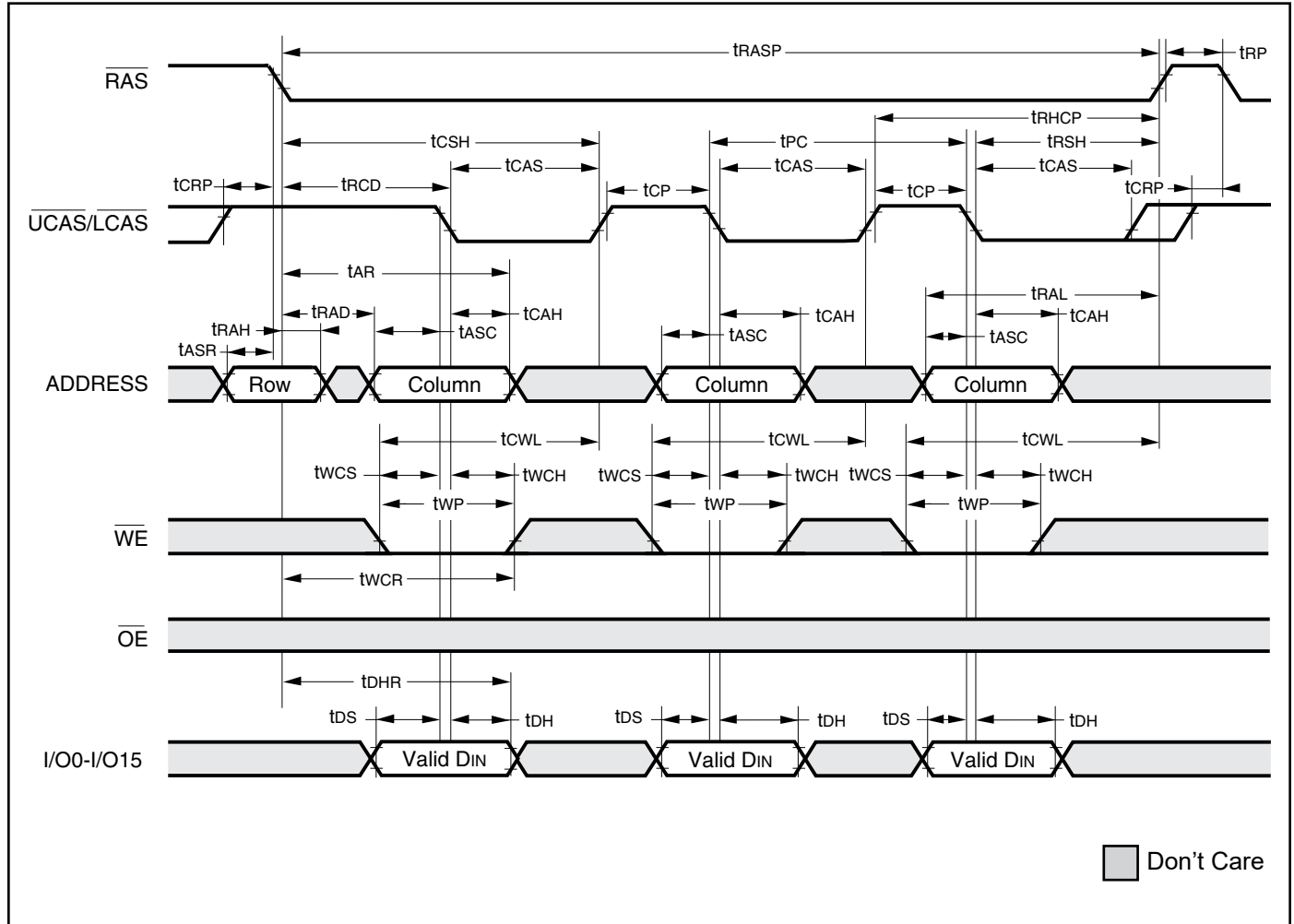

AC WAVEFORMS

READ CYCLE (With  $\overline{WE}$ -Controlled Disable)

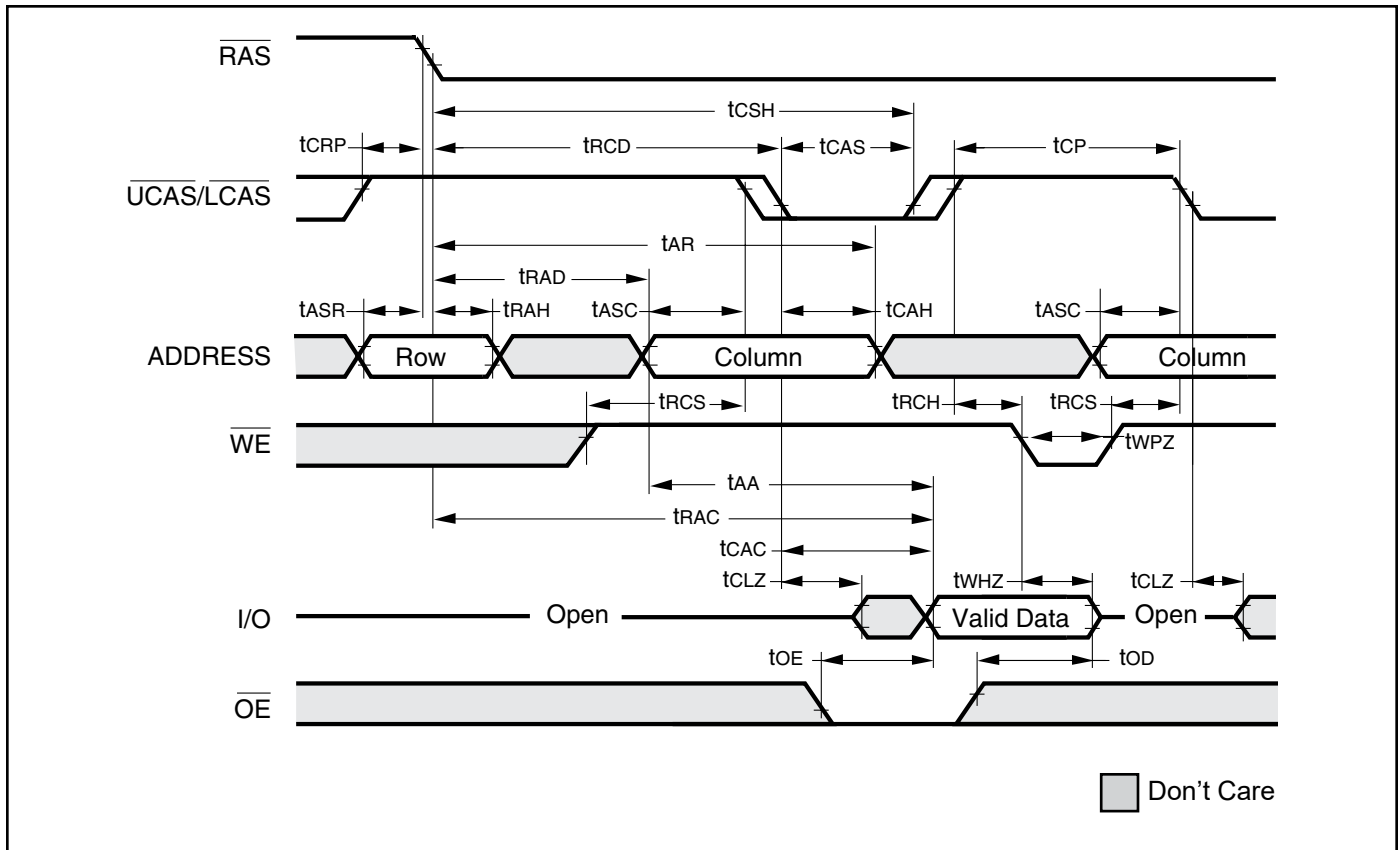

RAS-ONLY REFRESH CYCLE ( $\overline{OE}$ ,  $\overline{WE}$  = DON'T CARE)

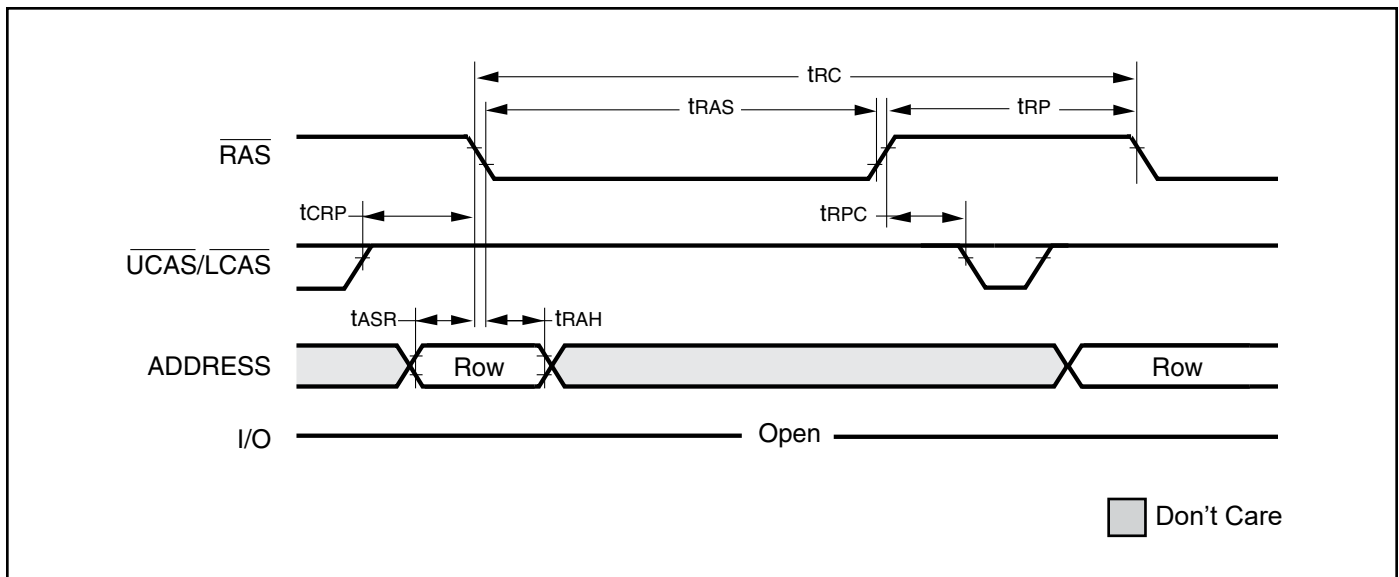



# IS41LV16105D

## CBR REFRESH CYCLE (Addresses; $\overline{OE}$ = DON'T CARE)

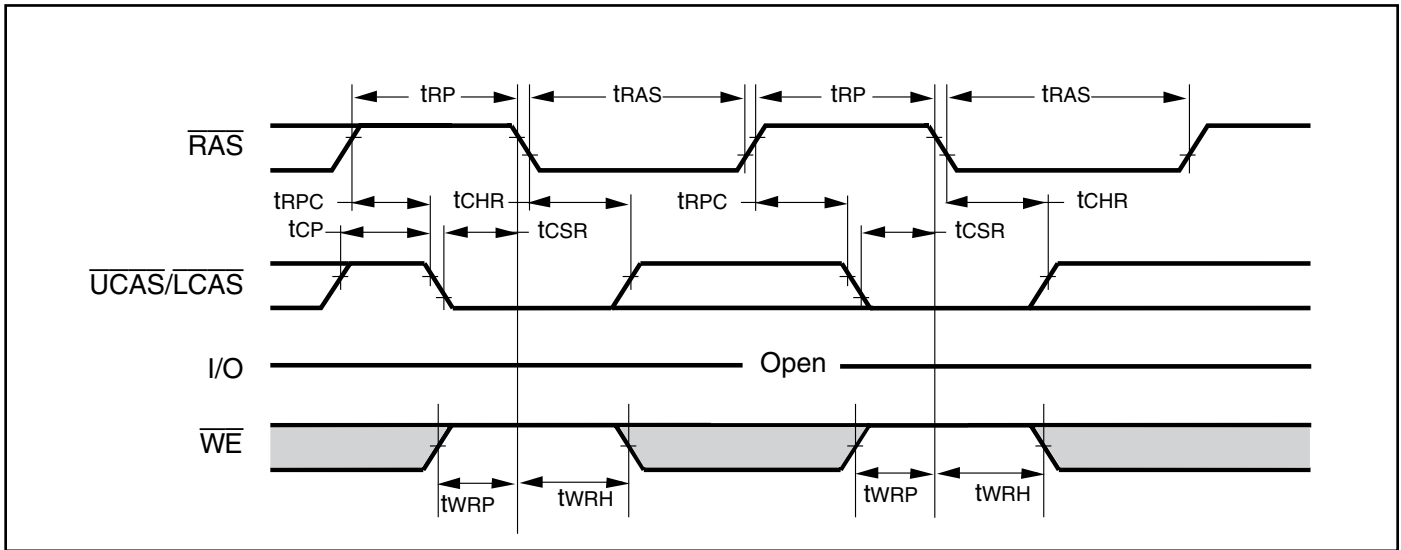

## HIDDEN REFRESH CYCLE<sup>(1)</sup> ( $\overline{WE}$ = HIGH; $\overline{OE}$ = LOW)

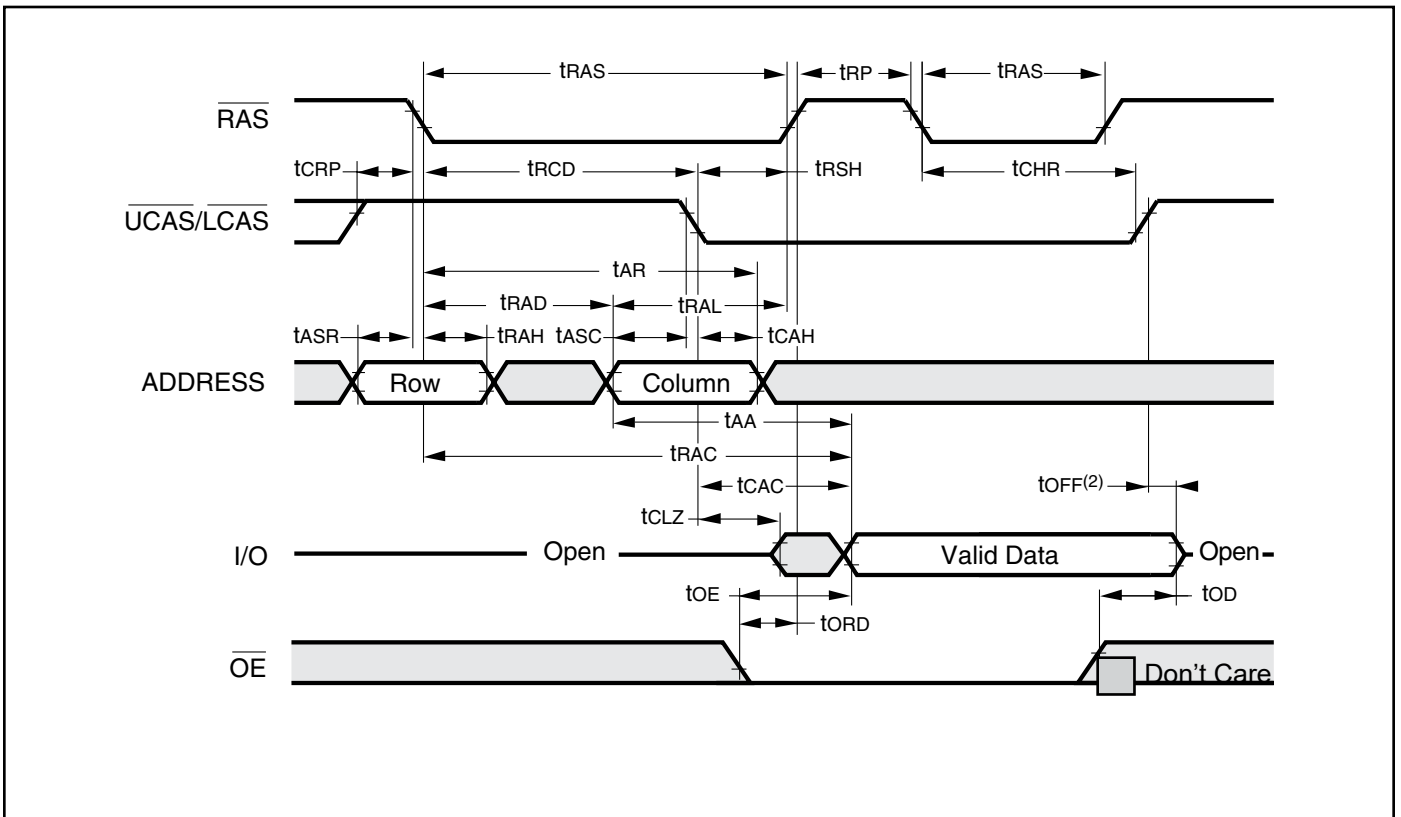

### Notes:

1. A Hidden Refresh may also be performed after a Write Cycle. In this case,  $\overline{WE}$  = LOW and  $\overline{OE}$  = HIGH.
2.  $t_{OFF}$  is referenced from rising edge of  $\overline{RAS}$  or  $\overline{CAS}$ , whichever occurs last.



## IS41LV16105D

---

### ORDERING INFORMATION :

**Industrial Range: -40°C to +85°C**

Speed (ns)	Order Part No.	Package
50	IS41LV16105D-50TLI	400-mil TSOP (Type II), Lead-free

**Note:**

The -50 speed option supports 50ns and 60ns timing specifications.

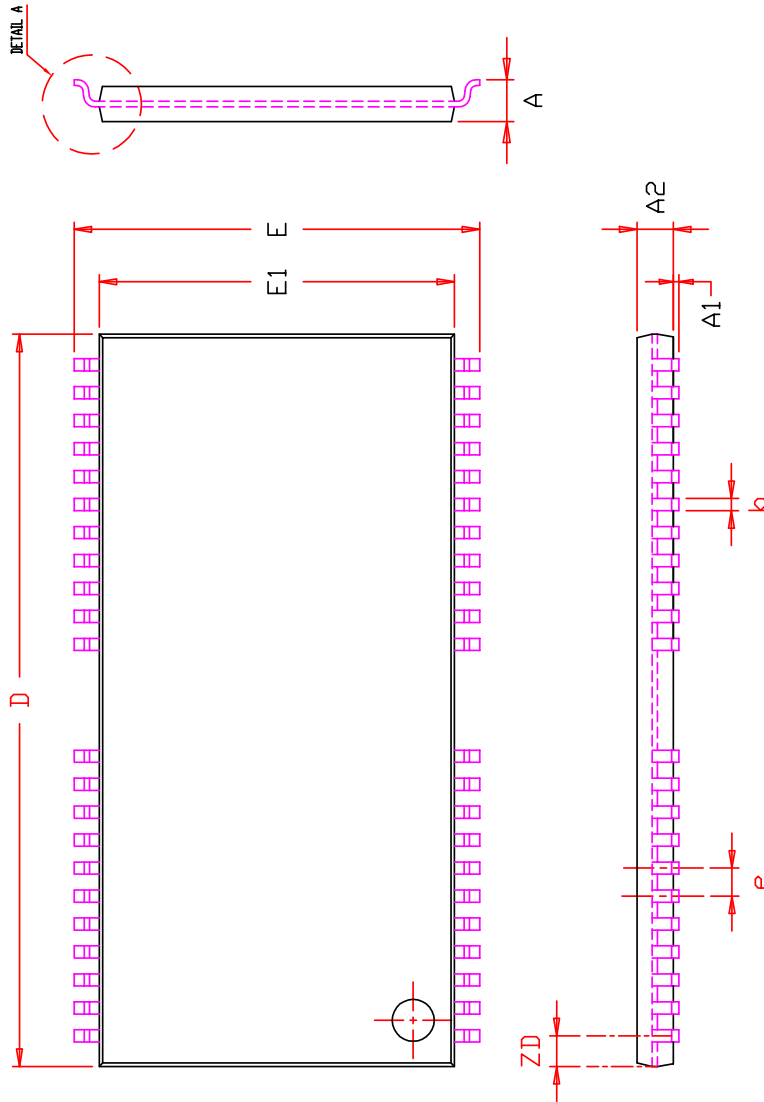

SYMBOL	DIMENSION IN MM			DIMENSION IN INCH		
	MIN.	NOM.	MAX.	MIN.	NOM.	MAX.
A	1.00		1.20	0.039		0.047
A1	0.05		0.15	0.002		0.006
A2	0.95	1.00	1.05	0.037	0.039	0.041
b	0.30		0.45	0.012		0.018
D	20.82	20.95	21.08	0.820	0.825	0.830
E	11.56	11.76	11.96	0.455	0.463	0.471
E1	10.03	10.16	10.29	0.395	0.400	0.405
e		0.80 BSC.			0.031 BSC.	
L	0.40	0.50	0.60	0.016	0.020	0.024
L1		0.25 BSC.			0.010 BSC.	
ZD		0.875 REF.			0.034 REF.	
θ	0		8°	0		8°

**NOTE :**

1. CONTROLLING DIMENSION : MM
2. DIMENSION D AND E1 DO NOT INCLUDE MOLD PROTRUSION.
3. DIMENSION b DOES NOT INCLUDE DAMBAR PROTRUSION/INTRUSION.

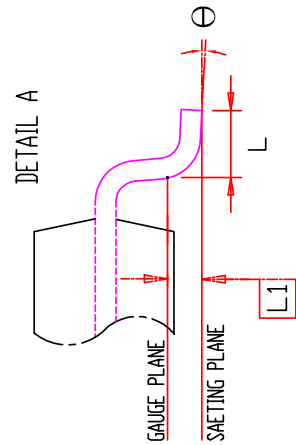

	TITLE	44/50L 400mil TSOP-2 Package Outline	REV.	E	DATE	03/19/2009
--	-------	---	------	---	------	------------

Компания «Life Electronics» занимается поставками электронных компонентов импортного и отечественного производства от производителей и со складов крупных дистрибьюторов Европы, Америки и Азии.

С конца 2013 года компания активно расширяет линейку поставок компонентов по направлению коаксиальный кабель, кварцевые генераторы и конденсаторы (керамические, пленочные, электролитические), за счёт заключения дистрибьюторских договоров

Мы предлагаем:

- Конкурентоспособные цены и скидки постоянным клиентам.
- Специальные условия для постоянных клиентов.
- Подбор аналогов.
- Поставку компонентов в любых объемах, удовлетворяющих вашим потребностям.
- Приемлемые сроки поставки, возможна ускоренная поставка.
- Доставку товара в любую точку России и стран СНГ.
- Комплексную поставку.
- Работу по проектам и поставку образцов.
- Формирование склада под заказчика.
- Сертификаты соответствия на поставляемую продукцию (по желанию клиента).
- Тестирование поставляемой продукции.
- Поставку компонентов, требующих военную и космическую приемку.
- Входной контроль качества.
- Наличие сертификата ISO.

В составе нашей компании организован Конструкторский отдел, призванный помогать разработчикам, и инженерам.

Конструкторский отдел помогает осуществить:

- Регистрацию проекта у производителя компонентов.
- Техническую поддержку проекта.
- Защиту от снятия компонента с производства.
- Оценку стоимости проекта по компонентам.
- Изготовление тестовой платы монтаж и пусконаладочные работы.



Тел: +7 (812) 336 43 04 (многоканальный)  
Email: [org@lifeelectronics.ru](mailto:org@lifeelectronics.ru)