



The Infinite Bandwidth Company™

# MIC59P60

## 8-Bit Serial-Input Protected Latched Driver

### General Description

The MIC59P60 serial-input latched driver is a high-voltage (80V), high-current (500mA) integrated circuit comprised of eight CMOS data latches, a bipolar Darlington transistor driver for each latch, and CMOS control circuitry for the common CLEAR, STROBE, CLOCK, SERIAL DATA INPUT, and OUTPUT ENABLE functions. Similar to the MIC5842, additional protection circuitry supplied on this device includes thermal shutdown, under voltage lockout (UVLO), and over-current shutdown.

The bipolar/CMOS combination provides an extremely low-power latch with maximum interface flexibility. The MIC59P60 has open-collector outputs capable of sinking 500mA and integral diodes for inductive load transient suppression with a minimum output breakdown voltage rating of 80V (50V sustaining). The drivers can be operated with a split supply, where the negative supply is down to -20V and may be paralleled for higher load current capability.

Using a 5V logic supply, the MIC59P60 will typically operate at better than 5MHz. With a 12V logic supply, significantly higher speeds are obtained. The CMOS inputs are compatible with standard CMOS, PMOS, and NMOS circuits. TTL circuits may require pull-up resistors. By using the serial data output, drivers may be cascaded for interface applications requiring additional drive lines.

Each of these eight outputs has an independent over current shutdown of 500 mA. Upon over-current shutdown, the affected channel will turn OFF and the flag will go low until  $V_{DD}$  is cycled or the ENABLE/RESET pin is pulsed high. Current pulses less than 2µs will not activate current shutdown. Temperatures above 165°C will shut down the device and activate the error flag. The UVLO circuit prevents operation at low  $V_{DD}$ ; hysteresis of 0.5V is provided.

### Features

- 3.3 MHz Minimum Data-Input Rate
- Output Current Shutdown (500mA Typical)
- Under Voltage Lockout
- Thermal Shutdown
- Output Fault Flag
- CMOS, PMOS, NMOS, and TTL Compatible
- Internal Pull-Up/Pull-Down Resistors
- Low Power CMOS Logic and Latches
- High Voltage Current Sink Outputs
- Output Transient-Protection Diodes
- Single or Split Supply Operation

### Ordering Information

Part Number	Temperature Range	Package
MIC59P60BN	-40°C to +85°C	20-Pin Plastic DIP
MIC59P60BV	-40°C to +85°C	20-Pin PLCC
MIC59P60BWM	-40°C to +85°C	20-Pin Wide SOIC

### Functional Diagram

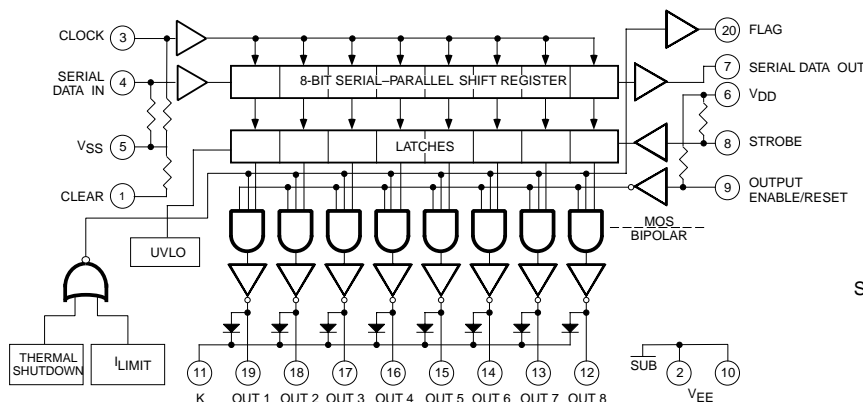

### Pin Configuration

(DIP and SOIC)

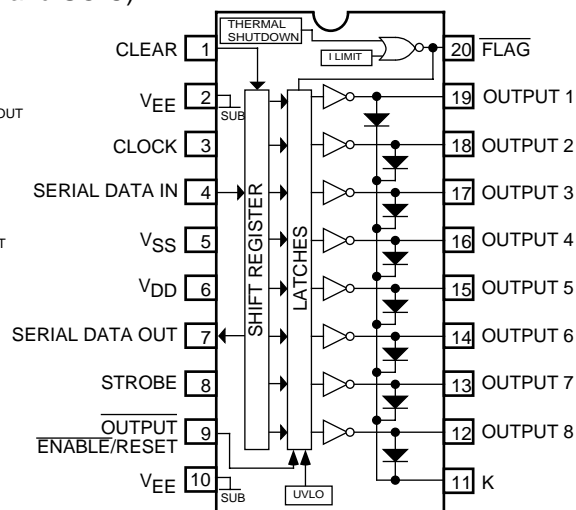

**PLCC Pin Configuration**

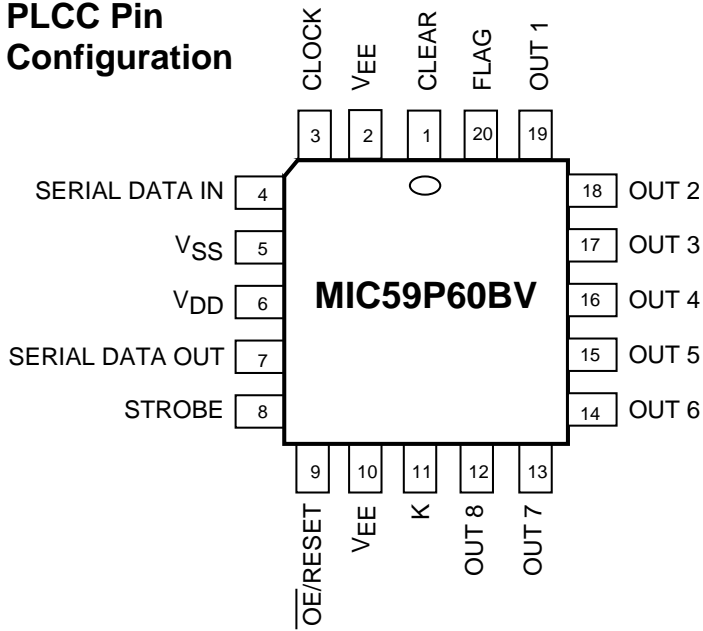

**Typical Inputs**

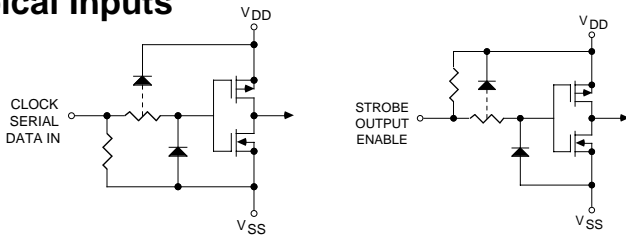

**Typical Output Driver**

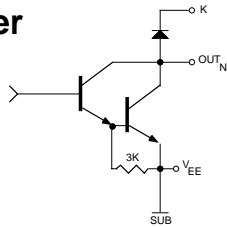

**Pin Description**

Pin	Name	Description
1	CLEAR	Sets All Latches OFF (open).
2,10	V <sub>EE</sub>	Output Ground (Substrate). Most negative voltage in the system connects here.
3	CLOCK	Serial Data Clock. A CLEAR must also be clocked into the latches.
4	SERIAL DATA IN	Serial Data Input pin.
5	V <sub>SS</sub>	Logic reference (Ground) pin.
6	V <sub>DD</sub>	Logic Positive Supply voltage.
7	SERIAL DATA OUT	Serial Data Output pin. (Flow through).
8	STROBE	Output Strobe pin. Loads output latches when High. A STROBE is needed to CLEAR latches.
9	OUTPUT ENABLE/RESET	When Low, Outputs are active. When High, device is inactive and reset from a fault condition. An under voltage condition emulates a high OE/RESET input.
11	K	Transient suppression diode's cathode common pin.
12—19	OUTPUT N	Open Collector outputs 8 through 1.
20	FLAG	Error Flag. Open-collector output is Low upon Overcurrent Fault or Overtemperature fault. OUTPUT ENABLE/RESET must be pulled high to reset the flag and fault condition.

**Absolute Maximum Ratings** V<sub>SS</sub> = 0; T<sub>A</sub> = 25°C

Output Voltage (V <sub>CE</sub> )	80V
Output Voltage (V <sub>CE(SUS)</sub> )	50V, <b>Note 1</b>
V <sub>DD</sub> with Reference to V <sub>SS</sub>	15V
V <sub>DD</sub> with Reference to V <sub>EE</sub>	25V
Emitter Supply Voltage (V <sub>EE</sub> )	-20V
Input Voltage (V <sub>IN</sub> )	-0.3V to V <sub>DD</sub> +0.3V
Protected Current	1.5A, <b>Note 2</b>
Power Dissipation (P <sub>D</sub> )	
Plastic DIP (N)	2.0W
Derate above T <sub>A</sub> = +25°C	20mW/°C
PLCC (V)	1.4W
Derate above T <sub>A</sub> = +25°C	14mW/°C
Wide SOIC (WM)	1.2W
Derate above T <sub>A</sub> = +25°C	12mW/°C
Operating Temperature (T <sub>A</sub> )	
Plastic DIP (N), PLCC (V), SOIC (WM)	-40°C to +85°C
Storage Temperature (T <sub>S</sub> )	-65°C to +150°C
Junction Temperature (T <sub>J</sub> )	+150°C
ESD	<b>Note 3</b>

**Note 1:** For inductive load applications.

**Note 2:** Each channel. V<sub>EE</sub> connection must be designed to minimize inductance and resistance.

**Note 3:** Devices are input-static protected but can be damaged by extremely high static charges.

## Electrical Characteristics

$V_{DD} = 5V$ ,  $V_{SS} = V_{EE} = 0V$ ;  $T_A = +25^\circ C$ ; unless noted.

Characteristic	Symbol	Test Conditions	Limits			Unit
			Min.	Typ.	Max.	
Output Leakage Current	$I_{CEX}$	$V_{OUT} = 80V$ $V_{OUT} = 80V, T_A = +70^\circ C$		100	50	$\mu A$
Collector-Emitter Saturation Voltage	$V_{CE(SAT)}$	$I_{OUT} = 100mA$ $I_{OUT} = 200mA$ $I_{OUT} = 350mA$		0.9 1.1 1.3	1.1 1.3 1.6	V
Collector-Emitter Sustaining Voltage	$V_{CE(SUS)}$	$I_{OUT} = 350mA, L = 2mH$	50			V
Input Voltage	$V_{IN(0)}$				1.0	V
	$V_{IN(1)}$	$V_{DD} = 12V$ $V_{DD} = 10V$ $V_{DD} = 5.0V, \text{Note 4}$	10.5 8.5 3.5			V
Input Resistance	$R_{IN}$	$V_{DD} = 12V$	50	200		$k\Omega$
		$V_{DD} = 10V$	50	300		
		$V_{DD} = 5.0V$	50	600		
Flag Output Current	$I_{OL}$	$V_{OL} = 0.4V$		15		mA
Flag Output Leakage	$I_{OH}$	$V_{OH} = 12.0V$		50		nA
Supply Current	$I_{DD(ON)}$	All Drivers ON, $V_{DD} = 12V$		6.4	10.0	mA
		All Drivers ON, $V_{DD} = 10V$		6.0	9.0	
		All Drivers ON, $V_{DD} = 5.0V$		4.6	7.5	
	$I_{DD(1 OUTPUT)}$	One Driver ON, All others OFF, $V_{DD} = 12V$		3.1	4.5	mA
		One Driver ON, All others OFF, $V_{DD} = 10V$		2.9	4.5	
		One Driver ON, All others OFF, $V_{DD} = 5V$		2.3	3.6	
	$I_{DD(OFF)}$	All Drivers OFF, $V_{DD} = 12V$		2.6	4.2	mA
		All Drivers OFF, $V_{DD} = 10V$		2.4	3.6	
		All Drivers OFF, $V_{DD} = 5.0V$		1.9	3.0	
Clamp Diode Leakage Current	$I_R$	$V_R = 80V$			50	$\mu A$
Clamp Diode Forward Voltage	$V_F$	$I_F = 350mA$		1.7	2.0	V
Over Current Shutdown Threshold	$I_{LIM}$			500		mA
Start Up Voltage	$V_{SU}$	<b>Note 5</b>	3.5	4.0	4.5	V
Minimum Supply ( $V_{DD}$ )	$V_{DD MIN}$		3.0	3.5	4.0	V
Thermal Shutdown				165		$^\circ C$
Thermal Shutdown Hysteresis				10		$^\circ C$

**Note 4:** Operation of these devices with standard TTL or DTL may require the use of appropriate pull-up resistors to insure a minimum logic "1".

**Note 5:** Undervoltage lockout is guaranteed to release device at no more than 4.5V, and disable the device at no less than 3.0V



# Typical Characteristic Curves

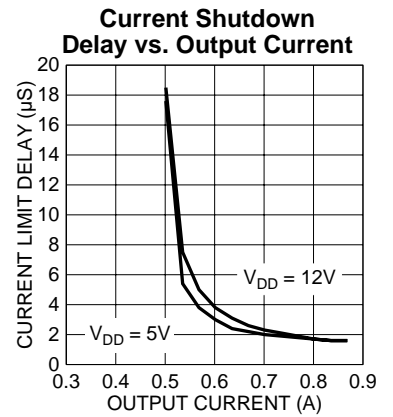
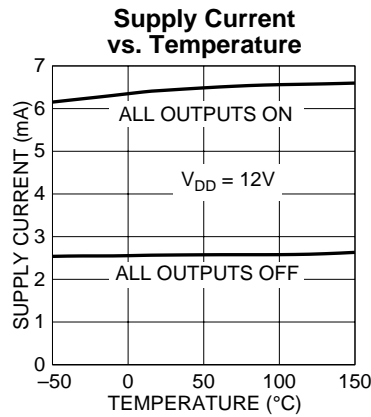
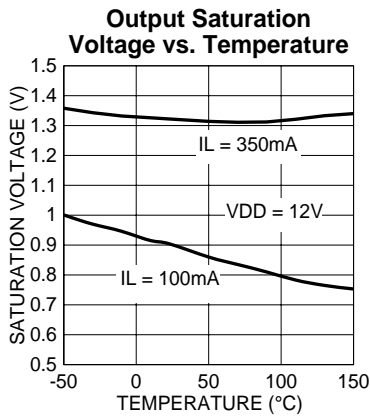
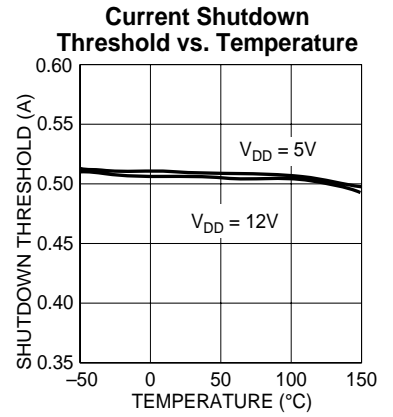
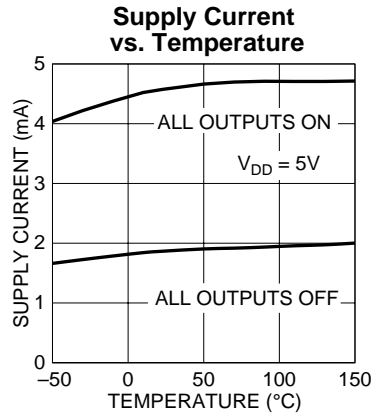
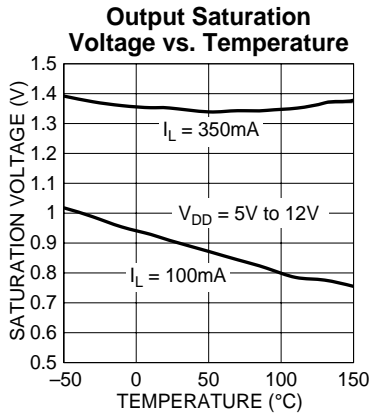

### Maximum Allowable Duty Cycle (Plastic DIP)

V<sub>DD</sub> = 5.0V

Number of Outputs ON (I <sub>OUT</sub> = 200mA V <sub>DD</sub> = 5.0V)	Max. Allowable Duty Cycle at Ambient Temperature of				
	25°C	40°C	50°C	60°C	70°C
8	85%	72%	64%	55%	46%
7	97%	82%	73%	63%	53%
6	100%	96%	85%	73%	62%
5	100%	100%	100%	88%	75%
4	100%	100%	100%	100%	93%
3	100%	100%	100%	100%	100%
2	100%	100%	100%	100%	100%
1	100%	100%	100%	100%	100%

V<sub>DD</sub> = 12V

Number of Outputs ON (I <sub>OUT</sub> = 200mA V <sub>DD</sub> = 12V)	Max. Allowable Duty Cycle at Ambient Temperature of				
	25°C	40°C	50°C	60°C	70°C
8	80%	68%	60%	52%	44%
7	91%	77%	68%	59%	50%
6	100%	90%	79%	69%	58%
5	100%	100%	95%	82%	69%
4	100%	100%	100%	100%	86%
3	100%	100%	100%	100%	100%
2	100%	100%	100%	100%	100%
1	100%	100%	100%	100%	100%

### Typical Applications

Protected Solenoid Driver with Output Enable

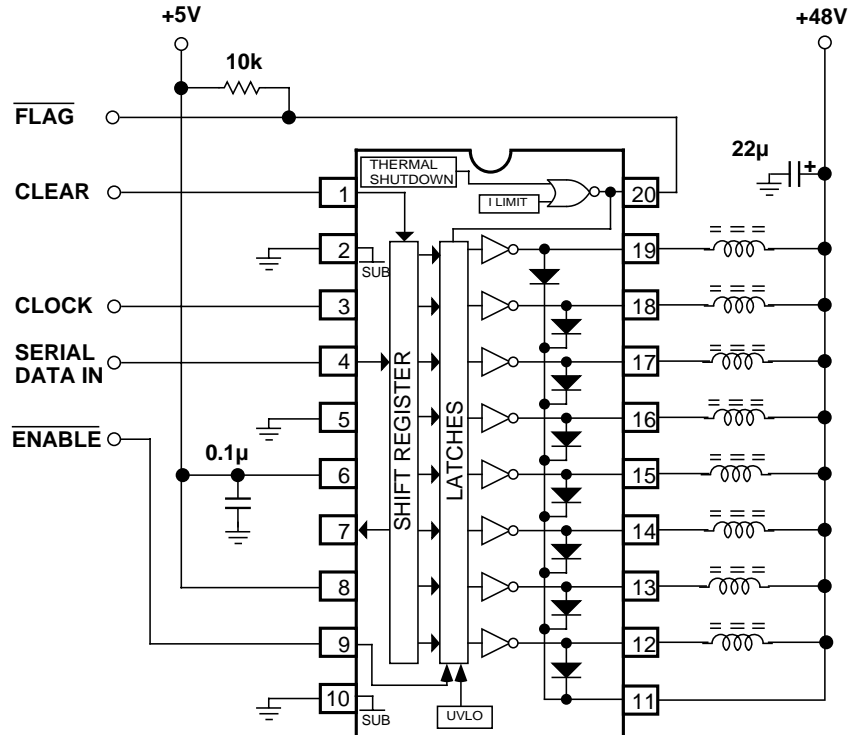

### Hammer Driver

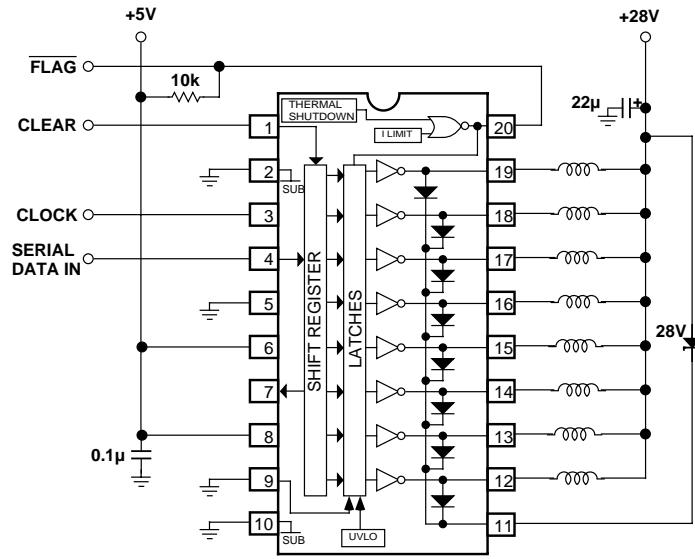

### Protected Negative/Positive PIN Diode Driver Transmit/Receive Switch

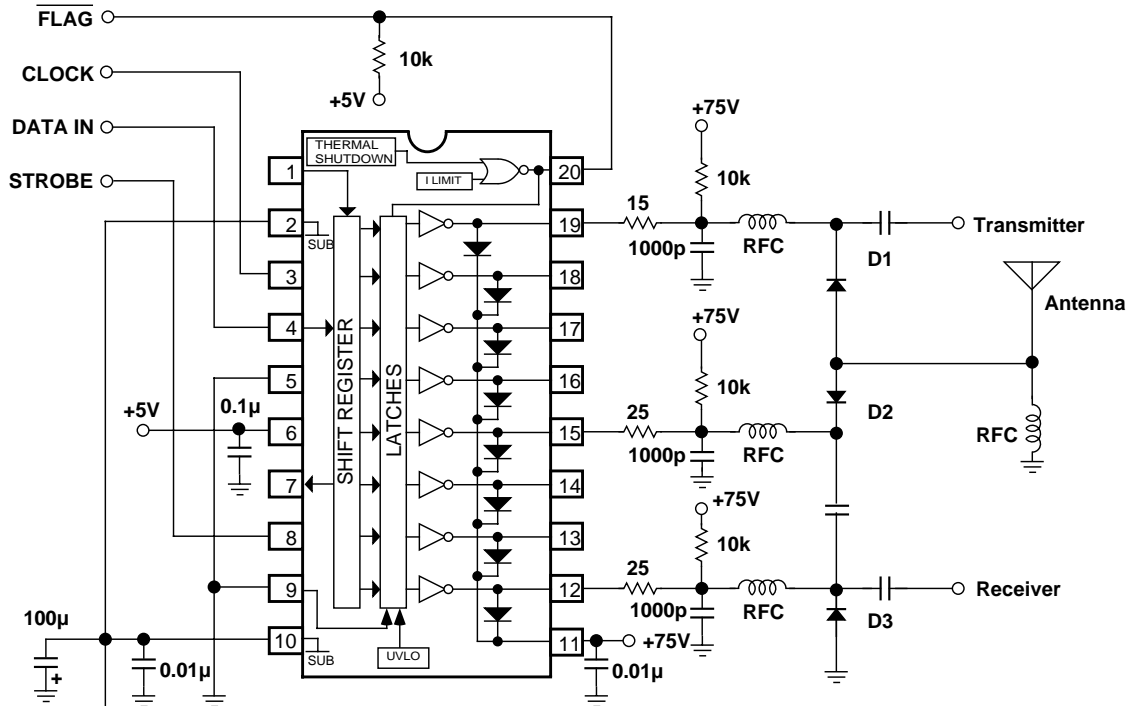

	D1 (Latch 1)	Diode D2 (Latch 5)	D3 (Latch 8)
Receive	OFF	ACTIVE	OFF
Transmit	ACTIVE	OFF	ACTIVE

PIN Diodes: UM9651

Package Information

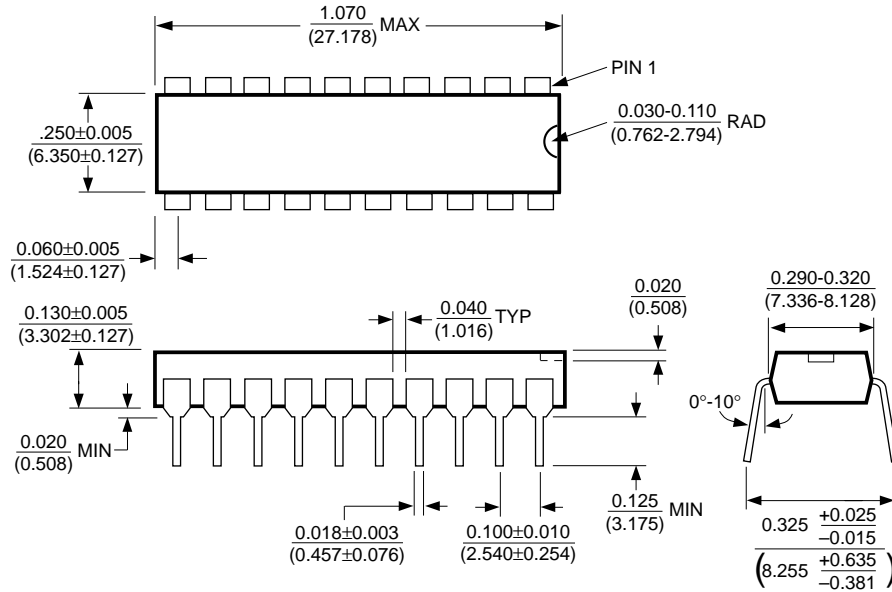

20-Pin Plastic DIP (N)

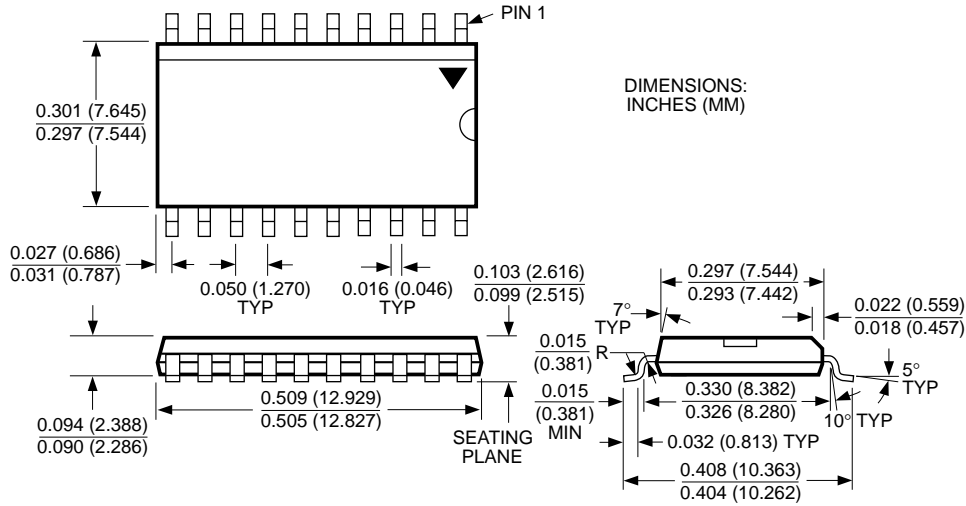

20-Pin Wide SOP (WM)



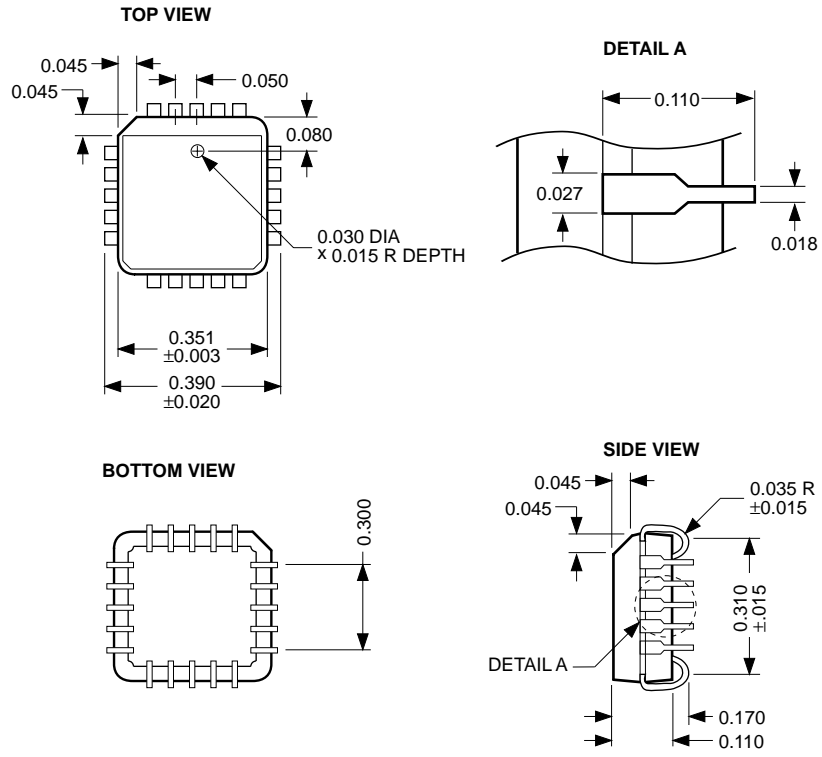

20-Pin PLCC (V)





---

**MICREL INC. 1849 FORTUNE DRIVE SAN JOSE, CA 95131 USA**

TEL + 1 (408) 944-0800 FAX + 1 (408) 944-0970 WEB <http://www.micrel.com>

This information is believed to be accurate and reliable, however no responsibility is assumed by Micrel for its use nor for any infringement of patents or other rights of third parties resulting from its use. No license is granted by implication or otherwise under any patent or patent right of Micrel Inc.

© 2001 Micrel Incorporated

Компания «Life Electronics» занимается поставками электронных компонентов импортного и отечественного производства от производителей и со складов крупных дистрибьюторов Европы, Америки и Азии.

С конца 2013 года компания активно расширяет линейку поставок компонентов по направлению коаксиальный кабель, кварцевые генераторы и конденсаторы (керамические, пленочные, электролитические), за счёт заключения дистрибьюторских договоров

Мы предлагаем:

- Конкуренспособные цены и скидки постоянным клиентам.
- Специальные условия для постоянных клиентов.
- Подбор аналогов.
- Поставку компонентов в любых объемах, удовлетворяющих вашим потребностям.
- Приемлемые сроки поставки, возможна ускоренная поставка.
- Доставку товара в любую точку России и стран СНГ.
- Комплексную поставку.
- Работу по проектам и поставку образцов.
- Формирование склада под заказчика.
- Сертификаты соответствия на поставляемую продукцию (по желанию клиента).
- Тестирование поставляемой продукции.
- Поставку компонентов, требующих военную и космическую приемку.
- Входной контроль качества.
- Наличие сертификата ISO.

В составе нашей компании организован Конструкторский отдел, призванный помогать разработчикам, и инженерам.

Конструкторский отдел помогает осуществить:

- Регистрацию проекта у производителя компонентов.
- Техническую поддержку проекта.
- Защиту от снятия компонента с производства.
- Оценку стоимости проекта по компонентам.
- Изготовление тестовой платы монтаж и пусконаладочные работы.



Тел: +7 (812) 336 43 04 (многоканальный)

Email: [org@lifeelectronics.ru](mailto:org@lifeelectronics.ru)