



STB11NM80, STF11NM80 STI11NM80, STP11NM80, STW11NM80

N-channel 800 V, 0.35 Ω , 11 A MDmesh™ Power MOSFET
in D²PAK, TO-220FP, I²PAK, TO-220, TO-247

Features

Order codes	V _{DSS}	R _{DS(on) max}	R _{DS(on)} *Q _g	I _D
STB11NM80	800 V	< 0.40 Ω	14 Ω *nC	11 A
STF11NM80				
STI11NM80				
STP11NM80				
STW11NM80				

- Low input capacitance and gate charge
- Low gate input resistance
- Best R_{DS(on)}*Q_g in the industry

Applications

- Switching applications

Description

These N-channel Power MOSFETs are developed using STMicroelectronics' revolutionary MDmesh™ technology, which associates the multiple drain process with the company's PowerMESH™ horizontal layout. These devices offer extremely low on-resistance, high dv/dt and excellent avalanche characteristics. Utilizing ST's proprietary strip technique, these Power MOSFETs boast an overall dynamic performance which is superior to similar products on the market.

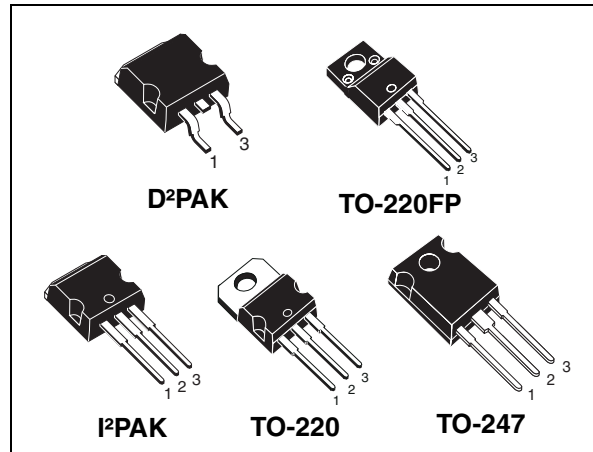

Figure 1. Internal schematic diagram

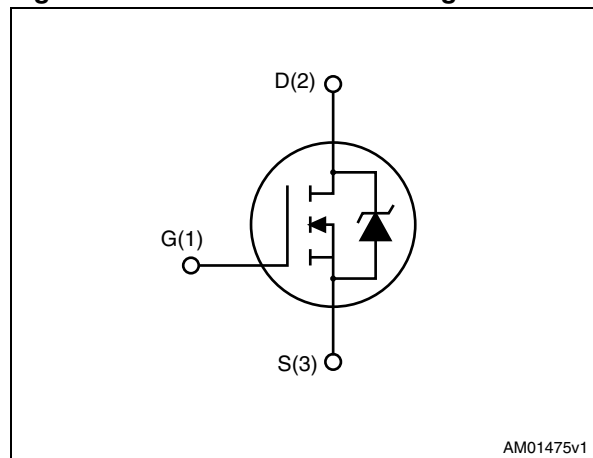

Table 1. Device summary

Order codes	Marking	Package	Packaging
STB11NM80	B11NM80	D ² PAK	Tape and reel
STF11NM80	F11NM80	TO-220FP	Tube
STI11NM80	I11NM80	I ² PAK	
STP11NM80	P11NM80	TO-220	
STW11NM80	W11NM80	TO-247	

Contents

1	Electrical ratings	3
2	Electrical characteristics	4
2.1	Electrical characteristics (curves)	6
3	Test circuits	9
4	Package mechanical data	10
5	Packaging mechanical data	19
6	Revision history	21

1 Electrical ratings

Table 2. Absolute maximum ratings

Symbol	Parameter	Value		Unit
		D ² PAK, I ² PAK TO-220, TO-247	TO-220FP	
V _{DS}	Drain-source voltage (V _{GS} = 0)	800		V
V _{GS}	Gate-source voltage	±30		V
I _D	Drain current (continuous) at T _C = 25 °C	11	11 ⁽¹⁾	A
I _D	Drain current (continuous) at T _C =100 °C	8	8 ⁽¹⁾	A
I _{DM} ⁽²⁾	Drain current (pulsed)	44	44 ⁽¹⁾	A
P _{TOT}	Total dissipation at T _C = 25 °C	150	35	W
	Derating factor	1.2	0.28	W/°C
V _{ISO}	Insulation withstand voltage (DC)		2500	V
T _J T _{stg}	Operating junction temperature Storage temperature	-65 to 150		°C

- Limited only by the maximum temperature allowed
- Pulse width limited by safe operating area

Table 3. Thermal data

Symbol	Parameter	Value					Unit
		D ² PAK	TO-220FP	I ² PAK	TO-220	TO-247	
R _{thj-case}	Thermal resistance junction-case max	0.83	3.6	0.83		°C/W	
R _{thj-a}	Thermal resistance junction-ambient max		62.5		50	°C/W	
R _{thj-pcb} ⁽¹⁾	Thermal resistance junction-pcb max	30				°C/W	
T _l	Maximum lead temperature for soldering purpose		300			°C	

- When mounted on 1inch² FR-4 board, 2 oz Cu

Table 4. Avalanche characteristics

Symbol	Parameter	Value	Unit
I _{AS}	Avalanche current, repetitive or not-repetitive (pulse width limited by T _J max)	2.5	A
E _{AS}	Single pulse avalanche energy (starting T _J = 25 °C, I _D = I _{AR} , V _{DD} = 50 V)	400	mJ

2 Electrical characteristics

($T_{CASE} = 25\text{ °C}$ unless otherwise specified)

Table 5. On/off states

Symbol	Parameter	Test conditions	Min.	Typ.	Max.	Unit
$V_{(BR)DSS}$	Drain-source breakdown voltage ($V_{GS} = 0$)	$I_D = 250\ \mu A$	800			V
$dv/dt^{(1)}$	Drain source voltage slope	$V_{DD} = 640\text{ V}$, $I_D = 11\text{ A}$, $V_{GS} = 10\text{ V}$	30			V/ns
I_{DSS}	Zero gate voltage drain current ($V_{GS} = 0$)	$V_{DS} = 800\text{ V}$, $V_{DS} = 800\text{ V @ }125\text{ °C}$			10 100	μA μA
I_{GSS}	Gate body leakage current ($V_{DS} = 0$)	$V_{GS} = \pm 30\text{ V}$			100	nA
$V_{GS(th)}$	Gate threshold voltage	$V_{DS} = V_{GS}$, $I_D = 250\ \mu A$	3	4	5	V
$R_{DS(on)}$	Static drain-source on resistance	$V_{GS} = 10\text{ V}$, $I_D = 5.5\text{ A}$		0.35	0.40	Ω

1. Characteristic value at turn off on inductive load

Table 6. Dynamic

Symbol	Parameter	Test conditions	Min.	Typ.	Max.	Unit
$g_{fs}^{(1)}$	Forward transconductance	$V_{DS} > I_{D(on)} \times R_{DS(on)max}$, $I_D = 7.5\text{ A}$	-	8	-	S
C_{iss} C_{oss} C_{rss}	Input capacitance Output capacitance Reverse transfer capacitance	$V_{DS} = 25\text{ V}$, $f = 1\text{ MHz}$, $V_{GS} = 0$	-	1630 750 30	-	pF pF pF
Q_g Q_{gs} Q_{gd}	Total gate charge Gate-source charge Gate-drain charge	$V_{DD} = 640\text{ V}$, $I_D = 11\text{ A}$ $V_{GS} = 10\text{ V}$ (see Figure 18)	-	43.6 11.6 21	-	nC nC nC
R_g	Gate input resistance	$f = 1\text{ MHz}$ Gate DC Bias = 0 Test signal level = 20 mV open drain	-	2.7	-	Ω
$t_{d(on)}$ t_r $t_{d(off)}$ t_f	Turn-on delay time Rise time Turn-off delay time Fall time	$V_{DD} = 400\text{ V}$, $I_D = 5.5\text{ A}$, $R_G = 4.7\ \Omega$, $V_{GS} = 10\text{ V}$ (see Figure 17)	-	22 17 46 15	-	ns ns ns ns

1. Pulsed: pulse duration = 300 μs , duty cycle 1.5%

Table 7. Source drain diode

Symbol	Parameter	Test conditions	Min.	Typ.	Max.	Unit
I_{SD}	Source-drain current		-		11	A
$I_{SDM}^{(1)}$	Source-drain current (pulsed)		-		44	A
$V_{SD}^{(2)}$	Forward on voltage	$I_{SD}=11\text{ A}$, $V_{GS}=0$	-		0.86	V
t_{rr}	Reverse recovery time	$I_{SD}=11\text{ A}$, $di/dt = 100\text{ A}/\mu\text{s}$, $V_{DD}= 50\text{ V}$	-	612		ns
Q_{rr}	Reverse recovery charge			7.22		μC
I_{RRM}	Reverse recovery current			23.6		A
t_{rr}	Reverse recovery time	$I_{SD}=11\text{ A}$, $di/dt = 100\text{ A}/\mu\text{s}$, $V_{DD}= 50\text{ V}$, $T_j=150\text{ }^\circ\text{C}$	-	970		ns
Q_{rr}	Reverse recovery charge			11.25		μC
I_{RRM}	Reverse recovery current			23.2		A

1. Pulse width limited by safe operating area
2. Pulsed: pulse duration=300 μs , duty cycle 1.5%

2.1 Electrical characteristics (curves)

Figure 2. Safe operating area for D²PAK, I²PAK, TO-220, TO-247

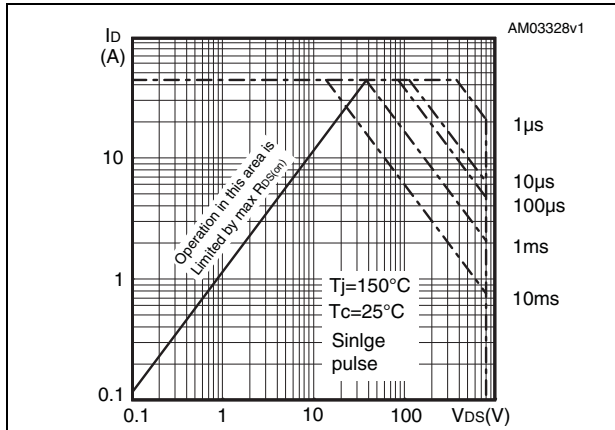

Figure 3. Thermal impedance for D²PAK, I²PAK, TO-220, TO-247

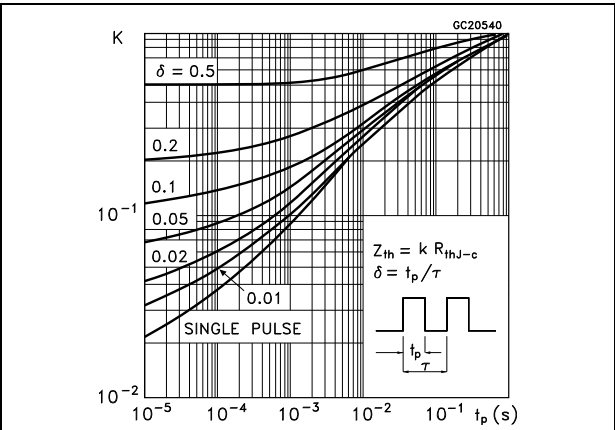

Figure 4. Safe operating area for TO-220FP

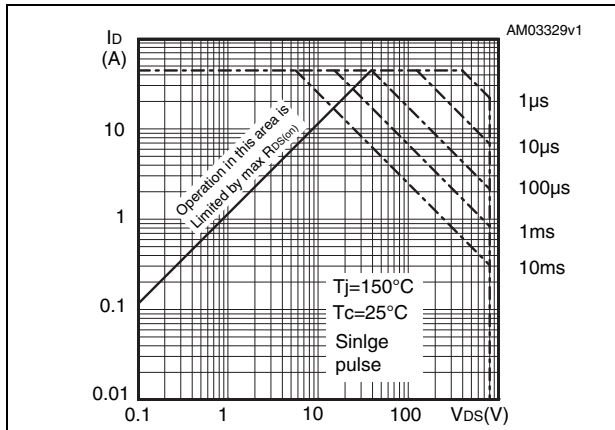

Figure 5. Thermal impedance for TO-220FP

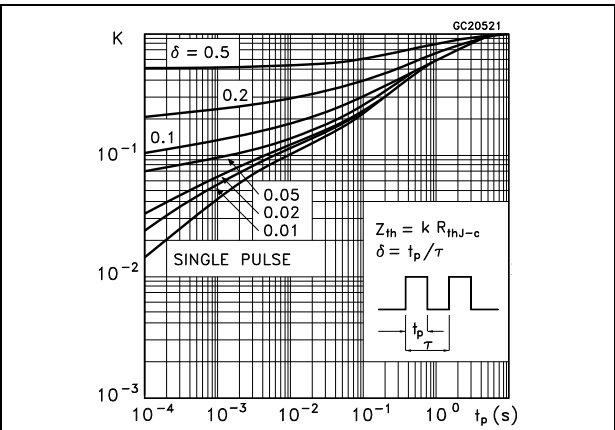

Figure 6. Output characteristics

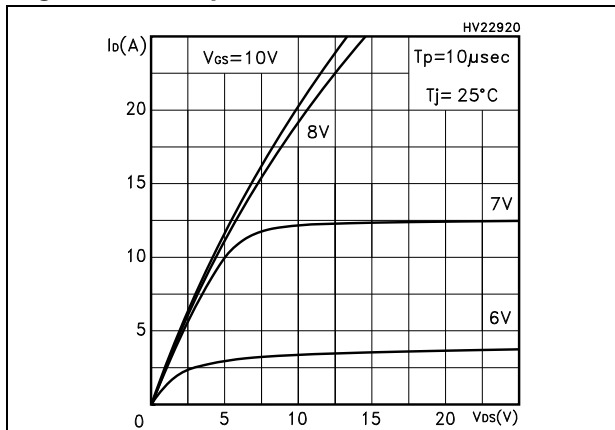

Figure 7. Output characteristics @ $T_j = 150^\circ\text{C}$

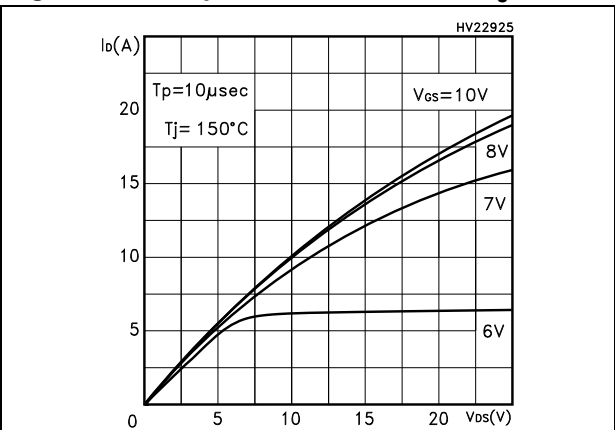

Figure 8. Transfer characteristics

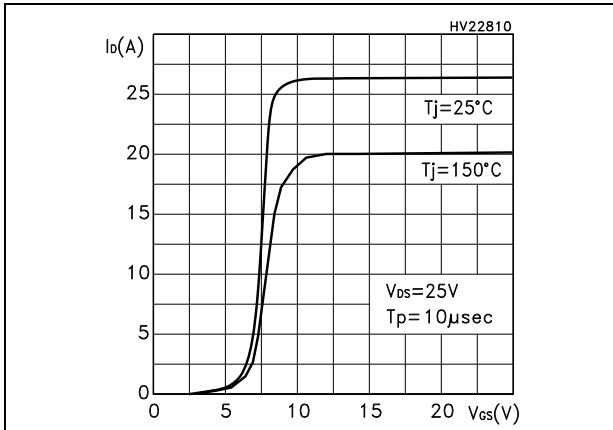

Figure 9. Transconductance

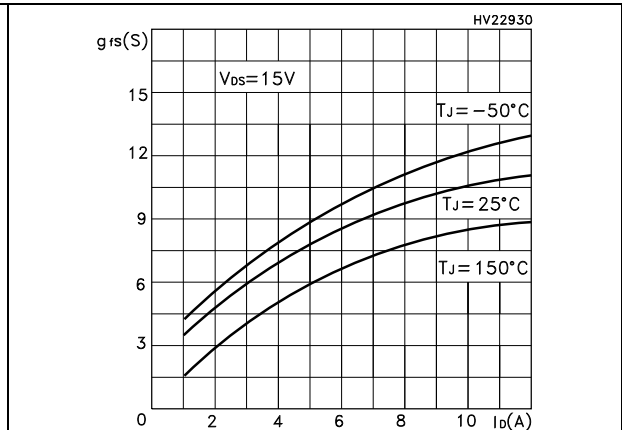

Figure 10. Gate charge vs gate-source voltage Figure 11. Capacitance variations

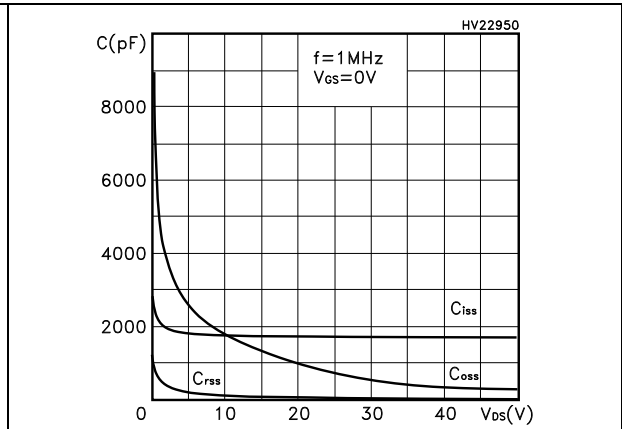
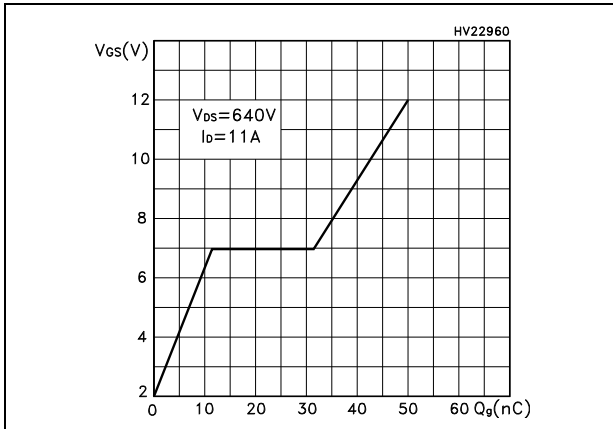

Figure 12. Normalized gate threshold voltage vs temperature

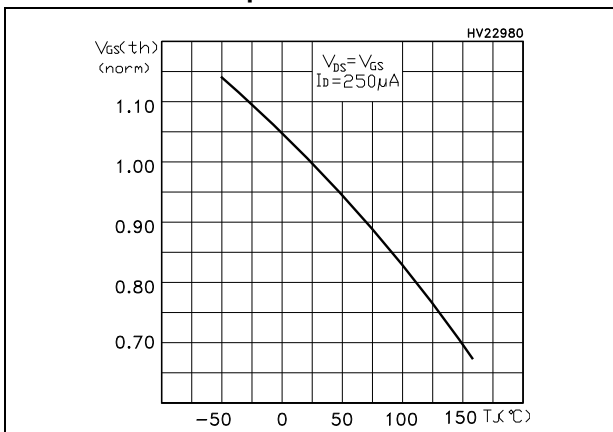

Figure 13. Static drain-source on resistance vs temperature

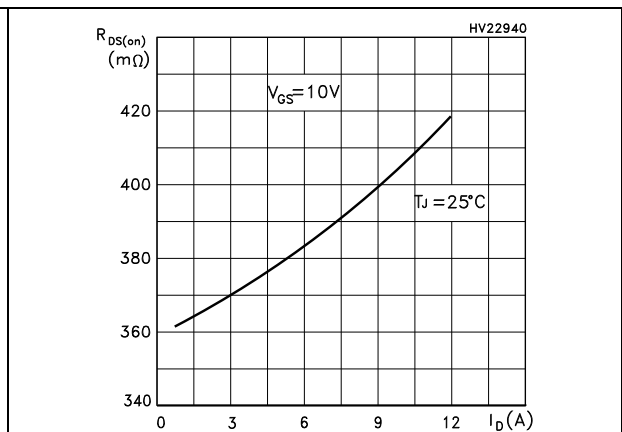

Figure 14. Source-drain diode forward characteristics

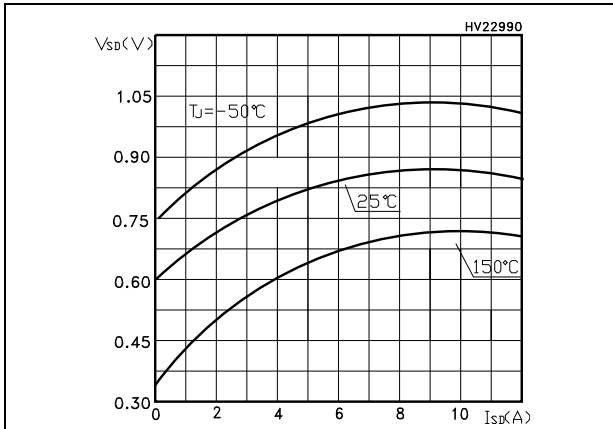

Figure 15. Normalized on resistance vs temperature

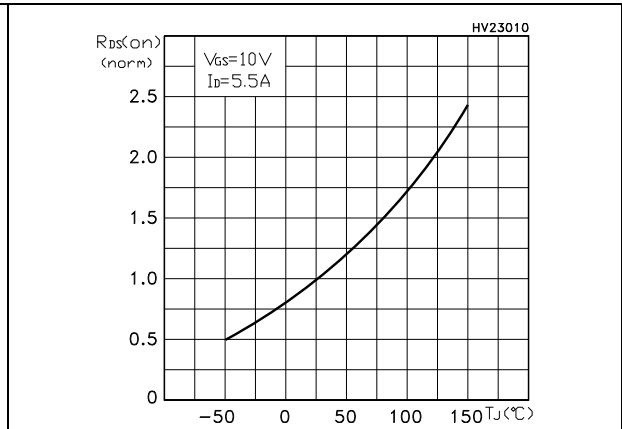
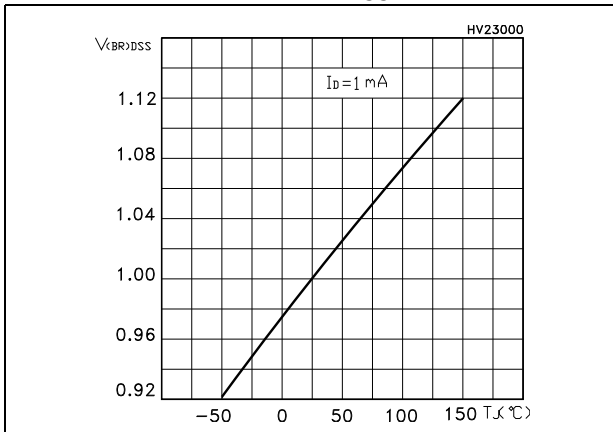

Figure 16. Normalized $B_{V_{DSS}}$ vs temperature



3 Test circuits

Figure 17. Switching times test circuit for resistive load

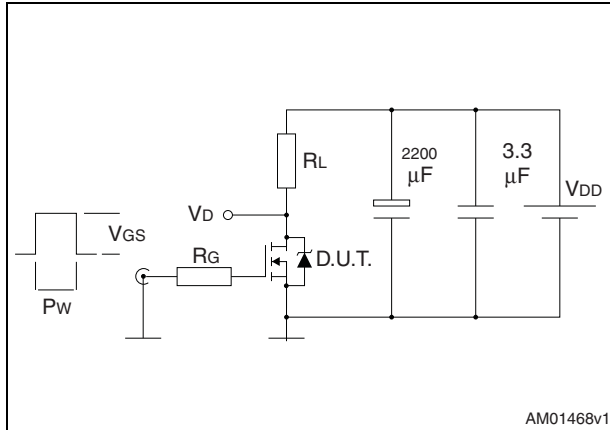

Figure 18. Gate charge test circuit

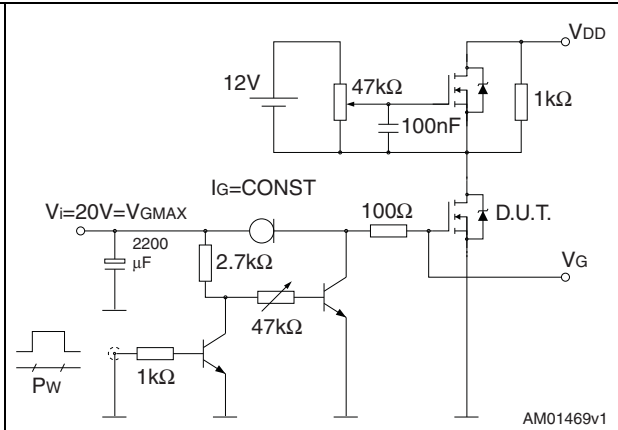

Figure 19. Test circuit for inductive load switching and diode recovery times

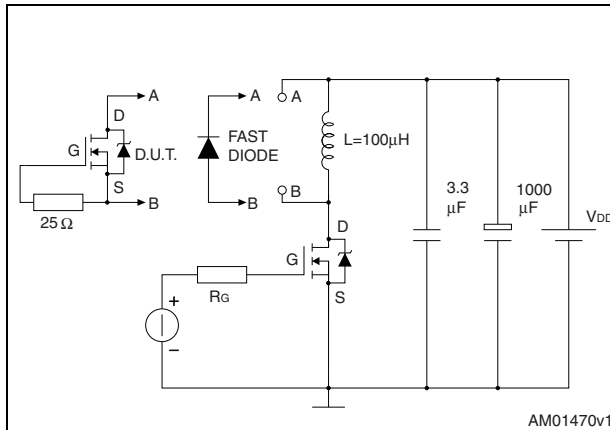

Figure 20. Unclamped inductive load test circuit

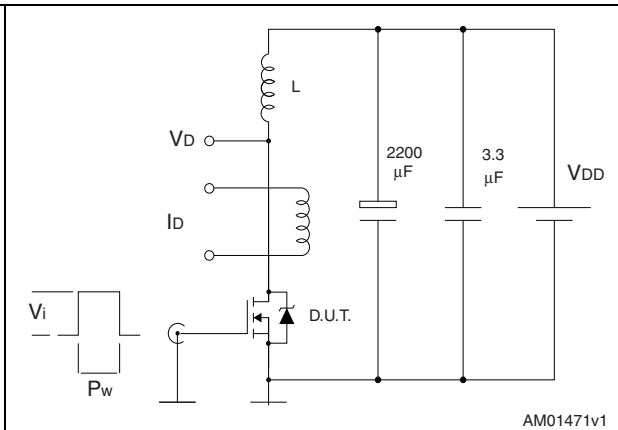

Figure 21. Unclamped inductive waveform

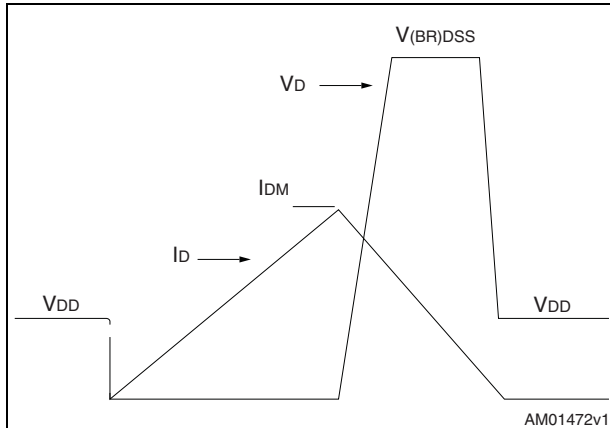
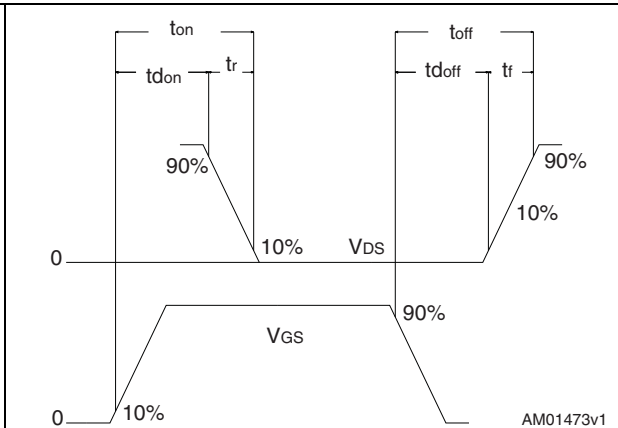

Figure 22. Switching time waveform



4 Package mechanical data

In order to meet environmental requirements, ST offers these devices in different grades of ECOPACK[®] packages, depending on their level of environmental compliance. ECOPACK[®] specifications, grade definitions and product status are available at: www.st.com. ECOPACK is an ST trademark.

Table 8. D²PAK (TO-263) mechanical data

Dim.	mm		
	Min.	Typ.	Max.
A	4.40		4.60
A1	0.03		0.23
b	0.70		0.93
b2	1.14		1.70
c	0.45		0.60
c2	1.23		1.36
D	8.95		9.35
D1	7.50		
E	10		10.40
E1	8.50		
e		2.54	
e1	4.88		5.28
H	15		15.85
J1	2.49		2.69
L	2.29		2.79
L1	1.27		1.40
L2	1.30		1.75
R		0.4	
V2	0°		8°

Figure 23. D²PAK (TO-263) drawing

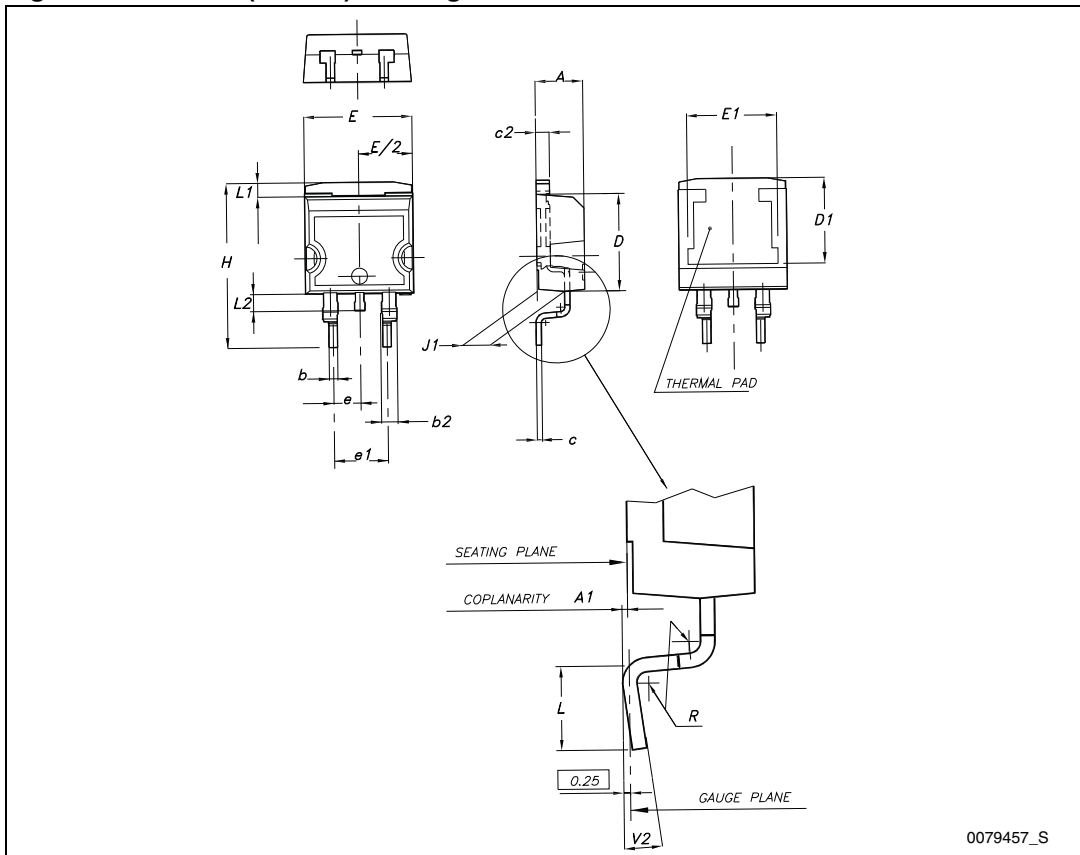
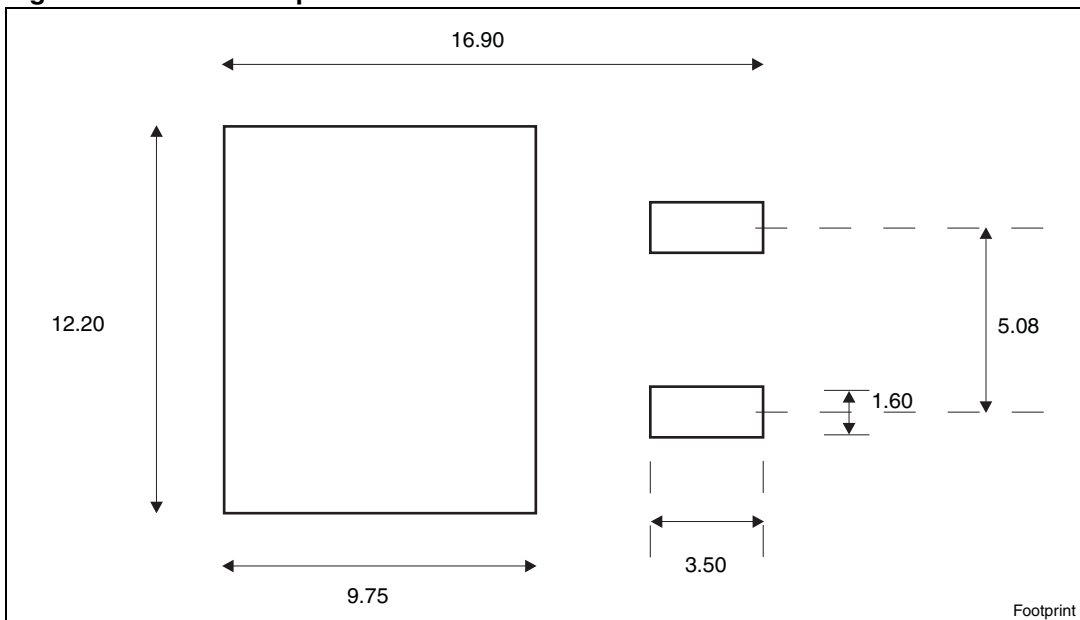

Figure 24. D²PAK footprint^(a)



a. All dimension are in millimeters

Table 9. TO-220FP mechanical data

Dim.	mm		
	Min.	Typ.	Max.
A	4.4		4.6
B	2.5		2.7
D	2.5		2.75
E	0.45		0.7
F	0.75		1
F1	1.15		1.70
F2	1.15		1.70
G	4.95		5.2
G1	2.4		2.7
H	10		10.4
L2		16	
L3	28.6		30.6
L4	9.8		10.6
L5	2.9		3.6
L6	15.9		16.4
L7	9		9.3
Dia	3		3.2

Figure 25. TO-220FP drawing

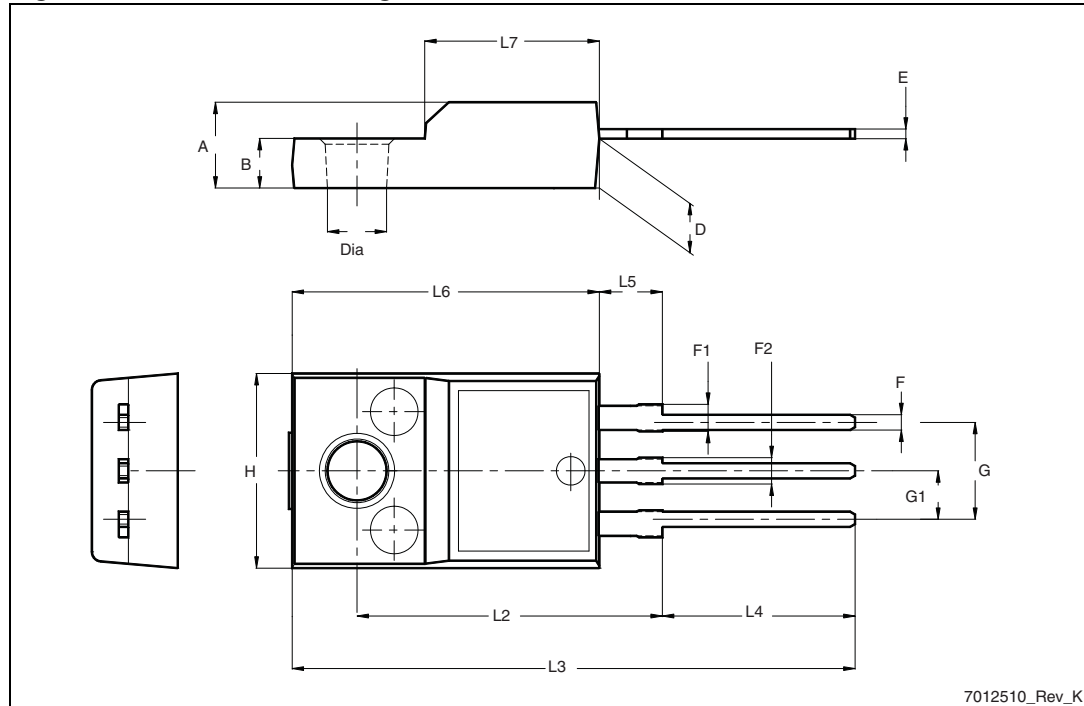
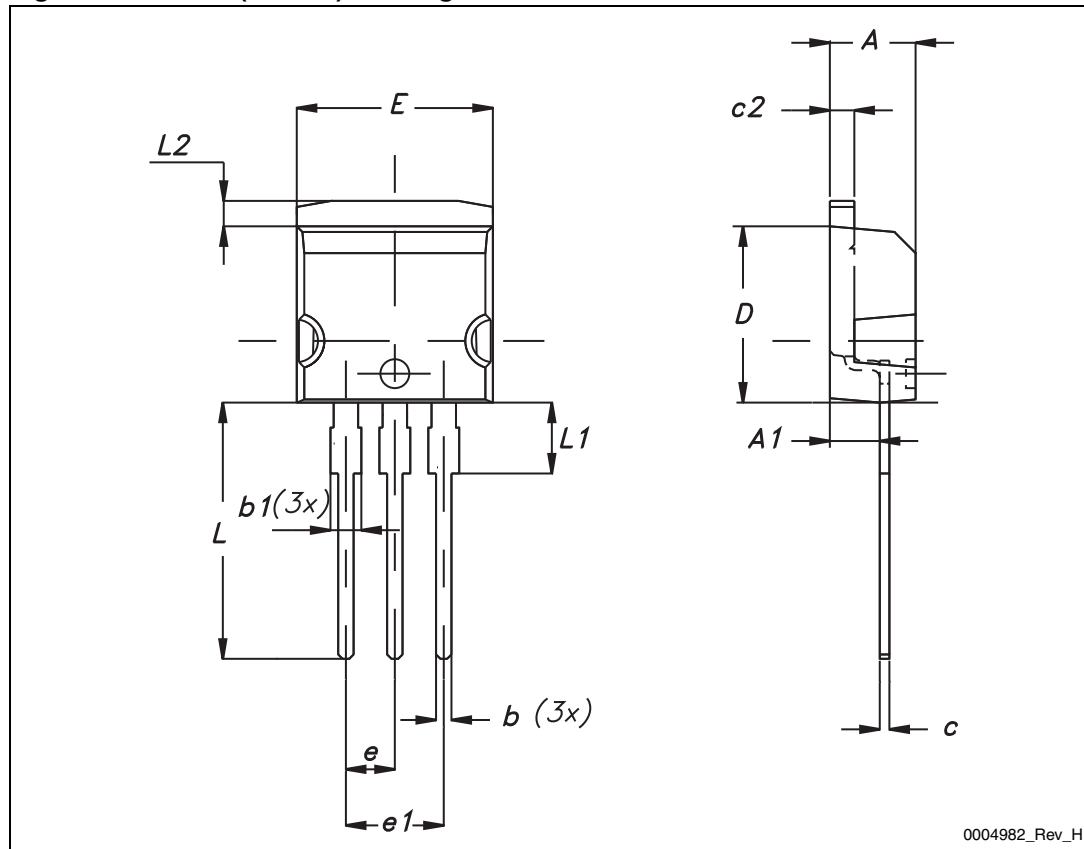

Table 10. I²PAK (TO-262) mechanical data

DIM.	mm.		
	min.	typ	max.
A	4.40		4.60
A1	2.40		2.72
b	0.61		0.88
b1	1.14		1.70
c	0.49		0.70
c2	1.23		1.32
D	8.95		9.35
e	2.40		2.70
e1	4.95		5.15
E	10		10.40
L	13		14
L1	3.50		3.93
L2	1.27		1.40

Figure 26. I²PAK (TO-262) drawing



0004982_Rev_H

Table 11. TO-220 type A mechanical data

Dim.	mm		
	Min.	Typ.	Max.
A	4.40		4.60
b	0.61		0.88
b1	1.14		1.70
c	0.48		0.70
D	15.25		15.75
D1		1.27	
E	10		10.40
e	2.40		2.70
e1	4.95		5.15
F	1.23		1.32
H1	6.20		6.60
J1	2.40		2.72
L	13		14
L1	3.50		3.93
L20		16.40	
L30		28.90	
ØP	3.75		3.85
Q	2.65		2.95

Figure 27. TO-220 type A drawing

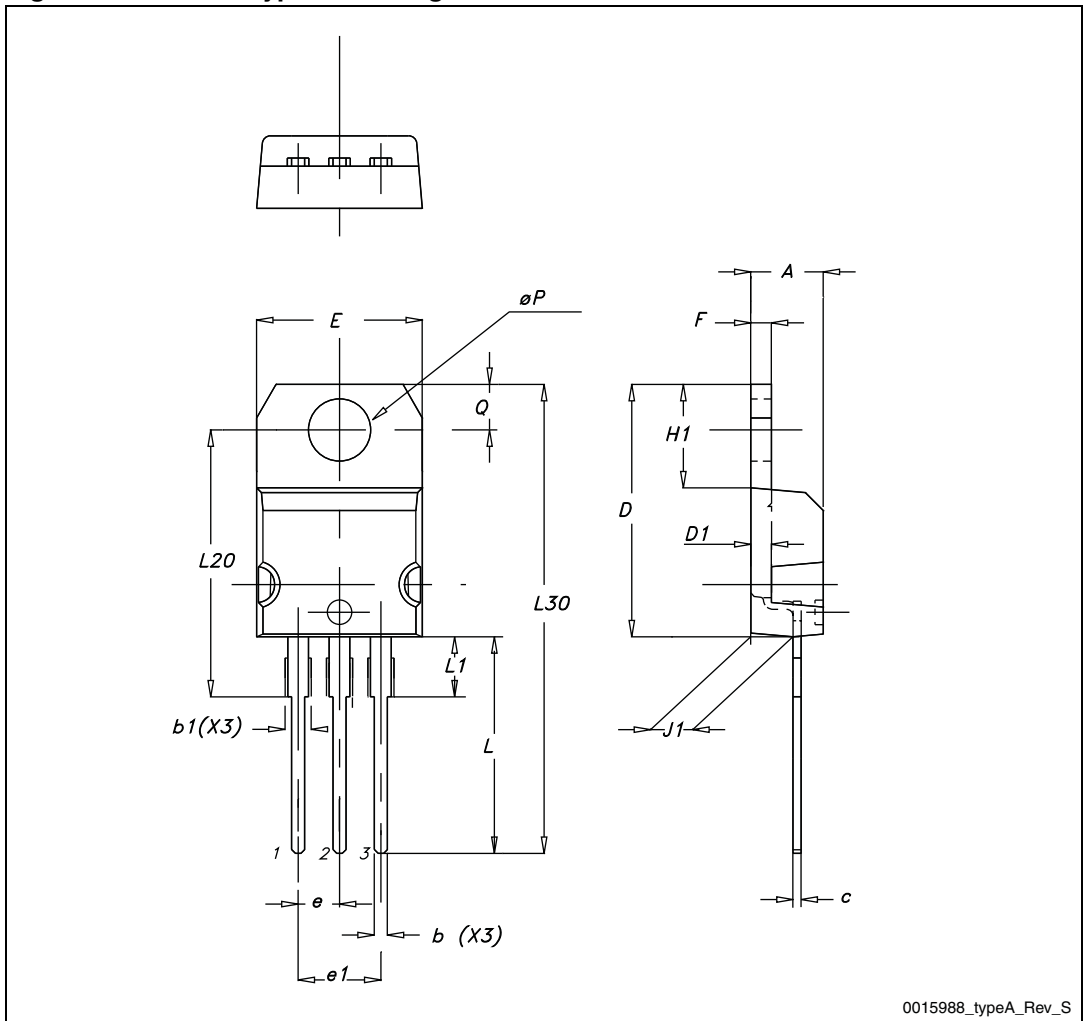
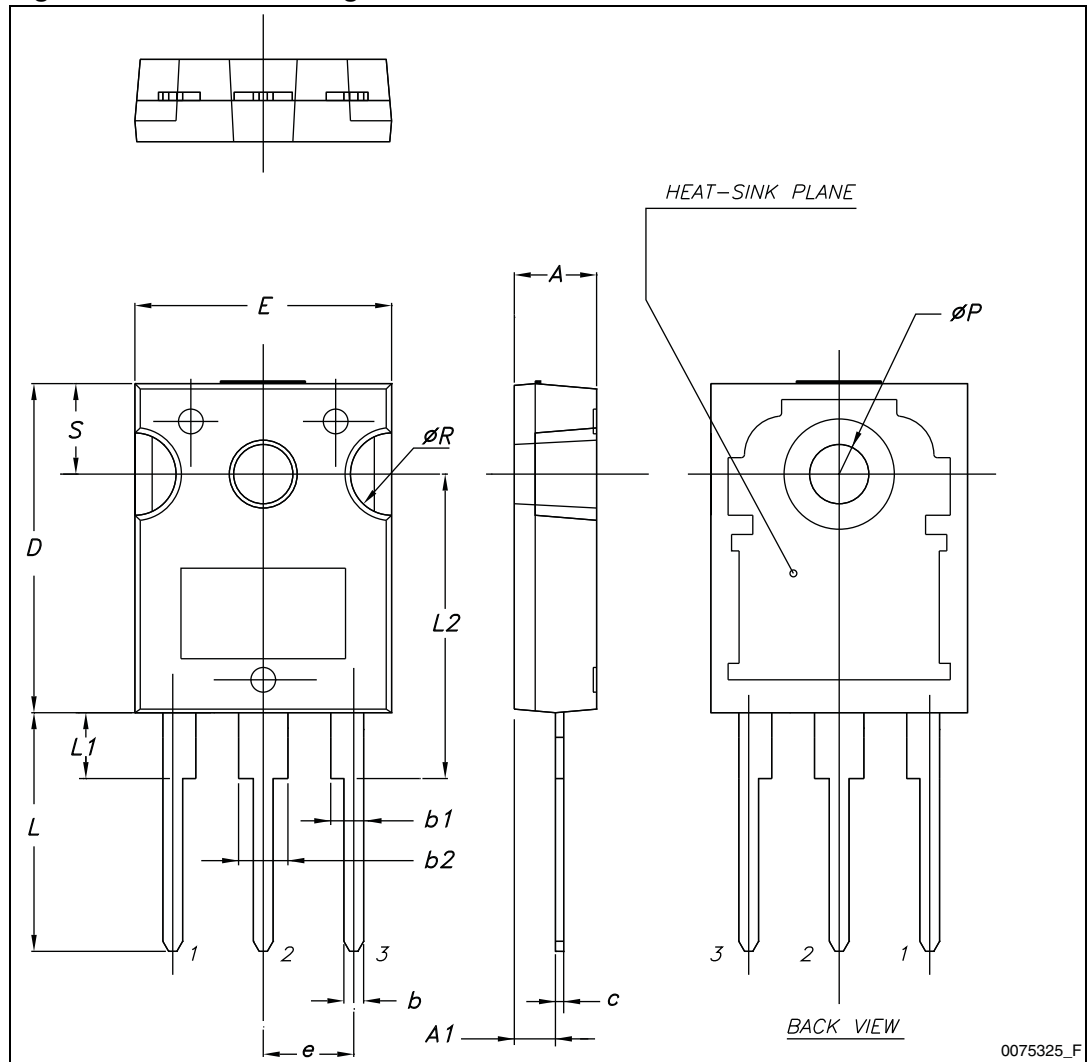

Table 12. TO-247 mechanical data

Dim.	mm		
	Min.	Typ.	Max.
A	4.85		5.15
A1	2.20		2.60
b	1.0		1.40
b1	2.0		2.40
b2	3.0		3.40
c	0.40		0.80
D	19.85		20.15
E	15.45		15.75
e		5.45	
L	14.20		14.80
L1	3.70		4.30
L2		18.50	
ØP	3.55		3.65
ØR	4.50		5.50
S		5.50	

Figure 28. TO-247 drawing



0075325_F

5 Packaging mechanical data

Table 13. D²PAK (TO-263) tape and reel mechanical data

Tape			Reel		
Dim.	mm		Dim.	mm	
	Min.	Max.		Min.	Max.
A0	10.5	10.7	A		330
B0	15.7	15.9	B	1.5	
D	1.5	1.6	C	12.8	13.2
D1	1.59	1.61	D	20.2	
E	1.65	1.85	G	24.4	26.4
F	11.4	11.6	N	100	
K0	4.8	5.0	T		30.4
P0	3.9	4.1			
P1	11.9	12.1		Base qty	1000
P2	1.9	2.1		Bulk qty	1000
R	50				
T	0.25	0.35			
W	23.7	24.3			

Figure 29. Tape

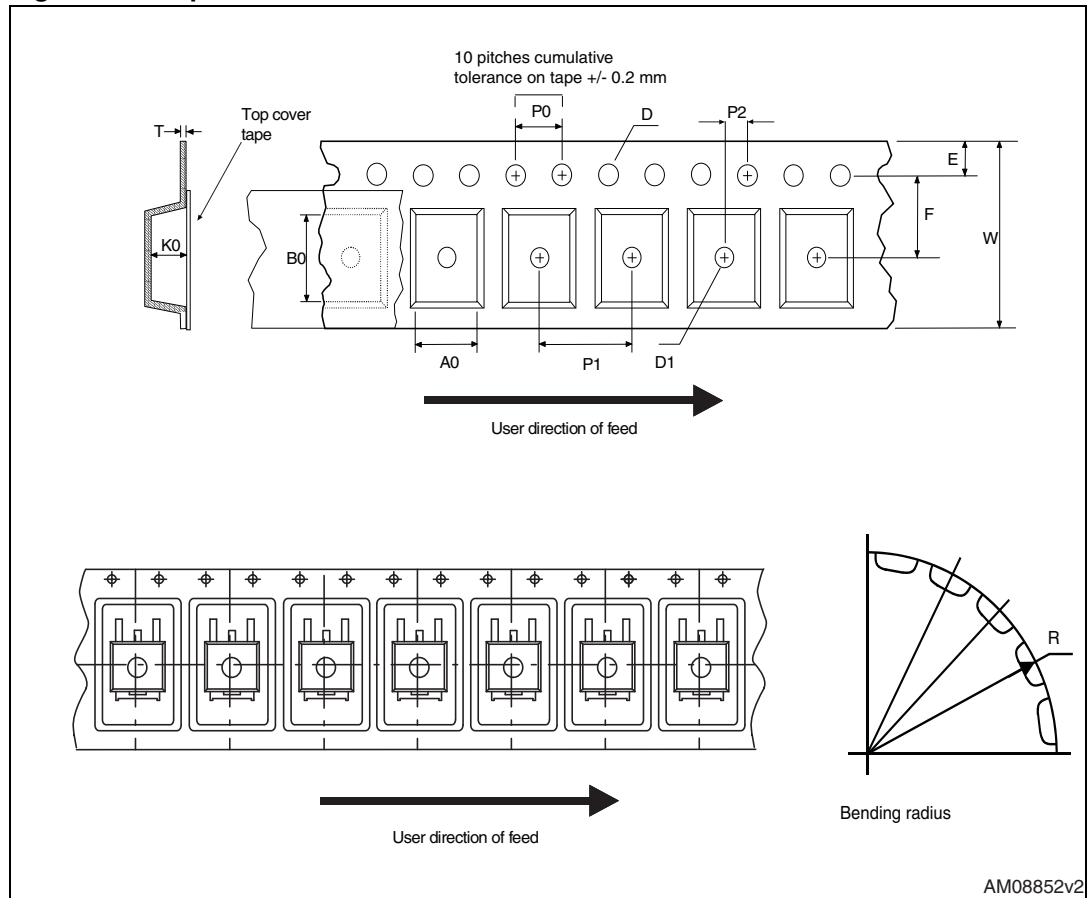
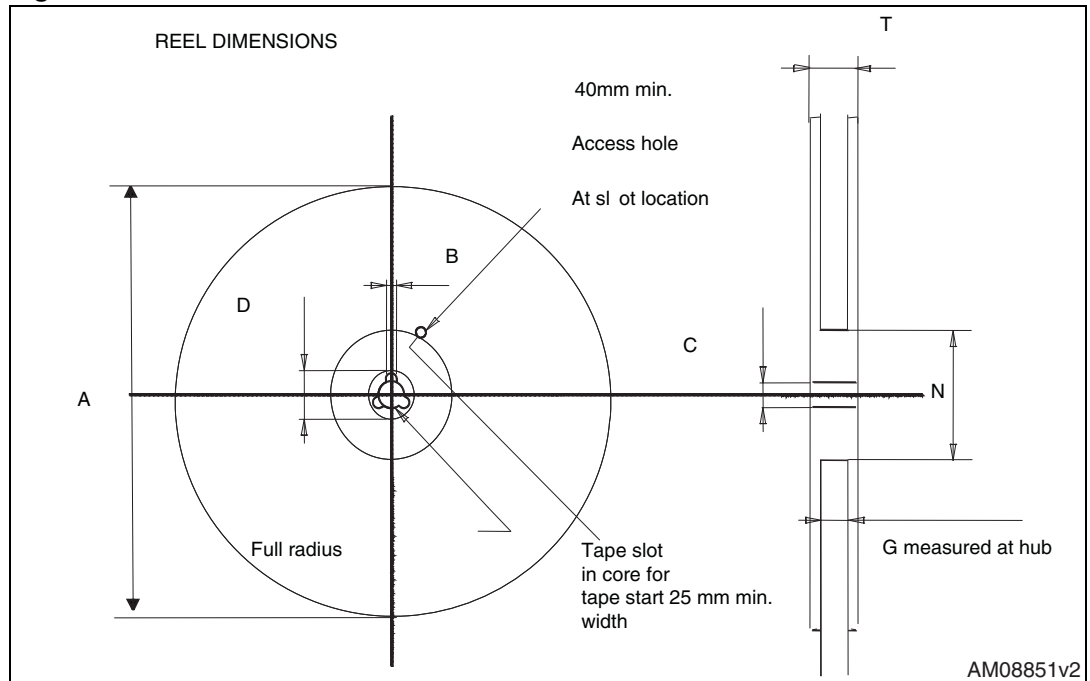

Figure 30. Reel



6 Revision history

Table 14. Document revision history

Date	Revision	Changes
30-Sep-2004	4	Preliminary version
26-Nov-2005	5	Complete version
07-Apr-2006	6	Modified value on Figure 8
15-May-2006	7	New dv/dt value on Table 5
20-Jul-2006	8	The document has been reformatted
20-Dec-2007	9	Updated I_D value on Table 2: Absolute maximum ratings
24-Mar-2010	10	Inserted dv/dt value in Table 2: Absolute maximum ratings
12-Sep-2011	11	Added new package and mechanical data : I ² PAK Minor text changes

Please Read Carefully:

Information in this document is provided solely in connection with ST products. STMicroelectronics NV and its subsidiaries ("ST") reserve the right to make changes, corrections, modifications or improvements, to this document, and the products and services described herein at any time, without notice.

All ST products are sold pursuant to ST's terms and conditions of sale.

Purchasers are solely responsible for the choice, selection and use of the ST products and services described herein, and ST assumes no liability whatsoever relating to the choice, selection or use of the ST products and services described herein.

No license, express or implied, by estoppel or otherwise, to any intellectual property rights is granted under this document. If any part of this document refers to any third party products or services it shall not be deemed a license grant by ST for the use of such third party products or services, or any intellectual property contained therein or considered as a warranty covering the use in any manner whatsoever of such third party products or services or any intellectual property contained therein.

UNLESS OTHERWISE SET FORTH IN ST'S TERMS AND CONDITIONS OF SALE ST DISCLAIMS ANY EXPRESS OR IMPLIED WARRANTY WITH RESPECT TO THE USE AND/OR SALE OF ST PRODUCTS INCLUDING WITHOUT LIMITATION IMPLIED WARRANTIES OF MERCHANTABILITY, FITNESS FOR A PARTICULAR PURPOSE (AND THEIR EQUIVALENTS UNDER THE LAWS OF ANY JURISDICTION), OR INFRINGEMENT OF ANY PATENT, COPYRIGHT OR OTHER INTELLECTUAL PROPERTY RIGHT.

UNLESS EXPRESSLY APPROVED IN WRITING BY TWO AUTHORIZED ST REPRESENTATIVES, ST PRODUCTS ARE NOT RECOMMENDED, AUTHORIZED OR WARRANTED FOR USE IN MILITARY, AIR CRAFT, SPACE, LIFE SAVING, OR LIFE SUSTAINING APPLICATIONS, NOR IN PRODUCTS OR SYSTEMS WHERE FAILURE OR MALFUNCTION MAY RESULT IN PERSONAL INJURY, DEATH, OR SEVERE PROPERTY OR ENVIRONMENTAL DAMAGE. ST PRODUCTS WHICH ARE NOT SPECIFIED AS "AUTOMOTIVE GRADE" MAY ONLY BE USED IN AUTOMOTIVE APPLICATIONS AT USER'S OWN RISK.

Resale of ST products with provisions different from the statements and/or technical features set forth in this document shall immediately void any warranty granted by ST for the ST product or service described herein and shall not create or extend in any manner whatsoever, any liability of ST.

ST and the ST logo are trademarks or registered trademarks of ST in various countries.

Information in this document supersedes and replaces all information previously supplied.

The ST logo is a registered trademark of STMicroelectronics. All other names are the property of their respective owners.

© 2011 STMicroelectronics - All rights reserved

STMicroelectronics group of companies

Australia - Belgium - Brazil - Canada - China - Czech Republic - Finland - France - Germany - Hong Kong - India - Israel - Italy - Japan - Malaysia - Malta - Morocco - Philippines - Singapore - Spain - Sweden - Switzerland - United Kingdom - United States of America

www.st.com

Компания «Life Electronics» занимается поставками электронных компонентов импортного и отечественного производства от производителей и со складов крупных дистрибьюторов Европы, Америки и Азии.

С конца 2013 года компания активно расширяет линейку поставок компонентов по направлению коаксиальный кабель, кварцевые генераторы и конденсаторы (керамические, пленочные, электролитические), за счёт заключения дистрибьюторских договоров

Мы предлагаем:

- Конкурентоспособные цены и скидки постоянным клиентам.
- Специальные условия для постоянных клиентов.
- Подбор аналогов.
- Поставку компонентов в любых объемах, удовлетворяющих вашим потребностям.
- Приемлемые сроки поставки, возможна ускоренная поставка.
- Доставку товара в любую точку России и стран СНГ.
- Комплексную поставку.
- Работу по проектам и поставку образцов.
- Формирование склада под заказчика.
- Сертификаты соответствия на поставляемую продукцию (по желанию клиента).
- Тестирование поставляемой продукции.
- Поставку компонентов, требующих военную и космическую приемку.
- Входной контроль качества.
- Наличие сертификата ISO.

В составе нашей компании организован Конструкторский отдел, призванный помогать разработчикам, и инженерам.

Конструкторский отдел помогает осуществить:

- Регистрацию проекта у производителя компонентов.
- Техническую поддержку проекта.
- Защиту от снятия компонента с производства.
- Оценку стоимости проекта по компонентам.
- Изготовление тестовой платы монтаж и пусконаладочные работы.



Тел: +7 (812) 336 43 04 (многоканальный)
Email: org@lifeelectronics.ru