

STK404-070NGEVB, STK404-120NGEVB, STK404-140NGEVB



ON Semiconductor®

<http://onsemi.com>

STK404-000N Series Evaluation Board User's Manual

EVAL BOARD USER'S MANUAL

Thick-Film Hybrid IC for use used in from 60 W to 180 W × 1ch class AB audio power amplifiers.

This Evaluation Board User's Manual describes the set-up and use of the STK404-000N Series Evaluation Board for SANYO Semiconductor (An ON Semiconductor Company).

Thick-Film Hybrid IC for use in from 60 W to 180 W × 1ch class AB audio power amplifiers devices STK404-070N-E, STK404-120N-E and STK404-140N-E.

For data sheets and additional on these devices, please visit the ON Semiconductor website at www.onsemi.com.

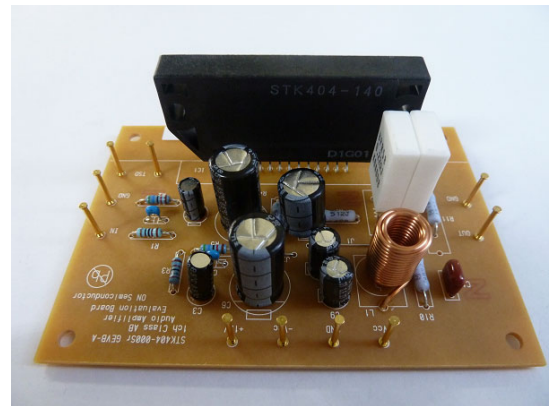
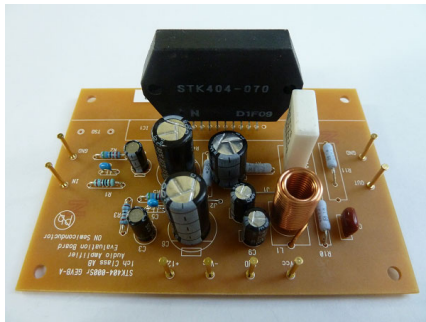

Figure 1. STK404-000N Series Evaluation Board

EVALUATION BOARD FOR STK404-070N, -120N, -140N



(100 mm × 70 mm × 1.6 mm,
Phenol 1-layer Board)

Figure 2. STK404-070NGEVB

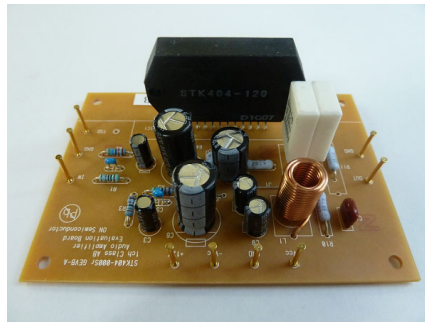

(100 mm × 70 mm × 1.6 mm,
Phenol 1-layer Board)

Figure 3. STK404-120NGEVB

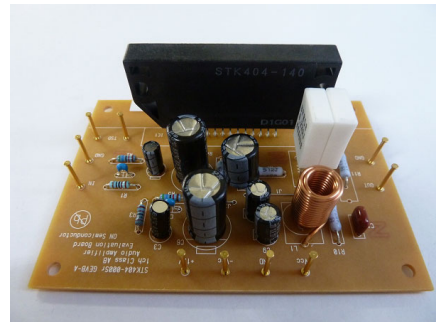

(100 mm × 70 mm × 1.6 mm,
Phenol 1-layer Board)

Figure 4. STK404-140NGEVB

Table 1. SELECTION GUIDE

	STK404-070N-E	STK404-120N-E	STK404-140N-E
Output1 (10%/1 kHz)	60 W × 1ch	120 W × 1ch	180 W × 1ch
Output2 (1%/20 Hz to 20 kHz)	40 W × 1ch	80 W × 1ch	120 W × 1ch
Maximum Rating V_{CC} max (no sig.)	±46 V	±65 V	±78 V
Maximum Rating V_{CC} (6 Ω)	±39 V	±59 V	±73 V
Recommended Operating V_{CC} (6 Ω)	±30 V	±41 V	±51 V
Package Size	44.0 × 25.6 × 8.5 (mm)	46.6 × 25.5 × 8.5 (mm)	59.2 × 25.5 × 8.5 (mm)

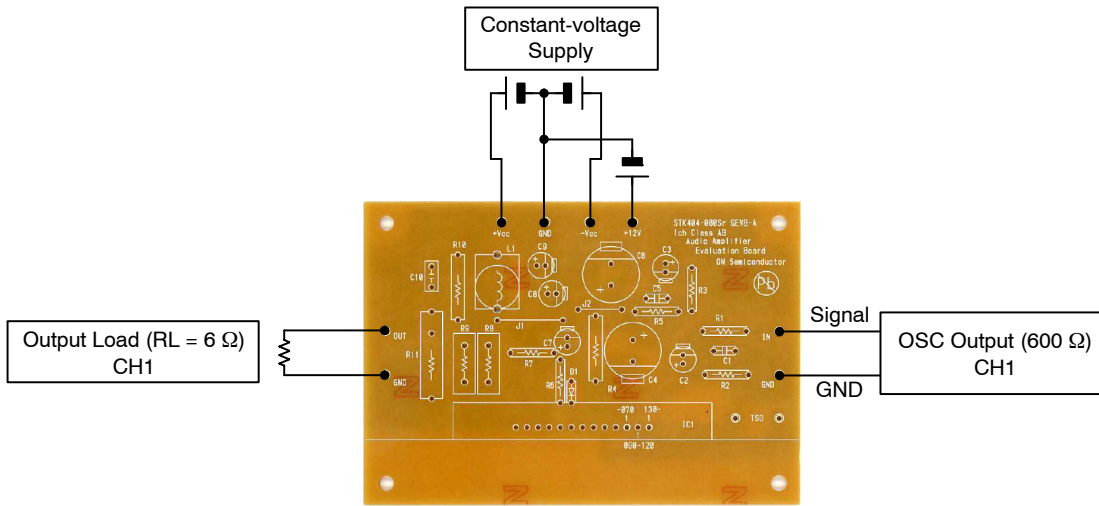

Figure 5. Characteristics Confirmation

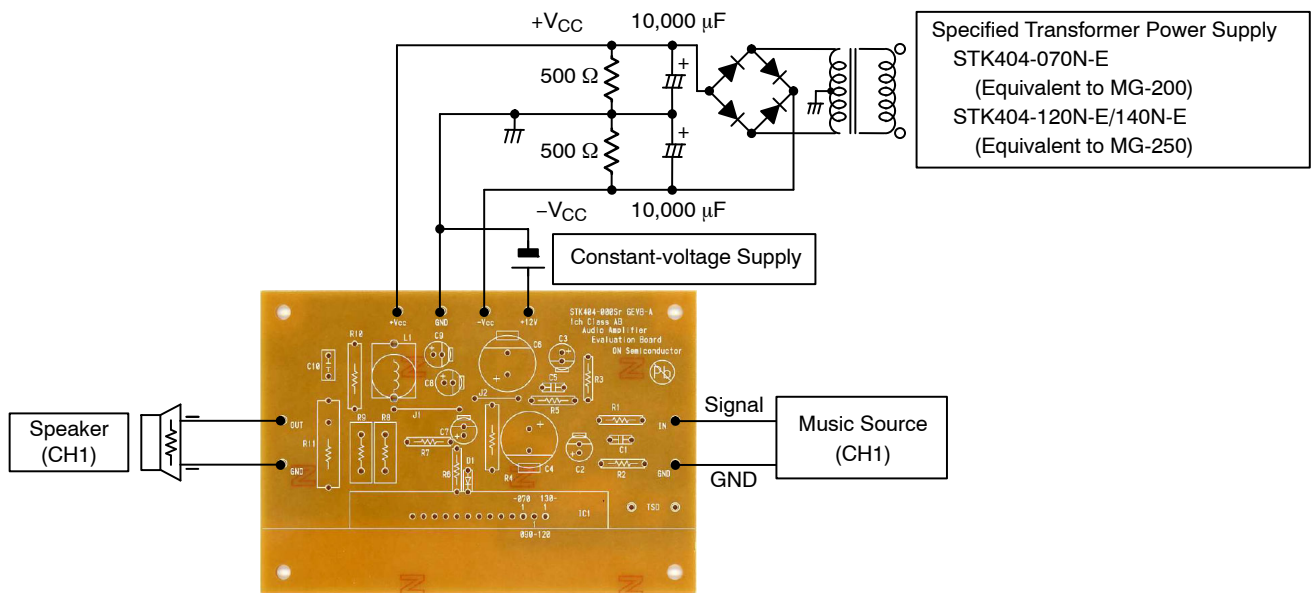

Figure 6. Sound Quality Configuration, Load Short-circuit Test, Noise Examination

STK404-070NGEVB, STK404-120NGEVB, STK404-140NGEVB

STK404-000NSR PCB PARTS LIST

Table 2. PCB NAME: STK404-000SR GEVB - A

Type (IC1)	STK404-070N-E	STK404-120N-E	STK404-140N-E
Position of (1)pin	Third from the Right End	Second from the Right End	The Right End
Location			
R1	1 k Ω	←	←
R2	56 k Ω	←	←
R3	1.8 k Ω	←	←
R4	100 Ω /1 W	←	←
R5	56 k Ω	←	←
R6	10 k Ω /1 W	4.7 k Ω /1 W	5.1 k Ω /1 W
R7	10 k Ω /1 W	4.7 k Ω /1 W	5.1 k Ω /1 W
R8	0.22 Ω /5 W	←	←
R9	-	0.22 Ω /5 W	←
R10	4.7 Ω /1 W	←	←
R11	4.7 Ω /1 W	←	←
C1	470 pF	←	←
C2	2.2 μ F/50 V	←	←
C3	10 μ F/50 V	←	←
C4	100 μ F/100 V	←	←
C5	5 pF	←	←
C6	100 μ F/50 V	←	←
C7	47 μ F/100 V	←	←
C8	10 μ F/100 V	←	←
C9	10 μ F/100 V	←	←
C10	0.1 μ F	←	←
D1	200 V/0.5 A	Short	Short
L1	2.2 μ H	←	←
J1	15 mm	←	←
J2	10 mm	←	←

TEST CIRCUITS

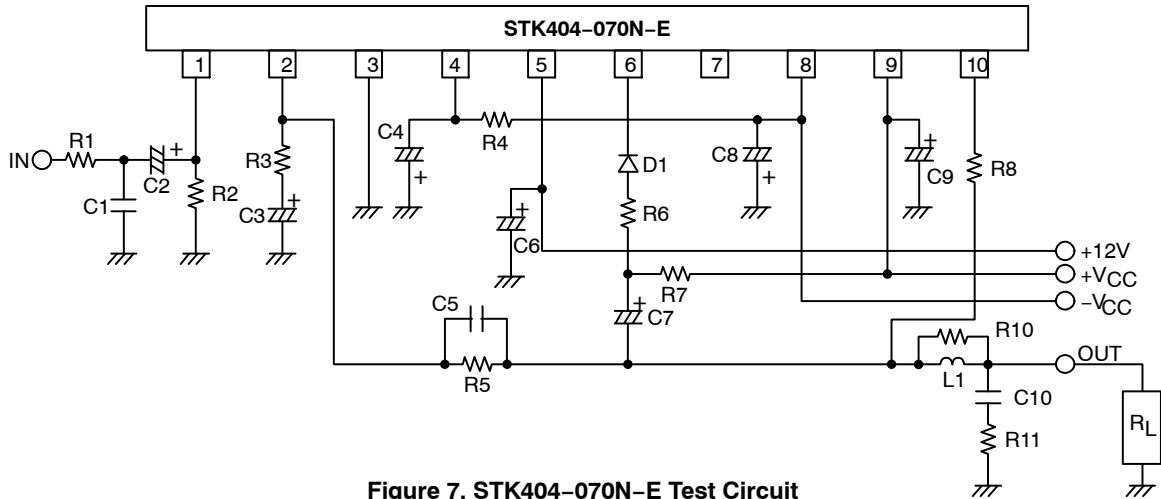

Figure 7. STK404-070N-E Test Circuit

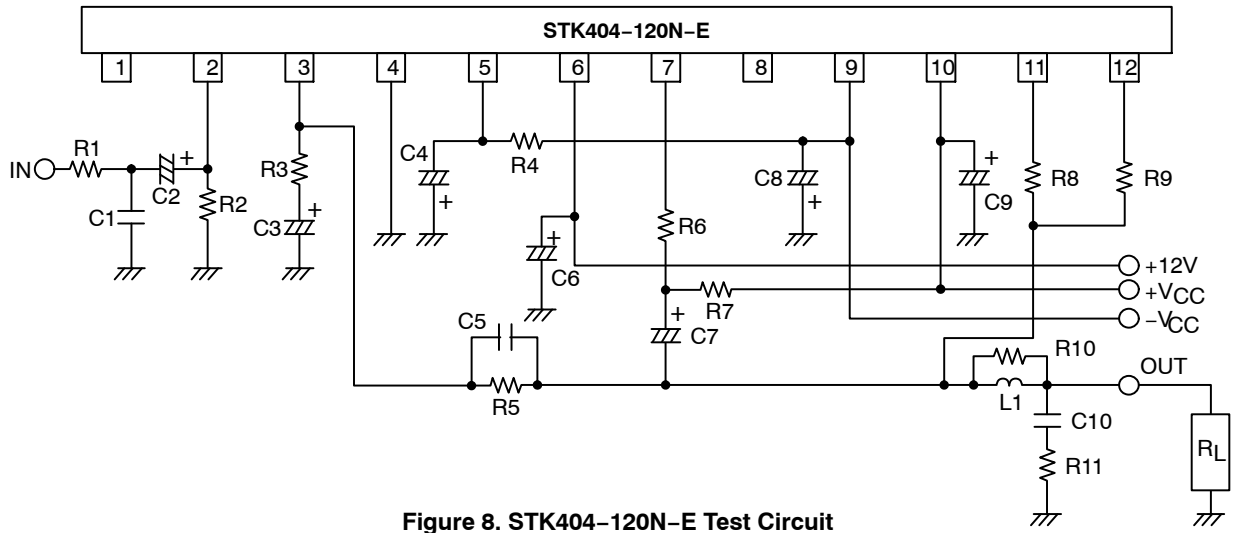

Figure 8. STK404-120N-E Test Circuit

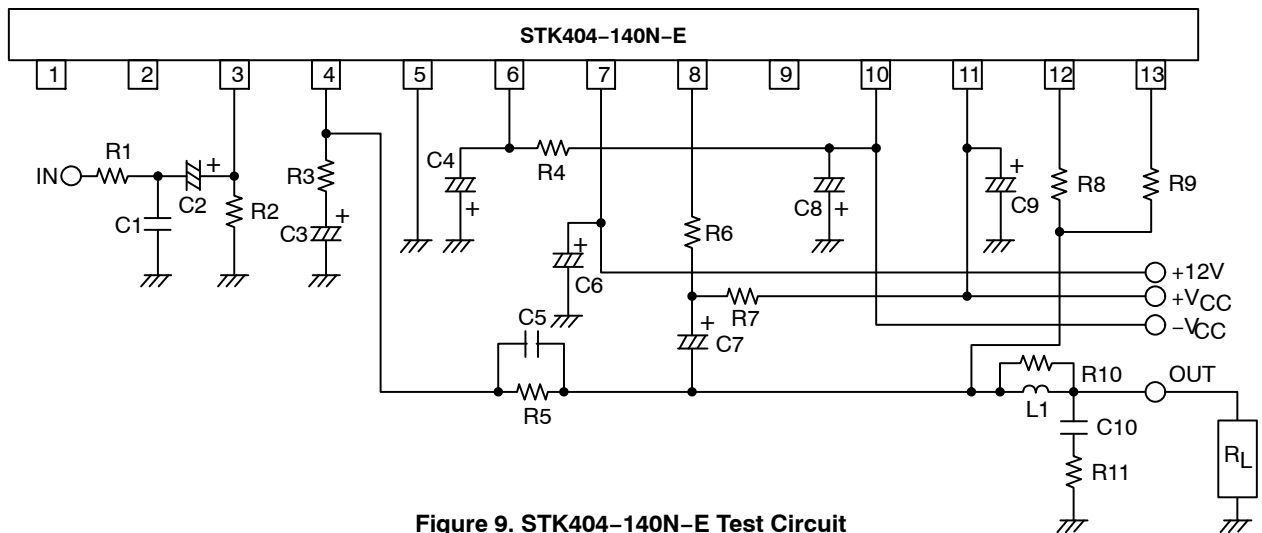

Figure 9. STK404-140N-E Test Circuit

STK404-070NGEVB, STK404-120NGEVB, STK404-140NGEVB

SUBSTRATE SPECIFICATIONS

(Substrate Recommended for Operation of STK404-070N/120N/140N)

Size: 100 mm × 70 mm × 1.6 mm, Phenol 1-layer Board
Material: Phenol
Copper Side (35 μ)

PCB LAYOUT EXAMPLE

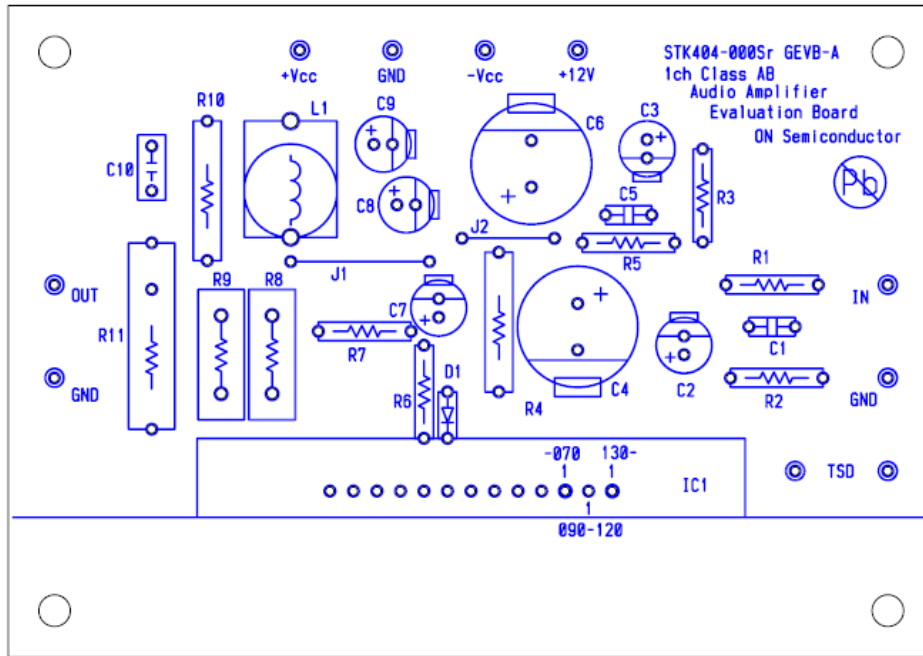

Figure 10. Top View

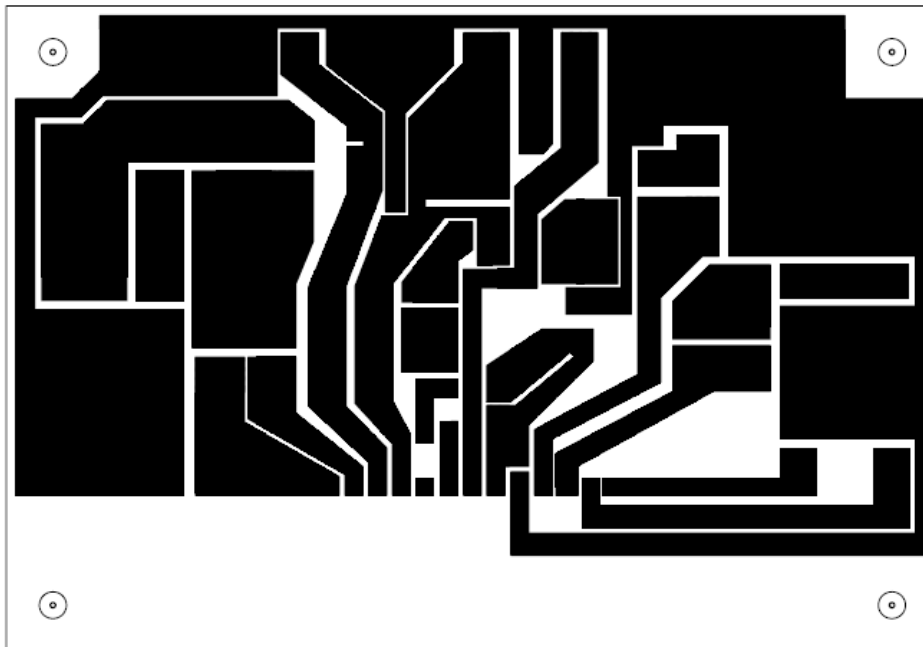

Figure 11. Top View

CHARACTERISTIC OF EVALUATION BOARD - STK404-070N-E

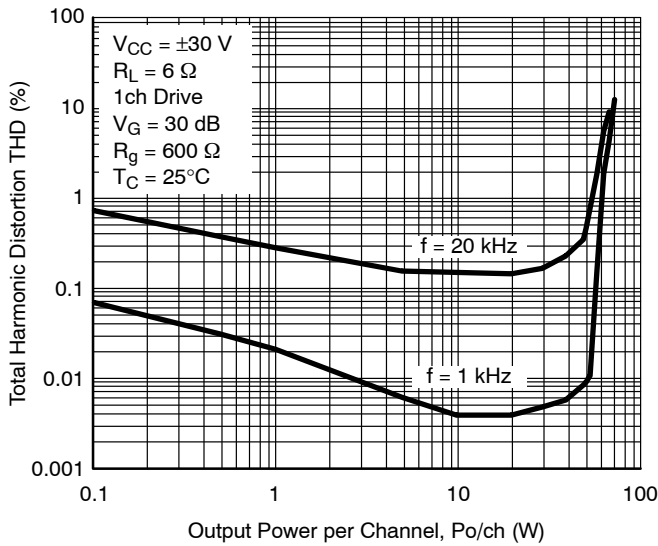

Figure 12. THD vs. Po

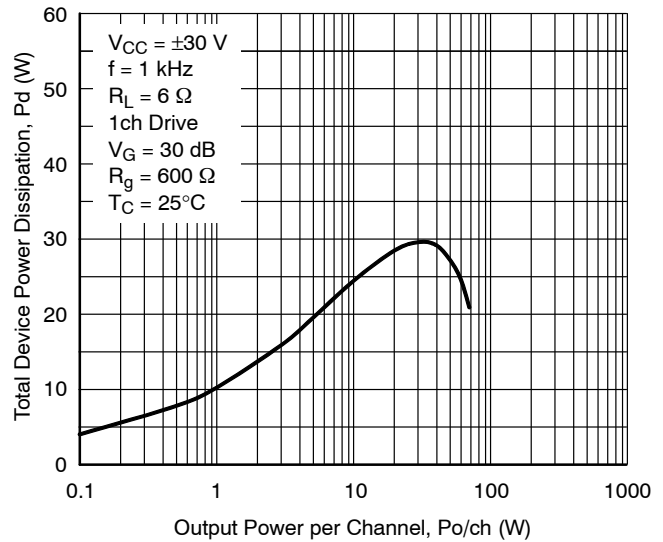

Figure 13. Pd vs. Po

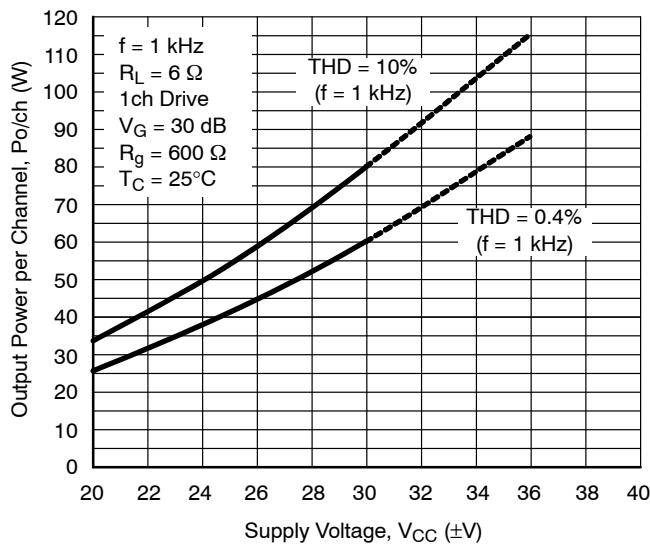

Figure 14. Po vs. VCC

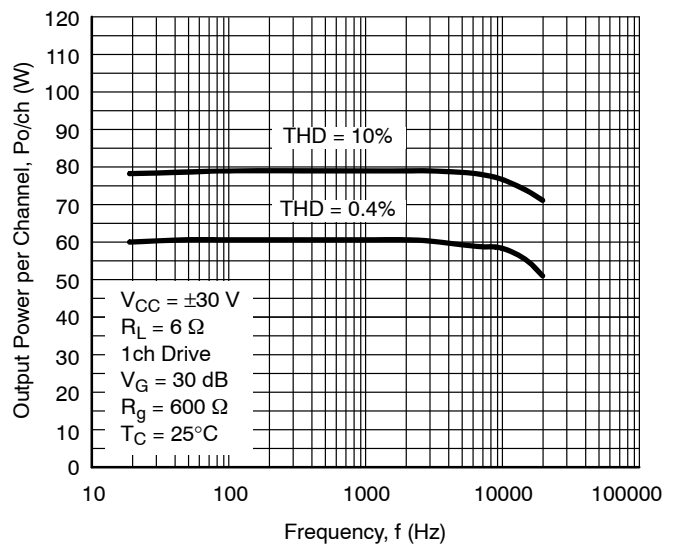

Figure 15. Po vs. f

CHARACTERISTIC OF EVALUATION BOARD – STK404-120N-E

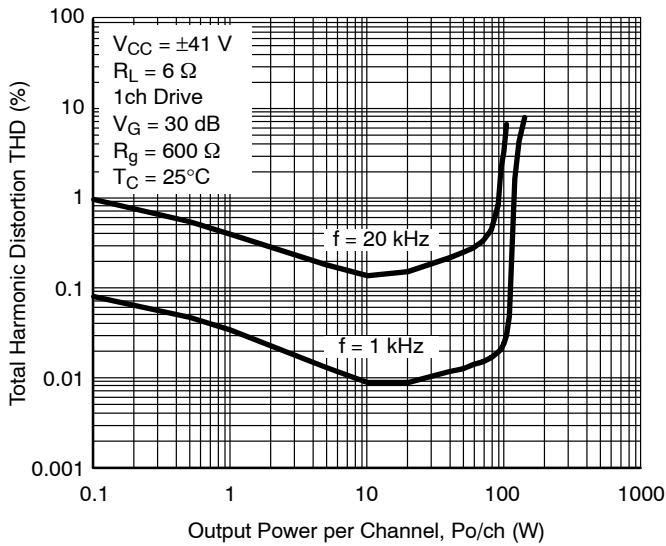

Figure 16. THD vs. Po

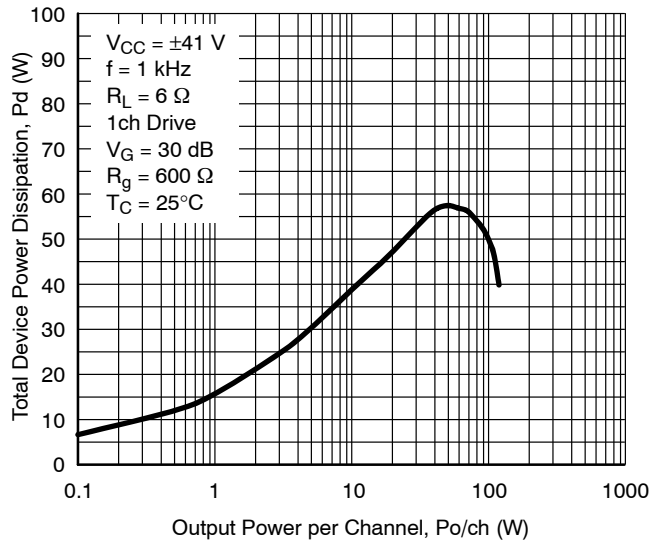

Figure 17. Pd vs. Po

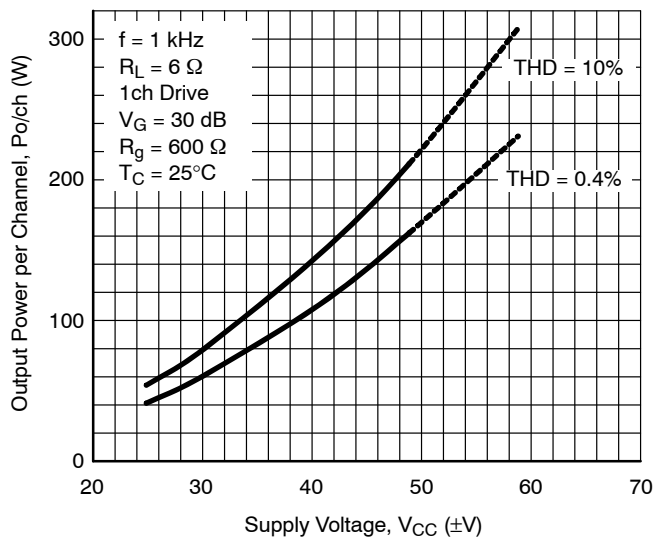

Figure 18. Po vs. VCC

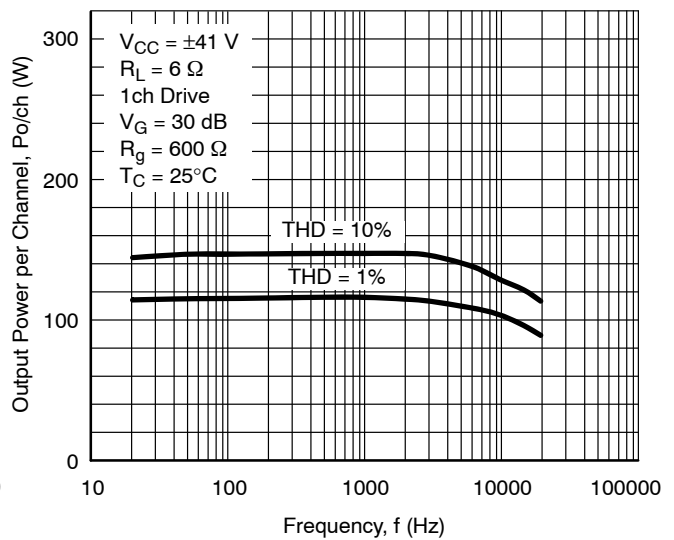

Figure 19. Po vs. f

CHARACTERISTIC OF EVALUATION BOARD - STK404-140N-E

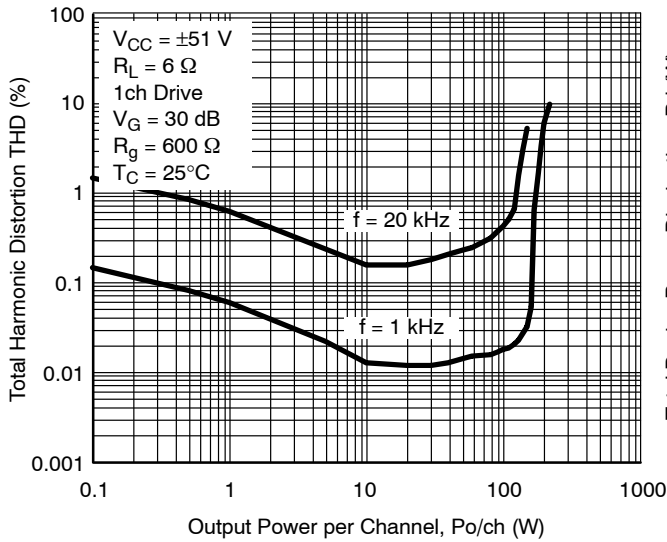

Figure 20. THD vs. Po

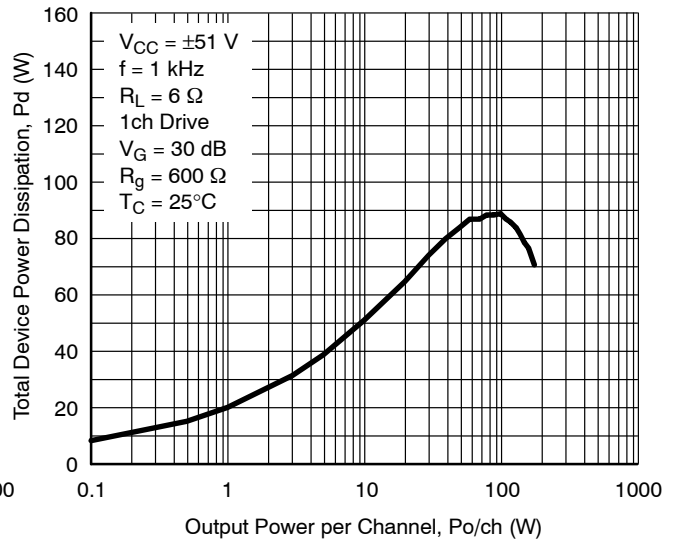

Figure 21. Pd vs. Po

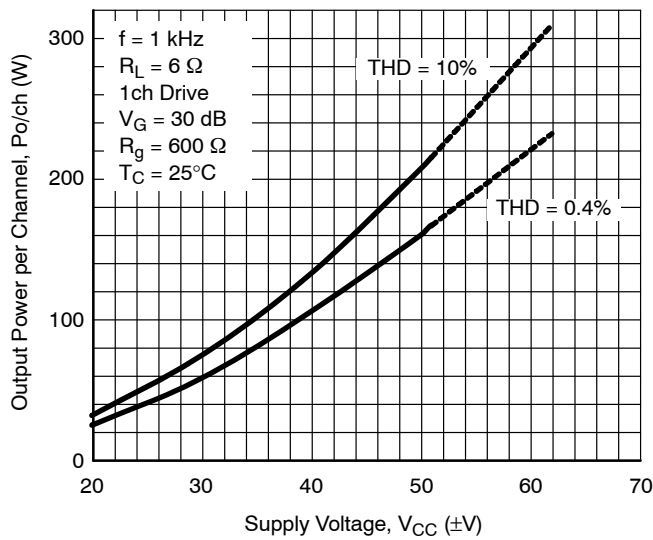

Figure 22. Po vs. VCC

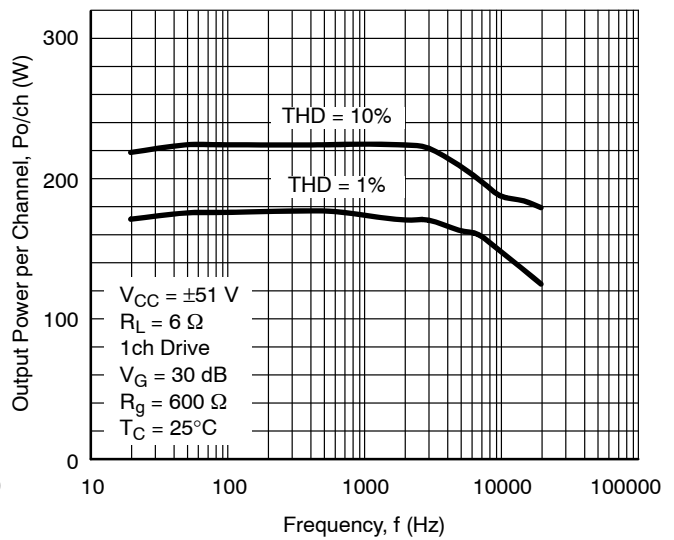

Figure 23. Po vs. f

STK404-070NGEVB, STK404-120NGEVB, STK404-140NGEVB

STAND-BY CONTROL & MUTE CONTROL APPLICATION

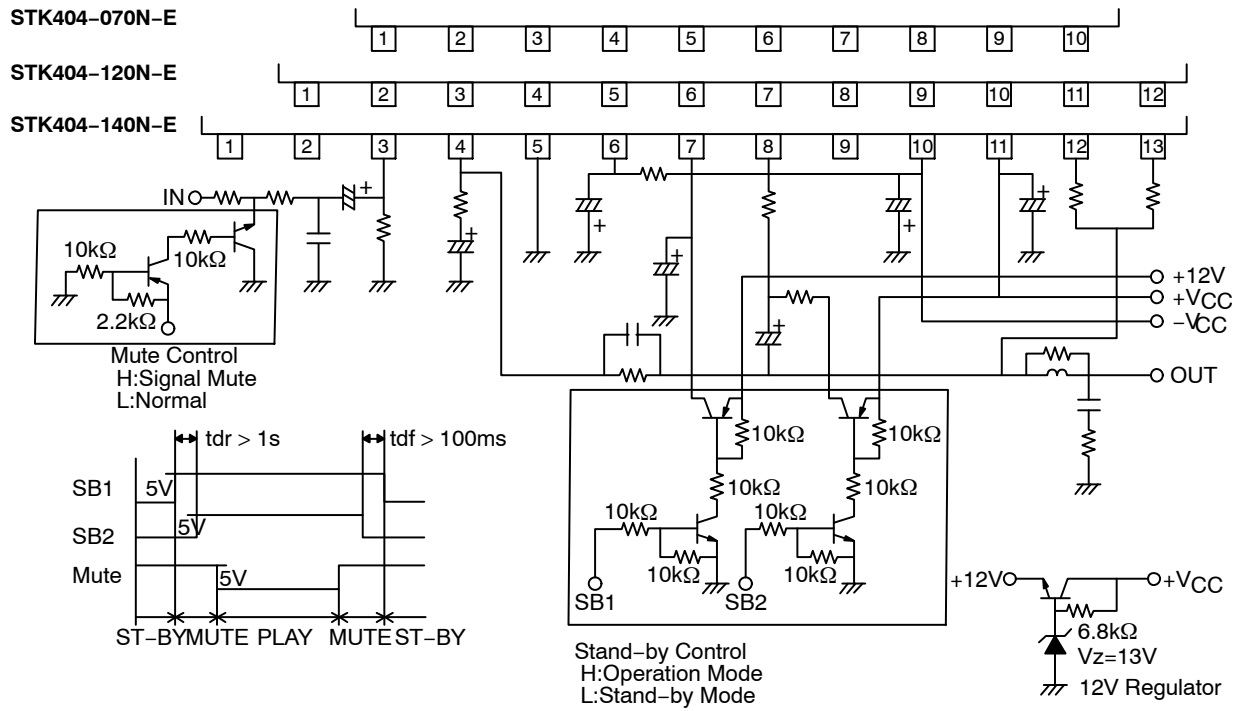

Figure 24. STK404-000-Ese Stand-by Control & Mute Control Application

THERMAL SHUT DOWN APPLICATION

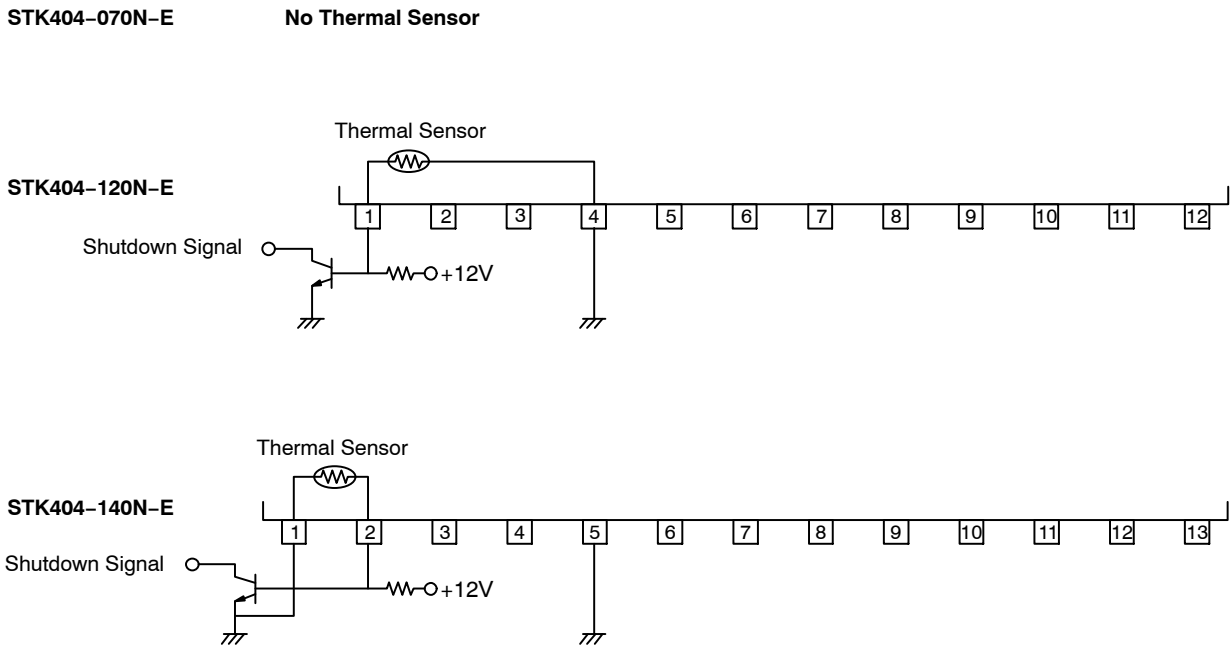

Figure 25. STK404-000-Esr Thermal Shut Down Application

THERMAL SENSOR CHARACTERISTIC

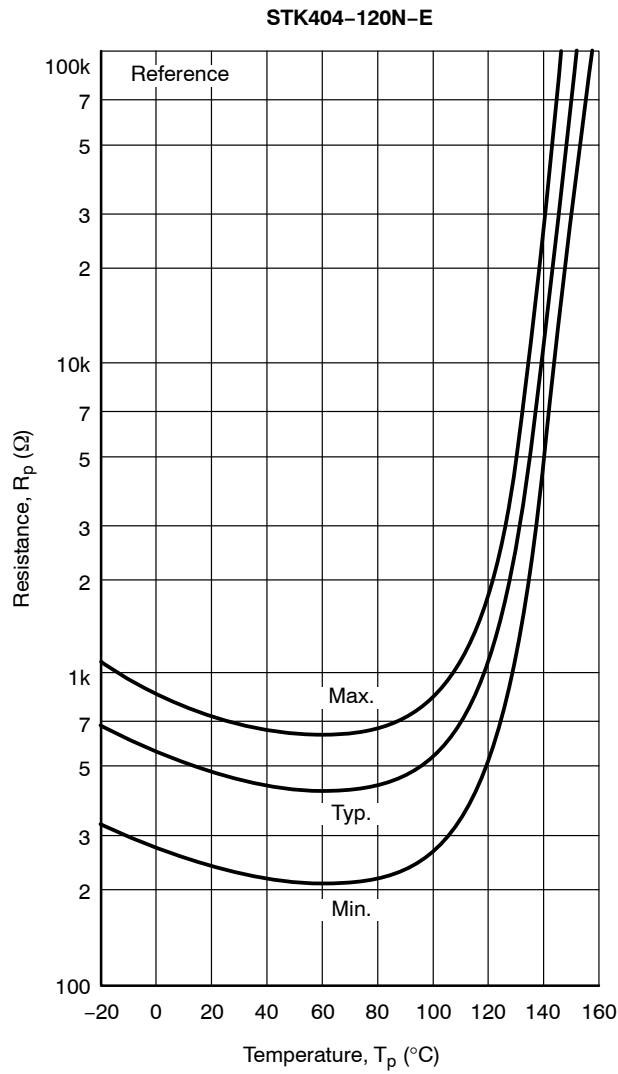

Figure 26. R_p vs. T_p

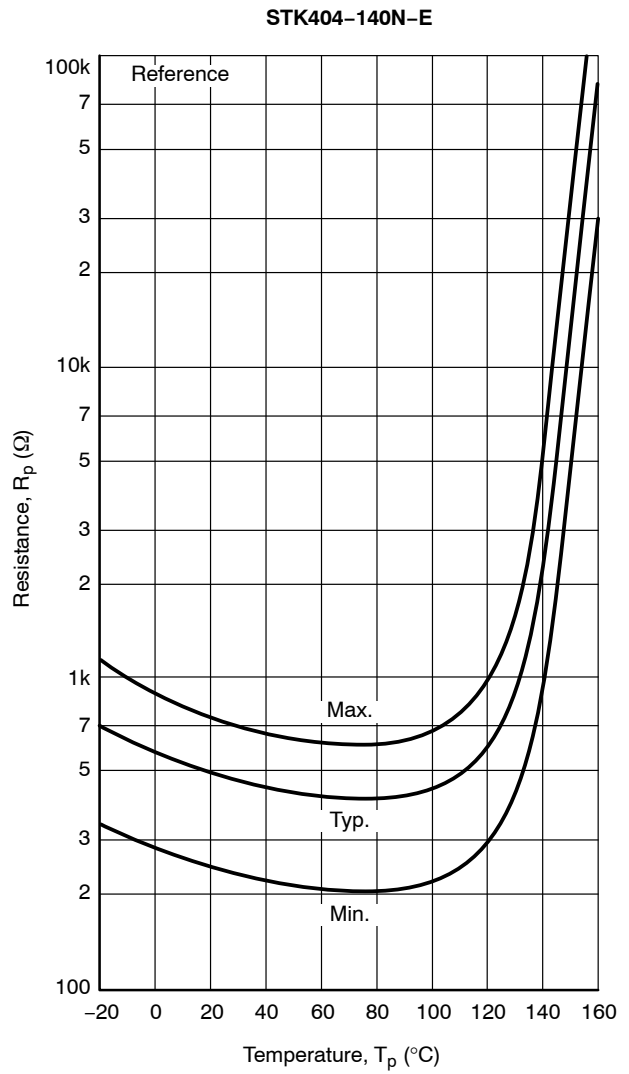

Figure 27. R_p vs. T_p

STK404-070NGEVB, STK404-120NGEVB, STK404-140NGEVB

ROAD-SHORT & DC VOLTAGE PROTECTION APPLICATION

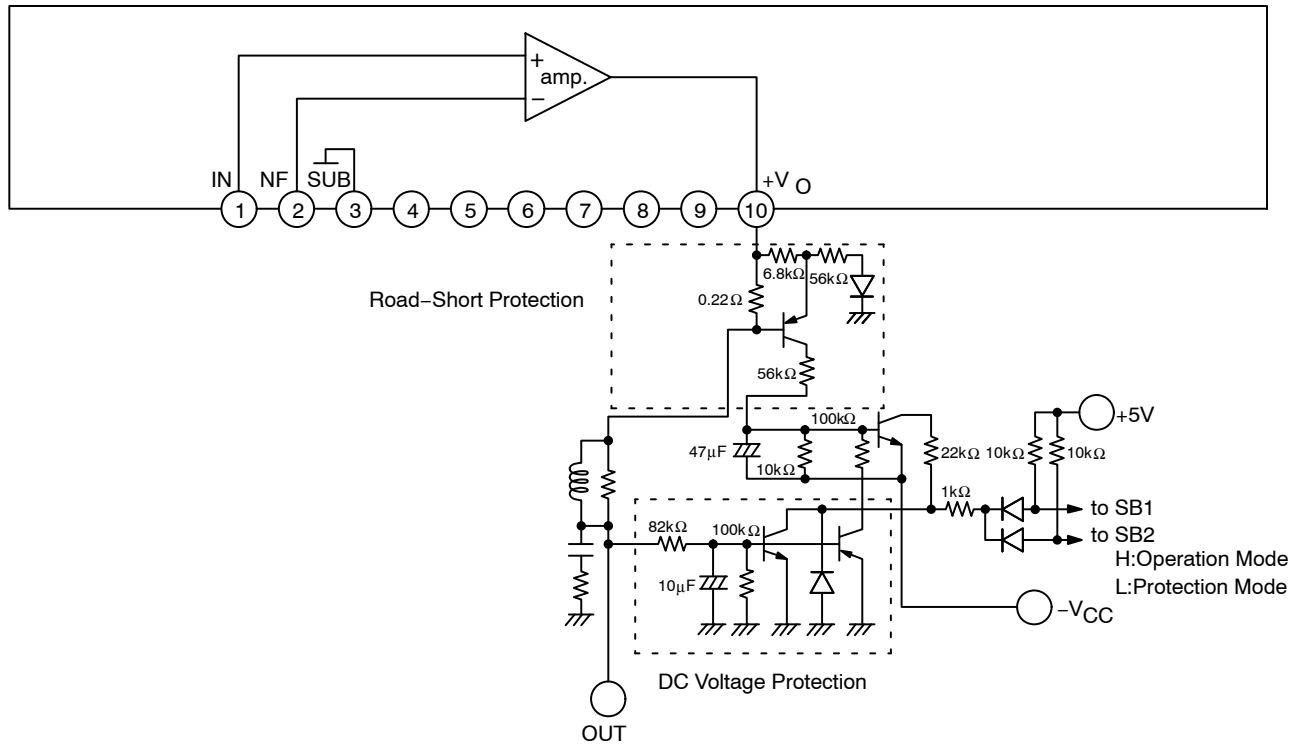

Figure 28. STK404-070N-E Road-short & DC Voltage Protection Application

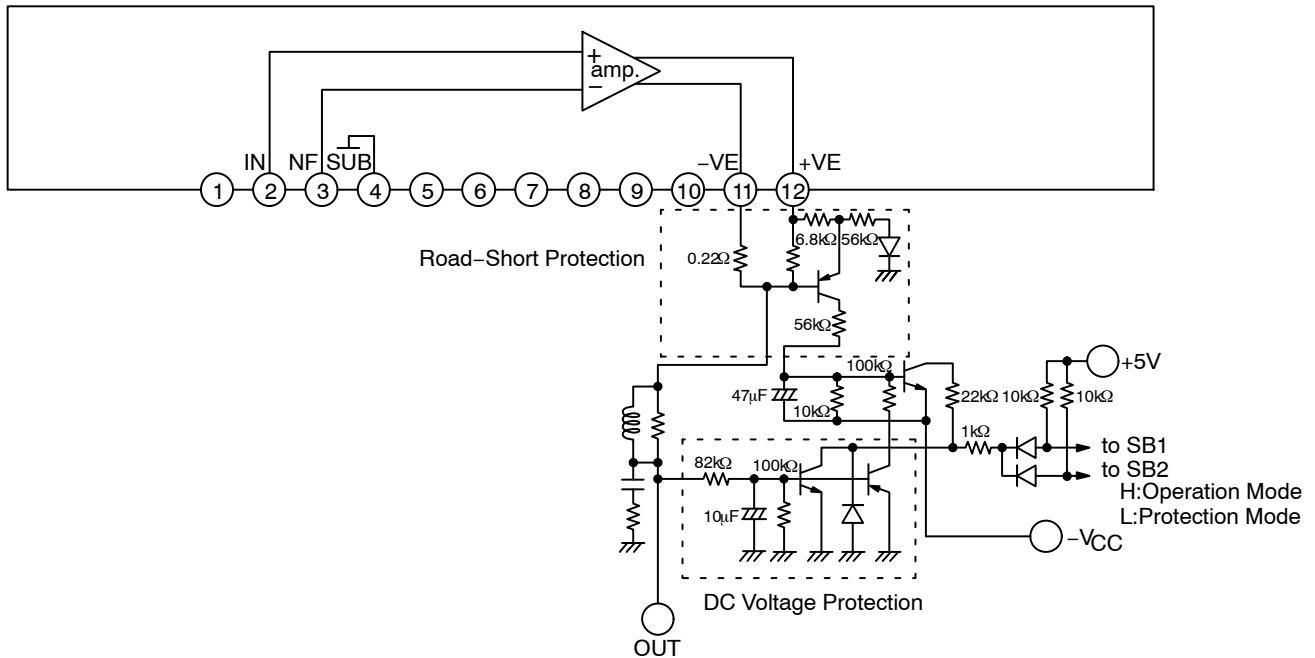

Figure 29. STK404-120N-E Road-short & DC Voltage Protection Application

STK404-070NGEVB, STK404-120NGEVB, STK404-140NGEVB

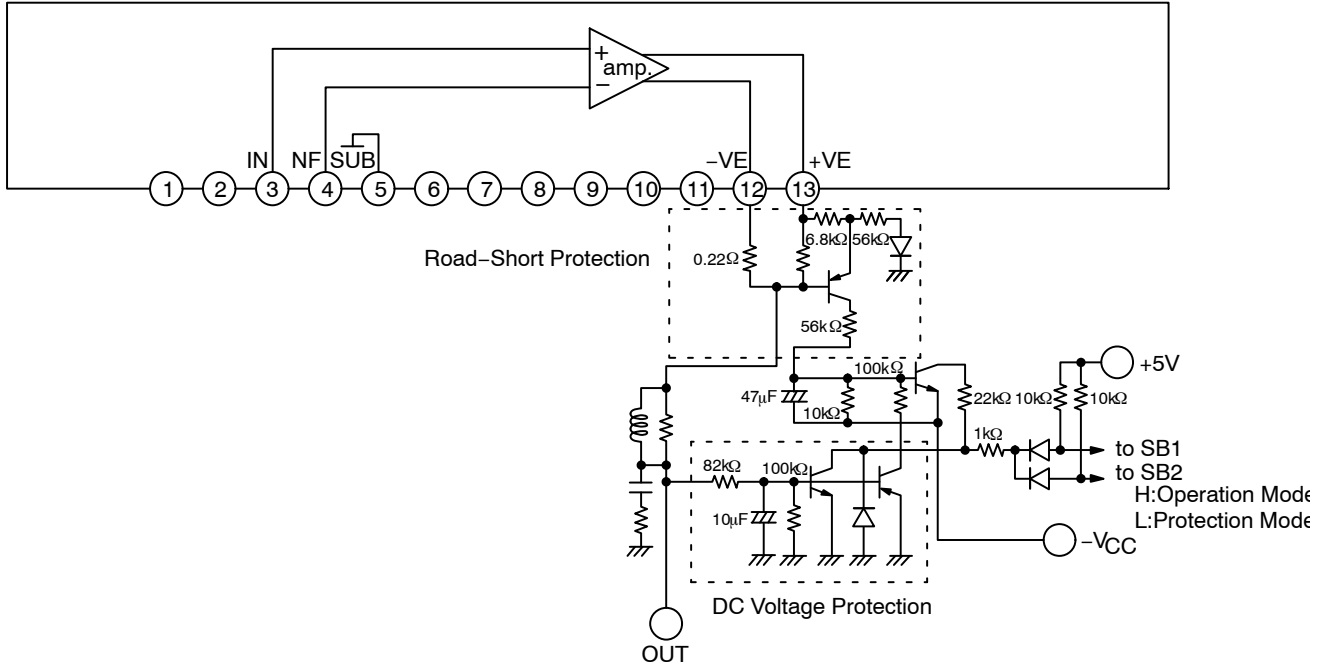

Figure 30. STK404-140N-E Road-short & DC Voltage Protection Application

ON Semiconductor and the ON Semiconductor logo are trademarks of Semiconductor Components Industries, LLC dba ON Semiconductor or its subsidiaries in the United States and/or other countries. ON Semiconductor owns the rights to a number of patents, trademarks, copyrights, trade secrets, and other intellectual property. A listing of ON Semiconductor's product/patent coverage may be accessed at www.onsemi.com/site/pdf/Patent-Marking.pdf. ON Semiconductor is an Equal Opportunity/Affirmative Action Employer. This literature is subject to all applicable copyright laws and is not for resale in any manner.

The evaluation board/kit (research and development board/kit) (hereinafter the "board") is not a finished product and is as such not available for sale to consumers. The board is only intended for research, development, demonstration and evaluation purposes and should as such only be used in laboratory/development areas by persons with an engineering/technical training and familiar with the risks associated with handling electrical/mechanical components, systems and subsystems. This person assumes full responsibility/liability for proper and safe handling. Any other use, resale or redistribution for any other purpose is strictly prohibited.

The board is delivered "AS IS" and without warranty of any kind including, but not limited to, that the board is production-worthy, that the functions contained in the board will meet your requirements, or that the operation of the board will be uninterrupted or error free. ON Semiconductor expressly disclaims all warranties, express, implied or otherwise, including without limitation, warranties of fitness for a particular purpose and non-infringement of intellectual property rights.

ON Semiconductor reserves the right to make changes without further notice to any board.

You are responsible for determining whether the board will be suitable for your intended use or application or will achieve your intended results. Prior to using or distributing any systems that have been evaluated, designed or tested using the board, you agree to test and validate your design to confirm the functionality for your application. Any technical, applications or design information or advice, quality characterization, reliability data or other services provided by ON Semiconductor shall not constitute any representation or warranty by ON Semiconductor, and no additional obligations or liabilities shall arise from ON Semiconductor having provided such information or services.

The boards are not designed, intended, or authorized for use in life support systems, or any FDA Class 3 medical devices or medical devices with a similar or equivalent classification in a foreign jurisdiction, or any devices intended for implantation in the human body. Should you purchase or use the board for any such unintended or unauthorized application, you shall indemnify and hold ON Semiconductor and its officers, employees, subsidiaries, affiliates, and distributors harmless against all claims, costs, damages, and expenses, and reasonable attorney fees arising out of, directly or indirectly, any claim of personal injury or death associated with such unintended or unauthorized use, even if such claim alleges that ON Semiconductor was negligent regarding the design or manufacture of the board.

This evaluation board/kit does not fall within the scope of the European Union directives regarding electromagnetic compatibility, restricted substances (RoHS), recycling (WEEE), FCC, CE or UL, and may not meet the technical requirements of these or other related directives.

FCC WARNING – This evaluation board/kit is intended for use for engineering development, demonstration, or evaluation purposes only and is not considered by ON Semiconductor to be a finished end product fit for general consumer use. It may generate, use, or radiate radio frequency energy and has not been tested for compliance with the limits of computing devices pursuant to part 15 of FCC rules, which are designed to provide reasonable protection against radio frequency interference. Operation of this equipment may cause interference with radio communications, in which case the user shall be responsible, at its expense, to take whatever measures may be required to correct this interference.

ON Semiconductor does not convey any license under its patent rights nor the rights of others.

LIMITATIONS OF LIABILITY: ON Semiconductor shall not be liable for any special, consequential, incidental, indirect or punitive damages, including, but not limited to the costs of requalification, delay, loss of profits or goodwill, arising out of or in connection with the board, even if ON Semiconductor is advised of the possibility of such damages. In no event shall ON Semiconductor's aggregate liability from any obligation arising out of or in connection with the board, under any theory of liability, exceed the purchase price paid for the board, if any.

For more information and documentation, please visit www.onsemi.com.

PUBLICATION ORDERING INFORMATION

LITERATURE FULFILLMENT:

Email Requests to: orderlit@onsemi.com

ON Semiconductor Website: www.onsemi.com

TECHNICAL SUPPORT

North American Technical Support:

Voice Mail: 1 800-282-9855 Toll Free USA/Canada

Phone: 011 421 33 790 2910

Europe, Middle East and Africa Technical Support:

Phone: 00421 33 790 2910

For additional information, please contact your local Sales Representative

Компания «Life Electronics» занимается поставками электронных компонентов импортного и отечественного производства от производителей и со складов крупных дистрибьюторов Европы, Америки и Азии.

С конца 2013 года компания активно расширяет линейку поставок компонентов по направлению коаксиальный кабель, кварцевые генераторы и конденсаторы (керамические, пленочные, электролитические), за счёт заключения дистрибьюторских договоров

Мы предлагаем:

- Конкурентоспособные цены и скидки постоянным клиентам.
- Специальные условия для постоянных клиентов.
- Подбор аналогов.
- Поставку компонентов в любых объемах, удовлетворяющих вашим потребностям.
- Приемлемые сроки поставки, возможна ускоренная поставка.
- Доставку товара в любую точку России и стран СНГ.
- Комплексную поставку.
- Работу по проектам и поставку образцов.
- Формирование склада под заказчика.
- Сертификаты соответствия на поставляемую продукцию (по желанию клиента).
- Тестирование поставляемой продукции.
- Поставку компонентов, требующих военную и космическую приемку.
- Входной контроль качества.
- Наличие сертификата ISO.

В составе нашей компании организован Конструкторский отдел, призванный помогать разработчикам, и инженерам.

Конструкторский отдел помогает осуществить:

- Регистрацию проекта у производителя компонентов.
- Техническую поддержку проекта.
- Защиту от снятия компонента с производства.
- Оценку стоимости проекта по компонентам.
- Изготовление тестовой платы монтаж и пусконаладочные работы.



Тел: +7 (812) 336 43 04 (многоканальный)

Email: org@lifeelectronics.ru