



GLASS WIRE WOUND SENSOR TYPE GO

RTD Temperature Sensor

SPECIFICATIONS

- **Temperature sensor**
- **Large temperature range**
From -200°C to +400°C
- **High vibrations resistant**
- **Resistant to external forces and pressures**
- **Small dimensions**
- **Good temperature stability**
- **Abrasion resistance**
- **Good pull up force resistance of leads**
- **Resistance to aggressive environment (acid, oil, solvent)**

One or two platinum bands wound on solid glass core and homogeneously sealed with external tube.

FEATURES

- Nominal Value: 100 Ω at 0°C
Tolerance according to IEC 60751: class W 0.3, W 0.15 and W 0.1
Temperature coefficient $\alpha = 3850$ ppm/K
Closer tolerances in restricted temperature ranges
- Connection Wires: Platinum coated nickel wires
- The lead wires connection is pull up force resistant
- Housing Advise: Can be used in most of liquids without protection (water, oil, solvent, acid...).
- Options: - Lead wires length
 - Extension cable
 - Glass shape (diameter, length, bent)
 - Ohmic values

APPLICATIONS

- Chemical and pharmaceutical industry
- Food industry
- H.V.A.C.
- Power generation plants
- Analytical equipment
- Aerospace industry
- Marine...

GLASS WIRE WOUND SENSOR TYPE GO

RTD Temperature Sensor

PERFORMANCE SPECIFICATIONS

Type	Designation	Reference	Nominal reference (Ohm at 0°C)	L WL D AL1 AL2 A (Dimensions in mm)					Self-heating in air (K/mW)	Response time (s)				
				Water v = 0,4 m/s		Air v = 1 m/s								
				t0,5	t0,9	t0,5	t0,9							
Tolerance Class W 0.3 = ± (0.3+0.005 Itl) From -196°C to + 400°C														
1Pt100	GO 1020	SB0789	100	10	6	2,0	15	-	0,25	0,26	0,14	0,35	7	21
1Pt100	GO 1327	SB0865	100	13	9	2,7	15	-	0,25	0,11	0,40	1,30	13	25
1Pt100	GO 1545	SB0862	100	15	9,5	4,5	15	-	0,25	0,09	0,80	2,40	16	40
1Pt100	GO 2327	SB0870	100	23	16	2,7	15	-	0,25	0,11	0,40	1,30	13	25
1Pt100	GO 3045	SB0873	100	30	21	4,5	15	-	0,25	0,09	0,80	2,40	16	40
2Pt100	GO 4845	SB0765	100	48	35	4,5	10	12	0,25	0,09	0,80	2,40	16	40
Tolerance Class W 0.15 = ± (0.15+0.002 Itl) From -100°C to + 250°C														
1Pt100	GO 1020	SB0794	100	10	6	2,0	15	-	0,25	0,26	0,14	0,35	7	21
1Pt100	GO 1327	SB0866	100	13	9	2,7	15	-	0,25	0,11	0,40	1,30	13	25
1Pt100	GO 1545	SB0863	100	15	9,5	4,5	15	-	0,25	0,09	0,80	2,40	16	40
1Pt100	GO 2327	SB0871	100	23	16	2,7	15	-	0,25	0,11	0,40	1,30	13	25
1Pt100	GO 3045	SB0874	100	30	21	4,5	15	-	0,25	0,09	0,80	2,40	16	40
Tolerance Class W 0.1 = ± (0.1+0.0017 Itl) From 0°C to + 150°C														
1Pt100	GO 1020	SB0795	100	10	6	2,0	15	-	0,25	0,26	0,14	0,35	7	21
1Pt100	GO 1327	SB0867	100	13	9	2,7	15	-	0,25	0,11	0,40	1,30	13	25
1Pt100	GO 1545	SB0864	100	15	9,5	4,5	15	-	0,25	0,09	0,80	2,40	16	40
1Pt100	GO 2327	SB0872	100	23	16	2,7	15	-	0,25	0,11	0,40	1,30	13	25
1Pt100	GO 3045	SB0875	100	30	21	4,5	15	-	0,25	0,09	0,80	2,40	16	40

VALUES FOR Pt100

°C	Ohms	Ohms/°C	°C	Ohms	Ohms/°C
-200	18.52	0.432	150	157.33	0.374
-150	39.72	0.417	200	175.86	0.368
-100	60.26	0.405	250	194.10	0.362
-50	80.31	0.397	300	212.05	0.356
0	100	0.391	350	229.72	0.350
50	119.40	0.385	400	247.09	0.345
100	138.51	0.379			

GLASS WIRE WOUND SENSOR TYPE GO

RTD Temperature Sensor

BLOCK DIAGRAM

DIMENSIONAL TOLERANCES:

L	(length of body)	= ± 2mm
D	(diameter of body)	= ± 0.2mm
AL	(connection wire length)	= ± 2mm
A	(connection wire diameter)	= ± 0.02 mm

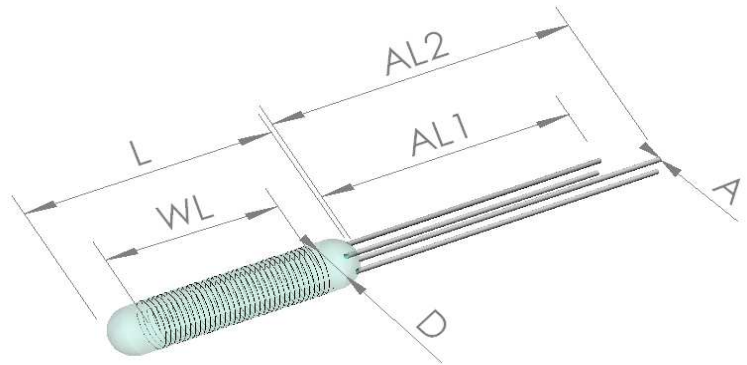

ORDERING INFORMATION

NORTH AMERICA

Measurement Specialties, Inc.,
a TE Connectivity Company
910 Turnpike Road
Shrewsbury, MA 01545
United States
+1 508-842-0516
+1 508-842-0342
temperature.cs.amer@meas-spec.com

EUROPE

Measurement Specialties (Europe), Ltd.,
a TE Connectivity Company
48, rue de Frégy
77610 Fontenay Trésigny
France
Tel: +33(0) 1 64 42 52 52
Fax: +33(0) 1 64 42 63 17
sales.ftny.fr@meas-spec.com

ASIA

Measurement Specialties (China), Ltd.,
a TE Connectivity Company
No. 26 Langshan Road
Shenzhen High-Tech Park (North)
Nanshan District, Shenzhen 518057
China
Tel: +86 755 3330 5088
Fax: +86 755 3330 5099
temperature.cs.asia@meas-spec.com

TE.com/sensorsolutions

Measurement Specialties, Inc., a TE Connectivity company.

Measurement Specialties, TE Connectivity, TE Connectivity (logo) and EVERY CONNECTION COUNTS are trademarks. All other logos, products and/or company names referred to herein might be trademarks of their respective owners.

The information given herein, including drawings, illustrations and schematics which are intended for illustration purposes only, is believed to be reliable. However, TE Connectivity makes no warranties as to its accuracy or completeness and disclaims any liability in connection with its use. TE Connectivity's obligations shall only be as set forth in TE Connectivity's Standard Terms and Conditions of Sale for this product and in no case will TE Connectivity be liable for any incidental, indirect or consequential damages arising out of the sale, resale, use or misuse of the product. Users of TE Connectivity products should make their own evaluation to determine the suitability of each such product for the specific application.

© 2015 TE Connectivity Ltd. family of companies All Rights Reserved.

Компания «Life Electronics» занимается поставками электронных компонентов импортного и отечественного производства от производителей и со складов крупных дистрибьюторов Европы, Америки и Азии.

С конца 2013 года компания активно расширяет линейку поставок компонентов по направлению коаксиальный кабель, кварцевые генераторы и конденсаторы (керамические, пленочные, электролитические), за счёт заключения дистрибьюторских договоров

Мы предлагаем:

- Конкурентоспособные цены и скидки постоянным клиентам.
- Специальные условия для постоянных клиентов.
- Подбор аналогов.
- Поставку компонентов в любых объемах, удовлетворяющих вашим потребностям.
- Приемлемые сроки поставки, возможна ускоренная поставка.
- Доставку товара в любую точку России и стран СНГ.
- Комплексную поставку.
- Работу по проектам и поставку образцов.
- Формирование склада под заказчика.
- Сертификаты соответствия на поставляемую продукцию (по желанию клиента).
- Тестирование поставляемой продукции.
- Поставку компонентов, требующих военную и космическую приемку.
- Входной контроль качества.
- Наличие сертификата ISO.

В составе нашей компании организован Конструкторский отдел, призванный помогать разработчикам, и инженерам.

Конструкторский отдел помогает осуществить:

- Регистрацию проекта у производителя компонентов.
- Техническую поддержку проекта.
- Защиту от снятия компонента с производства.
- Оценку стоимости проекта по компонентам.
- Изготовление тестовой платы монтаж и пусконаладочные работы.



Тел: +7 (812) 336 43 04 (многоканальный)
Email: org@lifeelectronics.ru