

REV.	DESCRIPTION	DATE	APPROVED
C	Engineering Update w/o Changes	03/10/04	M. C.
D	Corrected Typos.	08/19/04	M. C.
E	Included Charts as Page 3, 4 & 5.	10/21/04	M. C.
F	Changed Storage & Operating Lower Temperature to -40.	11/02/04	M. C.
G	Image Orientation Update w/o Changes	02/28/05	M. C.
H	Added SM2-PGC-20 LED	09/29/06	M. C.

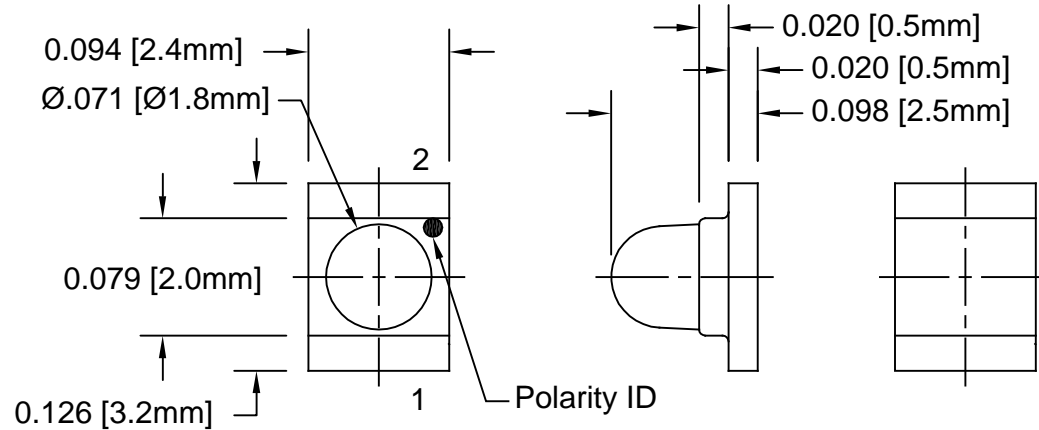

SM2-XXXX-20

\*REVERSE POLARITY



SM2-XXXXX-20

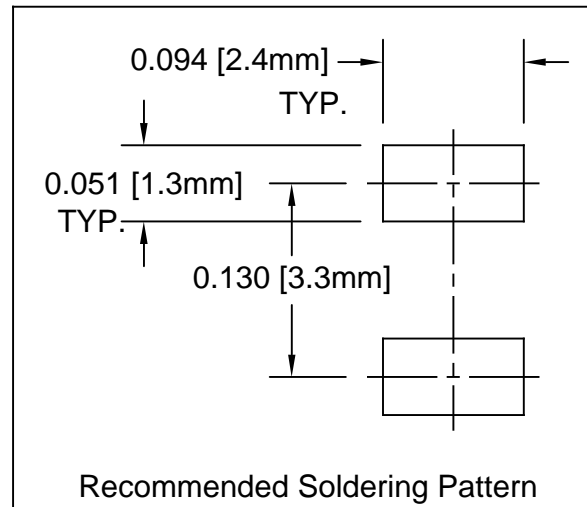

## ABSOLUTE MAXIMUM RATINGS (Ta=25° C)



REVERSE VOLTAGE	_____	5V
REVERSE CURRENT	_____	100uA
OPERATING TEMPERATURE RANGE	_____	-40° C - 85° C
STORAGE TEMPERATURE	_____	-40° C - 100° C
LEAD SOLDERING TEMPERATURE(1/16" FROM BODY)	_____	260° C FOR 5 SECONDS

STANDARD TOLERANCE ( UNLESS OTHERWISE SPECIFIED )		 4 THOMAS, IRVINE, CA. 92618 TEL: (949) 951-8808 FAX: (949) 951-3974	
DECIMALS	ANGULAR		
.X ±.1	X° ±1°		
.XX ±.02		 <b>TITLE:</b> SURFACE MOUNT LED, 1.8mm DOMED LENS	
.XXX ±.010			
DESIGNED: <b>David Green</b>	DATE: <b>10/21/02</b>	<b>PART NO:</b> SM2-XXXX-20 <b>REVISION:</b> H	
CHECKED: <b>M. Chen</b>	DATE: <b>10/21/02</b>		
		<b>CAGE CODE :</b> 32559 <b>SHEET #</b> 1 <b>OF</b> 6	
CAD GENERATED DOCUMENT, DO NOT MEASURE DRAWING.			

REV.	DESCRIPTION	DATE	APPROVED
	SEE SHEET#1.		

LED Part No.	Chip			Lens Appearance	Absolute Max. Ratings				Electro-Optical Data @ 20mA			Viewing Angle 2θ ½ (Deg)
	Material	Peak Wave Length λp(nm)	Emitted Color		Δλ (nm)	Pd (mW)	If (mA)	Peak If(mA)	Vf (V)		Iv (mcd)	
									TYP	MAX	TYP	
SM2-SBWC-20	GaN/Sic	430	SUPER BLUE	WATER CLEAR	60	150	30	150	4.0	4.5	64	20
SM2-UBWC-20	GaN	460	ULTRA BLUE	WATER CLEAR	68	150	30	150	3.4	4.0	288	20
SM2-UTC-20	InGaN	505	ULTRA TURQUOISE	WATER CLEAR	37	150	30	150	3.3	4.0	960	20
SM2-PGC-20	InGaN/SiC	510	GREEN	WATER CLEAR	20	120	30	125	3.5	4.0	900	20
SM2-UGC-20	InGaN	525	ULTRA GREEN	WATER CLEAR	40	150	30	150	3.2	3.8	960	20
SM2-GC-20	GaP	565	GREEN	WATER CLEAR	32	100	30	150	2.3	2.7	136	20
SM2-SGC-20	AlGaN	575	GREEN	WATER CLEAR	18	100	30	150	2.1	2.6	296	20
SM2-YC-20	GaAsP	586	YELLOW	WATER CLEAR	37	100	30	150	2.1	2.5	49	20
SM2-UYC-20	AlGaN	595	YELLOW	WATER CLEAR	32	100	30	150	2.0	2.5	456	20
SM2-UAC-20	AlGaN	600	AMBER	WATER CLEAR	20	100	30	150	1.9	2.4	600	20
SM2-SAC-20	AlGaN	610	AMBER	WATER CLEAR	25	100	30	150	1.9	2.4	416	20
SM2-UOC-20	AlGaN	620	ORANGE	WATER CLEAR	18	100	30	150	1.9	2.4	600	20
SM2-UHC-20	AlGaN	635	HE RED	WATER CLEAR	25	100	30	150	1.9	2.4	536	20
SM2-SHC-20	AlGaN	640	RED	WATER CLEAR	23	80	30	150	1.9	2.4	416	20
SM2-ERC-20*	GaAlAs	660	RED	WATER CLEAR	25	80	30	150	1.8	2.3	152	20
SM2-UWC-20	GaN	X=.29 Y=.30	WHITE	WATER CLEAR	-	150	30	150	3.4	4.0	250	60



\*ERC CHIP REVERSED POLARITY

STANDARD TOLERANCE ( UNLESS OTHERWISE SPECIFIED ) ±10% ALL VALUES      ANGULAR X° ± 5°		 <b>BIVAR</b> <sup>®</sup> 4 THOMAS, IRVINE, CA. 92618 TEL: (949) 951-8808    FAX: (949) 951-3974	
			
DESIGNED: <b>David Green</b>	DATE: <b>10/21/02</b>	TITLE: SURFACE MOUNT LED, 1.8mm DOMED LENS	
CHECKED: <b>M. Chen</b>	DATE: <b>10/21/02</b>	PART NO: <b>SM2-XXXX-20</b>	REVISION: <b>H</b>
		CAGE CODE : 32559	SHEET # 2 OF 6
CAD GENERATED DOCUMENT, DO NOT MEASURE DRAWING.			

REV.	DESCRIPTION	DATE	APPROVED
	SEE SHEET#1.		

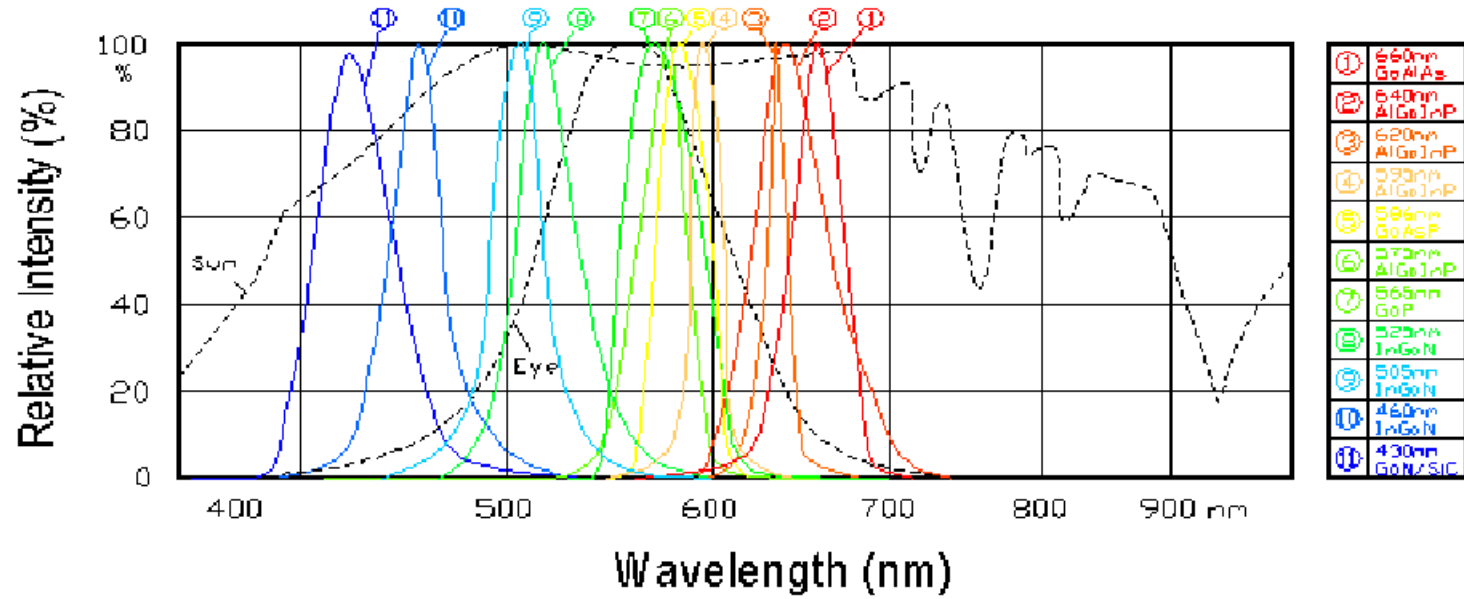
### Relative Intensity vs. Wavelength



STANDARD TOLERANCE (UNLESS OTHERWISE SPECIFIED) ±10% ALL VALUES		 <b>BIVAR</b> <sup>®</sup> 4 THOMAS, IRVINE, CA. 92618 TEL: (949) 951-8808 FAX: (949) 951-3974		
ANGULAR X° ± 5°				
		TITLE: SURFACE MOUNT LED, 1.8mm DOMED LENS		
		DESIGNED: <b>David Green</b>	DATE: <b>10/21/02</b>	PART NO: <b>SM2-XXXX-20</b>
CHECKED: <b>M. Chen</b>		DATE: <b>10/21/02</b>	CAGE CODE : 32559 SHEET # 3 OF 6	
CAD GENERATED DOCUMENT, DO NOT MEASURE DRAWING.				

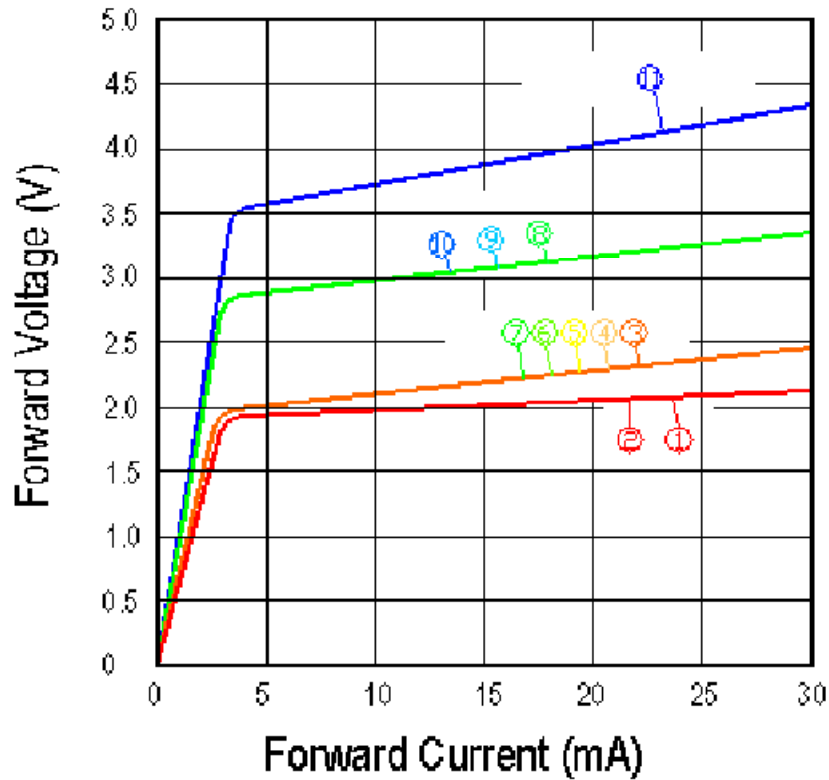

REV.	DESCRIPTION	DATE	APPROVED
	SEE SHEET#1.		

Forward Voltage vs. Forward Current

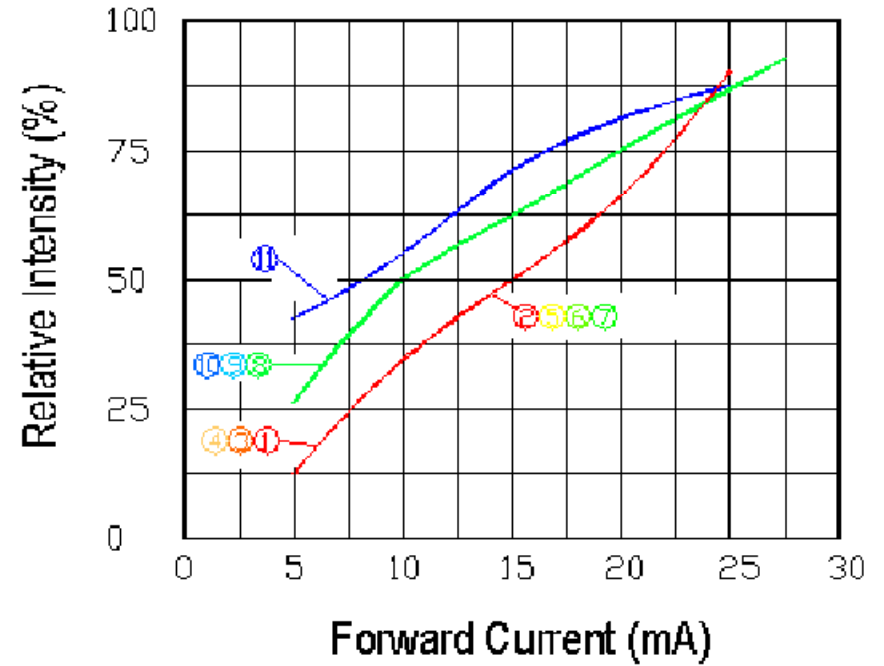

Relative Intensity vs. Forward Current



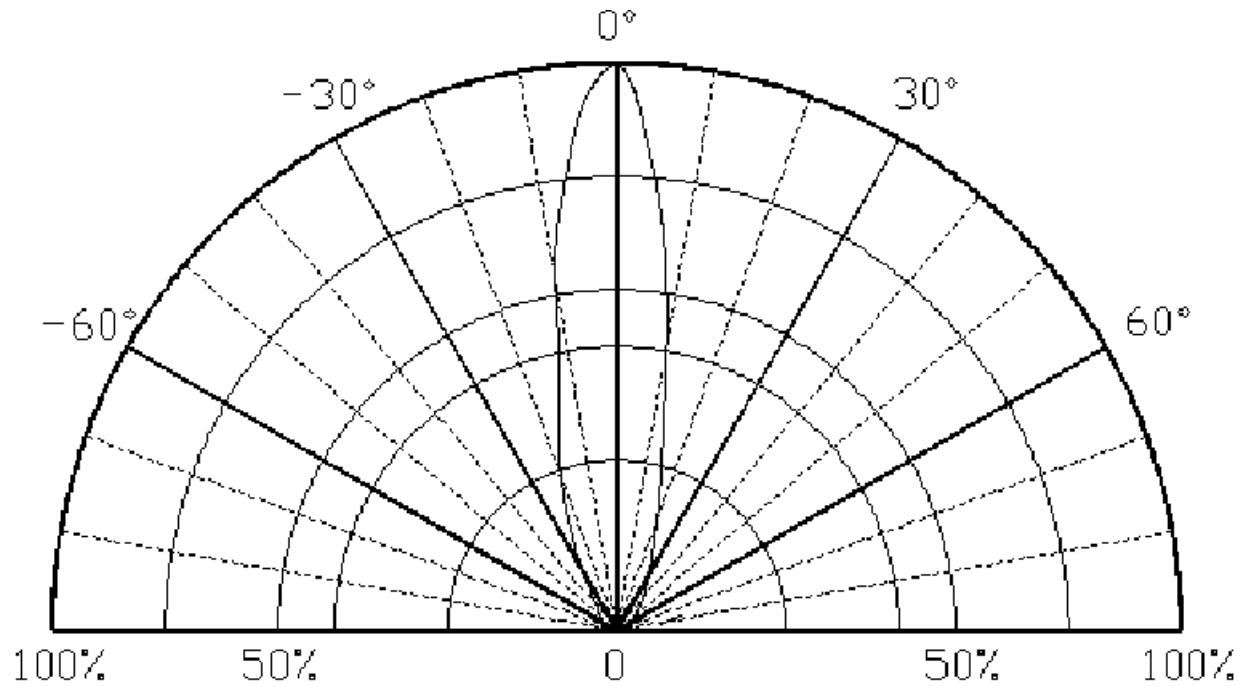

STANDARD TOLERANCE ( UNLESS OTHERWISE SPECIFIED ) ±10% ALL VALUES      ANGULAR X° ± 5°		 4 THOMAS, IRVINE, CA. 92618 TEL: (949) 951-8808    FAX: (949) 951-3974		
				<b>TITLE:</b> SURFACE MOUNT LED, 1.8mm DOMED LENS
DESIGNED: <b>David Green</b>	DATE: <b>10/21/02</b>	<b>PART NO:</b> SM2-XXXX-20	<b>REVISION:</b> H	
CHECKED: <b>M. Chen</b>	DATE: <b>10/21/02</b>		<b>CAGE CODE :</b> 32559	<b>SHEET # 4 OF 6</b>
CAD GENERATED DOCUMENT, DO NOT MEASURE DRAWING.				

REV.	DESCRIPTION	DATE	APPROVED
	SEE SHEET#1.		



### Directive Characteristics

STANDARD TOLERANCE ( UNLESS OTHERWISE SPECIFIED ) ±10% ALL VALUES		ANGULAR X° ± 5°	
		 4 THOMAS, IRVINE, CA. 92618 TEL: (949) 951-8808 FAX: (949) 951-3974	
		 <b>TITLE:</b> SURFACE MOUNT LED, 1.8mm DOMED LENS	
DESIGNED: <b>David Green</b>	DATE: <b>10/21/02</b>	<b>PART NO:</b> SM2-XXXX-20	REVISION: <b>H</b>
CHECKED: <b>M. Chen</b>	DATE: <b>10/21/02</b>	<b>CAGE CODE :</b> 32559	<b>SHEET #</b> 5 OF 6
CAD GENERATED DOCUMENT. DO NOT MEASURE DRAWING.			

REV.	DESCRIPTION	DATE	APPROVED
	See Sheet #1.		

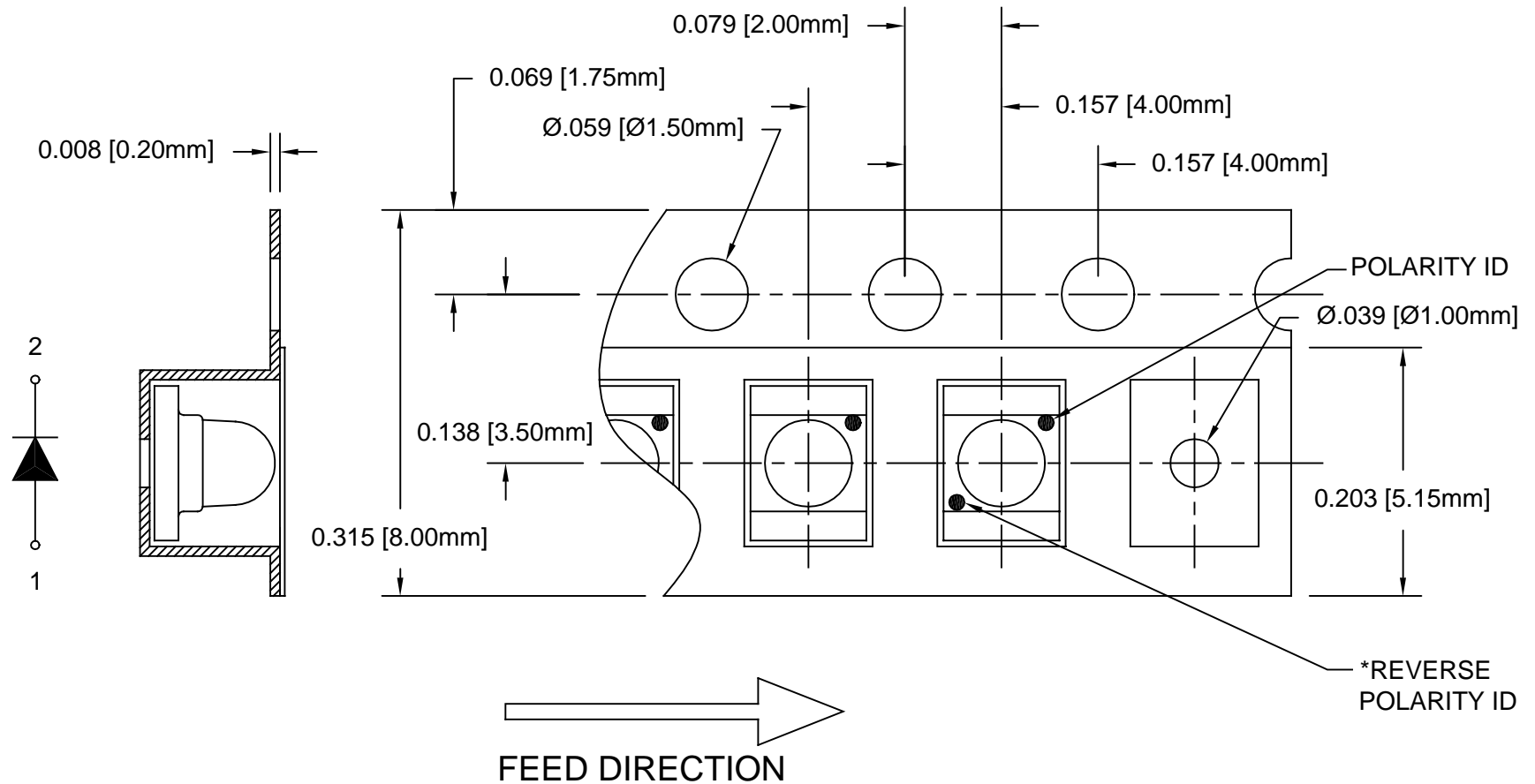

2. UNLESS OTHERWISE SPECIFIED,  
PACKAGING TO COMPLY WITH EIA-481  
1. 1500 pcs PER REEL

STANDARD TOLERANCE ( UNLESS OTHERWISE SPECIFIED )		<b>BIVAR®</b>	
DECIMALS	ANGULAR	4 THOMAS, IRVINE, CA. 92618	
.X ±.1	X° ± 1°	TEL: (949) 951-8808 FAX: (949) 951-3974	
.XX ±.02		<b>TITLE:</b> SURFACE MOUNT LED, 1.8mm DOMED LENS	
.XXX ±.010		<b>PART NO:</b> SM2-XXXX-20	
<b>DESIGNED:</b> David Green	<b>DATE:</b> 10/21/02	<b>REVISION:</b> H	
<b>CHECKED:</b> M. Chen	<b>DATE:</b> 10/21/02	<b>CAGE CODE :</b> 32559 <b>SHEET #</b> 6 OF 6	
CAD GENERATED DOCUMENT, DO NOT MEASURE DRAWING.			

Компания «Life Electronics» занимается поставками электронных компонентов импортного и отечественного производства от производителей и со складов крупных дистрибьюторов Европы, Америки и Азии.

С конца 2013 года компания активно расширяет линейку поставок компонентов по направлению коаксиальный кабель, кварцевые генераторы и конденсаторы (керамические, пленочные, электролитические), за счёт заключения дистрибьюторских договоров

Мы предлагаем:

- Конкуренеспособные цены и скидки постоянным клиентам.
- Специальные условия для постоянных клиентов.
- Подбор аналогов.
- Поставку компонентов в любых объемах, удовлетворяющих вашим потребностям.
- Приемлемые сроки поставки, возможна ускоренная поставка.
- Доставку товара в любую точку России и стран СНГ.
- Комплексную поставку.
- Работу по проектам и поставку образцов.
- Формирование склада под заказчика.
- Сертификаты соответствия на поставляемую продукцию (по желанию клиента).
- Тестирование поставляемой продукции.
- Поставку компонентов, требующих военную и космическую приемку.
- Входной контроль качества.
- Наличие сертификата ISO.

В составе нашей компании организован Конструкторский отдел, призванный помогать разработчикам, и инженерам.

Конструкторский отдел помогает осуществить:

- Регистрацию проекта у производителя компонентов.
- Техническую поддержку проекта.
- Защиту от снятия компонента с производства.
- Оценку стоимости проекта по компонентам.
- Изготовление тестовой платы монтаж и пусконаладочные работы.



Тел: +7 (812) 336 43 04 (многоканальный)

Email: [org@lifeelectronics.ru](mailto:org@lifeelectronics.ru)