

Model 425

Wing Union/Hammer Union Pressure Sensors



DESCRIPTION

Honeywell's Model 425 Wing Union/Hammer Union Pressure Sensors are rugged devices designed for use with Weco® 1502 fittings for both offshore and land-based oil and gas applications.

Available in two accuracy levels [± 0.2 % BFSL (Best Fit Straight Line) - Standard] or (± 0.1 % BFSL - High Accuracy), Model 425 is typically used in demanding applications such as well stimulation and circulation systems. The higher accuracy option at ± 0.1 % full scale provides more confidence in the actual measured pressure value, particularly for smaller changes in pressure, allowing drilling operation adjustments as needed.

Model 425 is constructed as an all-welded, stainless steel assembly with the sensor diaphragm and wing union fitting ma-

chined as one part. This helps ensure hermetic integrity, which lessens the chance of media leakage vs. multi-piece parts, and increases reliability. The isolated, pressure sensing diaphragm minimizes zero-shift during hammer up and eliminates long term, signal drift in the field. The Weco® 1502 (2 in) Wing Union compatible fittings are machined of Inconel® X-750, which provides additional durability with highly abrasive and corrosive media, while the Honeywell proprietary stainless steel electrical connection delivers enhanced secondary pressure containment.

Each sensor undergoes special assembly processes to test shock and vibration for reliable performance in the field.

FEATURES

- ± 0.1 % high accuracy BFSL;
 ± 0.2 % standard accuracy BFSL
- All-welded one-piece, hermetically sealed, stainless-steel construction
- Inconel® X-750 wetted parts for additional durability with abrasive or corrosive media
- Multiple electrical connections
- Optional one-wire (with IS approval) or two-wire (without IS approval) shunt calibration allows users the ability to validate the offset signal in the field, ensuring the sensor is actively plugged into the system
- RFI/EMI protected
- Intrinsically safe
- CE approved; CSA/ATEX certification

POTENTIAL APPLICATIONS

- Acidizing
- Choke manifold
- Fracturing and cementing
- Mud pumps / mud logging
- New well development and extraction
- Oil and gas drilling
- Service and cement trucks
- Standpipe
- Stimulation
- Well head measurement



Model 425

PERFORMANCE SPECIFICATIONS

Characteristic	Measure
Pressure ranges	0 psi to 5000 psi; 0 psi to 6000 psi; 0 psi to 10000 psi; 0 psi to 15000 psi; 0 psi to 20000 psi ³ ; 0 bar to 350 bar; 0 bar to 400 bar; 0 bar to 700 bar; 0 bar to 1000 bar; 0 bar to 1350 bar ³
Accuracy ¹	±0.1 % (total error) best fit straight line ±0.2 % (total error) best fit straight line
Calibration	Standard 5-point calibration: 0 %, 50 %, and 100 % of full scale
Output	4 mA to 20 mA, two-wire
Resolution	Infinite

ENVIRONMENTAL SPECIFICATIONS

Characteristic	Measure
Temperature, operating	-43 °C to 85 °C [-45 °F to 185 °F]*
Temperature, compensating	-34 °C to 82 °C [-30 °F to 180 °F]
Temperature effect, zero	0.018 % full scale/°C [0.01 % full scale/°F]
Temperature effect, span	0.018 % reading/°C [0.01 % reading/°F]
Temperature effect, sealing	Hermetically sealed IP68/NEMA 6P

*Consult the installation guide for T ambient

ELECTRICAL SPECIFICATIONS

Characteristic	Measure
Supply voltage	9 Vdc to 28 Vdc
Insulation resistance	>100 MOhm @ 50 Vdc
Max. loop resistance	950 ohm @ 28 V decreasing linearly to 0 ohm @ 9 V
Circuit protection	Reverse polarity protection of supply leads
RFI/EMI protection	Noise immunity from 5000 Hz to 1 GHz
Frequency response	Customer specified and factory installed filter for frequency response of min. 10 Hz to max. of 2500 Hz
Zero and span adjustment	Field adjustable by removing connector
Electrical termination (std)	Standard electrical termination: MS series compatible, 4 pin, connector designed in stainless steel specifically for the oil and gas industry; offers full hermetic sealing (see pages 3 and 4 for additional electrical terminations)
Shunt calibration	Optional one-wire (with IS approval) or two-wire (without IS approval)

MECHANICAL SPECIFICATIONS

Characteristic	Measure
Media	Corrosive and abrasive service, Inconel® X-750
Overload, safe	150 % rated full scale pressure or limit of Weco® 1502 fitting
Overload, burst	250 % rated pressure or limit of Weco® 1502 fitting
Pressure port	Weco® 1502 wing union, 51 mm [2 in] pipe, male sub end
Wetted parts material	Inconel® X-750
Weight	2722 g [6 lb]
Housing material	316L stainless steel (labels are welded stainless steel with embossed characters)

INTERNAL AMPLIFIERS

Amplifier specifications	Intrinsically safe amp: Option 2n(2N)***
Output signal	4 mA to 20 mA
Input power (voltage)	9 Vdc to 28 Vdc
Input power (current)	4 mA to 24 mA
Frequency response (amp)	2500 Hz
Power supply rejection	60 db
Operating temperature	-43 °C to 85 °C [-45 °F to 185 °F]
Reverse voltage protection	Yes
Short circuit protection	Yes
Wiring code: connector (std)	A No connection B (+) Output C (+) Supply D Case ground

*** See Honeywell's Web site (<http://measurementsensors.honeywell.com>) for the most up-to-date information regarding intrinsically safe approvals, ref. #008-0547-00.

Wing Union/Hammer Union Pressure Sensors

LISTINGS

Order code	Description
BP425DR,5,1AC,2N,6Z,7AD,10E	Model 425, 5,000 psi, ±0.1% accuracy BFSL, -35 °C to 80 °C [-30 °F to 180 °F] temperature compensation, 4 mA to 20 mA two-wire intrinsically safe, MS compatible, 4-pin connector, wetted diaphragm
BP425NG,6,1AC,2N,6Z,7AD,10E	Model 425, 350 bar, ±0.2% accuracy BFSL, -35 °C to 80 °C [-30 °F to 180 °F] temperature compensation, 4 mA to 20 mA two-wire intrinsically safe, MS compatible, 4-pin connector, wetted diaphragm
BP425DV,5,1AC,2N,6Z,7AD,10E	Model 425, 10,000 psi, ±0.1% accuracy BFSL, -35 °C to 80 °C [-30 °F to 180 °F] temperature compensation, 4 mA to 20 mA two-wire intrinsically safe, MS compatible, 4-pin connector, wetted diaphragm
BP425MN,5,1AC,2N,6Z,7AD,10E	Model 425, 1,000 bar, ±0.1% accuracy BFSL, -35 °C to 80 °C [-30 °F to 180 °F] temperature compensation, 4 mA to 20 mA two-wire intrinsically safe, MS compatible, 4-pin connector, wetted diaphragm
BP425EJ,6,1AC,2N,6Z,7AD,10E	Model 425, 15,000 psi, ±0.2% accuracy BFSL, -35 °C to 80 °C [-30 °F to 180 °F] temperature compensation, 4 mA to 20 mA two-wire intrinsically safe, MS compatible, 4-pin connector, wetted diaphragm

ORDER CODE NOMENCLATURE

Combine the order code, range code, and options code.

BP425 **EJ**, **6, 1AC, 2N, 6Z, 7AD, 10E**

Order code Range code Options code

BP425	EJ	6	1AC	2N	Amplifier Enhancements	6Z	7AD	Calibration Options	10E
Pressure Type	Range (Gauge)	Accuracy	Temperature Compensation	Internal Amplifiers	Amplifier Enhancements	Electrical Termination	Wiring Code Options	Calibration Options	Material Type
BP 425	DR 5000 psi	5 ±0.1 % BFSL	1AC -35 °C to 80 °C [-30 °F to 180 °F]	2N 4 mA to 20 mA two wire, intrinsically safe	None	6A Bendix PT, 6-pin shell size 10 conn PTH-10-6P	7AD 4-Pin Standard A: N/C or Shunt; B: + Out; C: + Supply; D: Case Ground	None	10E Wetted diaphragm
	DS 6000 psi	6 ±0.2 % BFSL		2Y CE approved 4 mA to 20 mA two wire	3D Remote buffered one-wire shunt calibration	6Z MS series comp. 4 pin, shell size 14 connector (32A-14S-2P-10-MZ)	7AE 4-Pin Jupiter A: N/C; B: Case Ground; C: + Out; D: + Supply	9A Special cal., 10 point	
	DV 10000 psi				3H 4 mA to 16 mA 2-wire IS with over-range fdbk	6BF Jupiter 4-pin	7AF 6-Pin Standard A: + Supply; B: + Out; C: N/C; D: Case Ground; E: N/C or Shunt; F: N/C	9B Special cal., 20 point	
	EJ 15000 psi				3J Remote buffered two-wire shunt calibration	6BG Jupiter 7-pin	7AG 7-Pin Jupiter A: N/C; B: N/C; C: N/C; D: + Supply; E: + Out; F: Case Ground; G: N/C or Shunt		
	EL 20000 psi ³				3K 4 mA to 16 mA 2-wire shunt cal. over-range fdbk	6BH Rota B-Series 4-pin	7AH 6-Pin Standard A: + Supply; B: - Supply; C: N/C; D: Case Ground; E: + Shunt Cal; F: - Shunt Cal		
	NG 350 bar								
	NN 400 bar								
	NH 700 bar								
	MN 1000 bar								
	NU 1350 bar ³								

Exceptions:

Option 7AD can only be used with Options 6Z or 6BF or 6BH

Option 7AE can only be used with Option 6BF

Option 7AF can only be used with Option 6A

Option 7AG can only be used with Option 6BG

Option 3D cannot be used with Options (7AE and 6BF)

Option 3J can only be used with Option 2Y

Options EJ + 3H can give 20000 psi [1350 bar] pressure reading

Two-wire shunt cal is not IS approved.

Model 425

RANGE CODES

Range Code	Available ranges
DR	0 psi to 5000 psi
DS	0 psi to 6000 psi
DV	0 psi to 10000 psi
EJ	0 psi to 15000 psi
see note#3 on page 4	0 psi to 20000 psi ³
NG	0 bar to 350 bar
NN	0 bar to 400 bar
NH	0 bar to 700 bar
MN	0 bar to 1000 bar
see note#3 on page 4	0 bar to 1350 bar ³

MOUNTING DIMENSIONS

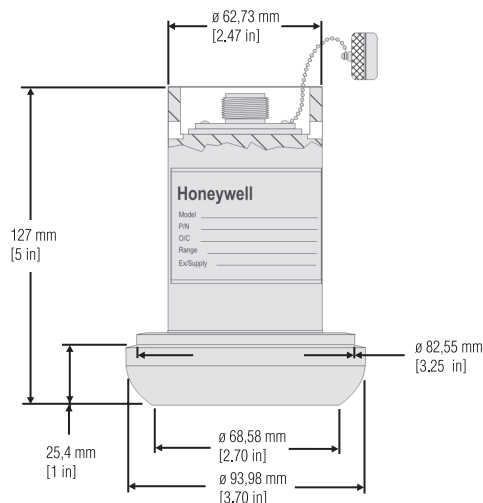

For reference only

NOTES

1. Accuracies stated are expected for best fit straight line for all errors including linearity, hysteresis and non-repeatability thru zero.
2. Availability varies with range.
3. Working pressure and approval limited to 15000 psi [1000 bar]. Amplifier enhancement option 3H will allow overpressure reading to 20000 psi [1350 bar]. When ordering, use EJ + 3H or MN + 3H in the order code.



SPECIAL REQUIREMENTS (CONSULT FACTORY)

Need a special modification or complete custom design to meet your unique requirements? Consult our factory by calling +1 614-850-5000 (800-848-6564) or visit us online at <http://measurementsensors.honeywell.com>.

OPTION CODES

Pressure Ranges	0 psi to 5000 psi; 0 psi to 6000 psi; 0 psi to 10000 psi; 0 psi to 15000 psi; 0 psi to 20000 psi ³ ; 0 bar to 350 bar; 0 bar to 400 bar; 0 bar to 700 bar; 0 bar to 1000 bar; 0 bar to 1350 bar ³
Temperature Compensation	-34 °C to 82 °C [-30 °F to 180 °F]
Internal Amplifier	2N. 4 mA to 20 mA, two-wire output; intrinsically safe 2Y. CE approved 4 mA to 20 mA two-wire
Accuracy	5. ±0.1 % BFSL 6. ±0.2 % BFSL
Electrical Termination	Standard electrical termination: MS series compatible, 4 pin, connector designed in stainless steel specifically for the oil and gas industry; offers full hermetic sealing 6A. Bendix PT, 6-pin shell size 10 conn, PTIH-10-6P (max. 121 °C [250 °F]) 6Z. MS series compatible, 4 pin, shell size 14 connector (32A-14S-2P-10-M2) 6BF. Jupiter 4-pin connection 6BG. Jupiter 7-pin connection 6BH. Rota B-Series 4-pin Other connection(s) - By request
Amplifier Enhancements	3D. Remote buffered shunt calibration 3H. 4 mA to 16 mA two-wire IS with over-range feedback; will read 20 mA @ 20000 psi 3J. Remote buffered two-wire shunt calibration 3K. 4 mA to 16 mA two-wire shunt calibration with over-range feedback
Special Calibration²	9A. 10 point (5 up/5 down) 20 % increments @ 21 °C [70 °F] 9B. 20 point (10 up/10 down) 10 % increments @ 21 °C [70 °F]
Wetted Diaphragm	10E. Inconel® X-750

WIRING CODE OPTIONS

Order Code	Wiring
7AD	4 Pin Standard A: N/C or Shunt; B: + Out; C: + Supply; D: Case Ground
7AE	4 Pin Jupiter A: N/C; B: Case Ground; C: + Out; D: + Supply
7AF	6 Pin Standard A: + Supply; B: + Out; C: N/C; D: Case Ground E: N/C or Shunt; F: N/C
7AG	7 Pin Standard A: N/C; B: N/C; C: N/C; D: + Supply; E: + Out F: Case Ground; G: N/C or Shunt
7AH	6 Pin Standard A: + Supply; B: - Supply; C: N/C; D: Case Ground E: + Shunt Cal; F: - Shunt Cal

Option 7AD can only be used with Options 6Z or 6BF or 6BH

Option 7AE can only be used with Option 6BF

Option 7AF can only be used with Option 6A

Option 7AG can only be used with Option 6BG

Option 3D cannot be used with Options (7AE and 6BF)

Option 3J can only be used with Option 2Y

Model 425

Wing Union/Hammer Union Pressure Sensor

Warranty. Honeywell warrants goods of its manufacture as being free of defective materials and faulty workmanship. Honeywell's standard product warranty applies unless agreed to otherwise by Honeywell in writing; please refer to your order acknowledgement or consult your local sales office for specific warranty details. If warranted goods are returned to Honeywell during the period of coverage, Honeywell will repair or replace, at its option, without charge those items it finds defective. **The foregoing is buyer's sole remedy and is in lieu of all warranties, expressed or implied, including those of merchantability and fitness for a particular purpose. In no event shall Honeywell be liable for consequential, special, or indirect damages.**

While we provide application assistance personally, through our literature and the Honeywell web site, it is up to the customer to determine the suitability of the product in the application.

Specifications may change without notice. The information we supply is believed to be accurate and reliable as of this printing. However, we assume no responsibility for its use.

WARNING

PERSONAL INJURY

- DO NOT USE these products as safety or emergency stop devices or in any other application where failure of the product could result in personal injury.

Failure to comply with these instructions could result in death or serious injury.

WARNING

MISUSE OF DOCUMENTATION

- The information presented in this datasheet is for reference only. DO NOT USE this document as product installation information.
- Complete installation, operation and maintenance information is provided in the instructions supplied with each product.

Failure to comply with these instructions could result in death or serious injury.

Find out more

Honeywell serves its customers through a worldwide network of sales offices, representatives and distributors. For application assistance, current specifications, pricing or name of the nearest Authorized Distributor, contact your local sales office. To learn more about Honeywell's test and measurement products, call **+1-614-850-5000**, visit **measurementsensors.honeywell.com**, or e-mail inquiries to **info.tm@honeywell.com**

Sensing and Control
Honeywell
1985 Douglas Drive North
Golden Valley, MN 55422
www.honeywell.com

Honeywell

008682-6-EN IL50 GLO
November 2012

Copyright © 2012 Honeywell International Inc. All rights reserved.

® Inconel is a registered trademark of Inco Alloys International, Inc.

® Weco is registered trademark of Fmc Corporation; Glenair is a registered trademark of Glenair, Inc.

Компания «Life Electronics» занимается поставками электронных компонентов импортного и отечественного производства от производителей и со складов крупных дистрибьюторов Европы, Америки и Азии.

С конца 2013 года компания активно расширяет линейку поставок компонентов по направлению коаксиальный кабель, кварцевые генераторы и конденсаторы (керамические, пленочные, электролитические), за счёт заключения дистрибьюторских договоров

Мы предлагаем:

- Конкуренспособные цены и скидки постоянным клиентам.
- Специальные условия для постоянных клиентов.
- Подбор аналогов.
- Поставку компонентов в любых объемах, удовлетворяющих вашим потребностям.
- Приемлемые сроки поставки, возможна ускоренная поставка.
- Доставку товара в любую точку России и стран СНГ.
- Комплексную поставку.
- Работу по проектам и поставку образцов.
- Формирование склада под заказчика.
- Сертификаты соответствия на поставляемую продукцию (по желанию клиента).
- Тестирование поставляемой продукции.
- Поставку компонентов, требующих военную и космическую приемку.
- Входной контроль качества.
- Наличие сертификата ISO.

В составе нашей компании организован Конструкторский отдел, призванный помогать разработчикам, и инженерам.

Конструкторский отдел помогает осуществить:

- Регистрацию проекта у производителя компонентов.
- Техническую поддержку проекта.
- Защиту от снятия компонента с производства.
- Оценку стоимости проекта по компонентам.
- Изготовление тестовой платы монтаж и пусконаладочные работы.



Тел: +7 (812) 336 43 04 (многоканальный)

Email: org@lifeelectronics.ru