

HOLD DOWN TYPE



FCIconnect.com

Copyright FCI

| | | | | | | | | | | | | |
|-------------|----------------|----|-----------|---------------------------------------|---|-----------------------|---|----------------|--|----------------------------|--|--|
| mat'l. code | | | | surface 58/ISO 1302 | | tolerance ISO 406 ISO | | projection 101 | | product family PCI_EXPRESS | | |
| ltr | ecn no | dr | date | tolerances unless otherwise specified | | angles linear | | MM | | title | | |
| A | T04-0004 | RC | 02/05/'07 | | | | | | | PCI_EXPRESS_CARD_EDGE | | |
| B | T07-1083 | RC | 05/25/'07 | | | | | | | POST-FREE_ASSEMBLY(SMT) | | |
| C | DG-007885 | HT | 11/14/'11 | 0'±2' | | | | scale 1 | | dwg no sheet 1 of 6 size | | |
| D | DG-009560 | HT | 01/16/'12 | dr RICHARD_CHIU | | 01/30/'07 | | FCI | | 10076266 A4 | | |
| E | ELX-DG-13973 | WL | 01/31/'13 | enr RICHARD_CHIU | | 01/30/'07 | | | | type CUSTOMER Drawing | | |
| | | | | chr PAUL_WANG | | 01/30/'07 | | | | | | |
| | | | | app JOSEPH_HSIA | | 01/30/'07 | | | | | | |
| sheet index | revision sheet | E | A | A | E | A | A | | | | | |
| | | 1 | 2 | 3 | 4 | 5 | 6 | | | | | |



← I/O PANEL DIRECTION
PRIMARY (COMPONENT) SIDE



I/O PANEL DIRECTION →
SECONDARY (SOLDER) SIDE

| # | POS | REF. | N | DIM "G" | DIM "F" | "F" |
|-----|-----|------|-------|---------|---------|-----|
| 36 | 6 | | 8.15 | 6.00 | B17 | |
| 64 | 20 | | 22.15 | 20.00 | B31 | |
| 98 | 37 | | 39.15 | 37.00 | B48 | |
| 164 | 70 | | 72.15 | 70.00 | B81 | |

PIN "F" SEE TABLE

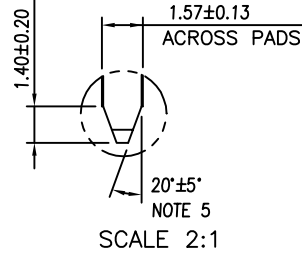

ADD-IN CARD EDGE-FINGER DIMENSIONS

| | | | | | | | | | | | |
|-------------|--|----------|--|------------|--|-----------------------|--|------------|--|--|--|
| mat'l. code | | | | surface 58 | | tolerance | | projection | | product family | |
| - | | | | ISO 1302 | | ISO 406 ISO 101 | | | | PCI_EXPRESS | |
| ltr | | | | ecn no | | dr | | date | | title | |
| A | | | | - | | - | | - | | PCI_EXPRESS_CARD_EDGE POST-FREE_ASSEMBLY(SMT) | |
| | | | | angles | | linear | | MM | | dwg no | |
| | | | | 0°±2' | | .XX±.13 | | | | sheet 2 of 6 | |
| | | | | .XXX±.05 | | scale 2 | | | | size | |
| | | | | dr | | RICHARD_CHIU 1/30/'07 | | 10076266 | | A4 | |
| | | | | enr | | RICHARD_CHIU 1/30/'07 | | type | | CUSTOMER Drawing | |
| | | | | chr | | PAUL_WANG 1/30/'07 | | | | | |
| | | | | app | | JOSEPH_HSIA 1/30/'07 | | | | | |
| sheet index | | revision | | A | | | | | | | |
| | | sheet | | 2 | | | | | | | |



Copyright FCI

FCIconnect.com



RECOMMENDED PCB LAYOUT, PAD TYPE

| DIMENSIONS | | | | | | | |
|------------|-------|-------------------------|--------------|--------------|--------------|--------------|-------|
| POSITION | A | B ± 0.15 -0.05 | C ± 0.20 | D ± 0.23 | E ± 0.20 | H ± 0.10 | J |
| 36 | 6.00 | 7.65 | 9.15 | 25.00 | 27.00 | 28.00 | 6.00 |
| 64 | 20.00 | 21.65 | 23.15 | 39.00 | 41.00 | 42.00 | 20.00 |
| 98 | 37.00 | 38.65 | 40.15 | 56.00 | 58.00 | 59.00 | 37.00 |
| 164 | 70.00 | 71.65 | 73.15 | 89.00 | 91.00 | 92.00 | 70.00 |

POSITION OF CAP

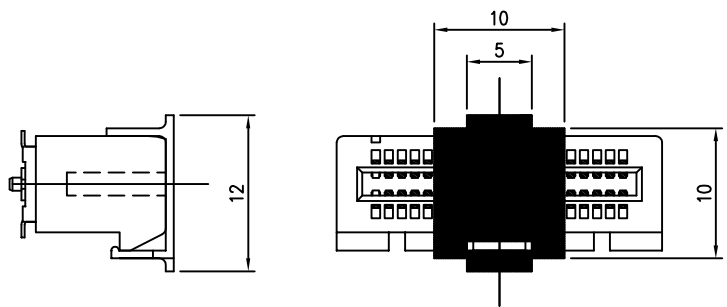

FCI
FCIconnect.com

| | | | | | | | | | | | | | |
|-------------|----------------|----|------|---------------------------------------|--------------|------------------|--|------------|----------|-------------------------|------------------|--------------|------|
| mat'l. code | | | | surface 58 | | tolerance | | projection | | product family | | | |
| - | | | | ISO 1302 \checkmark | | ISO 406 ISO 1101 | | | | PCI_EXPRESS | | | |
| ltr | ecn no | dr | date | tolerances unless otherwise specified | | | | | | title | | | |
| A | - | - | - | angles | | .X \pm .2 | | MM | | PCI_EXPRESS_CARD_EDGE | | | |
| | | | | linear | | .XX \pm .13 | | | | POST-FREE_ASSEMBLY(SMT) | | | |
| | | | | 0 $^{\circ}$ \pm 2 $^{\circ}$ | | XXX \pm .05 | | scale 2 | | dwg no | | sheet 3 of 6 | size |
| | | | | dr | RICHARD_CHIU | 1/30/'07 | | | 10076266 | | A4 | | |
| | | | | engr | RICHARD_CHIU | 1/30/'07 | | | type | | CUSTOMER Drawing | | |
| | | | | chr | PAUL_WANG | 1/30/'07 | | | | | | | |
| | | | | appd | JOSEPH_HSIA | 1/30/'07 | | | | | | | |
| sheet index | revision sheet | A | 3 | | | | | | | | | | |

Copyright FCI

NOTES:

1.MATERIAL:

HOUSING: NYLON, GLASS FILLED UL94V-0 RATE, SUITABLE FOR IR SOLDERING.

TERMINAL: COPPER ALLOY

PLATING: 50u" NICKEL UNDERPLATE ALL OVER
CONTACT AREA PLATING - SEE PRODUCT NUMBER CODE
SOLDER TAIL: TIN 100u" OVER 50u" NICKEL

METAL PADS: COPPER ALLOY
FINISH: 100u" TIN OVER 50u" NICKEL

2.PRODUCT SPECIFICATION: GS-12-390

③THE HORIZONTAL AXIS FOR THE PAD PATTERN IS ESTABLISHED BY THE CENTER LINE OF THE PAD LENGTH.
THE VERTICAL AXIS IS 90° TO THE HORIZONTAL AXIS, THROUGH THE CENTER OF DATUM [Z-]

④NO TIE BAR PERMITTED FROM CARD EDGE TO LEADING EDGE OF PAD FOR PINS A1.

⑤CHAMFER EDGES MUST BE FREE OF CUTTING BURRS.

7.RoHS COMPATIBLE PRODUCT SPECIFICATIONS

a - PLATING:

- "LF" MEANS THE PRODUCT IS LEAD-FREE, 2um MINIMUM MATTE TIN OVER 1.27um MINIMUM NICKEL UNDERPLATE.

b - MANUFACTURING PROCESS COMPATIBILITY

- THE HOUSING WILL WITHSTAND EXPOSURE TO 260°C±5°C PEAK TEMPERATURE FOR 5 SECONDS IN A CONVECTION, INFRA-RED OR VAPOR PHASE REFLOW OVEN.

PRODUCT NUMBER CODE

10076266 -X X X X L F

HOUSING COLOR OPTIONS

1-BLACK

LEAD FREE

PACKAGING OPTIONS

- T-TRAY PACKAGING WITHOUT CAP
- R-TAPE & REEL PACKING WITHOUT CAP (FOR 36P&64P OPTIONS ONLY)
- P-TAPE & REEL PACKING WITH CAP (FOR 36P&64P OPTIONS ONLY)
- C-TRAY PACKAGING WITH CAP
- M-TAPE&REEL WITH MYLAR(36P&64P OPTION ONLY)
- F-HARD TRAY PACKAGING WITH CAP (164P ONLY)

TERMINAL PLATING OPTIONS

- 0-50u" Ni UNDERPLATE
30u" Au CONTACT AREA
100u" TIN TAIL AREA ----- COMPATIBLE RoHS
- 1-50u" Ni UNDERPLATE
15u" Au CONTACT AREA
100u" TIN TAIL AREA ----- COMPATIBLE RoHS
- 2-50u" Ni UNDERPLATE
GOLD FLASH CONTACT AREA
100u" TIN TAIL AREA ----- COMPATIBLE RoHS

POS OPTIONS

- 0-36
- 1-64
- 2-98
- 3-164



Copyright FCI

| | | | | | | | | | | | | | | |
|-------------|----------|----|------|---------------------------------------|--|-----------------------|--|------------|--|-------------------------|--|------------------|------|--|
| mat'l. code | | | | surface 58/ISO 1302 | | tolerance ISO 406 ISO | | projection | | product family | | | | |
| - | | | | ISO 1302 | | ISO 406 ISO | | 101 | | PCI_EXPRESS | | | | |
| ltr | ecn no | dr | date | tolerances unless otherwise specified | | angles | | linear | | title | | | | |
| E | - | - | - | .X±.2 | | 0°±2' | | MM | | PCI_EXPRESS_CARD_EDGE | | | | |
| | | | | .XX±.13 | | | | scale 2 | | POST-FREE_ASSEMBLY(SMT) | | | | |
| | | | | XXX±.05 | | | | | | dwg no | | sheet 4 of 6 | size | |
| | | | | dr RICHARD_CHIU 1/30/'07 | | | | FCI | | 10076266 | | A4 | | |
| | | | | enr RICHARD_CHIU 1/30/'07 | | | | | | type | | CUSTOMER Drawing | | |
| | | | | chr PAUL_WANG 1/30/'07 | | | | | | | | | | |
| | | | | app JOSEPH_HSIA 1/30/'07 | | | | | | | | | | |
| sheet index | revision | C | | | | | | | | | | | | |
| | sheet | 4 | | | | | | | | | | | | |

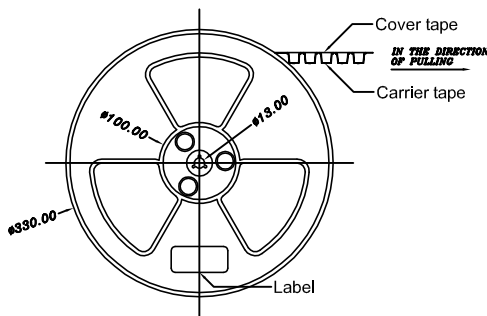
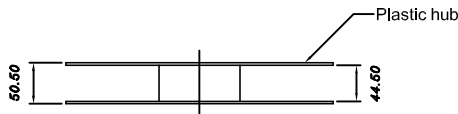
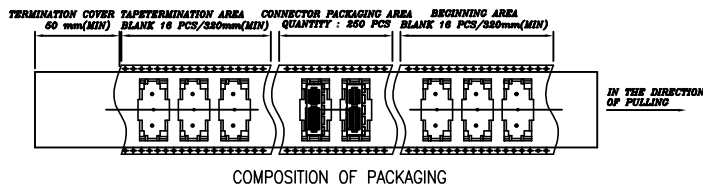
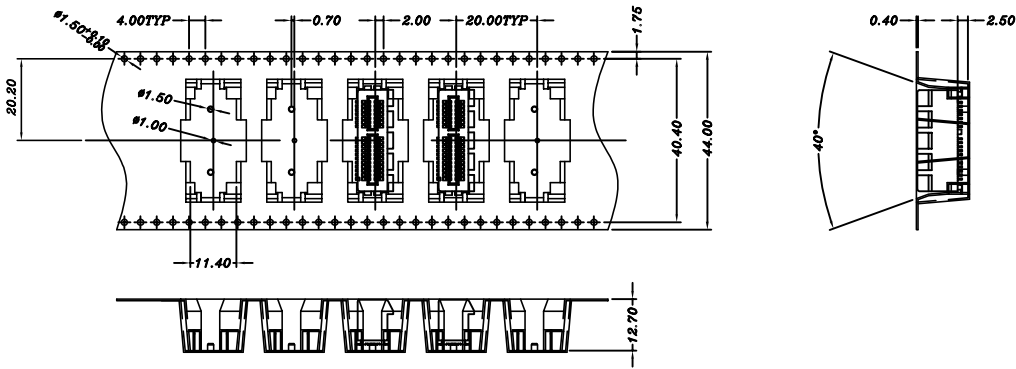

TAPE AND REEL
PACKING
RECOMMENDED FOR
36PINS ONLY

| | | | | | | | | | | | | |
|-------------|----------------|----|------|---------------------------------------|-----------------------|-----------------|---------|------------|-------------------------|----------------|------------------|--|
| mat'l. code | | | | surface 58 | | tolerance | | projection | | product family | | |
| - | | | | ISO 1302 | | ISO 406 ISO 101 | | | | PCI_EXPRESS | | |
| ltr | ecn no | dr | date | tolerances unless otherwise specified | | | | title | | | | |
| A | - | - | - | angles | .X±.3 | | MM | | PCI_EXPRESS_CARD_EDGE | | | |
| | | | | linear | .XX±.20 | | ←→ | | POST-FREE_ASSEMBLY(SMT) | | | |
| | | | | 0°±2' | XXX±.10 | | scale 1 | | dwg no | | | |
| | | | | dr | RICHARD_CHIU 1/30/'07 | | | | sheet 5 of 6 | | size | |
| | | | | engr | RICHARD_CHIU 1/30/'07 | | | | 10076266 | | A4 | |
| | | | | chr | PAUL_WANG 1/30/'07 | | | | type | | CUSTOMER Drawing | |
| | | | | appd | JOSEPH_HSIA 1/30/'07 | | | | | | | |
| sheet index | revision sheet | A | 5 | | | | | | | | | |

1 For PCI EXPRESS SMT TYPE 36P ONLY.

2. Material :

- 2.1 Reel :
 - 2.1.1 Plastic hub : High Impact Polystyrene
 - 2.1.2 Cover tape : PE
 - 2.1.3 Carrier tape : ABS
- 2.2 Waterproof bag : PE
- 2.3 Desiccative : Silica Gel
- 2.4 Carton : Corrugated paper
- 2.5 Baffle : E.P.E
- 2.6 Angle paperboard : Corrugated paper

3. Dimension :

- 3.1 Reel :
 - 3.1.1 Plastic hub : $\phi 330 \times T50.5$ mm
 - 3.1.2 Cover tape : $5690(L) \times 37.4(W)$ mm
 - 3.1.3 Carrier tape : $5640(L) \times 44(W)$ mm
- 3.2 Waterproof bag : $600(H) \times 465(W) \times 0.06(T)$ mm
- 3.3 Desiccative : 25 gram / Package
- 3.4 Carton : $380(L) \times 380(W) \times 300(H)$ mm
- 3.5 Baffle (1): $370(L) \times 370(W) \times 15(H)$ mm
- 3.6 Baffle (2): $355(L) \times 252(W) \times 15(H)$ mm
- 3.7 Angle paperboard : 252(H)

4. Quantity :

- 4.1 250 Pcs / Reel
- 4.2 1250 Pcs / Carton

5. Weight :

- 5.1 NW :
- 5.2 G/W :



A A
B B
C C



| | | | | | | | | | | |
|-------------|----------------|--|--------------|---------------------------------------|---------------|------------|----------|-----------------------|--|------|
| mat'l. code | | surface 58 | | tolerance | | projection | | product family | | |
| - | | ISO 1302 <input checked="" type="checkbox"/> | | ISO 406 ISO 1101 | | | | PCI_EXPRESS | | |
| ltr | ecn no | dr | date | tolerances unless otherwise specified | | | | title | | |
| A | - | - | - | angles | .X \pm .3 | | MM | | PCI_EXPRESS_CARD_EDGE POST-FREE_ASSEMBLY(SMT) | |
| | | | | linear | .XX \pm .20 | | ← → | | | |
| | | | | 0'±2' | XXX±.10 | | scale 1 | | | |
| | | dr | RICHARD_CHIU | 1/30/'07 | | | dwg no | | sheet 6 of 6 | size |
| | | engr | RICHARD_CHIU | 1/30/'07 | | | 10076266 | | A4 | |
| | | chr | PAUL_WANG | 1/30/'07 | | | | | | |
| | | appd | JOSEPH_HSIA | 1/30/'07 | | | | | | |
| sheet index | revision sheet | A | 6 | | | | | type CUSTOMER Drawing | | |

D D

Компания «Life Electronics» занимается поставками электронных компонентов импортного и отечественного производства от производителей и со складов крупных дистрибьюторов Европы, Америки и Азии.

С конца 2013 года компания активно расширяет линейку поставок компонентов по направлению коаксиальный кабель, кварцевые генераторы и конденсаторы (керамические, пленочные, электролитические), за счёт заключения дистрибьюторских договоров

Мы предлагаем:

- Конкурентоспособные цены и скидки постоянным клиентам.
- Специальные условия для постоянных клиентов.
- Подбор аналогов.
- Поставку компонентов в любых объемах, удовлетворяющих вашим потребностям.
- Приемлемые сроки поставки, возможна ускоренная поставка.
- Доставку товара в любую точку России и стран СНГ.
- Комплексную поставку.
- Работу по проектам и поставку образцов.
- Формирование склада под заказчика.
- Сертификаты соответствия на поставляемую продукцию (по желанию клиента).
- Тестирование поставляемой продукции.
- Поставку компонентов, требующих военную и космическую приемку.
- Входной контроль качества.
- Наличие сертификата ISO.

В составе нашей компании организован Конструкторский отдел, призванный помогать разработчикам, и инженерам.

Конструкторский отдел помогает осуществить:

- Регистрацию проекта у производителя компонентов.
- Техническую поддержку проекта.
- Защиту от снятия компонента с производства.
- Оценку стоимости проекта по компонентам.
- Изготовление тестовой платы монтаж и пусконаладочные работы.



Тел: +7 (812) 336 43 04 (многоканальный)
Email: org@lifeelectronics.ru