

LOC	DIST	REVISIONS					
GP	00	P	LTN	DESCRIPTION	DATE	DWN	APVD
		A		RELEASE PER ECO-16-001264	1FEB2016	RG	SH
		B		REVISE PER ECO-17-008876	3AUG2017	RG	SH

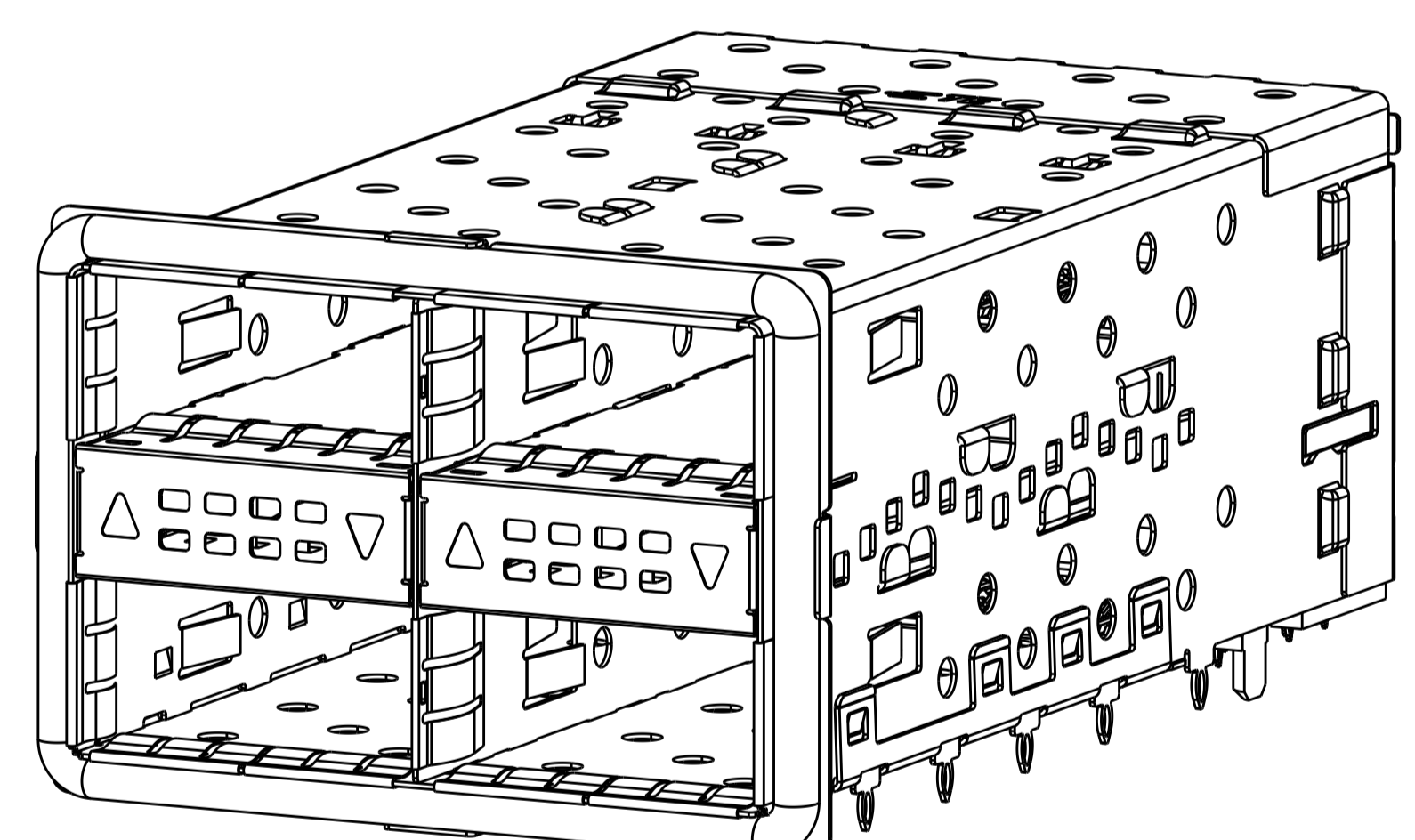
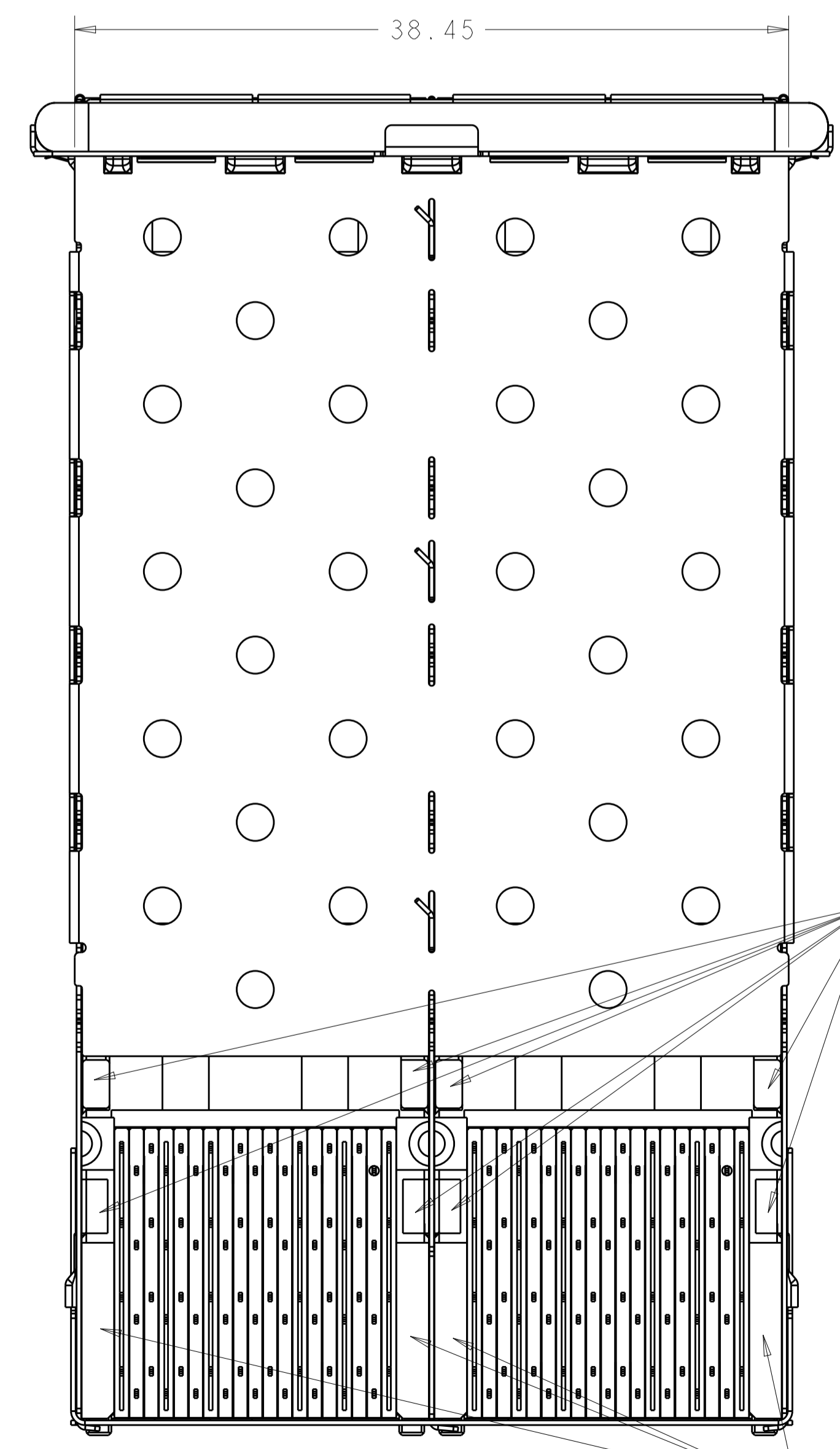
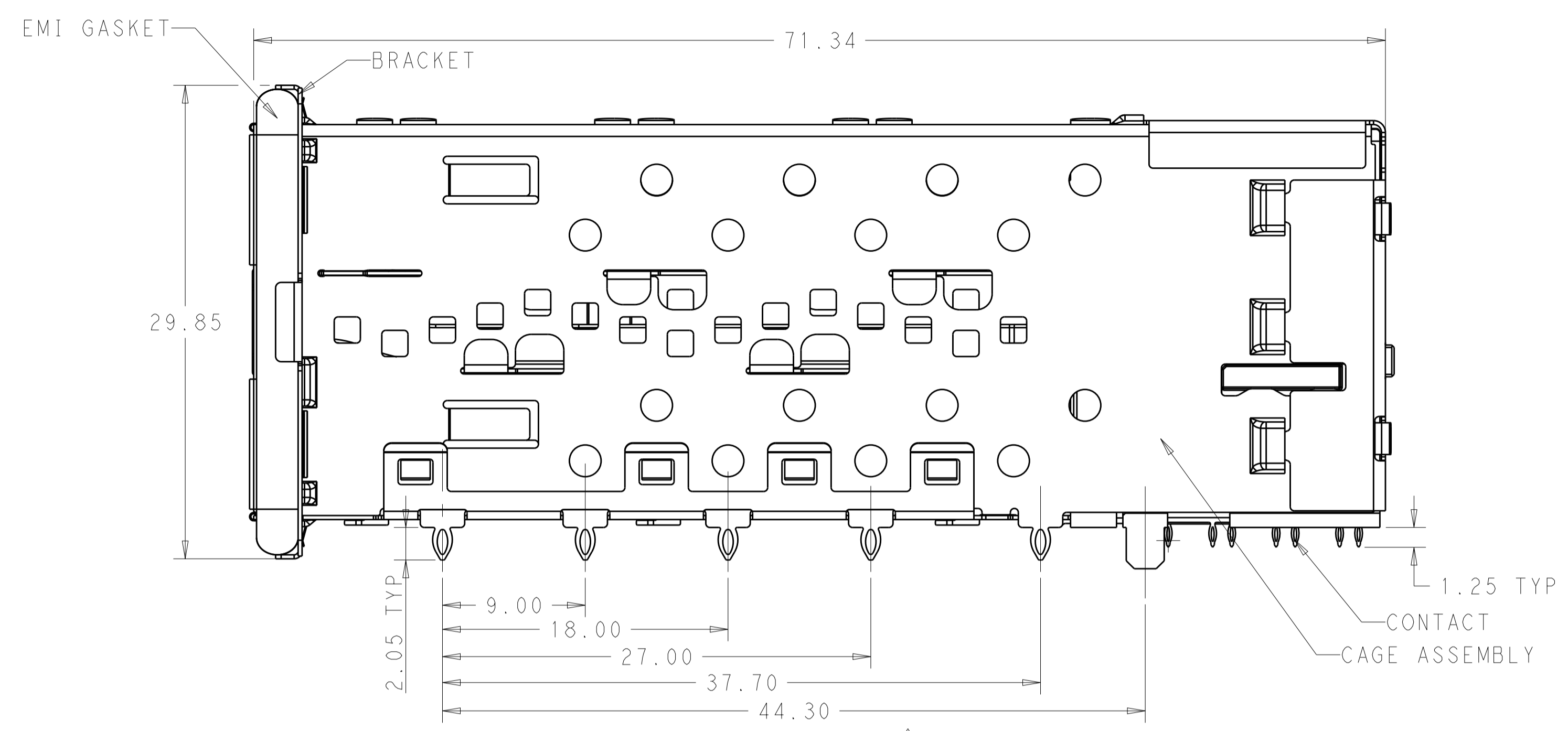
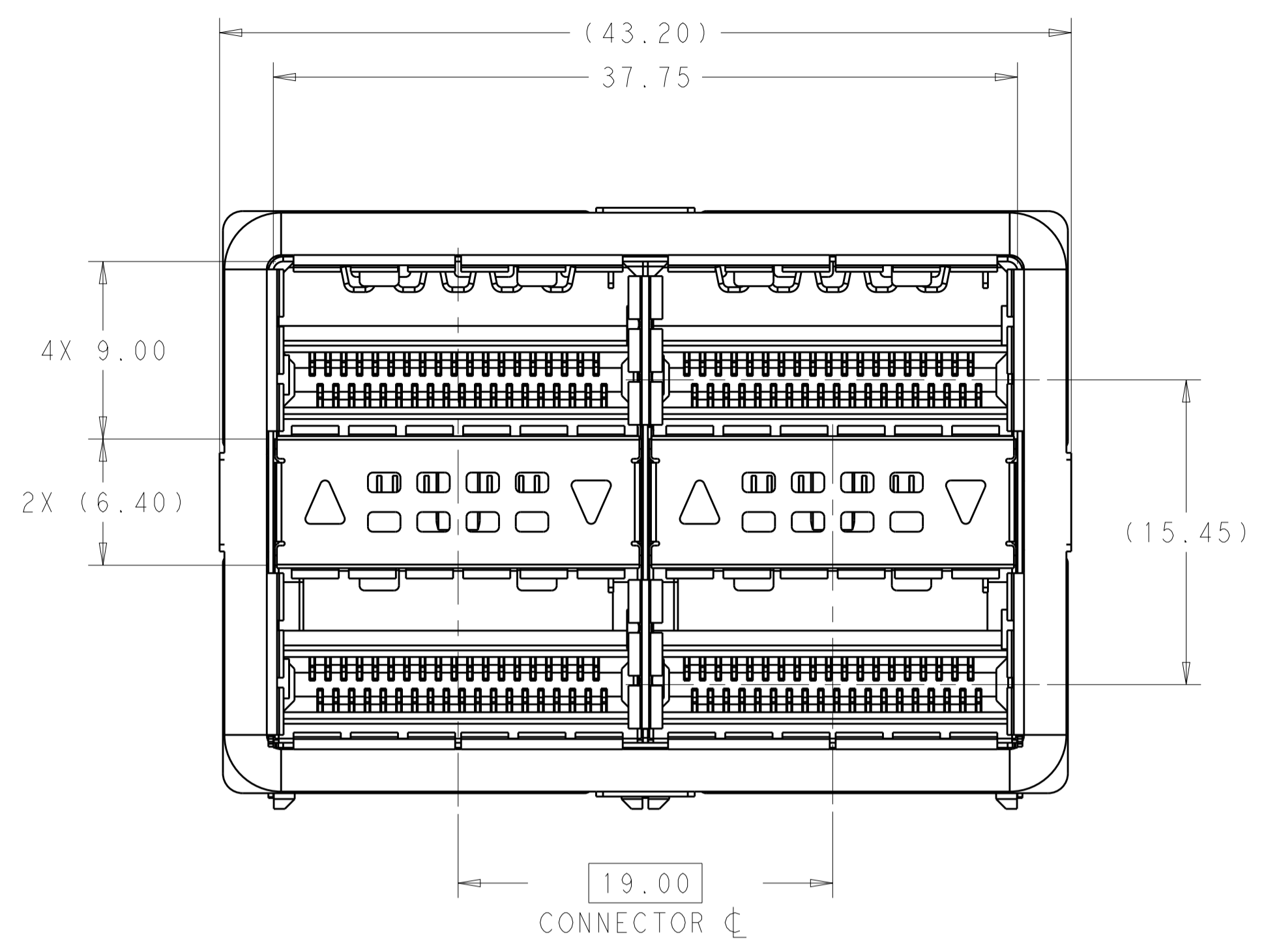

SCALE 3:1

- 1 MATERIAL:
 CAGE ASSEMBLY- STAINLESS STEEL.
 BRACKET- STAINLESS STEEL.
 EMI GASKET- NIKCEL-GRAPHITE FILLED SILICONE.
 HOUSING- BLACK LCP,UL 94V-0 RATED
 CHICKLET- BLACK LCP,UL 94V-0 RATED
 LIGHT PIPE- POLYCARBONATE, CLEAR, UL 94V-0 RATED
 CONTACT- COPPER ALLOY.
 GASKET - CONDUCTIVE RUBBER, UL 94V-0 RATED
- 2 DATUM AND BASIC DIMENSIONS ESTABLISHED BY CUSTOMER.
- 3. MINIMUM PCB THICKNESS OF 1.57mm.
- 4 CONTACT FINISH- CONFORMS TO THE REQUIREMENTS OF TE PRODUCT SPECIFICATION 108-127010, BASED ON EIA/ECA-364-1000.01A, (CONTROLLED ENVIRONMENT APPLICATIONS) ON MATING INTERFACE, TIN ON NEEDLE EYE.
- 5 THE ENTIRE AREA OF THE CONNECTOR FOOTPRINT, INDICATED BY THE DASHED LINE, TO BE CONSIDERED THE KEEPOUT AREA FOR COMPONENTS AND SIGNAL TRACES. TOP SIDE ONLY. TOP SIDE TRACES ALLOWED WITHIN CONNECTOR HOLE PATTERN.
- 6 LIGHT PIPE PAD LAYOUT IS FOR 0805 LOW PROFILE LED PACKAGE WITH A HEIGHT OF 0.8mm.
- 7. CAGE FINISH-1.25 μm MINIMUM NICKEL PLATING.
- 8 KEEP THE GAP BETWEEN LEDS 0.5mm MINIMUM.

BOTH LIGHT PIPES WITH DOWN DIRECTION	1-2214574-0
3 ROUND VENT HOLES	2214574-9
BOTH LIGHT PIPES	2214574-8
BOTH LIGHT PIPES	2214574-7
INNER LIGHT PIPES	2214574-6
OUTER LIGHT PIPES	2214574-5
NO LIGHT PIPES	2214574-4
BOTH LIGHT PIPES	2214574-3
INNER LIGHT PIPES	2214574-2
OUTER LIGHT PIPES	2214574-1
DESCRIPTION	PART NUMBER

THIS DRAWING IS A CONTROLLED DOCUMENT. DWN ROBERT GAN 20APR2013
 CHN JASON YANG 20APR2013
 APVD ALEX CAI 20APR2013

TE Connectivity

CAGE AND PT CONNECTOR ASSEMBLY WITH EMI GASKET, PRESS FIT, 2X2, STACKED QSFP+

SIZE CAGE CODE DRAWING NO RESTRICTED TO
 A1 00779C=2214574

CUSTOMER DRAWING SCALE 4:1 SHEET 1 OF 4 REV B

LOC	DIST	REVISIONS					
GP	00	P	LTN	DESCRIPTION	DATE	OWN	APVD
-	-	-	-	SEE SHEET 1	-	-	-

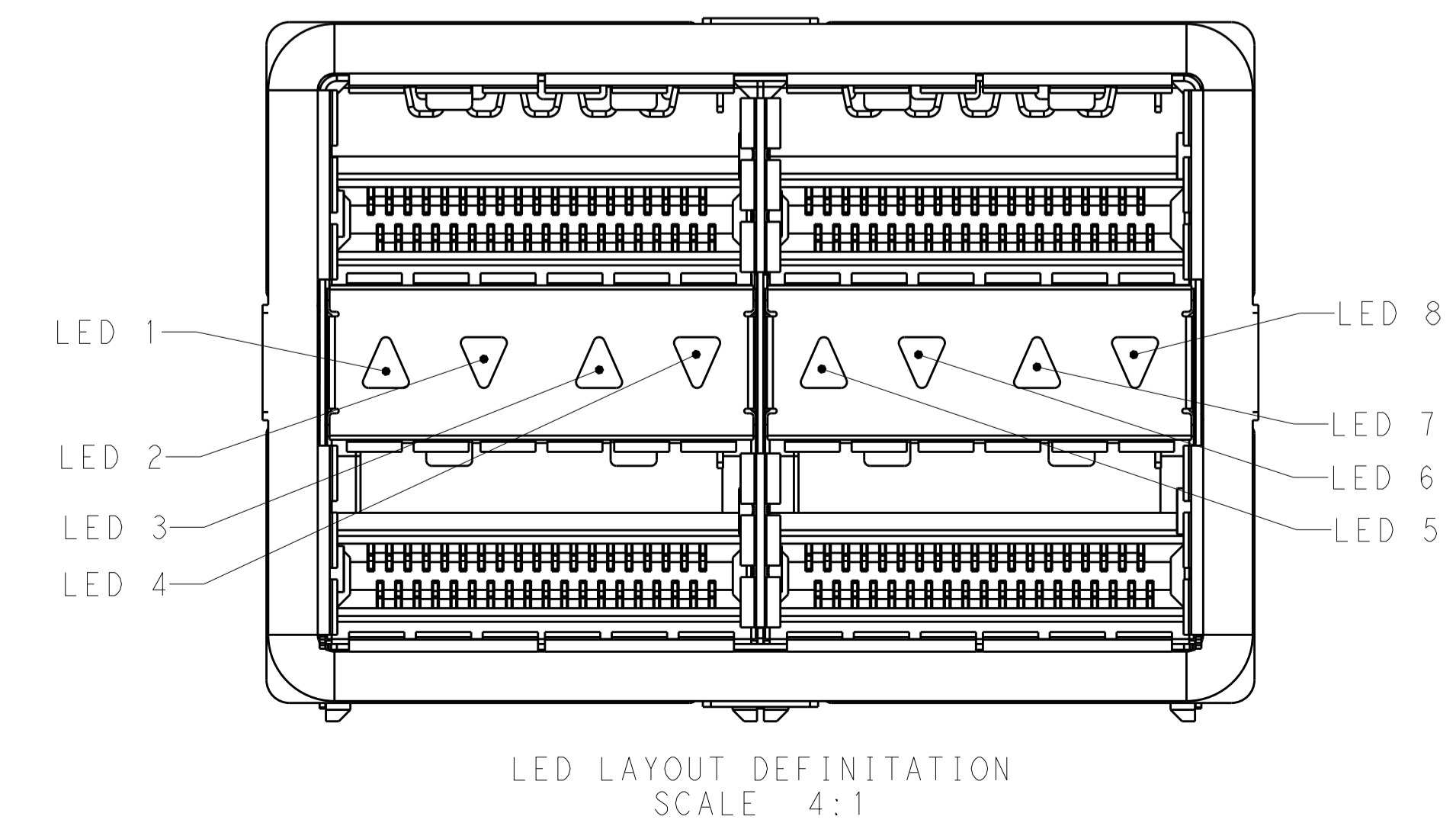
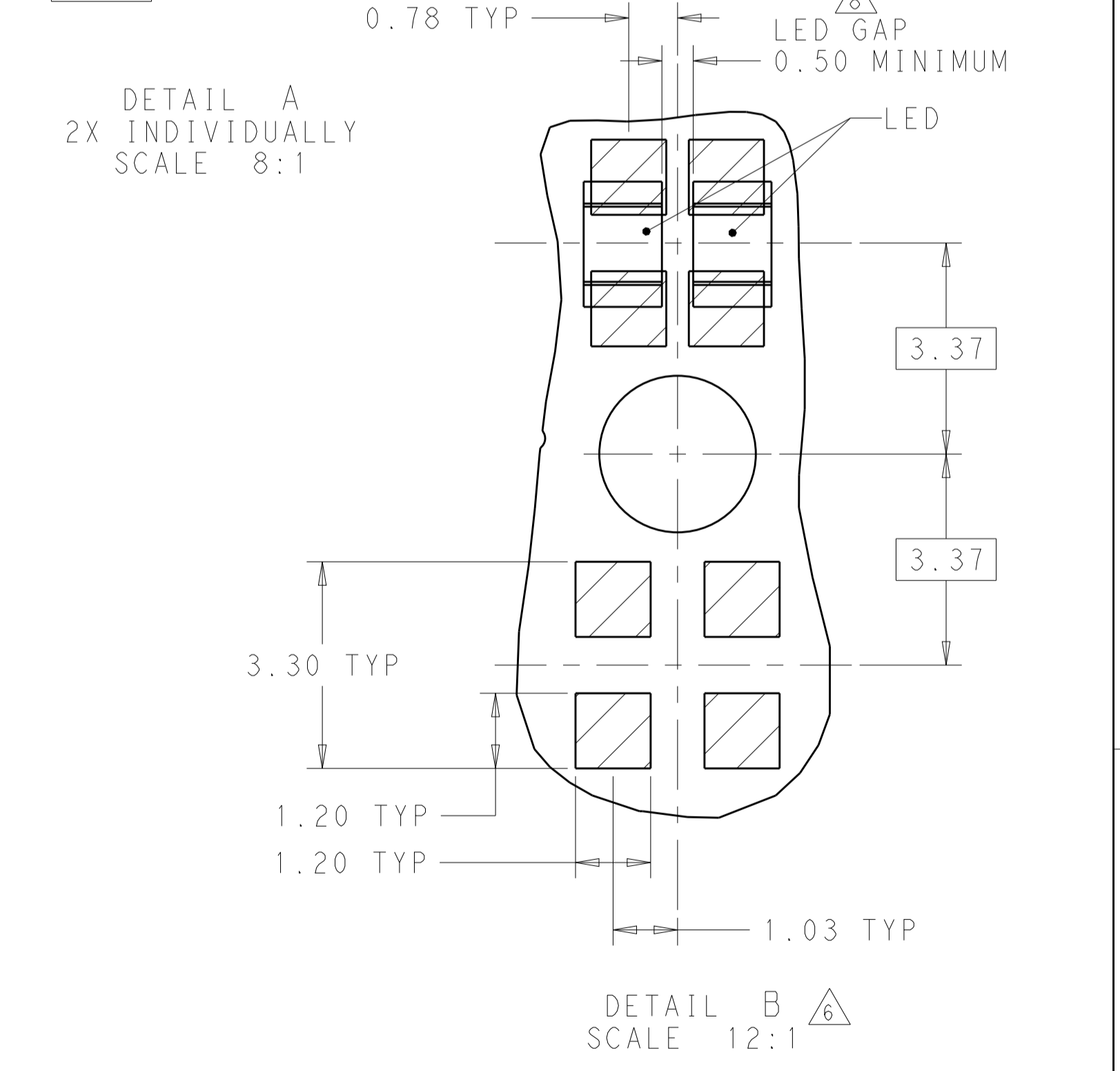
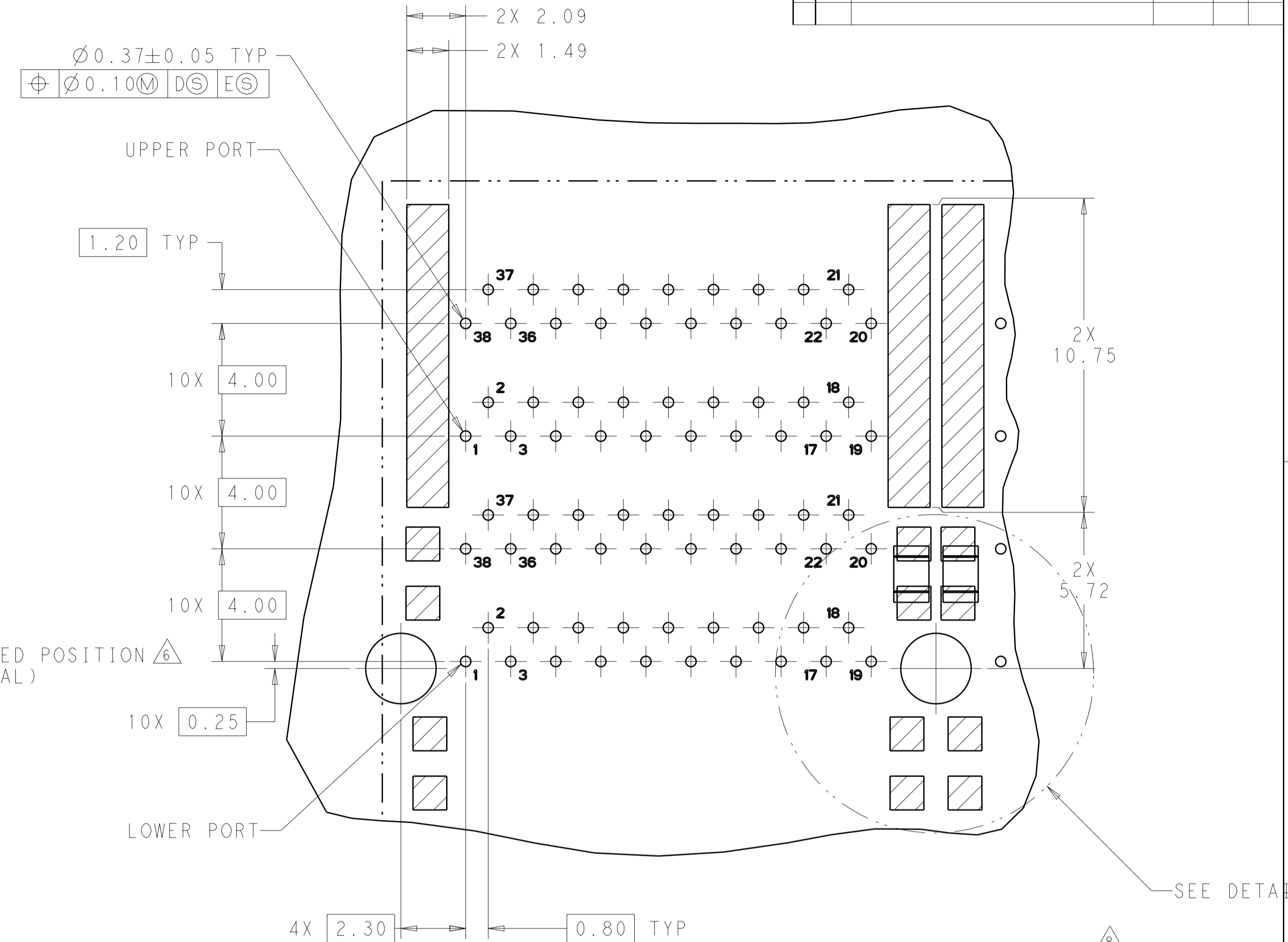
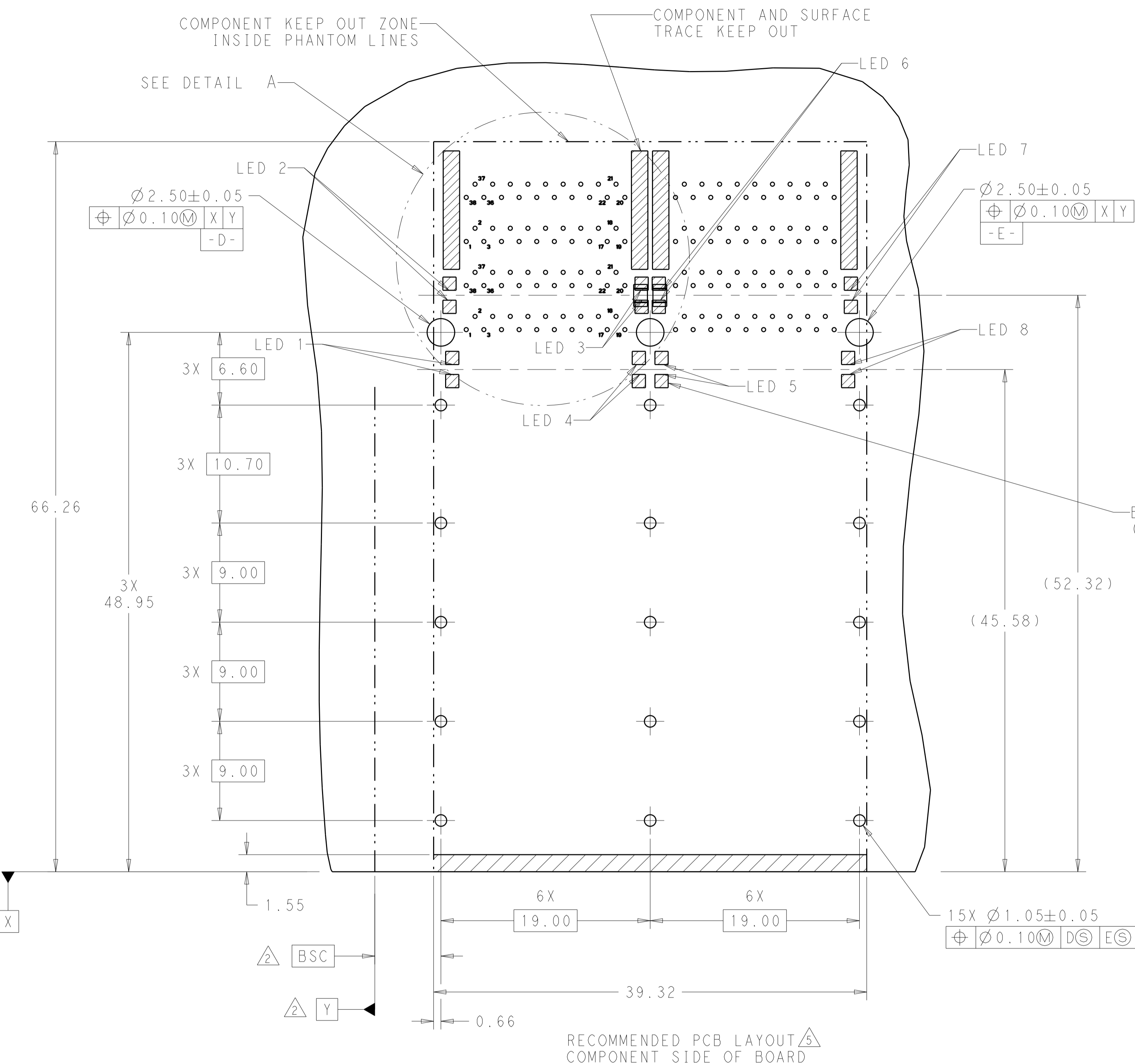

THIS DRAWING IS A CONTROLLED DOCUMENT.		OWN: ROBERT GAN 20APR2013	TE Connectivity
DIMENSIONS: mm		CHK: JASON YANG 20APR2013	
TOLERANCES UNLESS OTHERWISE SPECIFIED:		APVD: ALEX CAL 20APR2013	NAME: CAGE AND PT CONNECTOR ASSEMBLY WITH EMI GASKET, PRESS FIT, 2X2, STACKED QSFP+ PRODUCT SPEC: 108-127010 APPLICATION SPEC: 114-32020 SIZE: A1 CAGE CODE: 00779 DRAWING NO: 2214574 RESTRICTED TO: -
0 PLC ±		WEIGHT: 0.0779g	
1 PLC ±0.05		CUSTOMER DRAWING	
2 PLC ±0.05		SCALE: 4:1	
3 PLC ±		SHEET: 2 OF 4	
4 PLC ±		REV: B	
ANGLES ±			
FINISH			

LOC	DIST	REVISIONS					
		P	LTN	DESCRIPTION	DATE	DWN	APVD
GP	00	-	-	SEE SHEET 1	-	-	-

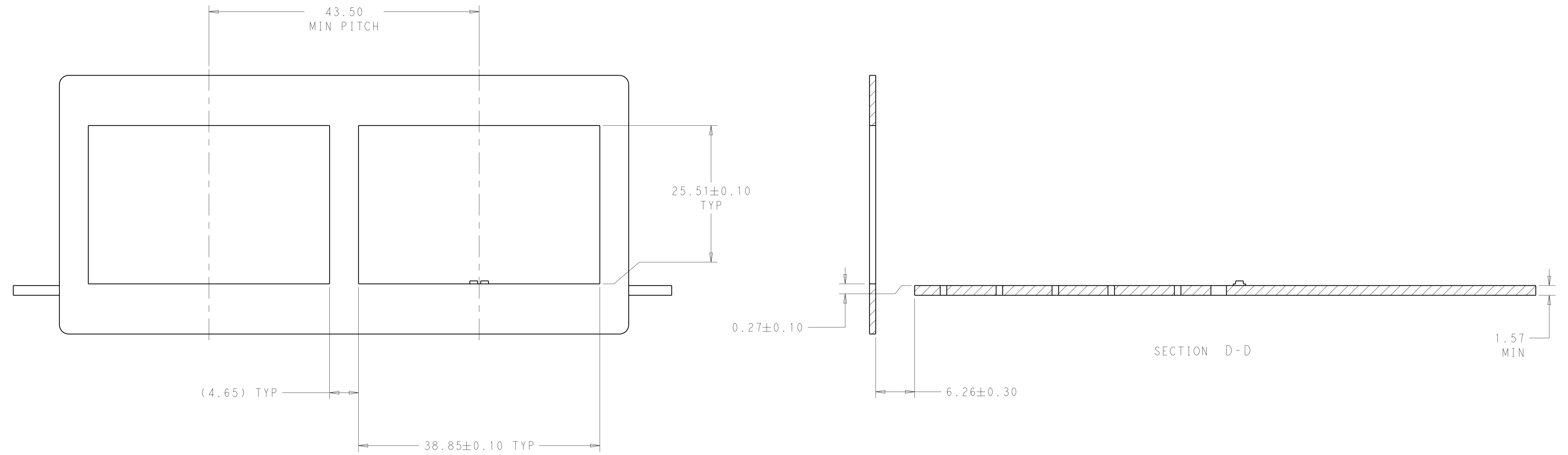

RECOMMENDED PANEL CUTOUT
 AND PC BOARD PANEL POSITION
 SCALE 3:1

THIS DRAWING IS A CONTROLLED DOCUMENT.		OWN	ROBERT GAN	20APR2013	
		CHK	JASON YANG	20APR2013	
DIMENSIONS:		APVD	ALEX CAI	20APR2013	NAME CAGE AND PT CONNECTOR ASSEMBLY WITH EMI GASKET, PRESS FIT, 2X2, STACKED QSFP+
TOLERANCES UNLESS OTHERWISE SPECIFIED:		PRODUCT SPEC	108-127010		
mm		APPLICATION SPEC	114-32020		
0 PLC ± 1 PLC ±0.25 2 PLC ±0.15 3 PLC ± 4 PLC ± ANGLES ± FINISH		RESTRICTED TO	A1 00779C=2214574		
MATERIAL		WEIGHT	CUSTOMER DRAWING		SCALE 4:1 SHEET 3 OF 4 REV B

LOC		DIST		REVISIONS			
GP	00	P	LYR	DESCRIPTION	DATE	OWN	APVD
		-		SEE SHEET 1			

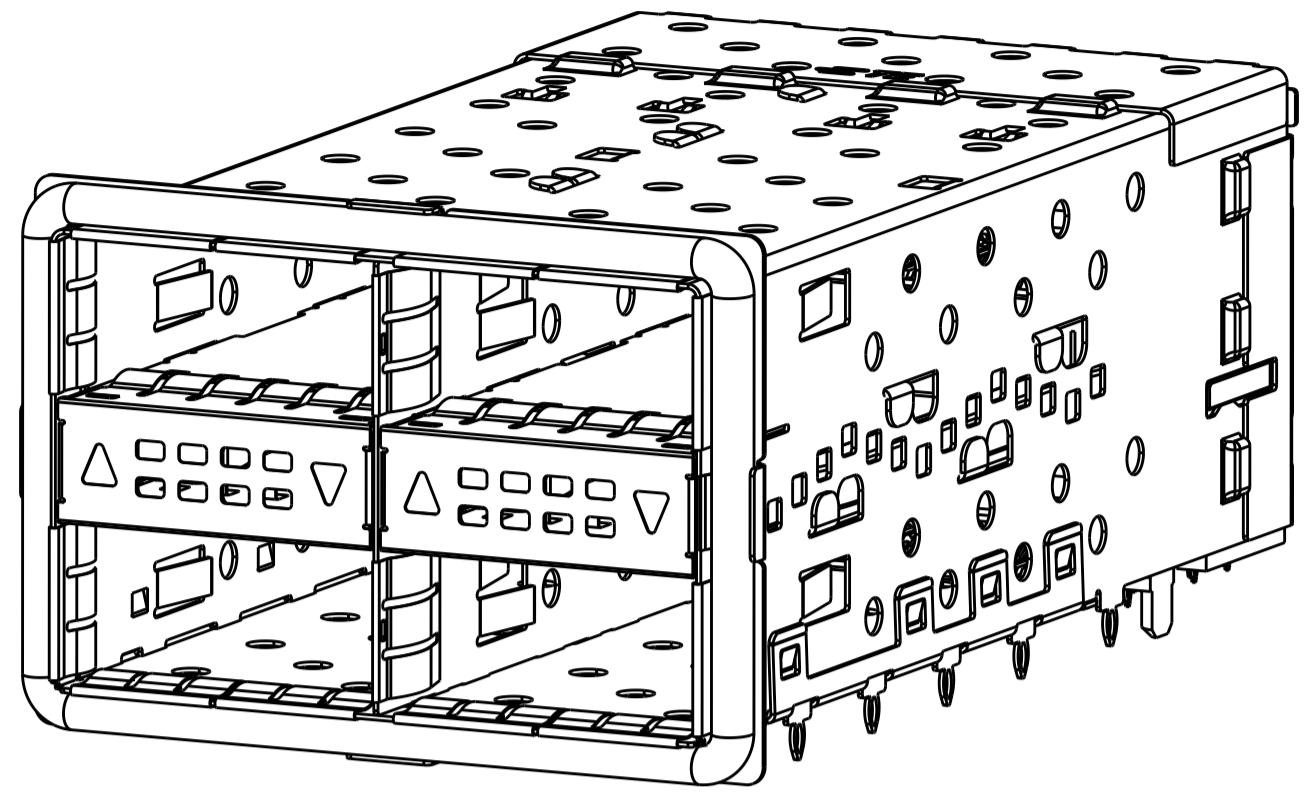

2214574-1

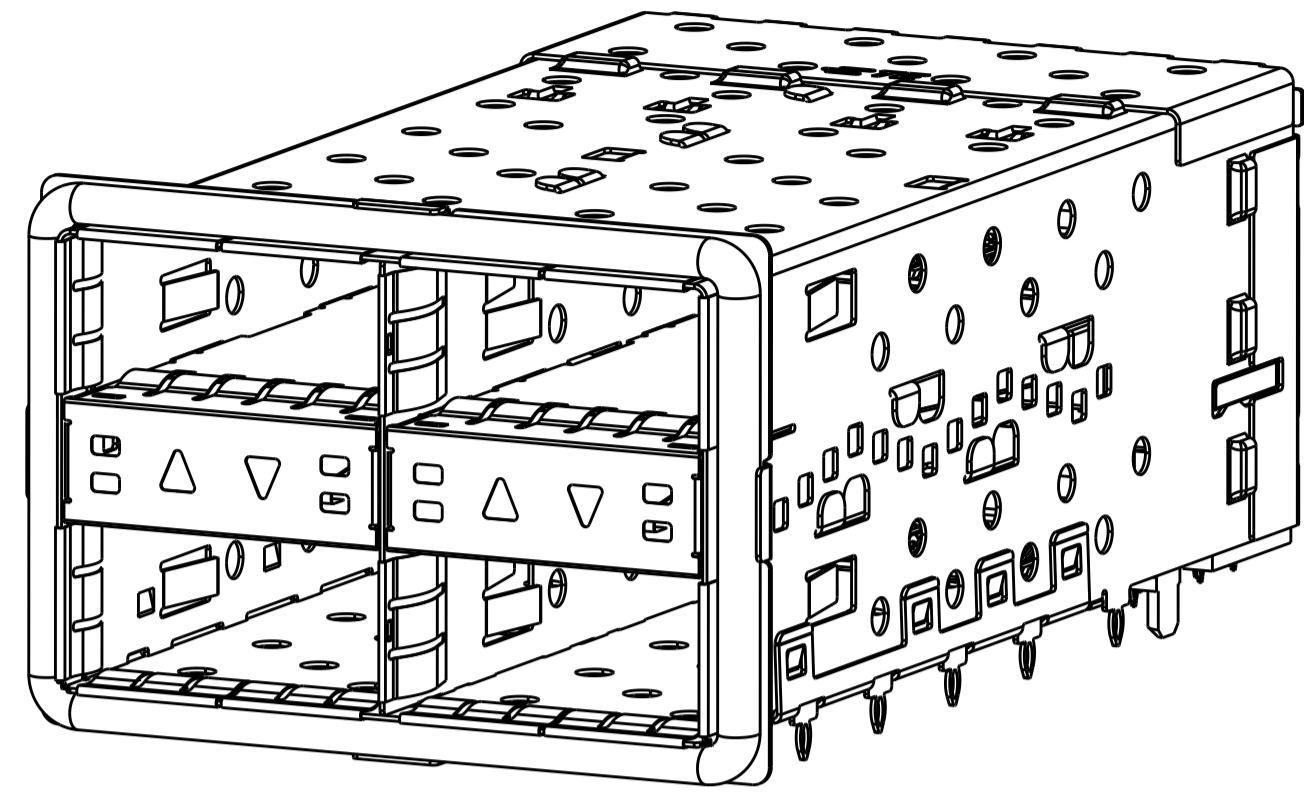

2214574-2

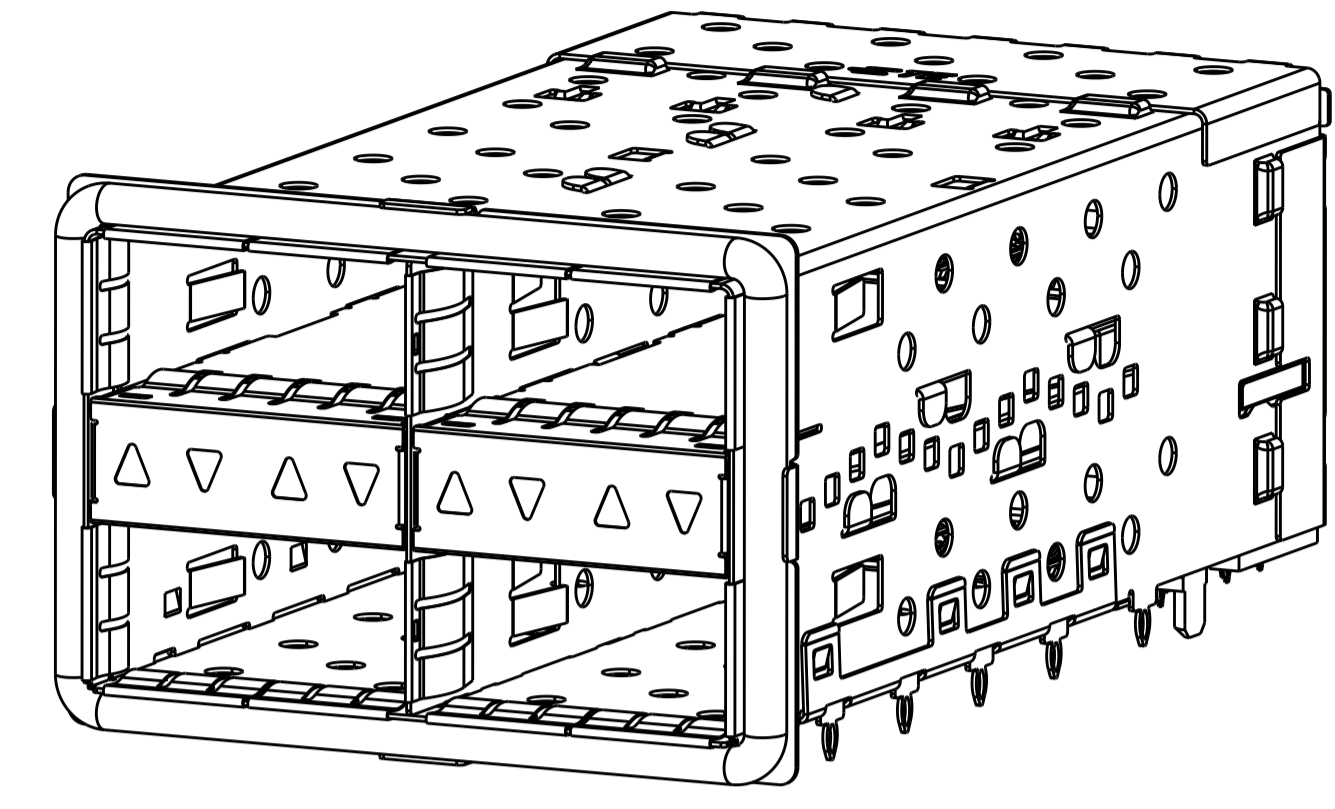

2214574-3

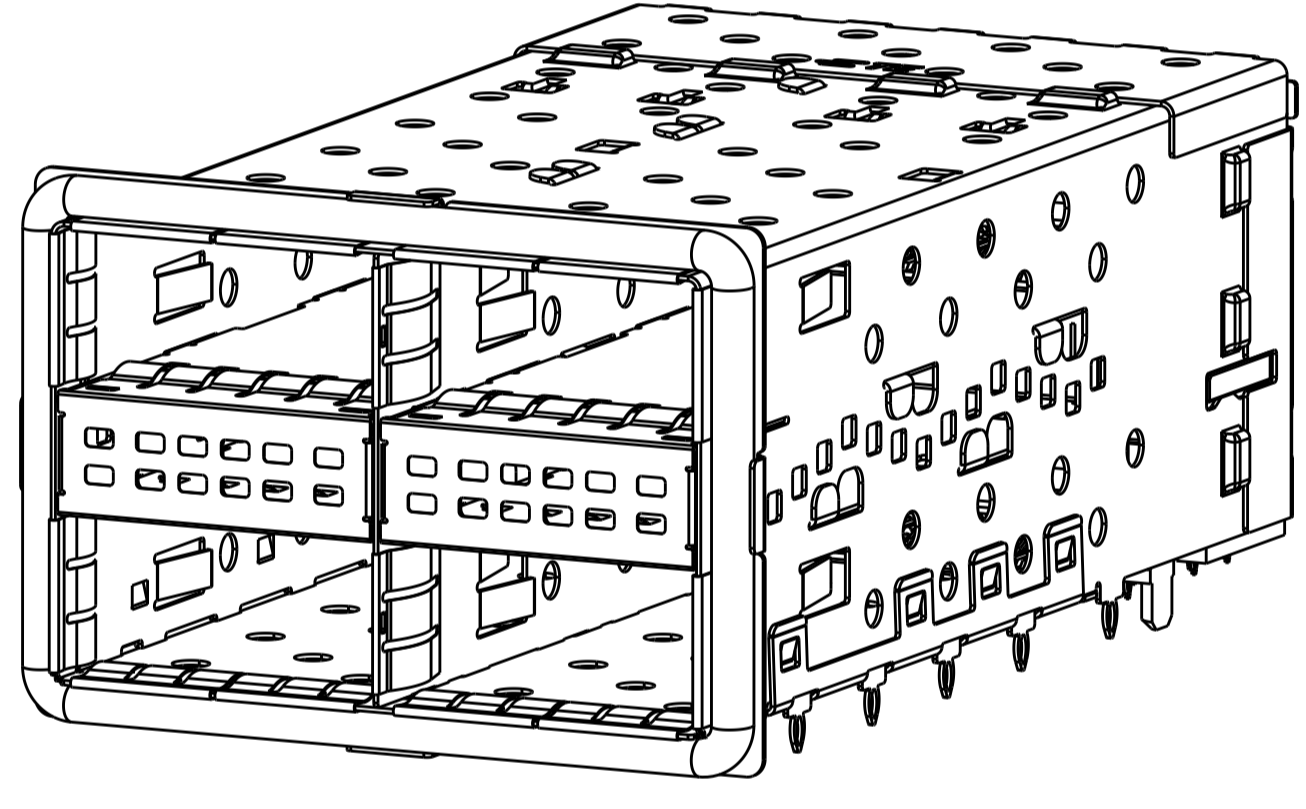

2214574-4

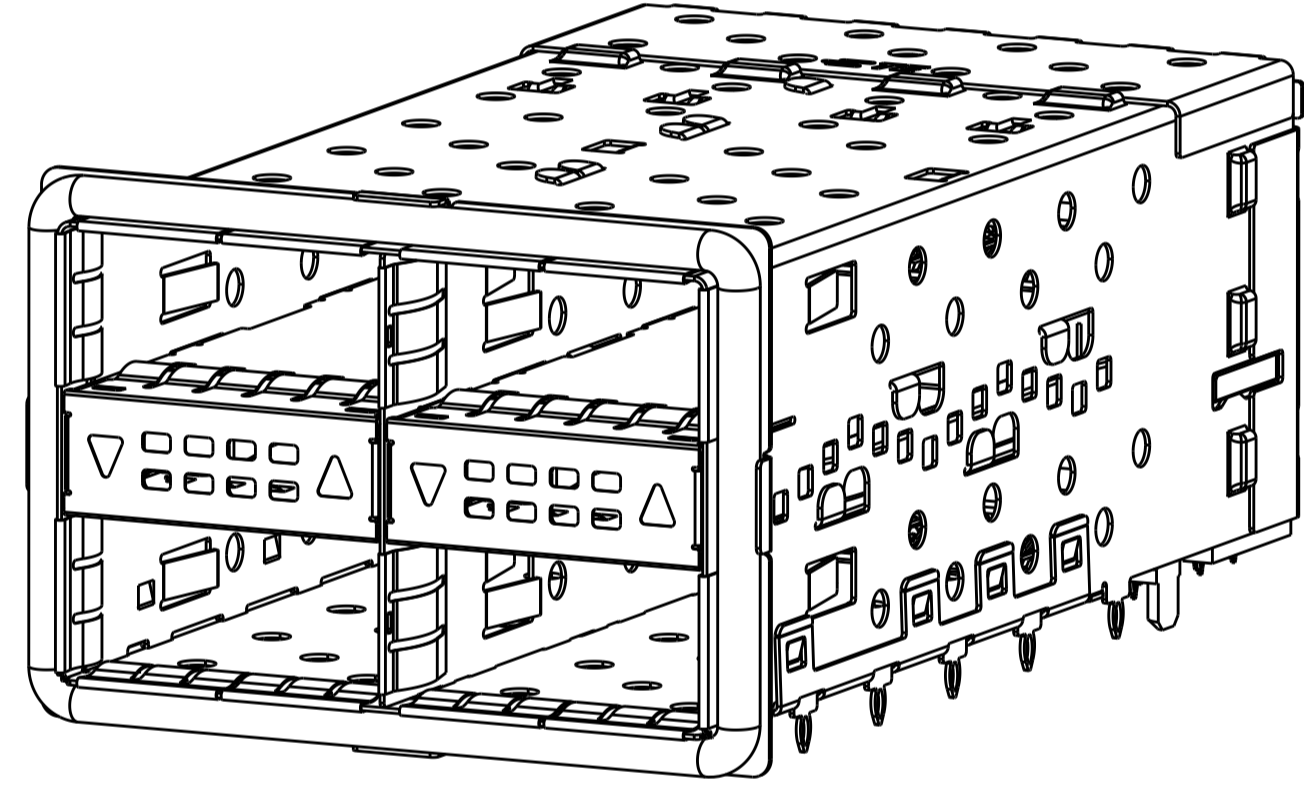

2214574-5

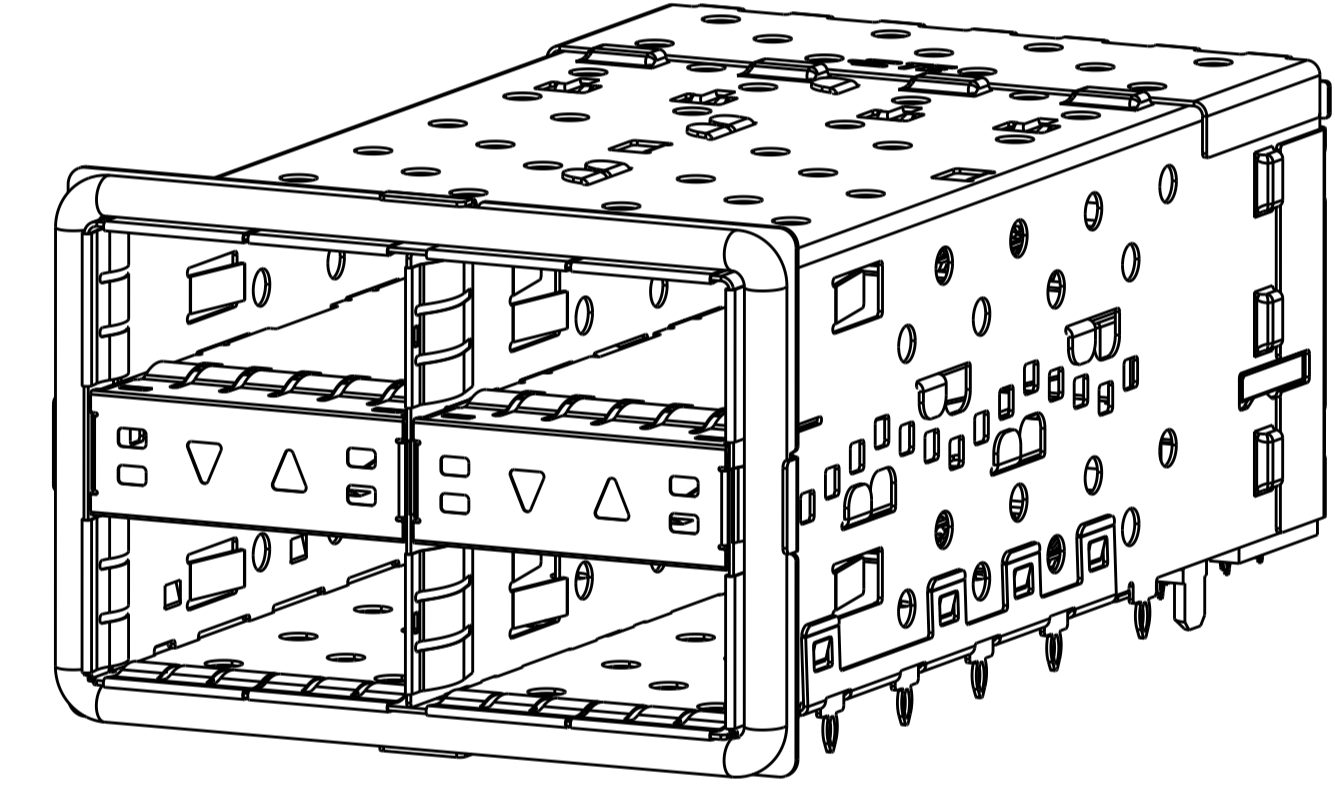

2214574-6

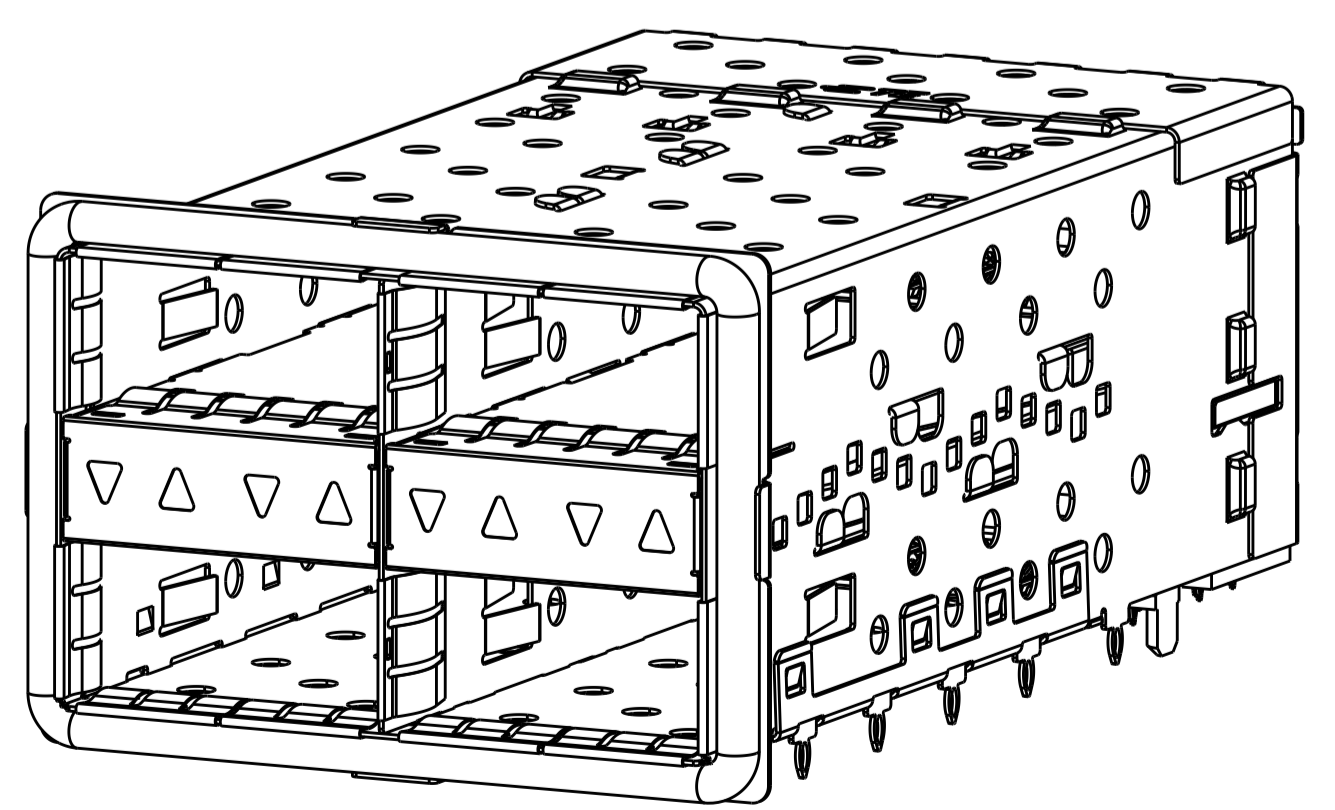

2214574-7

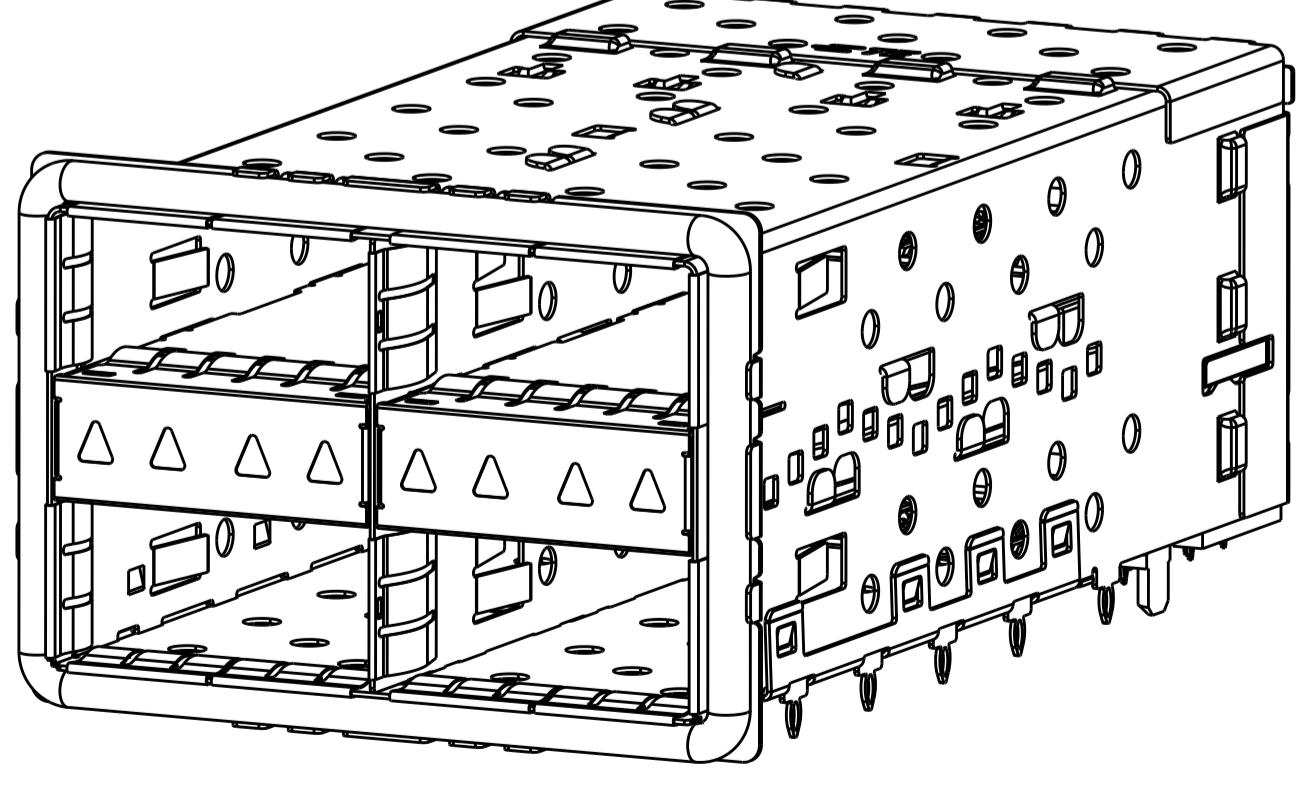

2214574-8

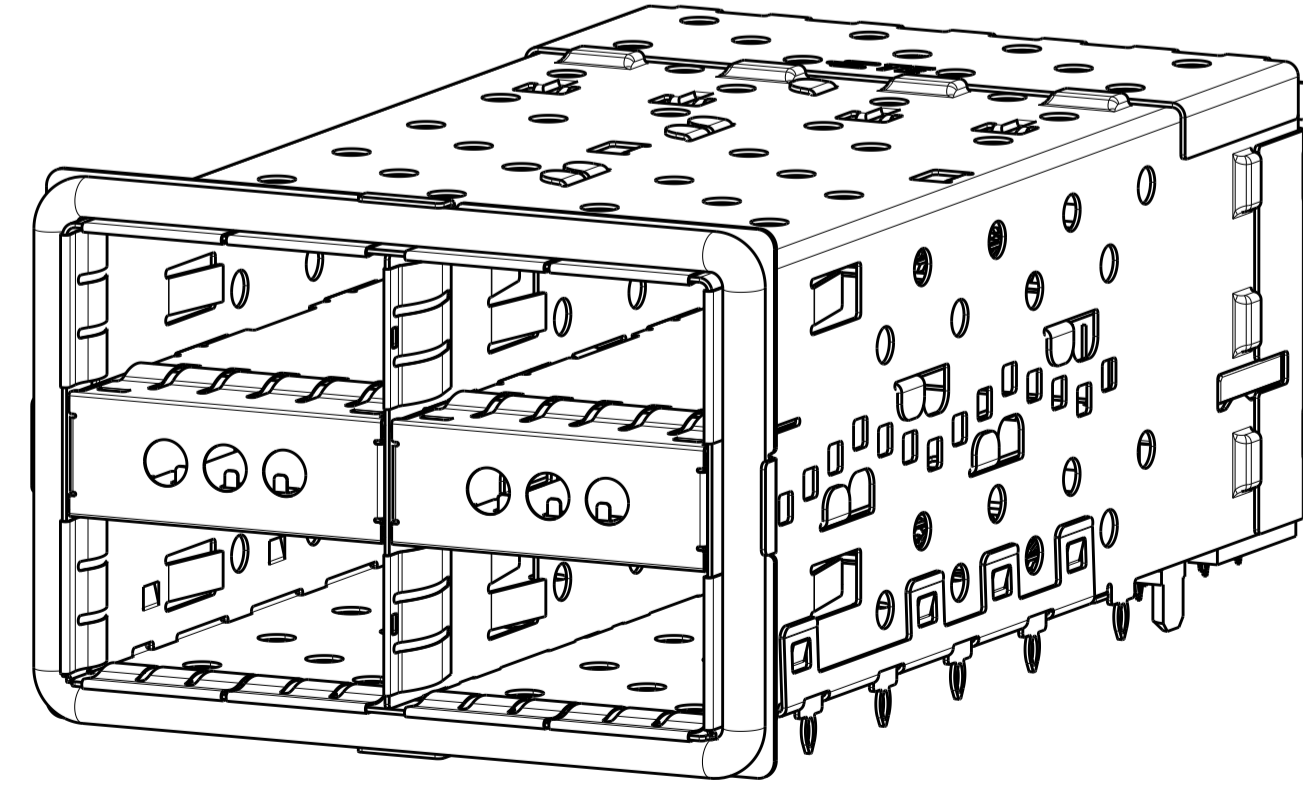

2214574-9

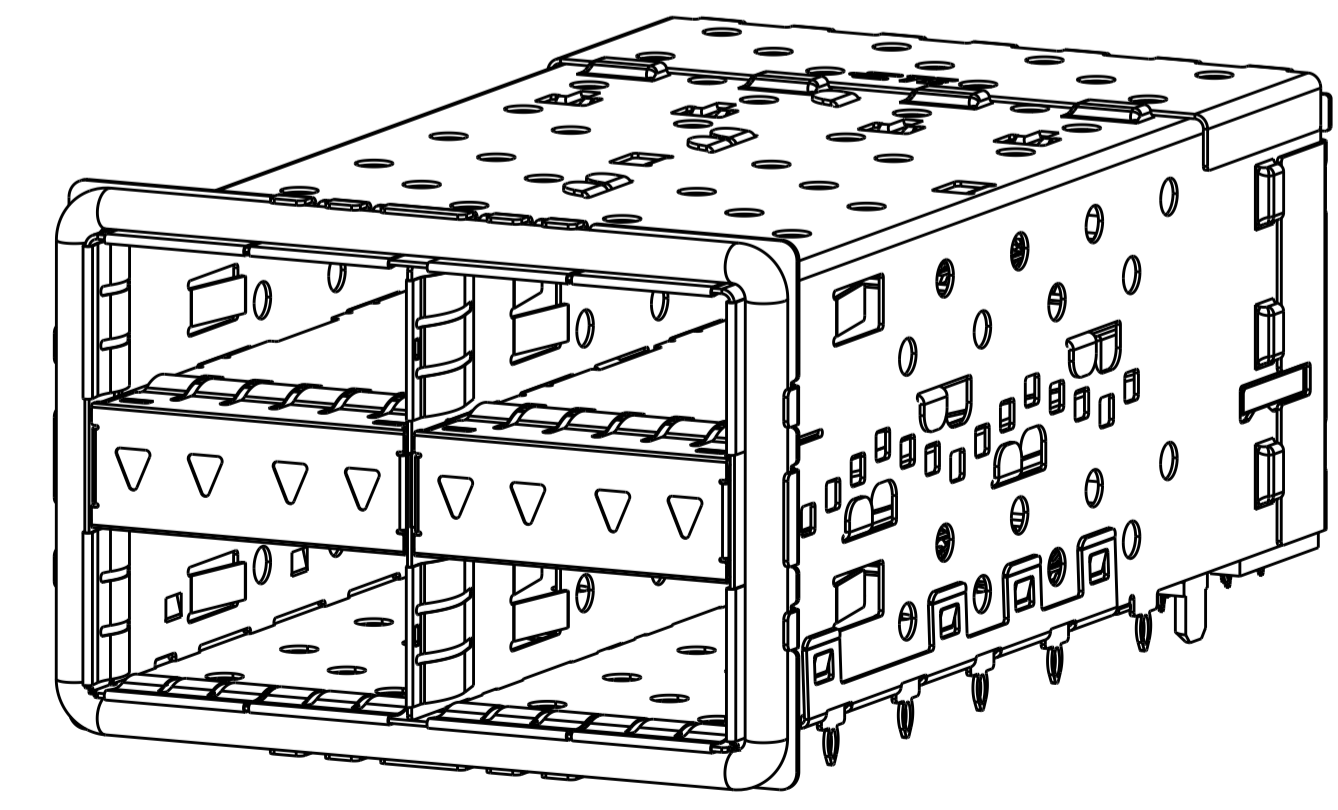

1-2214574-0

THIS DRAWING IS A CONTROLLED DOCUMENT.		OWN: ROBERT_GAN 20APR2013	TE Connectivity
		CHK: JASON YANG 20APR2013	
		APVD: ALEX CAI 20APR2013	NAME: CAGE AND PT CONNECTOR ASSEMBLY WITH EMI GASKET, PRESS FIT, 2X2, STACKED QSFP+
		PRODUCT SPEC: 108-127010	
		APPLICATION SPEC: 114-32020	SIZE: A1 CAGE CODE: 00779 DRAWING NO: 2214574
		WEIGHT: CUSTOMER DRAWING	
DIMENSIONS: mm TOLERANCES UNLESS OTHERWISE SPECIFIED: 0 PLC ± 1 PLC ±0.25 2 PLC ±0.15 3 PLC ± 4 PLC ± ANGLES ±		RESTRICTED TO:	
MATERIAL: FINISH:		SCALE: 4:1 SHEET 4 OF 4 REV B	

Компания «Life Electronics» занимается поставками электронных компонентов импортного и отечественного производства от производителей и со складов крупных дистрибьюторов Европы, Америки и Азии.

С конца 2013 года компания активно расширяет линейку поставок компонентов по направлению коаксиальный кабель, кварцевые генераторы и конденсаторы (керамические, пленочные, электролитические), за счёт заключения дистрибьюторских договоров

Мы предлагаем:

- Конкурентоспособные цены и скидки постоянным клиентам.
- Специальные условия для постоянных клиентов.
- Подбор аналогов.
- Поставку компонентов в любых объемах, удовлетворяющих вашим потребностям.
- Приемлемые сроки поставки, возможна ускоренная поставка.
- Доставку товара в любую точку России и стран СНГ.
- Комплексную поставку.
- Работу по проектам и поставку образцов.
- Формирование склада под заказчика.
- Сертификаты соответствия на поставляемую продукцию (по желанию клиента).
- Тестирование поставляемой продукции.
- Поставку компонентов, требующих военную и космическую приемку.
- Входной контроль качества.
- Наличие сертификата ISO.

В составе нашей компании организован Конструкторский отдел, призванный помогать разработчикам, и инженерам.

Конструкторский отдел помогает осуществить:

- Регистрацию проекта у производителя компонентов.
- Техническую поддержку проекта.
- Защиту от снятия компонента с производства.
- Оценку стоимости проекта по компонентам.
- Изготовление тестовой платы монтаж и пусконаладочные работы.



Тел: +7 (812) 336 43 04 (многоканальный)

Email: org@lifeelectronics.ru