

### Overview

KEMET's PEG126 is an electrolytic capacitor with an outstanding electrical performance. The device has a polarized all-welded design, tinned copper wire leads, a negative pole connected to the case, and a plastic insulation. The PEG126 winding is housed in a cylindrical aluminum can with a high purity aluminum lid and a high quality rubber gasket. The low ESR is the result of a low resistive electrolyte/paper system and an all-welded design. Thanks to its mechanical robustness, the PEG126 is suitable for use in mobile and aircraft installations, with operation up to +150°C. KEMET's automotive grade capacitors meet the demanding Automotive Electronics Council's AEC-Q200 qualification requirements.

### Applications

KEMET's PEG126 is a high performance axial electrolytic capacitor. It is designed for automotive applications, with high demands on resistance to vibrations and high ambient temperature.

### Benefits

- AEC-Q200 automotive qualified
- 2,000 hours at +150°C (D20 Case Size)
- Resistance to vibrations
- Resistance to high ambient temperature
- Low ESR
- High ripple capability
- Polarized all-welded design
- Outstanding electrical performance



### Part Number System

PEG126	H	F	368	E	Q	E1
Series	Rated Voltage (VDC)	Size Code	Capacitance Code (µF)	Version	Capacitance Tolerance	Packaging
Axial Aluminum Electrolytic	H = 25 K = 40 M = 63	See Dimension Table	The last two digits represent significant figures. The first digit indicates the total number digits.	E = Standard (with shrink tape)	Q = -10/+30% M = ±20%	E1 = Bulk

## Performance Characteristics

Item	Performance Characteristics		
Capacitance Range	250 – 4,000 $\mu$ F		
Rated Voltage	25 – 63 VDC		
Operating Temperature	-40 to +150°C		
Capacitance Tolerance	-10/+30%, ( $\pm$ 20% select values) at 100 Hz/+20°C		
Operational Lifetime	D (mm)	+125°C (hours)	+150°C (hours)
	16	6,300	1,500
	20	8,400	2,000
Shelf Life	5,000 hours at +105°C or 10 years at +40°C 0 VDC		
Leakage Current	$I = 0.003 CV + 4.0 (\mu A)$		
	C = rated capacitance ( $\mu$ F), V = rated voltage (VDC). Voltage applied for 5 minutes at +20°C.		
Vibration Test Specifications	Procedure		Requirements
	1.5 mm displacement amplitude or 20 g maximum acceleration. Vibration applied for three 2-hour sessions at 10 – 2,000 Hz (capacitor clamped by body).		No leakage of electrolyte or other visible damage. Deviations in capacitance from initial measurements must not exceed: $\Delta C/C < 5\%$
Standards	IEC 60384-4 long life grade 40/125/56, AEC-Q200		

## Compensation Factor of Ripple Current (RC) vs. Frequency

Frequency	300 Hz	1 kHz	5 kHz	100 kHz
Coefficient	0.57	0.80	1.00	1.04

## Test Method & Performance

Endurance Life Test	
Conditions	Performance
Temperature	+150°C
Test Duration	1,500 hours (D = 16 mm)
	2,000 hours (D = 20 mm)
Ripple Current	Maximum ripple current specified in table
Voltage	The sum of DC voltage and the peak AC voltage must not exceed the rated voltage of the capacitor
<b>Performance</b>	<b>The following specifications will be satisfied when the capacitor is tested at +20°C:</b>
Capacitance Change	Within 15% of the initial value
Equivalent Series Resistance	Does not exceed 200% of the initial value
Leakage Current	Does not exceed leakage current limit

# NOT FOR NEW DESIGN

## Ordering Options Table

Packaging Kind	Lead Length (mm)	Lead and Packaging Code
Standard Packaging Option		
Bulk (box)	42 +3/-2	E1

## Dimensions – Millimeters

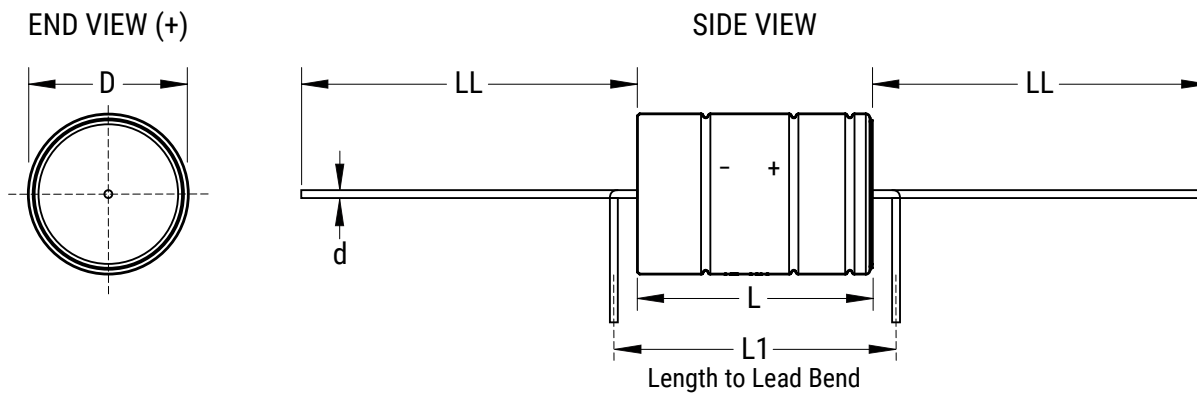

Size Code	Dimensions in mm					Approximate Weight Grams
	D	L	L1	d	LL	
	±0.5	±1	Minimum	±0.03	+3/-2	
F	16	29.0	35.0	1.0	42	8
G	16	37.0	43.0	1.0	42	11
H	20	29.0	35.0	1.0	42	13
J	20	37.0	43.0	1.0	42	20
L	20	46.0	52.0	1.0	42	24

Note: L1 is KEMET's recommendation for minimum distance between symmetrical lead bend. Available only for customer specific part numbers. Lead bend dimensions must be specified and confirmed per article.

## Shelf Life

The capacitance, ESR and impedance of a capacitor will not change significantly after extended storage periods, however, the leakage current will very slowly increase. KEMET products are particularly stable and allow a shelf life in excess of ten years at 40°C. See sectional specification under each product for specific data.

---

## Failure Rate

Estimated field failure rate:  $\leq 0.15$  ppm (failures per year/produced number of capacitors per year).

The expected failure rate for this capacitor range is based on field experience for capacitors with structural similarity.

---

## Environmental Compliance

As an environmentally conscious company, KEMET is working continuously with improvements concerning the environmental effects of both our capacitors and their production. In Europe (RoHS Directive) and in some other geographical areas like China, legislation has been put in place to prevent the use of some hazardous materials, such as lead (Pb), in electronic equipment. All products in this catalog are produced to help our customers' obligations to guarantee their products and fulfill these legislative requirements. The only material of concern in our products has been lead (Pb), which has been removed from all designs to fulfill the requirement of containing less than 0.1% of lead in any homogeneous material. KEMET will closely follow any changes in legislation world wide and make any necessary changes in its products, whenever needed.

Some customer segments such as medical, military and automotive electronics may still require the use of lead in electrode coatings. To clarify the situation and distinguish products from each other, a special symbol is used on the packaging labels for RoHS compatible capacitors.

Due to customer requirements, there may appear additional markings such as lead-free (LF) or lead-free wires (LFW) on the label.

**Table 1 – Ratings & Part Number Reference**

VDC	Rated Capacitance 100 Hz 20°C (µF)	Size Code	Case Size D x L (mm)	Ripple Current Maximum				ESR Maximum		L <sub>ESL</sub> Approximate (nH)	Part Number
				100 Hz 125°C (A)	≥ 5 kHz 105°C (A)	≥ 5 kHz 125°C (A)	≥ 5 kHz 150°C (A)	100 Hz 20°C (mΩ)	100 kHz 20°C (mΩ)		
25	680	F	16 x 29	1.4	6.9	4.1	1.6	120	43	10	PEG126HF368EQE1
25	1000	G	16 x 37	1.7	8.8	5.2	2.0	80	28	12	PEG126HG410EQE1
25	1500	G	16 x 37	2.1	9.2	5.4	2.1	63	26	12	PEG126HG415EQE1
25	2200	H	20 x 29	2.5	9.4	5.5	2.1	51	25	12	PEG126HH422EQE1
25	3300	J	20 x 37	3.2	11.7	6.9	2.6	34	17	15	PEG126HJ433EQE1
25	4000	L	20 x 46	3.7	13.1	7.7	2.9	29	14	17	PEG126HL440EME1
40	470	F	16 x 29	1.1	5.9	3.5	1.3	150	45	10	PEG126KF347EQE1
40	600	G	16 x 37	1.4	8.3	4.9	1.9	120	30	12	PEG126KG360EQE1
40	1000	H	20 x 29	1.9	9.4	5.5	2.1	75	23	12	PEG126KH410EQE1
40	1200	H	20 x 29	2.0	9.0	5.3	2.0	71	26	12	PEG126KH412EQE1
40	1500	H	20 x 29	2.2	9.7	5.7	2.2	58	22	12	PEG126KH415EQE1
40	2200	J	20 x 37	2.8	11.4	6.7	2.6	43	18	15	PEG126KJ422EQE1
40	2700	L	20 x 46	3.1	12.1	7.1	2.7	37	17	17	PEG126KL427EQE1
63	250	F	16 x 29	0.9	5.3	3.1	1.2	240	53	10	PEG126MF325EQE1
63	370	G	16 x 37	1.2	6.7	3.9	1.5	160	37	12	PEG126MG337EQE1
63	470	H	20 x 29	1.4	7.3	4.3	1.6	130	32	12	PEG126MH347EQE1
63	680	J	20 x 37	1.7	9.0	5.3	2.0	90	23	15	PEG126MJ368EQE1
63	900	L	20 x 46	2.1	10.5	6.1	2.3	69	18	17	PEG126ML390EQE1
VDC	Rated Capacitance	Size Code	Case Size	Ripple Current				ESR		L <sub>ESL</sub>	Part Number

## Operational Life

Operational life ( $L_{op}$ ) at ambient temperature  $T_a$  and ripple current  $I_{AC}$ .

Diagram valid for 20 mm case size.

Operational life,

16 mm case size: 0.75 x diagram value

Example:

Article: PEG126KJ422EQ (20 x 37 mm)

Ambient temperature ( $T_a$ ): +85°C

Ripple current, at 10 kHz ( $I_{AC}$ ): 12.0 A

$I_{RAC}(+125^\circ\text{C} \geq 5 \text{ kHz}) = 6.7 \text{ A}$  (from data table)

$\rightarrow I_{AC}/I_{RAC}(+125^\circ\text{C}) = 12.0/6.7 = 1.8$

Operational life: Interpolation between the

$L_{op}$ -curves  $\rightarrow L_{op} \sim 18\text{kh}$  (blue curves)

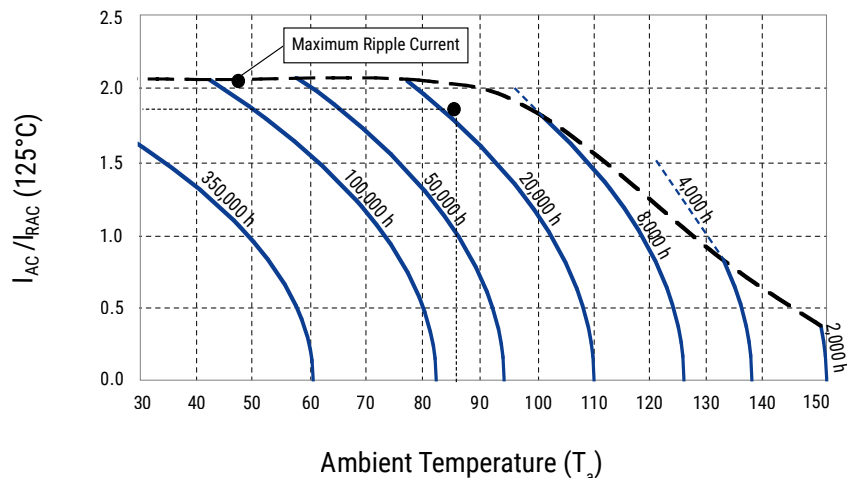

# NOT FOR NEW DESIGN

Axial Aluminum Electrolytic Capacitors – PEG126, +150°C

## Packaging Quantities

Size Code	Packaging Quantities
	Bulk
F	125
G	100
H	150
J	125
L	100

## Marking

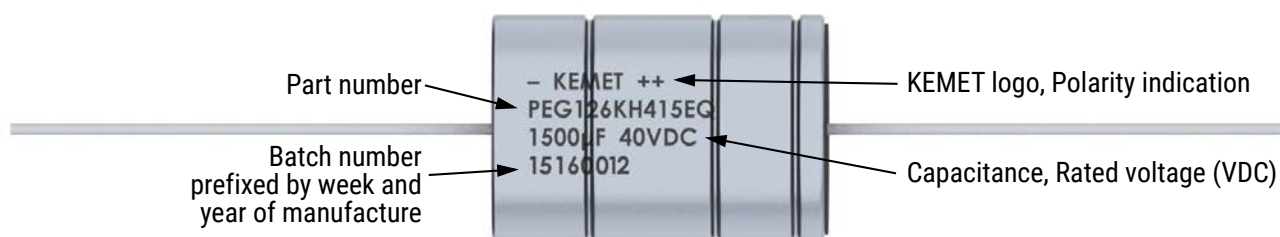

## Construction

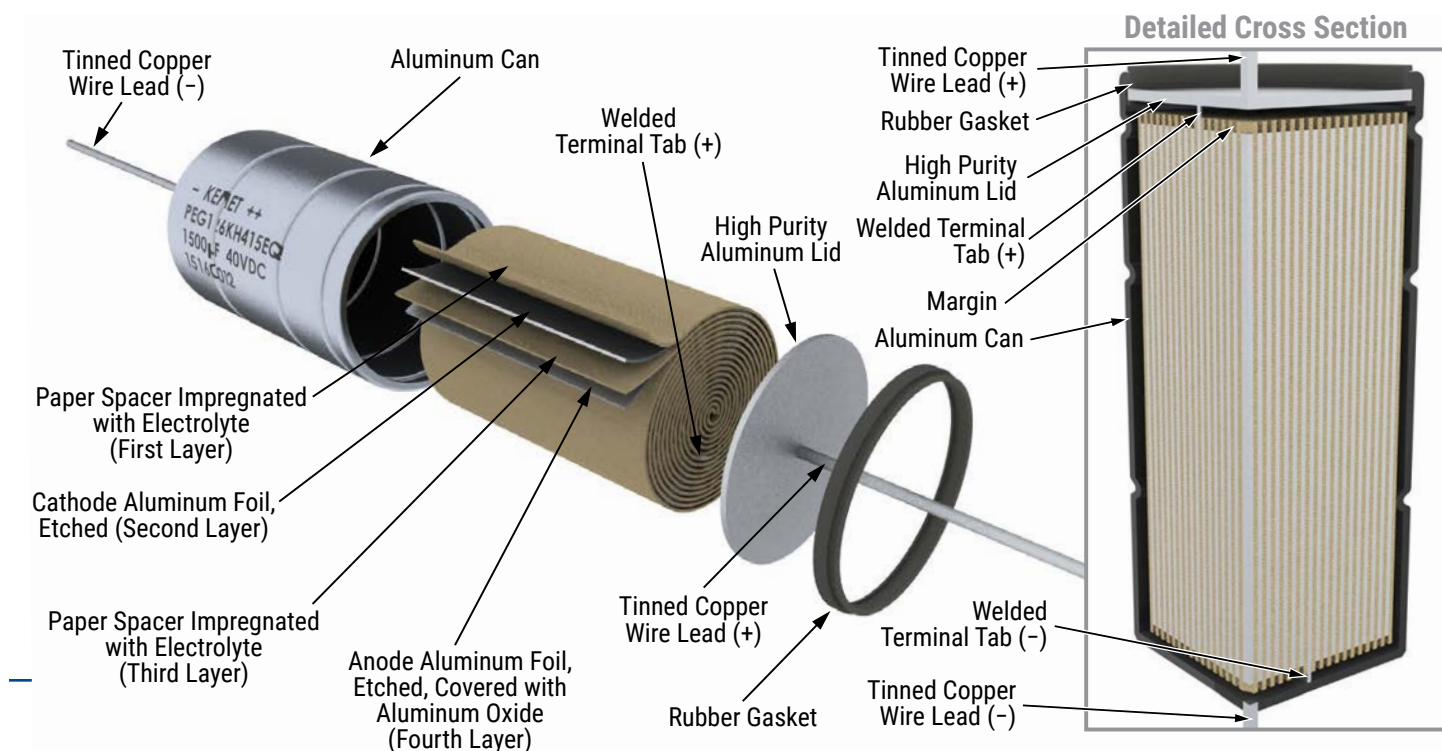

## Construction Data

The manufacturing process begins with the anode foil being electrochemically etched to increase the surface area and then “formed” to produce the aluminum oxide layer. Both the anode and cathode foils are then interleaved with absorbent paper and wound into a cylinder. During the winding process, aluminum tabs are attached to each foil to provide the electrical contact.

The winding is assembled to the capacitor Al-can and to the Al-lid. The can is filled with electrolyte and the winding is impregnated during a vacuum treatment. The capacitor is sealed. Throughout the process, all materials inside the housing must be maintained at the highest purity and be compatible with the electrolyte.

Each capacitor is aged and tested before being packed. The purpose of aging is to repair any damage in the oxide layer and thus reduce the leakage current to a very low level. Aging is carried out at elevated temperature and is accomplished by applying voltage to the device while carefully controlling the supply current. The process takes between 2 and 20 hours, depending on voltage rating.

Damage to the oxide layer can occur due to a variety of reasons:

- Slitting of the anode foil after forming
- Attaching the tabs to the anode foil
- Minor mechanical damage caused during winding

The following tests are applied for each individual capacitor.

Electrical:

- Leakage current
- Capacitance
- ESR
- Tan Delta

Mechanical/Visual:

- Pull strength test of wire terminals
- Print detail
- Box labels
- Packaging, including packed quantity

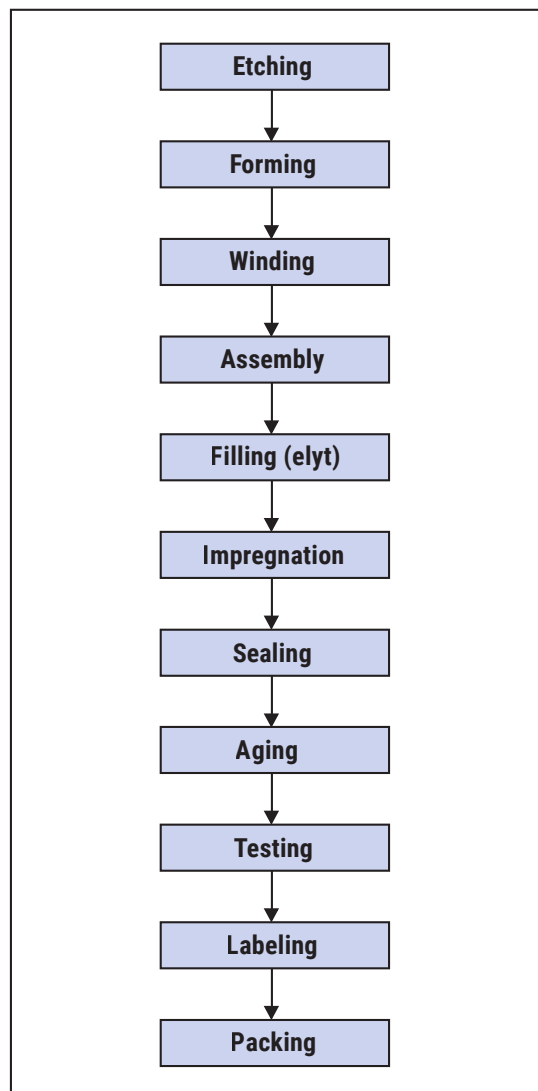
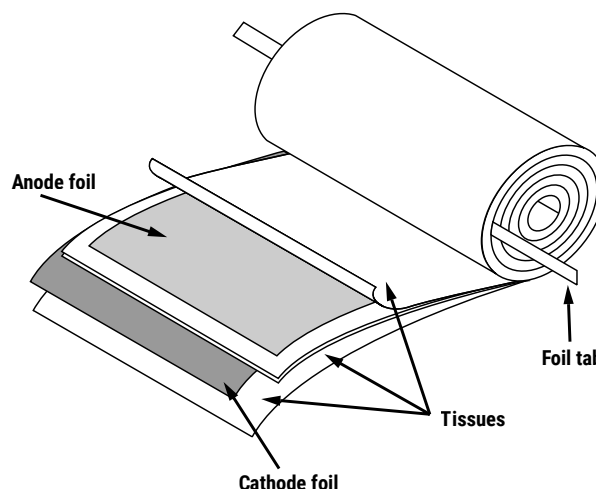

## KEMET Electronics Corporation Sales Offices

For a complete list of our global sales offices, please visit [www.kemet.com/sales](http://www.kemet.com/sales).

---

## Disclaimer

All product specifications, statements, information and data (collectively, the "Information") in this datasheet are subject to change. The customer is responsible for checking and verifying the extent to which the Information contained in this publication is applicable to an order at the time the order is placed. All Information given herein is believed to be accurate and reliable, but it is presented without guarantee, warranty, or responsibility of any kind, expressed or implied.

Statements of suitability for certain applications are based on KEMET Electronics Corporation's ("KEMET") knowledge of typical operating conditions for such applications, but are not intended to constitute – and KEMET specifically disclaims – any warranty concerning suitability for a specific customer application or use. The Information is intended for use only by customers who have the requisite experience and capability to determine the correct products for their application. Any technical advice inferred from this Information or otherwise provided by KEMET with reference to the use of KEMET's products is given gratis, and KEMET assumes no obligation or liability for the advice given or results obtained.

Although KEMET designs and manufactures its products to the most stringent quality and safety standards, given the current state of the art, isolated component failures may still occur. Accordingly, customer applications which require a high degree of reliability or safety should employ suitable designs or other safeguards (such as installation of protective circuitry or redundancies) in order to ensure that the failure of an electrical component does not result in a risk of personal injury or property damage.

Although all product-related warnings, cautions and notes must be observed, the customer should not assume that all safety measures are indicated or that other measures may not be required.

*KEMET is a registered trademark of KEMET Electronics Corporation.*



Компания «Life Electronics» занимается поставками электронных компонентов импортного и отечественного производства от производителей и со складов крупных дистрибьюторов Европы, Америки и Азии.

С конца 2013 года компания активно расширяет линейку поставок компонентов по направлению коаксиальный кабель, кварцевые генераторы и конденсаторы (керамические, пленочные, электролитические), за счёт заключения дистрибьюторских договоров

Мы предлагаем:

- Конкурентоспособные цены и скидки постоянным клиентам.
- Специальные условия для постоянных клиентов.
- Подбор аналогов.
- Поставку компонентов в любых объемах, удовлетворяющих вашим потребностям.
- Приемлемые сроки поставки, возможна ускоренная поставка.
- Доставку товара в любую точку России и стран СНГ.
- Комплексную поставку.
- Работу по проектам и поставку образцов.
- Формирование склада под заказчика.
- Сертификаты соответствия на поставляемую продукцию (по желанию клиента).
- Тестирование поставляемой продукции.
- Поставку компонентов, требующих военную и космическую приемку.
- Входной контроль качества.
- Наличие сертификата ISO.

В составе нашей компании организован Конструкторский отдел, призванный помогать разработчикам, и инженерам.

Конструкторский отдел помогает осуществить:

- Регистрацию проекта у производителя компонентов.
- Техническую поддержку проекта.
- Защиту от снятия компонента с производства.
- Оценку стоимости проекта по компонентам.
- Изготовление тестовой платы монтаж и пусконаладочные работы.



Тел: +7 (812) 336 43 04 (многоканальный)

Email: [org@lifeelectronics.ru](mailto:org@lifeelectronics.ru)