

REV	DOCUMENT	CHANGED BY	CHECK
1	201373	TRF 22SEP00	SAV
2	203123	GJW 01JUN01	SAV

SERIES
UNAMPLIFIED COMPENSATED AND CALIBRATED (mV)

ACCURACY GRADE
C - COMMERCIAL (1.0%)
H - HIGH GRADE (0.50%)

PRESSURE RANGE Δ
004, 010 IN H₂O D
00.3, 01, 05, 15, 30, 60, 100, 150, 240 PSID

PACKAGE TYPE
N - PLASTIC

PRESSURE REFERENCE
D - DIFFERENTIAL

NOTES

Δ ALL PARAMETERS ARE MEASURED AT 12 VDC EXCITATION. APPLY POSITIVE PRESSURE TO PORT 2 FOR POSITIVE GOING OUTPUT SHIFT IS RELATIVE TO 25°C

Δ LINEARITY IS DETERMINED USING BEST STRAIGHT LINE FIT THROUGH ZERO, 1/2 FULL SCALE, AND FULL SCALE; HYSTERESIS IS MECHANICAL ONLY

4 - SPAN IS THE ALGEBRAIC DIFFERENCE BETWEEN OFFSET VOLTAGE AND THE VOLTAGE AT FULL SCALE PRESSURE

Δ PRESSURE RANGE DEPICTS THE FULL SCALE PRESSURE OF THE SENSOR

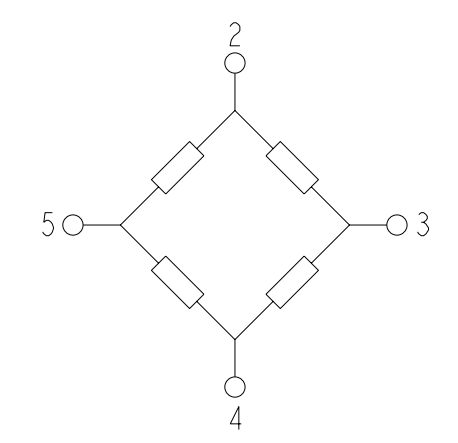

EQUIVALENT CIRCUIT

PIN OUT	
1	N/C
2	+V EXCITATION
3	+ OUTPUT SIGNAL
4	-V EXCITATION
5	- OUTPUT SIGNAL
6	N/C

C - GRADE LISTINGS	
XCXL004DNC	
XCXL010DNC	
XCX00.3DNC	
XCX01DNC	
XCX05DNC	
XCX15DNC	
XCX30DNC	
XCX60DNC	
XCX100DNC	
XCX150DNC	
XCX240DNC	
H - GRADE LISTINGS	
XCXL004DNH	
XCXL010DNH	
XCX00.3DNH	
XCX01DNH	
XCX05DNH	
XCX15DNH	
XCX30DNH	
XCX60DNH	
XCX100DNH	
XCX150DNH	
XCX240DNH	

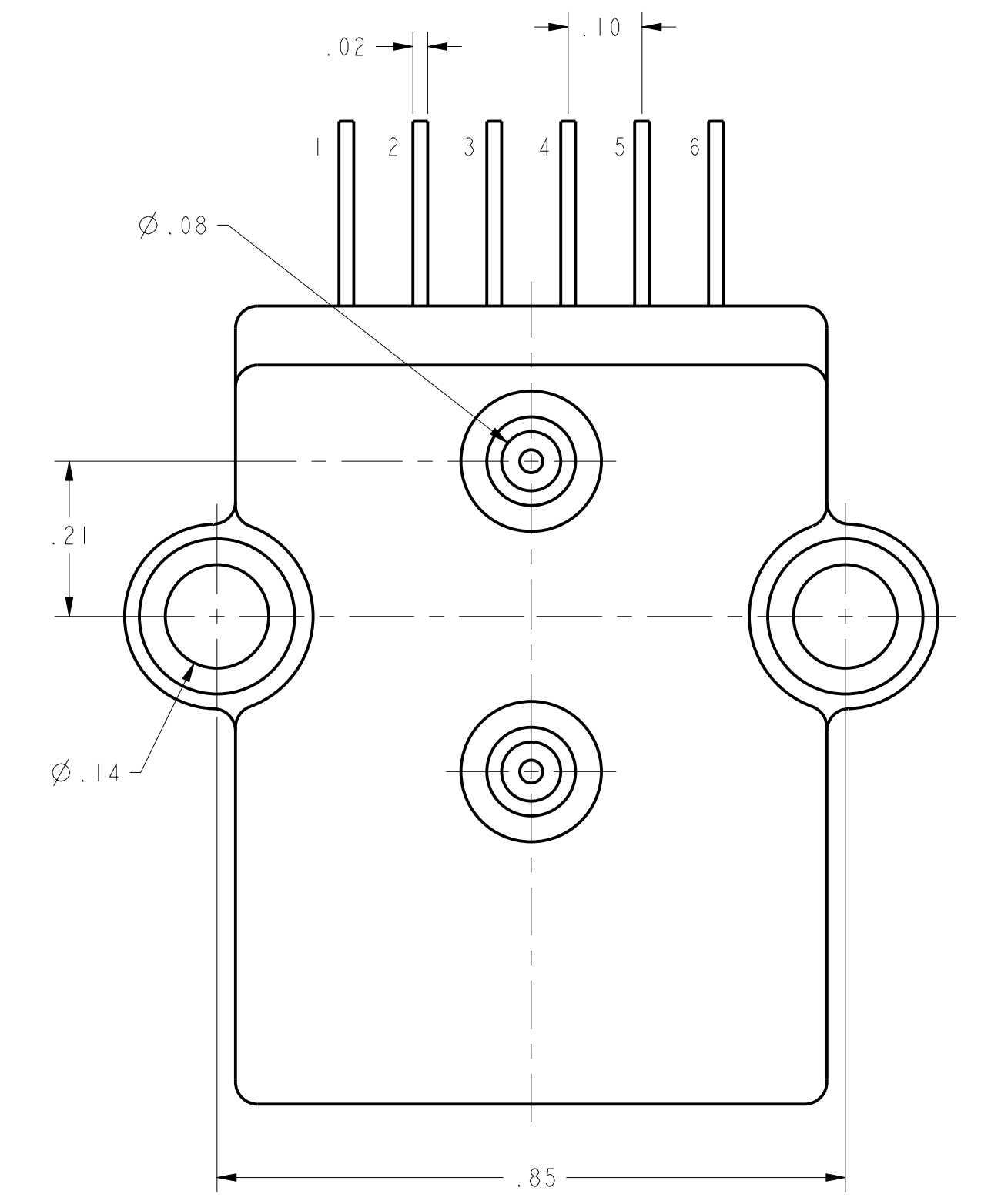
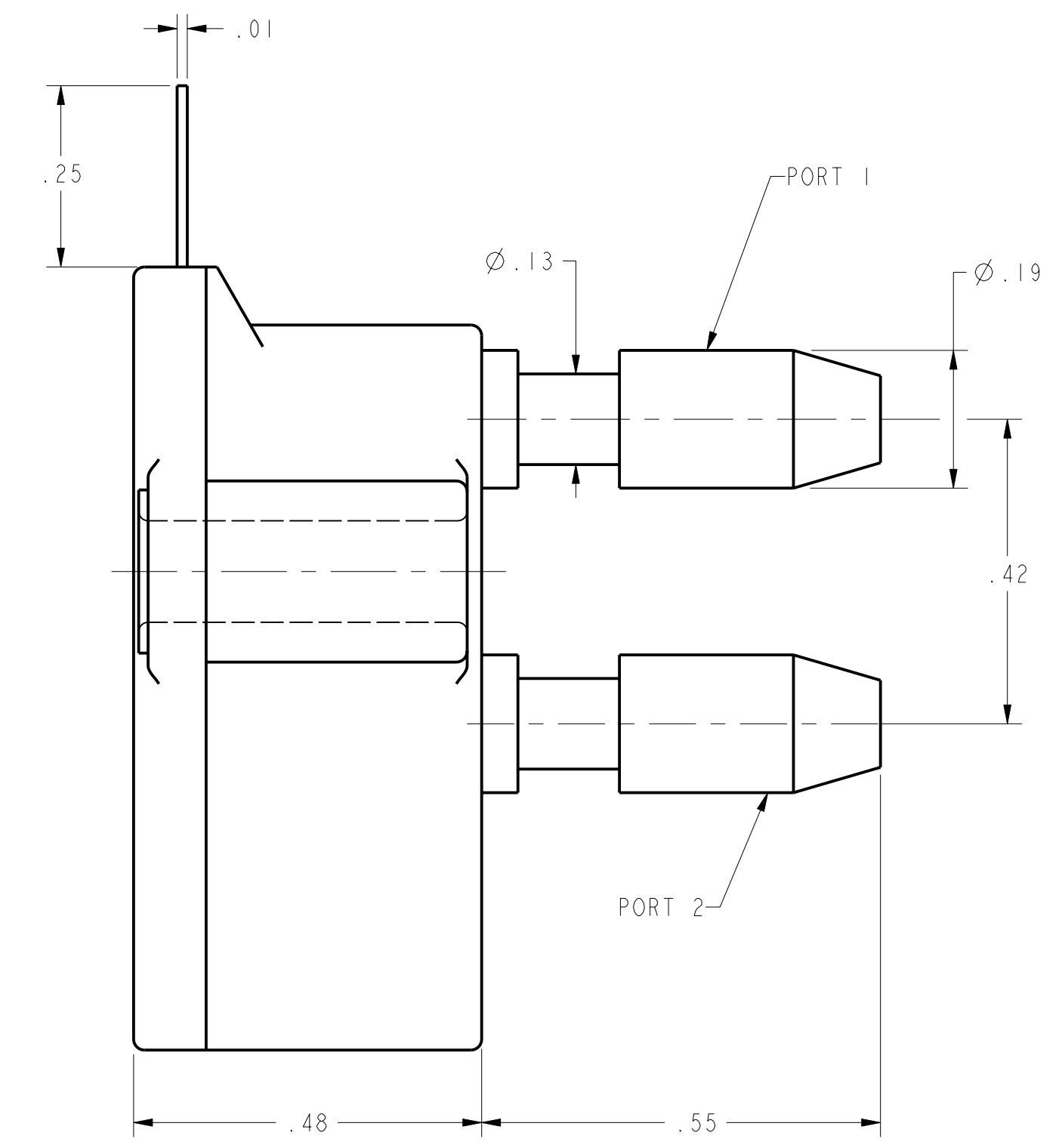
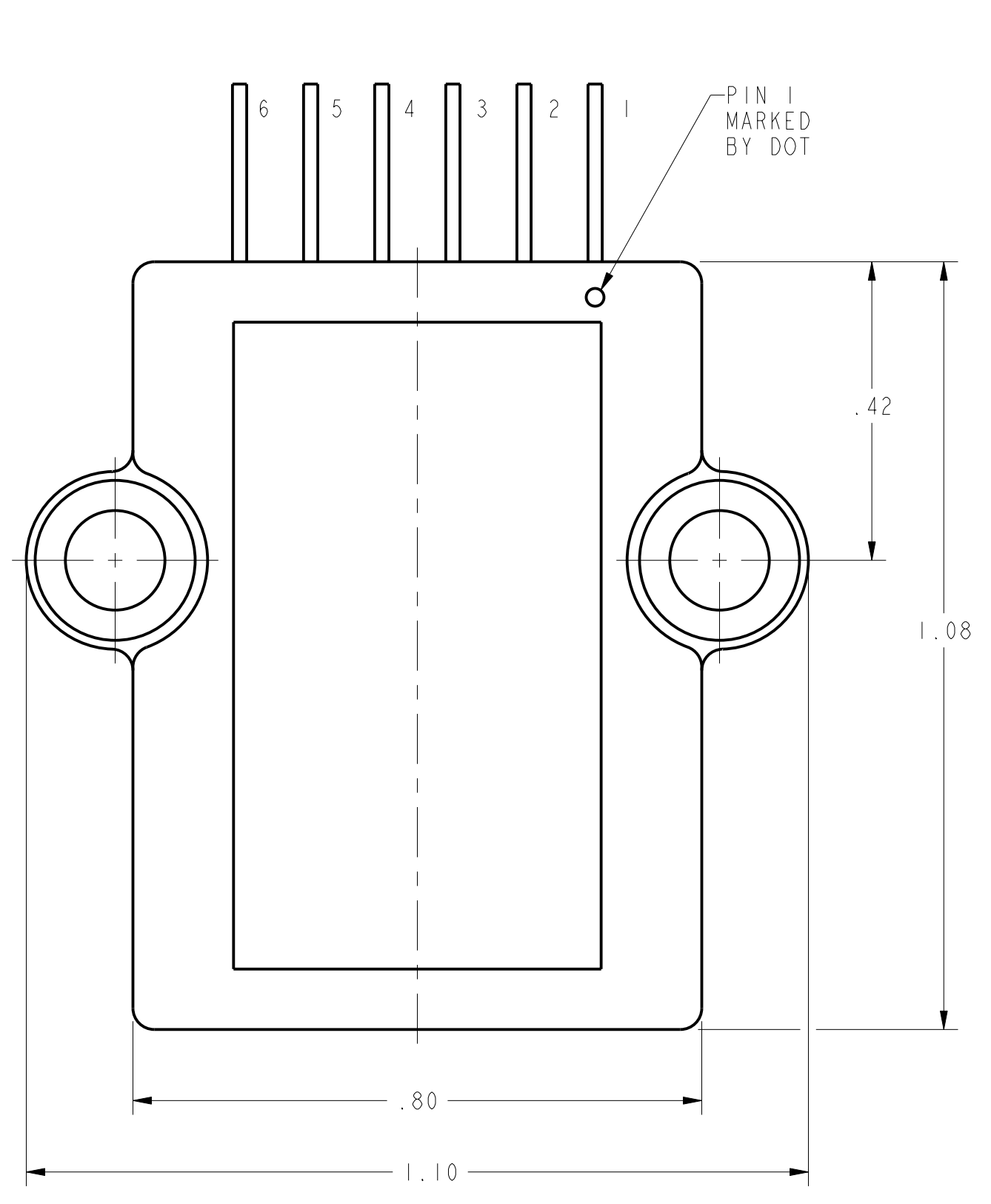

PARAMETERS Δ	PRESSURE RANGE	C GRADE				H GRADE				PROOF PRESSURE
		MIN	NOM	MAX	UNITS	MIN	NOM	MAX	UNITS	
OFFSET VOLTAGE (0 IN H ₂ O DIFF)	ALL	-1.0	0.0	1.0	mV	-0.3	0.0	0.3	mV	5 PSID 5 PSID 5 PSID 5 PSID 15 PSID 45 PSID 90 PSID 180 PSID 200 PSID 300 PSID 300 PSID
SPAN (P2>P1)	4 IN H ₂ O	38.0	40.0	42.0	mV	19.8	20.0	20.2	mV	
	10 IN H ₂ O	19.0	20.0	21.0	mV	19.8	20.0	20.2	mV	
	0.3 PSID	19.0	20.0	21.0	mV	19.8	20.0	20.2	mV	
	1 PSID	17.0	18.0	19.0	mV	17.8	18.0	18.2	mV	
	5 PSID	57.0	60.0	63.0	mV	59.0	60.0	61.0	mV	
	15 PSID	85.0	90.0	95.0	mV	89.0	90.0	91.0	mV	
	30 PSID	85.0	90.0	95.0	mV	89.0	90.0	91.0	mV	
	60 PSID	85.0	90.0	95.0	mV	89.0	90.0	91.0	mV	
	100 PSID	95.0	100.0	105.0	mV	99.0	100.0	101.0	mV	
	150 PSID	85.0	90.0	95.0	mV	89.0	90.0	91.0	mV	
240 PSID	95.0	100.0	105.0	mV	99.0	100.0	101.0	mV		
COMBINED LINEARITY AND HYSTERESIS Δ	ALL	---	0.5	1.0	%SPAN	---	0.3	0.5	%SPAN	
INPUT RESISTANCE	ALL	---	15	---	K Ω	---	15	---	K Ω	
TEMPERATURE ERROR ON OFFSET (0° TO 50°C) Δ	4 IN H ₂ O	---	---	1.0	mV	---	---	0.5	mV	
TEMPERATURE ERROR ON OFFSET (0° TO 70°C) Δ	ALL EXCEPT 4 IN H ₂ O	---	---	1.0	mV	---	---	0.5	mV	
TEMPERATURE ERROR ON SPAN (0° TO 50°C) Δ	4 IN H ₂ O	---	---	2.0	%SPAN	---	---	1.0	%SPAN	
TEMPERATURE ERROR ON SPAN (0° TO 70°C) Δ	ALL EXCEPT 4 IN H ₂ O	---	---	2.0	%SPAN	---	---	1.0	%SPAN	
REPEATABILITY	ALL	---	0.1	---	%SPAN	---	0.1	---	%SPAN	

EXCITATION VOLTAGE	ALL	3	12	16	VDC
COMPENSATED TEMPERATURE RANGE	ALL	0	25	70	°C
STORAGE TEMPERATURE RANGE	ALL	-40	---	125	°C
RELATIVE HUMIDITY (NON-CONDENSING)	ALL	0	---	95	%RH
SHOCK (DURATION 11 msec ANY AXIS)	ALL	---	---	10	g
COMMON MODE PRESSURE	ALL	---	---	50	PSIG

MEDIA CAPABILITY, WETTED MATERIALS
(APPLY CLEAN DRY AIR ONLY)

PRESSURE PORT 2: SILICON DIAPHRAGM, GLASS FILLED NYLON, AND ALUMINA CERAMIC. PORT NOT USED FOR ABSOLUTE DEVICES

PRESSURE PORT 1: FRONTSIDE OF SILICON DIAPHRAGM, SILICONE GEL PASSIVATION, GLASS FILLED NYLON, ALUMINA.

UNLESS OTHERWISE SPECIFIED TOLERANCES ARE:	NO PLACE .X	ONE PLACE .XX	TWO PLACE .XXX	THREE PLACE .XXX	ANGLES	RAW MATERIAL - COMMERCIAL STANDARD	THIRD ANGLE PROJECTION	DRAWN TRF 22SEP00	CHECK SAV 22SEP00	Honeywell Sensing and Control PRESSURE SENSOR	
<small>THIS DRAWING COVERS A PROPRIETARY ITEM AND IS THE PROPERTY OF HONEYWELL SENSING AND CONTROL. THIS DRAWING IS NOT TO BE COPIED OR USED WITHOUT THE PERMISSION OF HONEYWELL.</small>								DIMENSIONS ARE TO BE MET BEFORE PROTECTIVE COATINGS ARE APPLIED.		TITLE PRESSURE SENSOR	
SCALE: 5:1								DWG TYPE: M	DRAWING NAME: XCX DIF SERIES CHART 1	REV: 2	SHEET: 1 OF 1

Компания «Life Electronics» занимается поставками электронных компонентов импортного и отечественного производства от производителей и со складов крупных дистрибьюторов Европы, Америки и Азии.

С конца 2013 года компания активно расширяет линейку поставок компонентов по направлению коаксиальный кабель, кварцевые генераторы и конденсаторы (керамические, пленочные, электролитические), за счёт заключения дистрибьюторских договоров

Мы предлагаем:

- Конкурентоспособные цены и скидки постоянным клиентам.
- Специальные условия для постоянных клиентов.
- Подбор аналогов.
- Поставку компонентов в любых объемах, удовлетворяющих вашим потребностям.
- Приемлемые сроки поставки, возможна ускоренная поставка.
- Доставку товара в любую точку России и стран СНГ.
- Комплексную поставку.
- Работу по проектам и поставку образцов.
- Формирование склада под заказчика.
- Сертификаты соответствия на поставляемую продукцию (по желанию клиента).
- Тестирование поставляемой продукции.
- Поставку компонентов, требующих военную и космическую приемку.
- Входной контроль качества.
- Наличие сертификата ISO.

В составе нашей компании организован Конструкторский отдел, призванный помогать разработчикам, и инженерам.

Конструкторский отдел помогает осуществить:

- Регистрацию проекта у производителя компонентов.
- Техническую поддержку проекта.
- Защиту от снятия компонента с производства.
- Оценку стоимости проекта по компонентам.
- Изготовление тестовой платы монтаж и пусконаладочные работы.



Тел: +7 (812) 336 43 04 (многоканальный)
Email: org@lifeelectronics.ru