



# MC9328MXL



**Package Information**  
Plastic Package  
Case 1304B-01  
(MAPBGA-225)

### Ordering Information

See [Table 1 on page 3](#)

# MC9328MXL

## 1 Introduction

The i.MX Family of applications processors provides a leap in performance with an ARM9™ microprocessor core and highly integrated system functions. The i.MX family specifically addresses the requirements of the personal, portable product market by providing intelligent integrated peripherals, an advanced processor core, and power management capabilities.

The MC9328MXL (i.MXL) processor features the advanced and power-efficient ARM920T™ core that operates at speeds up to 200 MHz. Integrated modules, which include a USB device, an LCD controller, and an MMC/SD host controller, support a suite of peripherals to enhance portable products seeking to provide a rich multimedia experience. It is packaged in either a 256-contact Mold Array Process-Ball Grid Array (MAPBGA) or 225-contact MAPBGA package.

[Figure 1](#) shows the functional block diagram of the i.MXL processor.

## Contents

1 Introduction .....	1
2 Signals and Connections .....	4
3 Electrical Characteristics .....	17
4 Functional Description and Application Information .....	20
5 Pin-Out and Package Information .....	84
6 Product Documentation .....	88
Contact Information .....	Last Page



Freescale reserves the right to change the detail specifications as may be required to permit improvements in the design of its products.

© Freescale Semiconductor, Inc., 2004, 2005, 2006. All rights reserved.





Figure 1. i.MXL Functional Block Diagram

## 1.1 Features

To support a wide variety of applications, the processor offers a robust array of features, including the following:

- ARM920T™ Microprocessor Core
- AHB to IP Bus Interfaces (APIs)
- External Interface Module (EIM)
- SDRAM Controller (SDRAMC)
- DPLL Clock and Power Control Module
- Two Universal Asynchronous Receiver/Transmitters (UART 1 and UART 2)
- Serial Peripheral Interface (SPI)
- Two General-Purpose 32-bit Counters/Timers
- Watchdog Timer
- Real-Time Clock/Sampling Timer (RTC)
- LCD Controller (LCDC)
- Pulse-Width Modulation (PWM) Module
- Universal Serial Bus (USB) Device
- Multimedia Card and Secure Digital (MMC/SD) Host Controller Module
- Memory Stick® Host Controller (MSHC)
- Direct Memory Access Controller (DMAC)
- Synchronous Serial Interface and an Inter-IC Sound (SSI/I<sup>2</sup>S) Module
- Inter-IC (I<sup>2</sup>C) Bus Module

- Video Port
- General-Purpose I/O (GPIO) Ports
- Bootstrap Mode
- Multimedia Accelerator (MMA)
- Power Management Features
- Operating Voltage Range: 1.7 V to 1.9 V core, 1.7 V to 3.3 V I/O
- 256-pin MAPBGA Package
- 225-contact MAPBGA Package

## 1.2 Target Applications

The i.MXL processor is targeted for advanced information appliances, smart phones, Web browsers, digital MP3 audio players, handheld computers, and messaging applications.

## 1.3 Ordering Information

Table 1 provides ordering information.

**Table 1. i.MXL Ordering Information**

Package Type	Frequency	Temperature	Solderball Type	Order Number
256-lead MAPBGA	200 MHz	0°C to 70°C	Pb-free	MC9328MXLVM20(R2)
		-30°C to 70°C	Pb-free	MC9328MXLDVM20(R2)
	150 MHz	0°C to 70°C	Pb-free	MC9328MXLVM15(R2)
		-30°C to 70°C	Pb-free	MC9328MXLDVM15(R2)
		-40°C to 85°C	Pb-free	MC9328MXLCVM15(R2)
225-lead MAPBGA	200 MHz	0°C to 70°C	Pb-free	MC9328MXLVP20(R2)
		-30°C to 70°C	Pb-free	MC9328MXLDVP20(R2)
	150 MHz	0°C to 70°C	Pb-free	MC9328MXLVP15(R2)
		-30°C to 70°C	Pb-free	MC9328MXLDVP15(R2)
		-40°C to 85°C	Pb-free	MC9328MXLCVP15(R2)

## 1.4 Conventions

This document uses the following conventions:

- $\overline{\text{OVERBAR}}$  is used to indicate a signal that is active when pulled low: for example,  $\overline{\text{RESET}}$ .
- *Logic level one* is a voltage that corresponds to Boolean true (1) state.
- *Logic level zero* is a voltage that corresponds to Boolean false (0) state.
- To *set* a bit or bits means to establish logic level one.
- To *clear* a bit or bits means to establish logic level zero.
- A *signal* is an electronic construct whose state conveys or changes in state convey information.

- A *pin* is an external physical connection. The same pin can be used to connect a number of signals.
- *Asserted* means that a discrete signal is in active logic state.
  - *Active low* signals change from logic level one to logic level zero.
  - *Active high* signals change from logic level zero to logic level one.
- *Negated* means that an asserted discrete signal changes logic state.
  - *Active low* signals change from logic level zero to logic level one.
  - *Active high* signals change from logic level one to logic level zero.
- LSB means *least significant bit* or *bits*, and MSB means *most significant bit* or *bits*. References to low and high bytes or words are spelled out.
- Numbers preceded by a percent sign (%) are binary. Numbers preceded by a dollar sign (\$) or 0x are hexadecimal.

## 2 Signals and Connections

Table 2 identifies and describes the i.MXL processor signals that are assigned to package pins. The signals are grouped by the internal module that they are connected to.

**Table 2. i.MXL Signal Descriptions**

Signal Name	Function/Notes
<b>External Bus/Chip-Select (EIM)</b>	
A[24:0]	Address bus signals
D[31:0]	Data bus signals
$\overline{EB0}$	MSB Byte Strobe—Active low external enable byte signal that controls D [31:24].
$\overline{EB1}$	Byte Strobe—Active low external enable byte signal that controls D [23:16].
$\overline{EB2}$	Byte Strobe—Active low external enable byte signal that controls D [15:8].
$\overline{EB3}$	LSB Byte Strobe—Active low external enable byte signal that controls D [7:0].
$\overline{OE}$	Memory Output Enable—Active low output enables external data bus.
$\overline{CS}$ [5:0]	Chip-Select—The chip-select signals $\overline{CS}$ [3:2] are multiplexed with $\overline{CSD}$ [1:0] and are selected by the Function Multiplexing Control Register (FMCR). By default $\overline{CSD}$ [1:0] is selected.
$\overline{ECB}$	Active low input signal sent by a flash device to the EIM whenever the flash device must terminate an on-going burst sequence and initiate a new (long first access) burst sequence.
$\overline{LBA}$	Active low signal sent by a flash device causing the external burst device to latch the starting burst address.
BCLK (burst clock)	Clock signal sent to external synchronous memories (such as burst flash) during burst mode.
$\overline{RW}$	$\overline{RW}$ signal—Indicates whether external access is a read (high) or write (low) cycle. Used as a $\overline{WE}$ input signal by external DRAM.
$\overline{DTACK}$	$\overline{DTACK}$ signal—The external input data acknowledge signal. When using the external $\overline{DTACK}$ signal as a data acknowledge signal, the bus time-out monitor generates a bus error when a bus cycle is not terminated by the external $\overline{DTACK}$ signal after 1022 clock counts have elapsed.

Table 2. i.MXL Signal Descriptions (Continued)

Signal Name	Function/Notes
<b>Bootstrap</b>	
BOOT [3:0]	System Boot Mode Select—The operational system boot mode of the i.MXL processor upon system reset is determined by the settings of these pins.
<b>SDRAM Controller</b>	
SDBA [4:0]	SDRAM non-interleave mode bank address multiplexed with address signals A [15:11]. These signals are logically equivalent to core address p_addr [25:21] in SDRAM cycles.
SDIBA [3:0]	SDRAM interleave addressing mode bank address multiplexed with address signals A [19:16]. These signals are logically equivalent to core address p_addr [12:9] in SDRAM cycles.
MA [11:10]	SDRAM address signals
MA [9:0]	SDRAM address signals which are multiplexed with address signals A [10:1]. MA [9:0] are selected on SDRAM cycles.
DQM [3:0]	SDRAM data enable
$\overline{\text{CSD0}}$	SDRAM Chip-select signal which is multiplexed with the $\overline{\text{CS2}}$ signal. These two signals are selectable by programming the system control register.
$\overline{\text{CSD1}}$	SDRAM Chip-select signal which is multiplexed with $\overline{\text{CS3}}$ signal. These two signals are selectable by programming the system control register. By default, $\overline{\text{CSD1}}$ is selected, so it can be used as boot chip-select by properly configuring BOOT [3:0] input pins.
$\overline{\text{RAS}}$	SDRAM Row Address Select signal
$\overline{\text{CAS}}$	SDRAM Column Address Select signal
$\overline{\text{SDWE}}$	SDRAM Write Enable signal
SDCKE0	SDRAM Clock Enable 0
SDCKE1	SDRAM Clock Enable 1
SDCLK	SDRAM Clock
$\overline{\text{RESET\_SF}}$	Not Used
<b>Clocks and Resets</b>	
EXTAL16M	Crystal input (4 MHz to 16 MHz), or a 16 MHz oscillator input when the internal oscillator circuit is shut down.
XTAL16M	Crystal output
EXTAL32K	32 kHz crystal input
XTAL32K	32 kHz crystal output
CLKO	Clock Out signal selected from internal clock signals.
$\overline{\text{RESET\_IN}}$	Master Reset—External active low Schmitt trigger input signal. When this signal goes active, all modules (except the reset module and the clock control module) are reset.
$\overline{\text{RESET\_OUT}}$	Reset Out—Internal active low output signal from the Watchdog Timer module and is asserted from the following sources: Power-on reset, External reset ( $\overline{\text{RESET\_IN}}$ ), and Watchdog time-out.
POR	Power On Reset—Internal active high Schmitt trigger input signal. The POR signal is normally generated by an external RC circuit designed to detect a power-up event.

**Table 2. i.MXL Signal Descriptions (Continued)**

Signal Name	Function/Notes
<b>JTAG</b>	
$\overline{\text{TRST}}$	Test Reset Pin—External active low signal used to asynchronously initialize the JTAG controller.
$\overline{\text{TDO}}$	Serial Output for test instructions and data. Changes on the falling edge of TCK.
TDI	Serial Input for test instructions and data. Sampled on the rising edge of TCK.
TCK	Test Clock to synchronize test logic and control register access through the JTAG port.
TMS	Test Mode Select to sequence the JTAG test controller's state machine. Sampled on the rising edge of TCK.
<b>DMA</b>	
DMA_REQ	DMA Request—external DMA request signal. Multiplexed with SPI1_SPI_RDY.
BIG_ENDIAN	Big Endian—Input signal that determines the configuration of the external chip-select space. If it is driven logic-high at reset, the external chip-select space will be configured to big endian. If it is driven logic-low at reset, the external chip-select space will be configured to little endian. This input must not change state after power-on reset negates or during chip operation.
<b>ETM</b>	
ETMTRACESYNC	ETM sync signal which is multiplexed with A24. ETMTRACESYNC is selected in ETM mode.
ETMTRACECLK	ETM clock signal which is multiplexed with A23. ETMTRACECLK is selected in ETM mode.
ETMPIESTAT [2:0]	ETM status signals which are multiplexed with A [22:20]. ETMPIESTAT [2:0] are selected in ETM mode.
ETMTRACEPKT [7:0]	ETM packet signals which are multiplexed with $\overline{\text{ECB}}$ , $\overline{\text{LBA}}$ , BCLK (burst clock), PA17, A [19:16]. ETMTRACEPKT [7:0] are selected in ETM mode.
<b>CMOS Sensor Interface</b>	
CSI_D [7:0]	Sensor port data
CSI_MCLK	Sensor port master clock
CSI_VSYNC	Sensor port vertical sync
CSI_HSYNC	Sensor port horizontal sync
CSI_PIXCLK	Sensor port data latch clock
<b>LCD Controller</b>	
LD [15:0]	LCD Data Bus—All LCD signals are driven low after reset and when LCD is off.
FLM/VSYNC	Frame Sync or Vsync—This signal also serves as the clock signal output for the gate driver (dedicated signal SPS for Sharp panel HR-TFT).
LP/HSYNC	Line pulse or H sync
LSCLK	Shift clock
ACD/OE	Alternate crystal direction/output enable.
CONTRAST	This signal is used to control the LCD bias voltage as contrast control.
SPL_SPR	Program horizontal scan direction (Sharp panel dedicated signal).
PS	Control signal output for source driver (Sharp panel dedicated signal).

Table 2. i.MXL Signal Descriptions (Continued)

Signal Name	Function/Notes
CLS	Start signal output for gate driver. This signal is an inverted version of PS (Sharp panel dedicated signal).
REV	Signal for common electrode driving signal preparation (Sharp panel dedicated signal).
<b>SPI 1 and SPI 2</b>	
SPI1_MOSI	Master Out/Slave In
SPI1_MISO	Slave In/Master Out
SPI1_ $\overline{SS}$	Slave Select (Selectable polarity)
SPI1_SCLK	Serial Clock
SPI1_ $\overline{SPI\_RDY}$	Serial Data Ready
SPI2_TXD	SPI2 Master TxData Output—This signal is multiplexed with a GPIO pin yet shows up as a primary or alternative signal in the signal multiplex scheme table. Please refer to the SPI and GPIO chapters in the <i>MC9328MXL Reference Manual</i> for information about how to bring this signal to the assigned pin.
SPI2_RXD	SPI2 Master RxData Input—This signal is multiplexed with a GPIO pin yet shows up as a primary or alternative signal in the signal multiplex scheme table. Please refer to the SPI and GPIO chapters in the <i>MC9328MXL Reference Manual</i> for information about how to bring this signal to the assigned pin.
SPI2_ $\overline{SS}$	SPI2 Slave Select—This signal is multiplexed with a GPIO pin yet shows up as a primary or alternative signal in the signal multiplex scheme table. Please refer to the SPI and GPIO chapters in the <i>MC9328MXL Reference Manual</i> for information about how to bring this signal to the assigned pin.
SPI2_SCLK	SPI2 Serial Clock—This signal is multiplexed with a GPIO pin yet shows up as a primary or alternative signal in the signal multiplex scheme table. Please refer to the SPI and GPIO chapters in the <i>MC9328MXL Reference Manual</i> for information about how to bring this signal to the assigned pin.
<b>General Purpose Timers</b>	
TIN	Timer Input Capture or Timer Input Clock—The signal on this input is applied to both timers simultaneously.
TMR2OUT	Timer 2 Output
<b>USB Device</b>	
USBD_VMO	USB Minus Output
USBD_VPO	USB Plus Output
USBD_VM	USB Minus Input
USBD_VP	USB Plus Input
USBD_SUSPND	USB Suspend Output
USBD_RCV	USB Receive Data
$\overline{USBD\_ROE}$	USB $\overline{OE}$
USBD_AFE	USB Analog Front End Enable
<b>Secure Digital Interface</b>	
SD_CMD	SD Command—If the system designer does not wish to make use of the internal pull-up, via the Pull-up enable register, a 4.7K–69K external pull up resistor must be added.
SD_CLK	MMC Output Clock

**Table 2. i.MXL Signal Descriptions (Continued)**

Signal Name	Function/Notes
SD_DAT [3:0]	Data—If the system designer does not wish to make use of the internal pull-up, via the Pull-up enable register, a 50K–69K external pull up resistor must be added.
<b>Memory Stick Interface</b>	
MS_BS	Memory Stick Bus State (Output)—Serial bus control signal
MS_SDIO	Memory Stick Serial Data (Input/Output)
MS_SCLKO	Memory Stick Serial Clock (Input)—Serial protocol clock source for SCLK Divider
MS_SCLKI	Memory Stick External Clock (Output)—Test clock input pin for SCLK divider. This pin is only for test purposes, not for use in application mode.
MS_PI0	General purpose Input0—Can be used for Memory Stick Insertion/Extraction detect
MS_PI1	General purpose Input1—Can be used for Memory Stick Insertion/Extraction detect
<b>UARTs – IrDA/Auto-Bauding</b>	
UART1_RXD	Receive Data
UART1_TXD	Transmit Data
$\overline{\text{UART1\_RTS}}$	Request to Send
$\overline{\text{UART1\_CTS}}$	Clear to Send
UART2_RXD	Receive Data
UART2_TXD	Transmit Data
$\overline{\text{UART2\_RTS}}$	Request to Send
$\overline{\text{UART2\_CTS}}$	Clear to Send
$\overline{\text{UART2\_DSR}}$	Data Set Ready
$\overline{\text{UART2\_RI}}$	Ring Indicator
$\overline{\text{UART2\_DCD}}$	Data Carrier Detect
$\overline{\text{UART2\_DTR}}$	Data Terminal Ready
<b>Serial Audio Port – SSI (configurable to I<sup>2</sup>S protocol)</b>	
SSI_TXDAT	Transmit Data
SSI_RXDAT	Receive Data
SSI_TXCLK	Transmit Serial Clock
SSI_RXCLK	Receive Serial Clock
SSI_TXFS	Transmit Frame Sync
SSI_RXFS	Receive Frame Sync
<b>I<sup>2</sup>C</b>	
I2C_SCL	I <sup>2</sup> C Clock
I2C_SDA	I <sup>2</sup> C Data



Table 2. i.MXL Signal Descriptions (Continued)

Signal Name	Function/Notes
<b>PWM</b>	
PWMO	PWM Output
<b>Test Function</b>	
TRISTATE	Forces all I/O signals to high impedance for test purposes. For normal operation, terminate this input with a 1 k ohm resistor to ground. (TRI-STATE® is a registered trademark of National Semiconductor.)
<b>Digital Supply Pins</b>	
NVDD	Digital Supply for the I/O pins
NVSS	Digital Ground for the I/O pins
<b>Supply Pins – Analog Modules</b>	
AVDD	Supply for analog blocks
<b>Internal Power Supply</b>	
QVDD	Power supply pins for silicon internal circuitry
QVSS	Ground pins for silicon internal circuitry

## 2.1 I/O Pads Power Supply and Signal Multiplexing Scheme

This section describes detailed information about both the power supply for each I/O pin and its function multiplexing scheme. The user can reference information provided in [Table 6 on page 18](#) to configure the power supply scheme for each device in the system (memory and external peripherals). The function multiplexing information also shown in [Table 6](#) allows the user to select the function of each pin by configuring the appropriate GPIO registers when those pins are multiplexed to provide different functions.

Table 3. MC9328MXLMC9328MXS Signal Multiplexing Scheme

I/O Supply Voltage	225 BGA Ball	256 BGA Ball	Primary			Alternate		GPIO		AIN	BIN	AOUT	Default
			Signal	Dir	Pull-Up	Signal	Dir	Mux	Pull-Up				
NVDD1	D2	B1	A24	O		ETMTRAC ESYNC	O	PA0	69K	SPI2_ SCLK			A24
NVDD1	C1	C2	D31	I/O	69K								
NVDD1	D1	C1	A23	O		ETMTRAC ECLK	O	PA31	69K				A23
NVDD1	E3	D2	D30	I/O	69K								
NVDD1	E2	D1	A22	O		ETMPIPE STAT2	O	PA30	69K				A22
NVDD1	E4	D3	D29	I/O	69K								
NVDD1	E1	E2	A21	O		ETMPIPE STAT1	O	PA29	69K				A21
NVDD1	F3	E3	D28	I/O	69K								

**Table 3. MC9328MXLMC9328MXS Signal Multiplexing Scheme (Continued)**

I/O Supply Voltage	225 BGA Ball	256 BGA Ball	Primary			Alternate		GPIO		AIN	BIN	AOUT	Default
			Signal	Dir	Pull-Up	Signal	Dir	Mux	Pull-Up				
NVDD1	F1	E1	A20	O		ETMPIPE STAT0	O	PA28	69K				A20
NVDD1	F4	F2	D27	I/O	69K								
NVDD1	F2	F4	A19	O		ETMTRAC EPKT3	O	PA27	69K				A19
NVDD1	G3	E4	D26	I/O	69K								
NVDD1	G2	F1	A18	O		ETMTRAC EPKT2	O	PA26	69K				A18
NVDD1	G4	F3	D25	I/O	69K								
NVDD1	G1	G2	A17	O		ETMTRAC EPKT1	O	PA25	69K				A17
NVDD1	H4	G3	D24	I/O	69K								
NVDD1	H2	F5	A16	O		ETMTRAC EPKT0	O	PA24	69K				A16
NVDD1	H3	G4	D23	I/O	69K								
NVDD1	H1	G1	A15	O									
NVDD1	H5	H2	D22	I/O	69K								
NVDD1	J1	H3	A14	O									
NVDD1	J3	G5	D21	I/O	69K								
NVDD1	K1	H1	A13	O									
NVDD1	J4	H4	D20	I/O	69K								
NVDD1	J2	J1	A12	O									
NVDD1	K4	J4	D19	I/O	69K								
NVDD1	K2	J2	A11	O									
NVDD1	L4	J3	D18	I/O	69K								
NVDD1	L1	K1	A10	O									
NVDD1	L3	K4	D17	I/O	69K								
NVDD1	L2	K3	A9	O									
NVDD1	M1	K2	D16	I/O	69K								
NVDD1	N1	L1	A8	O									
NVDD1	M2	L4	D15	I/O	69K								
NVDD1	N2	L2	A7	O									
NVDD1	P1	L5	D14	I/O	69K								
NVDD1	R1	M4	A6	O									
NVDD1	M3	L3	D13	I/O	69K								
NVDD1	P2	M1	A5	O									
NVDD1	N3	M2	D12	I/O	69K								
NVDD1	P3	N1	A4	O									
NVDD1	R2	M3	D11	I/O	69K								

Table 3. MC9328MXLMC9328MXS Signal Multiplexing Scheme (Continued)

I/O Supply Voltage	225 BGA Ball	256 BGA Ball	Primary			Alternate		GPIO		AIN	BIN	AOUT	Default
			Signal	Dir	Pull-Up	Signal	Dir	Mux	Pull-Up				
NVDD1	N4	P3	$\overline{EB0}$	O									
NVDD1	M4	N3	D10	I/O	69K								
NVDD1	P4	P1	A3	O									
NVDD1	R3	N2	$\overline{EB1}$	O									
NVDD1	N5	P2	D9	I/O	69K								
NVDD1	R4	R1	$\overline{EB2}$	O									
NVDD1	P5	T2	A2	O									
NVDD1	M5	R2	$\overline{EB3}$	O									
NVDD1	N6	R5	D8	I/O	69K								
NVDD1	R5	T3	$\overline{OE}$	O									
NVDD1	P6	R3	A1	O									
NVDD1	L7	T4	$\overline{CS5}$	O				PA23	69K				PA23
NVDD1	R6	N4	D7	I/O	69K								
NVDD1	M7	R4	$\overline{CS4}$	O				PA22	69K				PA22
NVDD1	R7	N5	A0	O				PA21	69K				A0
NVDD1	N7	P4	$\overline{CS3}$	O		$\overline{CSD1}$							$\overline{CSD1}$
NVDD1	P7	P5	D6	I/O	69K								
NVDD1	K3	T5	$\overline{CS2}$	O		$\overline{CSD0}$							$\overline{CSD0}$
NVDD1	R8	M5	SDCLK	O									
NVDD1	M8	T6	$\overline{CS1}$	O									
NVDD1	N8	T7	$\overline{CS0}$	O									
NVDD1	P8	R6	D5	I/O	69K								
NVDD1	L9	P6	$\overline{ECB}$	I		ETMTRAC EPKT7		PA20	69K				$\overline{ECB}$
NVDD1	R9	N6	D4	I/O	69K								
NVDD1	R10	R7	$\overline{LBA}$	O		ETMTRAC EPKT6		PA19	69K				$\overline{LBA}$
NVDD1	R11	P8	D3	I/O	69K								
NVDD1	M9	R8	BCLK			ETMTRAC EPKT5		PA18	69K				BCLK
NVDD1	L8	P7	D2	I/O	69K								
NVDD1	N9	N7	PA17			ETMTRAC EPKT4		PA17	69K	SPI2_ SS		$\overline{DTACK}$	PA17
NVDD1	K10	N8	D1	I/O	69K								
NVDD1	M10	M7	$\overline{RW}$										
NVDD1	P10	T8	MA11	O									
NVDD1	P9	M8	MA10	O									
NVDD1	N10	R9	D0	I/O	69K								
NVDD1	R12	P9	DQM3	O									

**Table 3. MC9328MXLMC9328MXS Signal Multiplexing Scheme (Continued)**

I/O Supply Voltage	225 BGA Ball	256 BGA Ball	Primary			Alternate		GPIO		AIN	BIN	AOUT	Default
			Signal	Dir	Pull-Up	Signal	Dir	Mux	Pull-Up				
NVDD1	N11	T9	DQM2	O									
NVDD1	P11	N9	DQM1	O									
NVDD1	N12	R10	DQM0	O									
NVDD1	P12	M9	RAS	O									
NVDD1	R13	L8	CAS	O									
NVDD1	R14	T10	SDWE	O									
NVDD1	N13	R11	SDCKE0	O									
NVDD1	P13	P10	SDCKE1	O									
NVDD1	P15	N10	RESET_SF	O									
NVDD1	P14	T11	CLKO	O									
AVDD1	R15	T12	AVDD1	Static									
QVDD2	M13	R15	QVDD2	Static									
AVDD1	N15	P13	TRST	I	69K								
AVDD1	N14	T13	TRISTATE <sub>1</sub>	I									
AVDD1	M15	T14	EXTAL16M	I									
AVDD1	L14	T15	XTAL16M	O									
AVDD1	L15	R16	EXTAL32K	I									
AVDD1	K15	P16	XTAL32K	O									
AVDD1	M14	M10	RESET_I <sub>N</sub> <sup>2</sup>	I	69K								
AVDD1	K14	N11	RESET_O <sub>UT</sub>	O									
AVDD1	L12	R12	POR <sup>2</sup>	I									
AVDD1	K13	M11	BIG_ENDI <sub>AN</sub> <sup>3</sup>	I									
AVDD1	M12	P11	BOOT3 <sup>3</sup>	I									
AVDD1	K11	N12	BOOT2 <sup>3</sup>	I									
AVDD1	J14	R13	BOOT1 <sup>3</sup>	I									
AVDD1	J15	P12	BOOT0 <sup>3</sup>	I									
NVDD2	J13	R14	TDO <sup>4</sup>	O									
NVDD2	H15	N15	TMS	I	69K								
NVDD2	J12	L9	TCK	I	69K								
NVDD2	K12	N16	TDI	I	69K								
NVDD2	J11	P14	I2C_SCL	O				PA16	69K				PA16
NVDD2	H14	P15	I2C_SDA	I/O				PA15	69K				PA15

Table 3. MC9328MXLMC9328MXS Signal Multiplexing Scheme (Continued)

I/O Supply Voltage	225 BGA Ball	256 BGA Ball	Primary			Alternate		GPIO		AIN	BIN	AOUT	Default
			Signal	Dir	Pull-Up	Signal	Dir	Mux	Pull-Up				
NVDD2	H13	N13	CSI_PIXCLK	I				PA14	69K				PA14
NVDD2	G14	M13	CSI_HSYNC	I				PA13	69K				PA13
NVDD2	H12	M14	CSI_VSYNC	I				PA12	69K				PA12
NVDD2	G13	N14	CSI_D7	I				PA11	69K				PA11
NVDD2	J10	M15	CSI_D6	I				PA10	69K				PA10
NVDD2	G15	M16	CSI_D5	I				PA9	69K				PA9
NVDD2	F15	M12	CSI_D4	I				PA8	69K				PA8
NVDD2	G12	L16	CSI_D3	I				PA7	69K				PA7
NVDD2	F14	L15	CSI_D2	I				PA6	69K				PA6
NVDD2	H11	L14	CSI_D1	I				PA5	69K				PA5
NVDD2	E14	L13	CSI_D0	I				PA4	69K				PA4
NVDD2	E15	L12	CSI_MCLK	O				PA3	69K				PA3
NVDD2	G11	L11	PWMO	O				PA2	69K				PA2
NVDD2	E13	L10	TIN	I				PA1	69K			SPI2_RXD_0	PA1
NVDD2	D14	K15	TMR2OUT	O				PD31	69K		SPI2_TXD		PD31
NVDD2	F13	K16	LD15	O				PD30	69K				PD30
NVDD2	F12	K14	LD14	O				PD29	69K				PD29
NVDD2	D15	K13	LD13	O				PD28	69K				PD28
NVDD2	C14	K12	LD12	O				PD27	69K				PD27
NVDD2	D13	J14	LD11	O				PD26	69K				PD26
NVDD2	E12	K11	LD10	O				PD25	69K				PD25
NVDD2	C13	H15	LD9	O				PD24	69K				PD24
NVDD2	C12	J13	LD8	O				PD23	69K				PD23
NVDD2	B15	J12	LD7	O				PD22	69K				PD22
NVDD2	B14	J11	LD6	O				PD21	69K				PD21
NVDD2	A15	H14	LD5	O				PD20	69K				PD20
NVDD2	A14	H13	LD4	O				PD19	69K				PD19
NVDD2	B13	H16	LD3	O				PD18	69K				PD18
NVDD2	A13	H12	LD2	O				PD17	69K				PD17
NVDD2	D12	G16	LD1	O				PD16	69K				PD16
NVDD2	B12	H11	LD0	O				PD15	69K				PD15
NVDD2	C11	G15	FLM_VSYNC	O				PD14	69K				PD14

**Table 3. MC9328MXLMC9328MXS Signal Multiplexing Scheme (Continued)**

I/O Supply Voltage	225 BGA Ball	256 BGA Ball	Primary			Alternate		GPIO		AIN	BIN	AOUT	Default
			Signal	Dir	Pull-Up	Signal	Dir	Mux	Pull-Up				
NVDD2	D11	G14	LP/HSYNC	O				PD13	69K				PD13
NVDD2	E11	G13	ACD/OE	O				PD12	69K				PD12
NVDD2	C10	G12	CONTRAST	O				PD11	69K				PD11
NVDD2	B11	F16	SPL_SPR	O		UART2_DS	O	PD10	69K	SPI2_TXD			PD10
NVDD2	A12	H10	PS	O		UART2_RI	O	PD9	69K			SPI2_RXD_1	PD9
NVDD2	F10	G11	CLS	O		UART2_CD	O	PD8	69K	SPI2_SS			PD8
NVDD2	A11	F12	REV	O		UART2_TR	I	PD7	69K	SPI2_SCLK			PD7
NVDD2	B10	F15	LSCLK	O				PD6	69K				PD6
NVDD3	D10	G9	SPI1_MOSI	I/O				PC17	69K				PC17
NVDD3	E10	F9	SPI1_MISO	I/O				PC16	69K				PC16
NVDD3	B9	E9	SPI1_SS	I/O				PC15	69K				PC15
NVDD3	A10	B9	SPI1_SCLK	I/O				PC14	69K				PC14
NVDD3	A9	D9	SPI1_SPI_RDY	I/O				PC13	69K			DMA_REQ	PC13
NVDD3	E8	A9	UART1_RXD	I				PC12	69K				PC12
NVDD3	B8	C9	UART1_TXD	O				PC11	69K				PC11
NVDD3	C9	A8	UART1_RTS	I				PC10	69K				PC10
NVDD3	E9	G8	UART1_CTS	O				PC9	69K				PC9
NVDD3	A8	B8	SSI_TXCLK	I/O				PC8	69K				PC8
NVDD3	C8	F8	SSI_TXFS	I/O				PC7	69K				PC7
NVDD3	F9	E8	SSI_TXDATA	O				PC6	69K				PC6
NVDD3	B7	D8	SSI_RXDATA	I				PC5	69K				PC5
NVDD3	F8	B7	SSI_RXCLK	I				PC4	69K				PC4
NVDD3	A7	C8	SSI_RXFS	I				PC3	69K				PC3
NVDD4	C7	C7	UART2_RXD	I				PB31	69K				PB31

**Table 3. MC9328MXLMC9328MXS Signal Multiplexing Scheme (Continued)**

I/O Supply Voltage	225 BGA Ball	256 BGA Ball	Primary			Alternate		GPIO		AIN	BIN	AOUT	Default
			Signal	Dir	Pull-Up	Signal	Dir	Mux	Pull-Up				
NVDD4	D8	F7	UART2_TXD	O				PB30	69K				PB30
NVDD4	E7	E7	UART2_RTS	I				PB29	69K				PB29
NVDD4	F7	C6	UART2_CTS	O				PB28	69K				PB28
NVDD4	B6	D7	USBD_VMO	O				PB27	69K				PB27
NVDD4	C6	D6	USBD_VPO	O				PB26	69K				PB26
NVDD4	A6	E6	USBD_VMI	I				PB25	69K				PB25
NVDD4	D6	B6	USBD_VPI	I				PB24	69K				PB24
NVDD4	A5	D5	USBD_SUSPND	O				PB23	69K				PB23
NVDD4	B5	C5	USBD_RCV	I/O				PB22	69K				PB22
NVDD4	A4	B5	USBD_ROE	O				PB21	69K				PB21
NVDD4	B4	A5	USBD_AFE	O				PB20	69K				PB20
NVDD4	A3	G7	PB19	I/O					69K				PB19
NVDD4	C4	F6	PB18	I/O					69K				PB18
NVDD4	D4	G6	PB17	O					69K				PB17
NVDD4	B3	B4	PB16	I					69K				PB16
NVDD4	A2	C4	PB15	I					69K				PB15
NVDD4	C3	D4	PB14	I					69K				PB14
NVDD4	A1	B3	SD_CMD	I/O		MS_BS		PB13	69K				PB13
NVDD4	B2	A3	SD_CLK	O		MS_SCLK_O		PB12	69K				PB12
NVDD4	B1	A2	SD_DAT3	I/O		MS_SDIO		PB11	69K (pull down)				PB11
NVDD4	C5	E5	SD_DAT2	I/O		MS_SCLK_I		PB10	69K				PB10
NVDD4	D3	B2	SD_DAT1	I/O		MS_PI1		PB9	69K				PB9
NVDD4	C2	C3	SD_DAT0	I/O		MS_PI0		PB8	69K				PB8
NVDD1	D5	K8	NVDD1	Static									
	G6	A1	NVSS	Static									
NVDD1	E5	H5	NVDD1	Static									
	H6	T1	NVSS	Static									
QVDD1	J8	H9	QVDD1	Static									
	E6	H8	QVSS	Static									

**Table 3. MC9328MXLMC9328MXS Signal Multiplexing Scheme (Continued)**

I/O Supply Voltage	225 BGA Ball	256 BGA Ball	Primary			Alternate		GPIO		AIN	BIN	AOUT	Default
			Signal	Dir	Pull-Up	Signal	Dir	Mux	Pull-Up				
NVDD1	F5	J5	NVDD	Static									
	J6	K6	NVSS	Static									
NVDD1	G5	K5	NVDD1	Static									
	K6	M6	NVSS	Static									
NVDD1	J5	H6	NVDD1	Static									
	H7	J7	NVSS	Static									
NVDD1	K5	L6	NVDD1	Static									
	J7	J7	NVSS	Static									
NVDD1	L5	L6	NVDD1	Static									
	G8	K7	NVSS	Static									
NVDD1	L5	J8	NVDD1	Static									
	H8	L7	NVSS	Static									
	K7	T16	QVSS	Static									
NVDD2	H10	K10	NVDD2	Static									
	G9	J10	NVSS	Static									
QVDD3	F11	J15	QVDD3	Static									
	G10	J16	QVSS	Static									
NVDD2	C15	K9	NVDD2	Static									
	H9	J9	NVSS	Static									
QVDD4	D7	A13	QVDD4	Static									
	L13	B13	QVSS	Static									
NVDD3	D9	A10	NVDD3	Static									
	J9	A7	NVSS	Static									
	K9	A4	NVSS	Static									
NVDD4	G7	A6	NVDD4	Static									
NVDD1	F6		NVDD1	Static									
NVDD1	L6		NVDD1	Static									
NVDD1	M6		NVDD1	Static									
NVDD1	K8		NVDD1	Static									
	L10		NVSS	Static									
	L11		NVSS	Static									
	M11		NVSS	Static									

- <sup>1</sup> Pull down this input with 1KΩ resistor to GND.
- <sup>2</sup> External circuit required to drive this input.
- <sup>3</sup> Tie this input high (to AVDD) or pull down with 1KΩ resistor to GND.
- <sup>4</sup> Pull up this output with a resistor to NVDD2.



## 3 Electrical Characteristics

This section contains the electrical specifications and timing diagrams for the i.MXL processor.

### 3.1 Maximum Ratings

Table 4 provides information on maximum ratings which are those values beyond which damage to the device may occur. Functional operation should be restricted to the limits listed in Recommended Operating Range Table 5 on page 18 or the DC Characteristics table.

**Table 4. Maximum Ratings**

Symbol	Rating	Minimum	Maximum	Unit
NV <sub>DD</sub>	DC I/O Supply Voltage	-0.3	3.3	V
QV <sub>DD</sub>	DC Internal (core = 150 MHz) Supply Voltage	-0.3	1.9	V
QV <sub>DD</sub>	DC Internal (core = 200 MHz) Supply Voltage	-0.3	2.0	V
AV <sub>DD</sub>	DC Analog Supply Voltage	-0.3	3.3	V
BTRFV <sub>DD</sub>	DC Bluetooth Supply Voltage	-0.3	3.3	V
VESD_HBM	ESD immunity with HBM (human body model)	–	2000	V
VESD_MM	ESD immunity with MM (machine model)	–	100	V
ILatchup	Latch-up immunity	–	200	mA
Test	Storage temperature	-55	150	°C
Pmax	Power Consumption	800 <sup>1</sup>	1300 <sup>2</sup>	mW

<sup>1</sup> A typical application with 30 pads simultaneously switching assumes the GPIO toggling and instruction fetches from the ARM<sup>®</sup> core—that is, 7x GPIO, 15x Data bus, and 8x Address bus.

<sup>2</sup> A worst-case application with 70 pads simultaneously switching assumes the GPIO toggling and instruction fetches from the ARM core—that is, 32x GPIO, 30x Data bus, 8x Address bus. These calculations are based on the core running its heaviest OS application at 200MHz, and where the whole image is running out of SDRAM. QVDD at 2.0V, NVDD and AVDD at 3.3V, therefore, 180mA is the worst measurement recorded in the factory environment, max 5mA is consumed for OSC pads, with each toggle GPIO consuming 4mA.

### 3.2 Recommended Operating Range

Table 5 provides the recommended operating ranges for the supply voltages and temperatures. The i.MXL processor has multiple pairs of VDD and VSS power supply and return pins. QVDD and QVSS pins are used for internal logic. All other VDD and VSS pins are for the I/O pads voltage supply, and each pair of VDD and VSS provides power to the enclosed I/O pads. This design allows different peripheral supply voltage levels in a system.

Because AVDD pins are supply voltages to the analog pads, it is recommended to isolate and noise-filter the AVDD pins from other VDD pins.

For more information about I/O pads grouping per VDD, please refer to Table 2 on page 4.

Table 5. Recommended Operating Range

Symbol	Rating	Minimum	Maximum	Unit
T <sub>A</sub>	Operating temperature range MC9328MXLVM20/MC9328MXLVM15 MC9328MXLVP20/MC9328MXLVP15	0	70	°C
T <sub>A</sub>	Operating temperature range MC9328MXLDVM20/MC9328MXLDVM15 MC9328MXLDVP20/MC9328MXLDVP15	-30	70	°C
T <sub>A</sub>	Operating temperature range MC9328MXLCVM15/ MC9328MXLCP15	-40	85	°C
NVDD	I/O supply voltage (if using MSHC, CSI, SPI, LCD, and USBd which are only 3 V interfaces)	2.70	3.30	V
NVDD	I/O supply voltage (if not using the peripherals listed above)	1.70	3.30	V
QVDD	Internal supply voltage (Core = 150 MHz)	1.70	1.90	V
QVDD	Internal supply voltage (Core = 200 MHz)	1.80	2.00	V
AVDD	Analog supply voltage	1.70	3.30	V

### 3.3 Power Sequence Requirements

For required power-up and power-down sequencing, please refer to the “Power-Up Sequence” section of application note AN2537 on the i.MX applications processor website.

### 3.4 DC Electrical Characteristics

Table 6 contains both maximum and minimum DC characteristics of the i.MXL processor.

Table 6. Maximum and Minimum DC Characteristics

Number or Symbol	Parameter	Min	Typical	Max	Unit
I <sub>op</sub>	Full running operating current at 1.8V for QVDD, 3.3V for NVDD/AVDD (Core = 96 MHz, System = 96 MHz, MPEG4 decoding playback from external memory card to both external SSI audio decoder and driving TFT display panel, and OS with MMU enabled memory system is running on external SDRAM).	–	QVDD at 1.8V = 120mA; NVDD+AVDD at 3.0V = 30mA	–	mA
Sidd <sub>1</sub>	Standby current (Core = 150 MHz, QVDD = 1.8V, temp = 25°C)	–	25	–	μA
Sidd <sub>2</sub>	Standby current (Core = 150 MHz, QVDD = 1.8V, temp = 55°C)	–	45	–	μA
Sidd <sub>3</sub>	Standby current (Core = 150 MHz, QVDD = 2.0V, temp = 25°C)	–	35	–	μA
Sidd <sub>4</sub>	Standby current (Core = 150 MHz, QVDD = 2.0V, temp = 55°C)	–	60	–	μA

Table 6. Maximum and Minimum DC Characteristics (Continued)

Number or Symbol	Parameter	Min	Typical	Max	Unit
V <sub>IH</sub>	Input high voltage	0.7V <sub>DD</sub>	–	V <sub>DD</sub> +0.2	V
V <sub>IL</sub>	Input low voltage	–	–	0.4	V
V <sub>OH</sub>	Output high voltage (I <sub>OH</sub> = 2.0 mA)	0.7V <sub>DD</sub>	–	V <sub>DD</sub>	V
V <sub>OL</sub>	Output low voltage (I <sub>OL</sub> = -2.5 mA)	–	–	0.4	V
I <sub>IL</sub>	Input low leakage current (V <sub>IN</sub> = GND, no pull-up or pull-down)	–	–	±1	μA
I <sub>IH</sub>	Input high leakage current (V <sub>IN</sub> = V <sub>DD</sub> , no pull-up or pull-down)	–	–	±1	μA
I <sub>OH</sub>	Output high current (V <sub>OH</sub> = 0.8V <sub>DD</sub> , V <sub>DD</sub> = 1.8V)	4.0	–	–	mA
I <sub>OL</sub>	Output low current (V <sub>OL</sub> = 0.4V, V <sub>DD</sub> = 1.8V)	-4.0	–	–	mA
I <sub>OZ</sub>	Output leakage current (V <sub>out</sub> = V <sub>DD</sub> , output is high impedance)	–	–	±5	μA
C <sub>i</sub>	Input capacitance	–	–	5	pF
C <sub>o</sub>	Output capacitance	–	–	5	pF

### 3.5 AC Electrical Characteristics

The AC characteristics consist of output delays, input setup and hold times, and signal skew times. All signals are specified relative to an appropriate edge of other signals. All timing specifications are specified at a system operating frequency from 0 MHz to 96 MHz (core operating frequency 150 MHz) with an operating supply voltage from V<sub>DD min</sub> to V<sub>DD max</sub> under an operating temperature from T<sub>L</sub> to T<sub>H</sub>. All timing is measured at 30 pF loading.

Table 7. Tristate Signal Timing

Pin	Parameter	Minimum	Maximum	Unit
TRISTATE	Time from TRISTATE activate until I/O becomes Hi-Z	–	20.8	ns

Table 8. 32k/16M Oscillator Signal Timing

Parameter	Minimum	RMS	Maximum	Unit
EXTAL32k input jitter (peak to peak)	–	5	20	ns
EXTAL32k startup time	800	–	–	ms
EXTAL16M input jitter (peak to peak) <sup>1</sup>	–	TBD	TBD	–
EXTAL16M startup time <sup>1</sup>	TBD	–	–	–

<sup>1</sup> The 16 MHz oscillator is not recommended for use in new designs.

## 4 Functional Description and Application Information

This section provides the electrical information including and timing diagrams for the individual modules of the i.MXL.

### 4.1 Embedded Trace Macrocell

All registers in the ETM9 are programmed through a JTAG interface. The interface is an extension of the ARM920T processor’s TAP controller, and is assigned scan chain 6. The scan chain consists of a 40-bit shift register comprised of the following:

- 32-bit data field
- 7-bit address field
- A read/write bit

The data to be written is scanned into the 32-bit data field, the address of the register into the 7-bit address field, and a 1 into the read/write bit.

A register is read by scanning its address into the address field and a 0 into the read/write bit. The 32-bit data field is ignored. A read or a write takes place when the TAP controller enters the UPDATE-DR state. The timing diagram for the ETM9 is shown in Figure 2. See Table 9 for the ETM9 timing parameters used in Figure 2.



Figure 2. Trace Port Timing Diagram

Table 9. Trace Port Timing Diagram Parameter Table

Ref No.	Parameter	1.8 ± 0.1 V		3.0 ± 0.3 V		Unit
		Minimum	Maximum	Minimum	Maximum	
1	CLK frequency	0	85	0	100	MHz
2a	Clock high time	1.3	–	2	–	ns
2b	Clock low time	3	–	2	–	ns
3a	Clock rise time	–	4	–	3	ns
3b	Clock fall time	–	3	–	3	ns

Table 9. Trace Port Timing Diagram Parameter Table (Continued)

Ref No.	Parameter	1.8 ± 0.1 V		3.0 ± 0.3 V		Unit
		Minimum	Maximum	Minimum	Maximum	
4a	Output hold time	2.28	–	2	–	ns
4b	Output setup time	3.42	–	3	–	ns

## 4.2 DPLL Timing Specifications

Parameters of the DPLL are given in Table 10. In this table,  $T_{ref}$  is a reference clock period after the pre-divider and  $T_{dck}$  is the output double clock period.

Table 10. DPLL Specifications

Parameter	Test Conditions	Minimum	Typical	Maximum	Unit
DPLL input clock freq range	$V_{cc} = 1.8V$	5	–	100	MHz
Pre-divider output clock freq range	$V_{cc} = 1.8V$	5	–	30	MHz
DPLL output clock freq range	$V_{cc} = 1.8V$	80	–	220	MHz
Pre-divider factor (PD)	–	1	–	16	–
Total multiplication factor (MF)	Includes both integer and fractional parts	5	–	15	–
MF integer part	–	5	–	15	–
MF numerator	Should be less than the denominator	0	–	1022	–
MF denominator	–	1	–	1023	–
Pre-multiplier lock-in time	–	–	–	312.5	$\mu\text{sec}$
Freq lock-in time after full reset	FOL mode for non-integer MF (does not include pre-multi lock-in time)	250	280 (56 $\mu\text{s}$ )	300	$T_{ref}$
Freq lock-in time after partial reset	FOL mode for non-integer MF (does not include pre-multi lock-in time)	220	250 (50 $\mu\text{s}$ )	270	$T_{ref}$
Phase lock-in time after full reset	FPL mode and integer MF (does not include pre-multi lock-in time)	300	350 (70 $\mu\text{s}$ )	400	$T_{ref}$
Phase lock-in time after partial reset	FPL mode and integer MF (does not include pre-multi lock-in time)	270	320 (64 $\mu\text{s}$ )	370	$T_{ref}$
Freq jitter (p-p)	–	–	0.005 (0.01%)	0.01	$2 \cdot T_{dck}$
Phase jitter (p-p)	Integer MF, FPL mode, $V_{cc}=1.8V$	–	1.0 (10%)	1.5	ns
Power supply voltage	–	1.7	–	2.5	V
Power dissipation	FOL mode, integer MF, $f_{dck} = 200 \text{ MHz}$ , $V_{cc} = 1.8V$	–	–	4	mW

### 4.3 Reset Module

The timing relationships of the Reset module with the POR and RESET\_IN are shown in Figure 3 and Figure 4.

**NOTE**

Be aware that NVDD must ramp up to at least 1.8V before QVDD is powered up to prevent forward biasing.

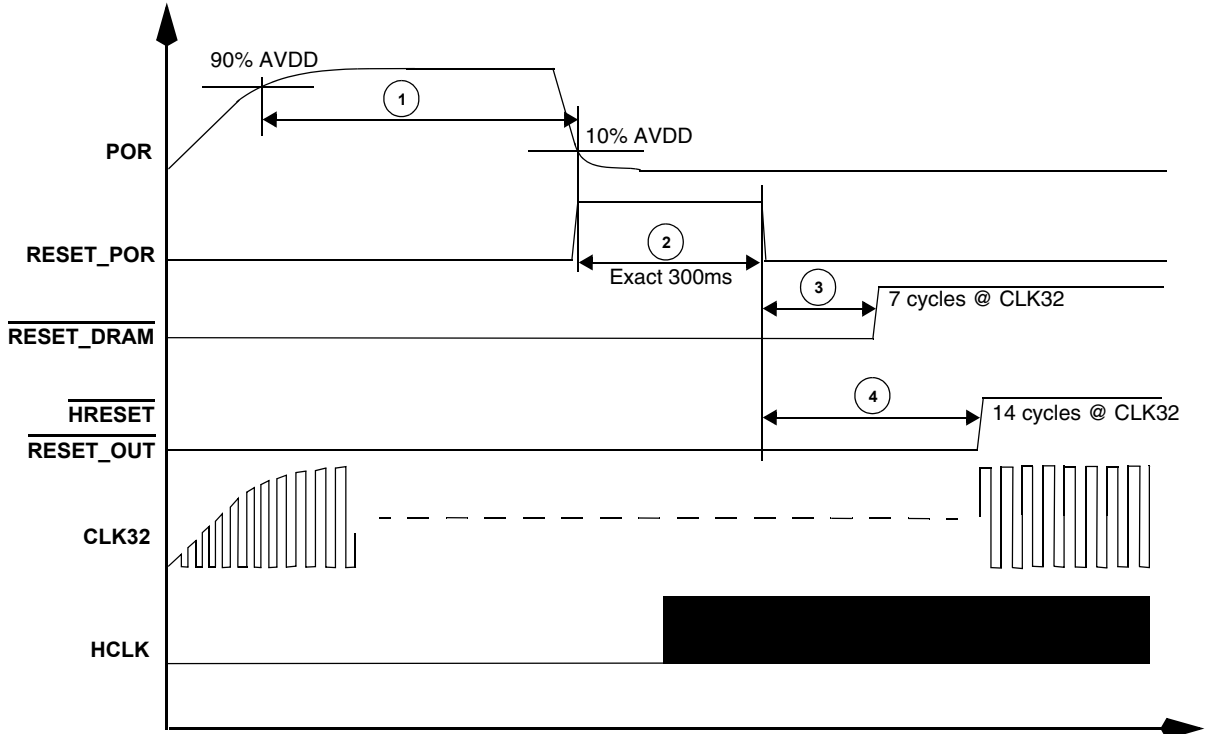

Figure 3. Timing Relationship with POR

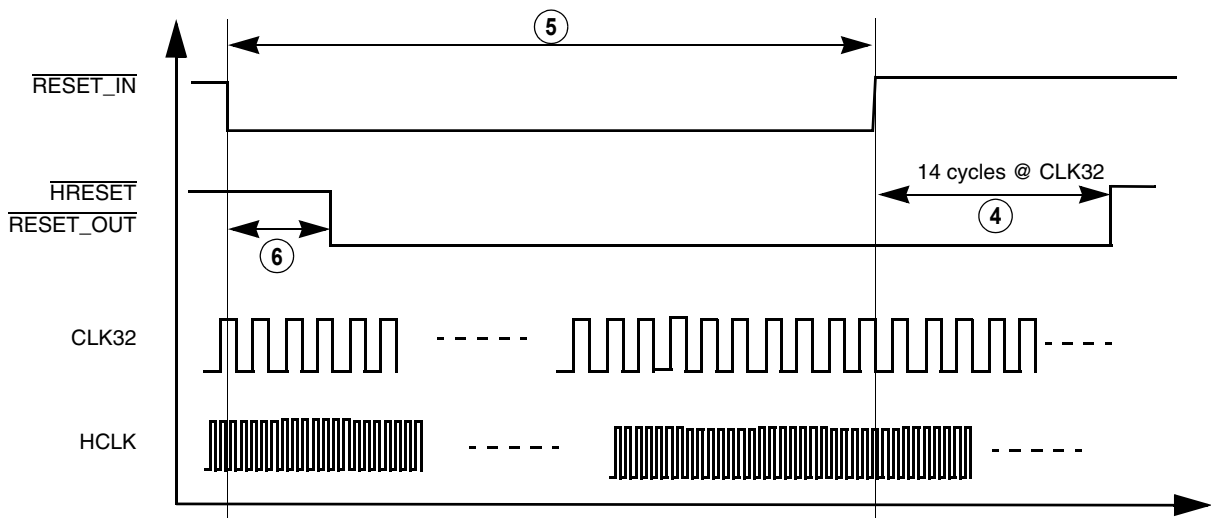

Figure 4. Timing Relationship with RESET\_IN

Table 11. Reset Module Timing Parameter Table

Ref No.	Parameter	1.8 ± 0.1 V		3.0 ± 0.3 V		Unit
		Min	Max	Min	Max	
1	Width of input POWER_ON_RESET	note <sup>1</sup>	–	note <sup>1</sup>	–	–
2	Width of internal $\overline{\text{POWER\_ON\_RESET}}$ (CLK32 at 32 kHz)	300	300	300	300	ms
3	7K to 32K-cycle stretcher for SDRAM reset	7	7	7	7	Cycles of CLK32
4	14K to 32K-cycle stretcher for internal system reset $\overline{\text{HRESET}}$ and output reset at pin $\overline{\text{RESET\_OUT}}$	14	14	14	14	Cycles of CLK32
5	Width of external hard-reset $\overline{\text{RESET\_IN}}$	4	–	4	–	Cycles of CLK32
6	4K to 32K-cycle qualifier	4	4	4	4	Cycles of CLK32

<sup>1</sup> POR width is dependent on the 32 or 32.768 kHz crystal oscillator start-up time. Design margin should allow for crystal tolerance, i.MX chip variations, temperature impact, and supply voltage influence. Through the process of supplying crystals for use with CMOS oscillators, crystal manufacturers have developed a working knowledge of start-up time of their crystals. Typically, start-up times range from 400 ms to 1.2 seconds for this type of crystal. If an external stable clock source (already running) is used instead of a crystal, the width of POR should be ignored in calculating timing for the start-up process.

## 4.4 External Interface Module

The External Interface Module (EIM) handles the interface to devices external to the i.MXL processor, including the generation of chip-selects for external peripherals and memory. The timing diagram for the EIM is shown in [Figure 5](#), and [Table 12](#) defines the parameters of signals.



Figure 5. EIM Bus Timing Diagram

Table 12. EIM Bus Timing Parameter Table

Ref No.	Parameter	1.8 ± 0.1 V			3.0 ± 0.3 V			Unit
		Min	Typical	Max	Min	Typical	Max	
1a	Clock fall to address valid	2.48	3.31	9.11	2.4	3.2	8.8	ns
1b	Clock fall to address invalid	1.55	2.48	5.69	1.5	2.4	5.5	ns
2a	Clock fall to chip-select valid	2.69	3.31	7.87	2.6	3.2	7.6	ns
2b	Clock fall to chip-select invalid	1.55	2.48	6.31	1.5	2.4	6.1	ns
3a	Clock fall to Read (Write) Valid	1.35	2.79	6.52	1.3	2.7	6.3	ns
3b	Clock fall to Read (Write) Invalid	1.86	2.59	6.11	1.8	2.5	5.9	ns



Table 12. EIM Bus Timing Parameter Table (Continued)

Ref No.	Parameter	1.8 ± 0.1 V			3.0 ± 0.3 V			Unit
		Min	Typical	Max	Min	Typical	Max	
4a	Clock <sup>1</sup> rise to Output Enable Valid	2.32	2.62	6.85	2.3	2.6	6.8	ns
4b	Clock <sup>1</sup> rise to Output Enable Invalid	2.11	2.52	6.55	2.1	2.5	6.5	ns
4c	Clock <sup>1</sup> fall to Output Enable Valid	2.38	2.69	7.04	2.3	2.6	6.8	ns
4d	Clock <sup>1</sup> fall to Output Enable Invalid	2.17	2.59	6.73	2.1	2.5	6.5	ns
5a	Clock <sup>1</sup> rise to Enable Bytes Valid	1.91	2.52	5.54	1.9	2.5	5.5	ns
5b	Clock <sup>1</sup> rise to Enable Bytes Invalid	1.81	2.42	5.24	1.8	2.4	5.2	ns
5c	Clock <sup>1</sup> fall to Enable Bytes Valid	1.97	2.59	5.69	1.9	2.5	5.5	ns
5d	Clock <sup>1</sup> fall to Enable Bytes Invalid	1.76	2.48	5.38	1.7	2.4	5.2	ns
6a	Clock <sup>1</sup> fall to Load Burst Address Valid	2.07	2.79	6.73	2.0	2.7	6.5	ns
6b	Clock <sup>1</sup> fall to Load Burst Address Invalid	1.97	2.79	6.83	1.9	2.7	6.6	ns
6c	Clock <sup>1</sup> rise to Load Burst Address Invalid	1.91	2.62	6.45	1.9	2.6	6.4	ns
7a	Clock <sup>1</sup> rise to Burst Clock rise	1.61	2.62	5.64	1.6	2.6	5.6	ns
7b	Clock <sup>1</sup> rise to Burst Clock fall	1.61	2.62	5.84	1.6	2.6	5.8	ns
7c	Clock <sup>1</sup> fall to Burst Clock rise	1.55	2.48	5.59	1.5	2.4	5.4	ns
7d	Clock <sup>1</sup> fall to Burst Clock fall	1.55	2.59	5.80	1.5	2.5	5.6	ns
8a	Read Data setup time	5.54	–	–	5.5	–	–	ns
8b	Read Data hold time	0	–	–	0	–	–	ns
9a	Clock <sup>1</sup> rise to Write Data Valid	1.81	2.72	6.85	1.8	2.7	6.8	ns
9b	Clock <sup>1</sup> fall to Write Data Invalid	1.45	2.48	5.69	1.4	2.4	5.5	ns
9c	Clock <sup>1</sup> rise to Write Data Invalid	1.63	–	–	1.62	–	–	ns
10a	$\overline{\text{DTACK}}$ setup time	2.52	–	–	2.5	–	–	ns

<sup>1</sup> Clock refers to the system clock signal, HCLK, generated from the System DPLL

#### 4.4.1 $\overline{\text{DTACK}}$ Signal Description

The  $\overline{\text{DTACK}}$  signal is the external input data acknowledge signal. When using the external  $\overline{\text{DTACK}}$  signal as a data acknowledge signal, the bus time-out monitor generates a bus error when a bus cycle is not terminated by the external  $\overline{\text{DTACK}}$  signal after 1022 HCLK counts have elapsed. Only the CS5 group supports DTACK signal function when the external DTACK signal is used for data acknowledgement.

#### 4.4.2 $\overline{\text{DTACK}}$ Signal Timing

Figure 6 through Figure 9 show the access cycle timing used by chip-select 5. The signal values and units of measure for this figure are found in the associated tables.

### 4.4.2.1 WAIT Read Cycle without DMA



Figure 6. WAIT Read Cycle without DMA

Table 13. WAIT Read Cycle without DMA: WSC = 111111, DTACK\_SEL=1, HCLK=96MHz

Number	Characteristic	3.0 ± 0.3 V		Unit
		Minimum	Maximum	
1	$\overline{OE}$ and $\overline{EB}$ assertion time	See note 2	–	ns
2	$\overline{CS5}$ pulse width	3T	–	ns
3	$\overline{OE}$ negated to address inactive	56.81	57.28	ns
4	Wait asserted after $\overline{OE}$ asserted	–	1020T	ns
5	Wait asserted to $\overline{OE}$ negated	2T+1.57	3T+7.33	ns
6	Data hold timing after $\overline{OE}$ negated	T-1.49	–	ns
7	Data ready after wait asserted	0	T	ns
8	OE negated to CS negated	1.5T-0.68	1.5T-0.06	ns
9	OE negated after EB negated	0.06	0.18	ns
10	Become low after CS5 asserted	0	1019T	ns
11	Wait pulse width	1T	1020T	ns

**Note:**

1. T is the system clock period. (For 96 MHz system clock, T=10.42 ns)
2.  $\overline{OE}$  and  $\overline{EB}$  assertion time is programmable by OEA bit in CS5L register.  $\overline{EB}$  assertion in read cycle will occur only when EBC bit in CS5L register is clear.
3. Address becomes valid and  $\overline{CS}$  asserts at the start of read access cycle.
4. The external wait input requirement is eliminated when CS5 is programmed to use internal wait state.

### 4.4.2.2 WAIT Read Cycle DMA Enabled



Figure 7. DTACK WAIT Read Cycle DMA Enabled

Table 14. DTACK WAIT Read Cycle DMA Enabled: WSC = 111111, DTACK\_SEL=1, HCLK=96MHz

Number	Characteristic	3.0 ± 0.3 V		Unit
		Minimum	Maximum	
1	$\overline{OE}$ and $\overline{EB}$ assertion time	See note 2	–	ns
2	$\overline{CS5}$ pulse width	3T	–	ns
3	$\overline{OE}$ negated before $\overline{CS5}$ is negated	1.5T-0.68	1.5T-0.06	ns
4	Address inactivated before $\overline{CS5}$ negated	–	0.05	ns
5	Wait asserted after $\overline{CS5}$ asserted	–	1020T	ns
6	Wait asserted to $\overline{OE}$ negated	2T+1.57	3T+7.33	ns
7	Data hold timing after $\overline{OE}$ negated	T-1.49	–	ns
8	Data ready after wait is asserted	–	T	ns
9	$\overline{CS5}$ deactive to next $\overline{CS5}$ active	T	–	ns
10	OE negate after EB negate	0.06	0.18	ns
11	Wait becomes low after CS5 asserted	0	1019T	ns

**Table 14. DTACK WAIT Read Cycle DMA Enabled: WSC = 111111, DTACK\_SEL=1, HCLK=96MHz (Continued)**

Number	Characteristic	3.0 ± 0.3 V		Unit
		Minimum	Maximum	
12	Wait pulse width	1T	1020T	ns

**Note:**

1. T is the system clock period. (For 96 MHz system clock, T=10.42 ns)
2.  $\overline{OE}$  and  $\overline{EB}$  assertion time is programmable by OEA bit in CS5L register.  $\overline{EB}$  assertion in read cycle will occur only when EBC bit in CS5L register is clear.
3. Address becomes valid and CS asserts at the start of read access cycle.
4. The external wait input requirement is eliminated when CS5 is programmed to use internal wait state.

**4.4.2.3 WAIT Write Cycle without DMA**

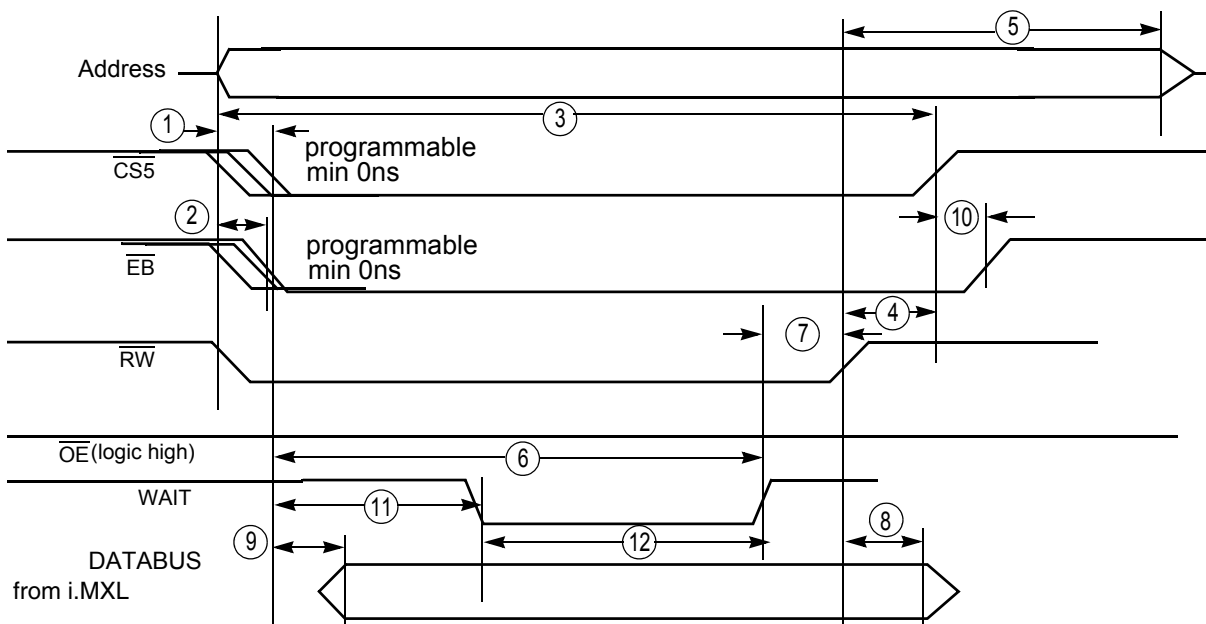

**Figure 8. WAIT Write Cycle without DMA**

**Table 15. WAIT Write Cycle without DMA: WSC = 111111, DTACK\_SEL=1, HCLK=96MHz**

Number	Characteristic	3.0 ± 0.3 V		Unit
		Minimum	Maximum	
1	$\overline{CS5}$ assertion time	See note 2	–	ns
2	$\overline{EB}$ assertion time	See note 2	–	ns
3	$\overline{CS5}$ pulse width	3T	–	ns
4	$\overline{RW}$ negated before $\overline{CS5}$ is negated	2.5T-3.63	2.5T-1.16	ns
5	$\overline{RW}$ negated to Address inactive	64.22	–	ns
6	Wait asserted after $\overline{CS5}$ asserted	–	1020T	ns

**Table 15. WAIT Write Cycle without DMA: WSC = 111111, DTACK\_SEL=1, HCLK=96MHz (Continued)**

Number	Characteristic	3.0 ± 0.3 V		Unit
		Minimum	Maximum	
7	Wait asserted to $\overline{RW}$ negated	$T+2.66$	$2T+7.96$	ns
8	Data hold timing after $\overline{RW}$ negated	$2T+0.03$	–	ns
9	Data ready after $\overline{CS5}$ is asserted	–	$T$	ns
10	$\overline{EB}$ negated after $\overline{CS5}$ is negated	$0.5T$	$0.5T+0.5$	ns
11	Wait becomes low after $\overline{CS5}$ asserted	0	$1019T$	ns
12	Wait pulse width	$1T$	$1020T$	ns

**Note:**

1. T is the system clock period. (For 96 MHz system clock, T=10.42 ns)
2.  $\overline{CS5}$  assertion can be controlled by CSA bits.  $\overline{EB}$  assertion can also be programmable by WEA bits in CS5L register.
3. Address becomes valid and  $\overline{RW}$  asserts at the start of write access cycle.
4. The external wait input requirement is eliminated when CS5 is programmed to use internal wait state.

**4.4.2.4 WAIT Write Cycle DMA Enabled**



**Figure 9. WAIT Write Cycle DMA Enabled**

**Table 16. WAIT Write Cycle DMA Enabled: WSC = 111111, DTACK\_SEL=1, HCLK=96MHz**

Number	Characteristic	3.0 ± 0.3 V		Unit
		Minimum	Maximum	
1	$\overline{CS5}$ assertion time	See note 2	–	ns
2	$\overline{EB}$ assertion time	See note 2	–	ns
3	$\overline{CS5}$ pulse width	3T	–	ns
4	$\overline{RW}$ negated before $\overline{CS5}$ is negated	2.5T-3.63	2.5T-1.16	ns
5	Address inactivated after $\overline{CS}$ negated	–	0.09	ns
6	Wait asserted after $\overline{CS5}$ asserted	–	1020T	ns
7	Wait asserted to $\overline{RW}$ negated	T+2.66	2T+7.96	ns
8	Data hold timing after $\overline{RW}$ negated	2T+0.03	–	ns
9	Data ready after $\overline{CS5}$ is asserted	–	T	ns
10	$\overline{CS}$ deactive to next $\overline{CS}$ active	T	–	ns
11	$\overline{EB}$ negate after $\overline{CS}$ negate	0.5T	0.5T+0.5	
12	Wait becomes low after $\overline{CS5}$ asserted	0	1019T	ns
13	Wait pulse width	1T	1020T	ns

**Note:**

1. T is the system clock period. (For 96 MHz system clock, T=10.42 ns)
2.  $\overline{CS5}$  assertion can be controlled by CSA bits.  $\overline{EB}$  assertion also can be programmable by WEA bits in CS5L register.
3. Address becomes valid and  $\overline{RW}$  asserts at the start of write access cycle.
4. The external wait input requirement is eliminated when  $\overline{CS5}$  is programmed to use internal wait state.

### 4.4.3 EIM External Bus Timing

The External Interface Module (EIM) is the interface to devices external to the i.MXL, including generation of chip-selects for external peripherals and memory. The timing diagram for the EIM is shown in [Figure 5](#), and [Table 12](#) defines the parameters of signals.



Note 1: x = 0, 1, 2 or 3

Note 2: EBC = Enable Byte Control bit (bit 11) on the Chip Select Control Register

**Figure 10. WSC = 1, A.HALF/E.HALF**



Figure 11. WSC = 1, WEA = 1, WEN = 1, A.HALF/E.HALF





Note 1: x = 0, 1, 2 or 3

Note 2: EBC = Enable Byte Control bit (bit 11) on the Chip Select Control Register

**Figure 12. WSC = 1, OEA = 1, A.WORD/E.HALF**



Figure 13. WSC = 1, WEA = 1, WEN = 2, A.WORD/E.HALF



Note 1: x = 0, 1, 2 or 3

Note 2: EBC = Enable Byte Control bit (bit 11) on the Chip Select Control Register

**Figure 14. WSC = 3, OEA = 2, A.WORD/E.HALF**



Figure 15. WSC = 3, WEA = 1, WEN = 3, A.WORD/E.HALF



Note 1: x = 0, 1, 2 or 3

Note 2: EBC = Enable Byte Control bit (bit 11) on the Chip Select Control Register

**Figure 16. WSC = 3, OEA = 4, A.WORD/E.HALF**



**Figure 17. WSC = 3, WEA = 2, WEN = 3, A.WORD/E.HALF**



Note 1: x = 0, 1, 2 or 3

Note 2: EBC = Enable Byte Control bit (bit 11) on the Chip Select Control Register

**Figure 18. WSC = 3, OEN = 2, A.WORD/E.HALF**



Note 1: x = 0, 1, 2 or 3

Note 2: EBC = Enable Byte Control bit (bit 11) on the Chip Select Control Register

**Figure 19. WSC = 3, OEA = 2, OEN = 2, A.WORD/E.HALF**





Figure 20. WSC = 2, WWS = 1, WEA = 1, WEN = 2, A.WORD/E.HALF



Figure 21. WSC = 1, WWS = 2, WEA = 1, WEN = 2, A.WORD/E.HALF



Note 1: x = 0, 1, 2 or 3

Note 2: EBC = Enable Byte Control bit (bit 11) on the Chip Select Control Register

**Figure 22. WSC = 2, WWS = 2, WEA = 1, WEN = 2, A.HALF/E.HALF**



Note 1: x = 0, 1, 2 or 3

Note 2: EBC = Enable Byte Control bit (bit 11) on the Chip Select Control Register

**Figure 23. WSC = 2, WWS = 1, WEA = 1, WEN = 2, EDC = 1, A.HALF/E.HALF**



Figure 24. WSC = 2, CSA = 1, WWS = 1, A.WORD/E.HALF



Note 1: x = 0, 1, 2 or 3  
 Note 2: EBC = Enable Byte Control bit (bit 11) on the Chip Select Control Register

**Figure 25. WSC = 3, CSA = 1, A.HALF/E.HALF**



Note 1: x = 0, 1, 2 or 3

Note 2: EBC = Enable Byte Control bit (bit 11) on the Chip Select Control Register

**Figure 26. WSC = 2, OEA = 2, CNC = 3, BCM = 1, A.HALF/E.HALF**



Note 1: x = 0, 1, 2 or 3

Note 2: EBC = Enable Byte Control bit (bit 11) on the Chip Select Control Register

**Figure 27. WSC = 2, OEA = 2, WEA = 1, WEN = 2, CNC = 3, A.HALF/E.HALF**





Note 1: x = 0, 1, 2 or 3  
 Note 2: EBC = Enable Byte Control bit (bit 11) on the Chip Select Control Register

**Figure 28. WSC = 3, SYNC = 1, A.HALF/E.HALF**



Note 1: x = 0, 1, 2 or 3

Note 2: EBC = Enable Byte Control bit (bit 11) on the Chip Select Control Register

**Figure 29. WSC = 2, SYNC = 1, DOL = [1/0], A.WORD/E.WORD**



Note 1: x = 0, 1, 2 or 3  
 Note 2: EBC = Enable Byte Control bit (bit 11) on the Chip Select Control Register

**Figure 30. WSC = 2, SYNC = 1, DOL = [1/0], A.WORD/E.HALF**



Note 1: x = 0, 1, 2 or 3

Note 2: EBC = Enable Byte Control bit (bit 11) on the Chip Select Control Register

**Figure 31. WSC = 7, OEA = 8, SYNC = 1, DOL = 1, BCD = 1, BCS = 2, A.WORD/E.HALF**



Note 1: x = 0, 1, 2 or 3

Note 2: EBC = Enable Byte Control bit (bit 11) on the Chip Select Control Register

**Figure 32. WSC = 7, OEA = 8, SYNC = 1, DOL = 1, BCD = 1, BCS = 1, A.WORD/E.HALF**

### 4.4.4 Non-TFT Panel Timing



Figure 33. Non-TFT Panel Timing

Table 17. Non TFT Panel Timing Diagram

Symbol	Parameter	Allowed Register Minimum Value <sup>1, 2</sup>	Actual Value	Unit
T1	HSYN to VSYN delay <sup>3</sup>	0	HWAIT2+2	Tpix <sup>4</sup>
T2	HSYN pulse width	0	HWIDTH+1	Tpix
T3	VSYN to SCLK	–	$0 \leq T3 \leq Ts^5$	–
T4	SCLK to HSYN	0	HWAIT1+1	Tpix

<sup>1</sup> Maximum frequency of LCDC\_CLK is 48 MHz, which is controlled by Peripheral Clock Divider Register.

<sup>2</sup> Maximum frequency of SCLK is HCLK / 5, otherwise LD output will be wrong.

<sup>3</sup> VSYN, HSYN and SCLK can be programmed as active high or active low. In the above timing diagram, all these 3 signals are active high.

<sup>4</sup> Tpix is the pixel clock period which equals LCDC\_CLK period \* (PCD + 1).

<sup>5</sup> Ts is the shift clock period. Ts = Tpix \* (panel data bus width).

## 4.5 SPI Timing Diagrams

To use the internal transmit (TX) and receive (RX) data FIFOs when the SPI 1 module is configured as a master, two control signals are used for data transfer rate control: the  $\overline{SS}$  signal (output) and the  $\overline{SPI\_RDY}$  signal (input). The SPI1 Sample Period Control Register (PERIODREG1) and the SPI2 Sample Period Control Register (PERIODREG2) can also be programmed to a fixed data transfer rate for either SPI 1 or SPI 2. When the SPI 1 module is configured as a slave, the user can configure the SPI1 Control Register (CONTROLREG1) to match the external SPI master's timing. In this configuration,  $\overline{SS}$  becomes an input signal, and is used to latch data into or load data out to the internal data shift registers, as well as to increment the data FIFO. Figure 34 through Figure 38 show the timing relationship of the master SPI using different triggering mechanisms.



**Figure 34. Master SPI Timing Diagram Using  $\overline{\text{SPI\_RDY}}$  Edge Trigger**



**Figure 35. Master SPI Timing Diagram Using  $\overline{\text{SPI\_RDY}}$  Level Trigger**



**Figure 36. Master SPI Timing Diagram Ignore  $\overline{\text{SPI\_RDY}}$  Level Trigger**

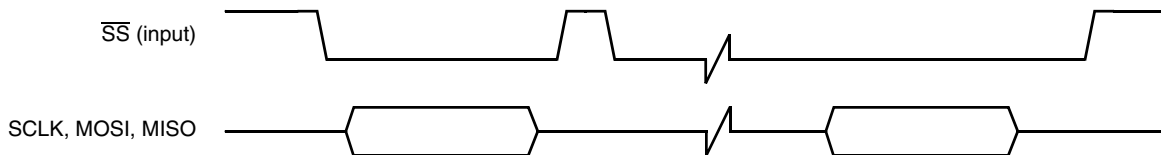

**Figure 37. Slave SPI Timing Diagram FIFO Advanced by BIT COUNT**



**Figure 38. Slave SPI Timing Diagram FIFO Advanced by  $\overline{\text{SS}}$  Rising Edge**

**Table 18. Timing Parameter Table for Figure 34 through Figure 38**

Ref No.	Parameter	3.0 ± 0.3 V		Unit
		Minimum	Maximum	
1	$\overline{\text{SPI\_RDY}}$ to $\overline{\text{SS}}$ output low	$2T^1$	–	ns
2	$\overline{\text{SS}}$ output low to first SCLK edge	$3 \cdot T_{\text{sclk}}^2$	–	ns
3	Last SCLK edge to $\overline{\text{SS}}$ output high	$2 \cdot T_{\text{sclk}}$	–	ns
4	$\overline{\text{SS}}$ output high to $\overline{\text{SPI\_RDY}}$ low	0	–	ns
5	$\overline{\text{SS}}$ output pulse width	$T_{\text{sclk}} + \text{WAIT}^3$	–	ns
6	$\overline{\text{SS}}$ input low to first SCLK edge	T	–	ns
7	$\overline{\text{SS}}$ input pulse width	T	–	ns

<sup>1</sup> T = CSPI system clock period (PERCLK2).

<sup>2</sup>  $T_{\text{sclk}}$  = Period of SCLK.

<sup>3</sup> WAIT = Number of bit clocks (SCLK) or 32.768 kHz clocks per Sample Period Control Register.



**Figure 39. SPI SCLK Timing Diagram**

**Table 19. Timing Parameter Table for SPI SCLK**

Ref No.	Parameter	3.0 ± 0.3 V		Unit
		Minimum	Maximum	
8	SCLK frequency	0	10	MHz
9	SCLK pulse width	100	–	ns

## 4.6 LCD Controller

This section includes timing diagrams for the LCD controller. For detailed timing diagrams of the LCD controller with various display configurations, refer to the LCD controller chapter of the *MC9328MXL Reference Manual*.



**Figure 40. SCLK to LD Timing Diagram**



**Table 20. LCDC SCLK Timing Parameter Table**

Ref No.	Parameter	3.0 ± 0.3 V		Unit
		Minimum	Maximum	
1	SCLK to LD valid	–	2	ns



**Figure 41. 4/8/16 Bit/Pixel TFT Color Mode Panel Timing**

**Table 21. 4/8/16 Bit/Pixel TFT Color Mode Panel Timing**

Symbol	Description	Minimum	Corresponding Register Value	Unit
T1	End of OE to beginning of VSYN	$T5+T6+T7+T9$	$(VWAIT1-T2)+T5+T6+T7+T9$	Ts
T2	HSYN period	$XMAX+5$	$XMAX+T5+T6+T7+T9+T10$	Ts
T3	VSYN pulse width	T2	$VWIDTH-(T2)$	Ts
T4	End of VSYN to beginning of OE	2	$VWAIT2-(T2)$	Ts
T5	HSYN pulse width	1	$HWIDTH+1$	Ts
T6	End of HSYN to beginning to T9	1	$HWAIT2+1$	Ts
T7	End of OE to beginning of HSYN	1	$HWAIT1+1$	Ts

**Table 21. 4/8/16 Bit/Pixel TFT Color Mode Panel Timing (Continued)**

Symbol	Description	Minimum	Corresponding Register Value	Unit
T8	SCLK to valid LD data	-3	3	ns
T9	End of HSYN idle2 to VSYN edge (for non-display region)	2	2	Ts
T9	End of HSYN idle2 to VSYN edge (for Display region)	1	1	Ts
T10	VSYN to OE active (Sharp = 0) when VWAIT2 = 0	1	1	Ts
T10	VSYN to OE active (Sharp = 1) when VWAIT2 = 0	2	2	Ts

**Note:**

- Ts is the SCLK period which equals  $LCDC\_CLK / (PCD + 1)$ . Normally  $LCDC\_CLK = 15ns$ .
- VSYN, HSYN and OE can be programmed as active high or active low. In [Figure 41](#), all 3 signals are active low.
- The polarity of SCLK and LD[15:0] can also be programmed.
- SCLK can be programmed to be deactivated during the VSYN pulse or the OE deasserted period. In [Figure 41](#), SCLK is always active.
- For T9 non-display region, VSYN is non-active. It is used as an reference.
- XMAX is defined in pixels.

## 4.7 Multimedia Card/Secure Digital Host Controller

The DMA interface block controls all data routing between the external data bus (DMA access), internal MMC/SD module data bus, and internal system FIFO access through a dedicated state machine that monitors the status of FIFO content (empty or full), FIFO address, and byte/block counters for the MMC/SD module (inner system) and the application (user programming).

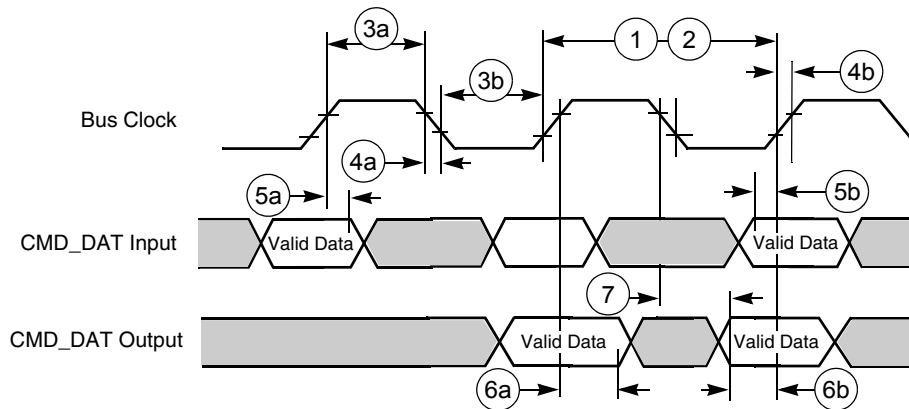

**Figure 42. Chip-Select Read Cycle Timing Diagram**

Table 22. SDHC Bus Timing Parameter Table

Ref No.	Parameter	1.8 ± 0.1 V		3.0 ± 0.3 V		Unit
		Minimum	Maximum	Minimum	Maximum	
1	CLK frequency at Data transfer Mode (PP) <sup>1</sup> —10/30 cards	0	25/5	0	25/5	MHz
2	CLK frequency at Identification Mode <sup>2</sup>	0	400	0	400	kHz
3a	Clock high time <sup>1</sup> —10/30 cards	6/33	–	10/50	–	ns
3b	Clock low time <sup>1</sup> —10/30 cards	15/75	–	10/50	–	ns
4a	Clock fall time <sup>1</sup> —10/30 cards	–	10/50 (5.00) <sup>3</sup>	–	10/50	ns
4b	Clock rise time <sup>1</sup> —10/30 cards	–	14/67 (6.67) <sup>3</sup>	–	10/50	ns
5a	Input hold time <sup>3</sup> —10/30 cards	10.3/10.3	–	9/9	–	ns
5b	Input setup time <sup>3</sup> —10/30 cards	10.3/10.3	–	9/9	–	ns
6a	Output hold time <sup>3</sup> —10/30 cards	5.7/5.7	–	5/5	–	ns
6b	Output setup time <sup>3</sup> —10/30 cards	5.7/5.7	–	5/5	–	ns
7	Output delay time <sup>3</sup>	0	16	0	14	ns

<sup>1</sup>  $C_L \leq 100$  pF / 250 pF (10/30 cards)

<sup>2</sup>  $C_L \leq 250$  pF (21 cards)

<sup>3</sup>  $C_L \leq 25$  pF (1 card)

#### 4.7.1 Command Response Timing on MMC/SD Bus

The card identification and card operation conditions timing are processed in open-drain mode. The card response to the host command starts after exactly  $N_{ID}$  clock cycles. For the card address assignment, SET\_RCA is also processed in the open-drain mode. The minimum delay between the host command and card response is NCR clock cycles as illustrated in Figure 43. The symbols for Figure 43 through Figure 47 are defined in Table 23.

Table 23. State Signal Parameters for Figure 43 through Figure 47

Card Active		Host Active	
Symbol	Definition	Symbol	Definition
Z	High impedance state	S	Start bit (0)
D	Data bits	T	Transmitter bit (Host = 1, Card = 0)
*	Repetition	P	One-cycle pull-up (1)
CRC	Cyclic redundancy check bits (7 bits)	E	End bit (1)



**Figure 43. Timing Diagrams at Identification Mode**

After a card receives its RCA, it switches to data transfer mode. As shown on the first diagram in [Figure 44](#), SD\_CMD lines in this mode are driven with push-pull drivers. The command is followed by a period of two Z bits (allowing time for direction switching on the bus) and then by P bits pushed up by the responding card. The other two diagrams show the separating periods  $N_{RC}$  and  $N_{CC}$ .

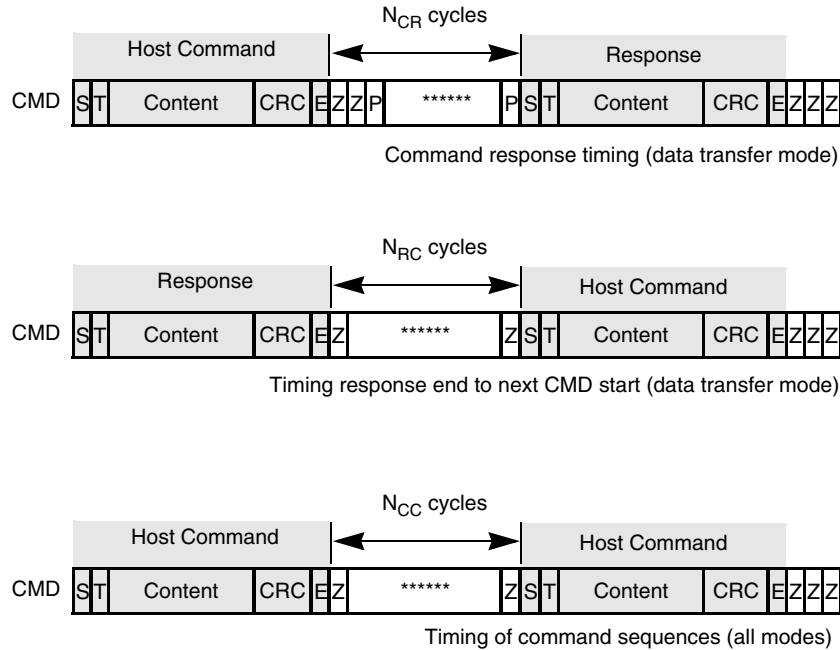

**Figure 44. Timing Diagrams at Data Transfer Mode**

[Figure 45](#) shows basic read operation timing. In a read operation, the sequence starts with a single block read command (which specifies the start address in the argument field). The response is sent on the SD\_CMD lines as usual. Data transmission from the card starts after the access time delay  $N_{AC}$ , beginning from the last bit of the read command. If the system is in multiple block read mode, the card sends a continuous flow of data blocks with distance  $N_{AC}$  until the card sees a stop transmission command. The data stops two clock cycles after the end bit of the stop command.



Figure 45. Timing Diagrams at Data Read

Figure 46 shows the basic write operation timing. As with the read operation, after the card response, the data transfer starts after  $N_{WR}$  cycles. The data is suffixed with CRC check bits to allow the card to check for transmission errors. The card sends back the CRC check result as a CC status token on the data line. If there was a transmission error, the card sends a negative CRC status (101); otherwise, a positive CRC status (010) is returned. The card expects a continuous flow of data blocks if it is configured to multiple block mode, with the flow terminated by a stop transmission command.

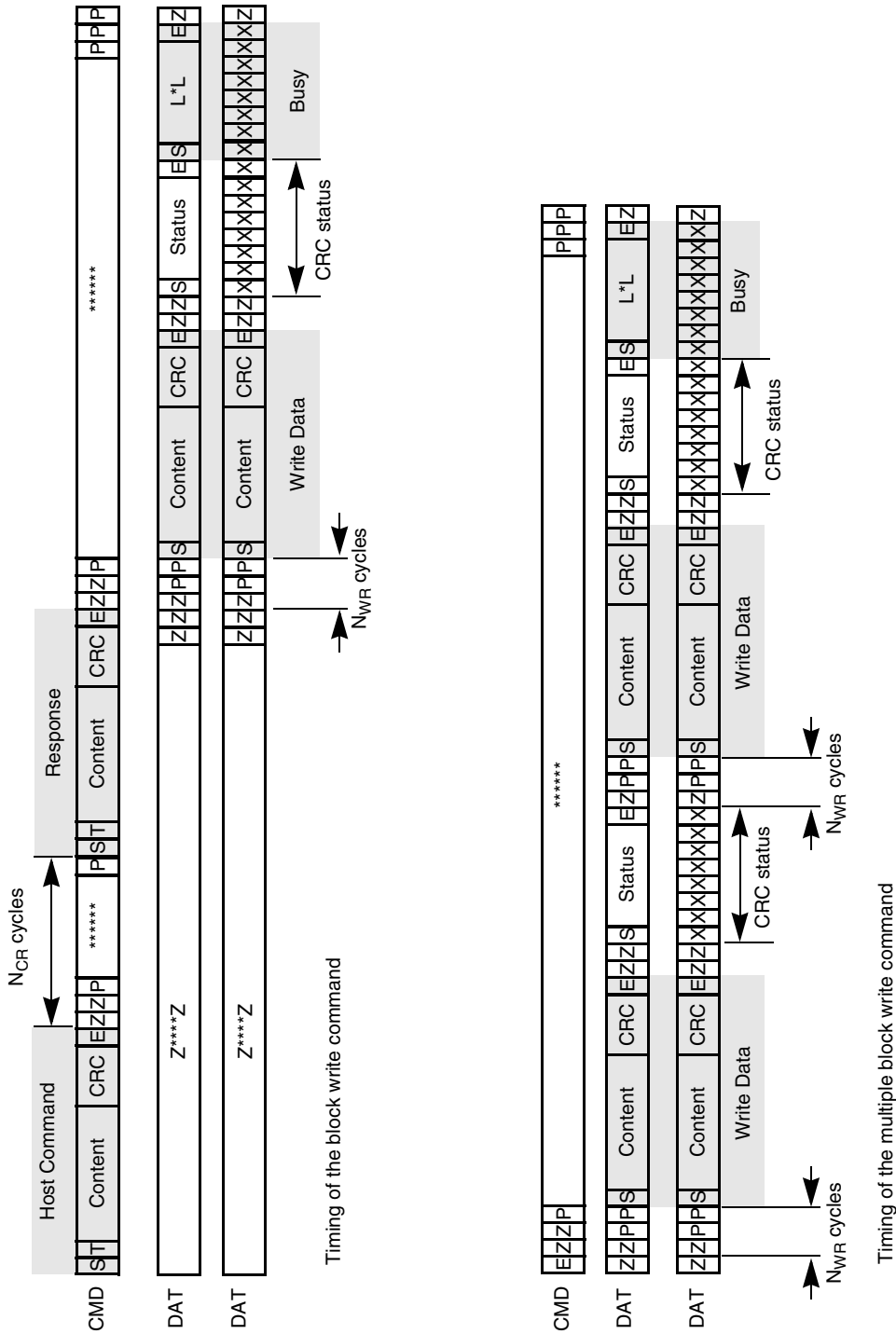

Figure 46. Timing Diagrams at Data Write

The stop transmission command may occur when the card is in different states. Figure 47 shows the different scenarios on the bus.

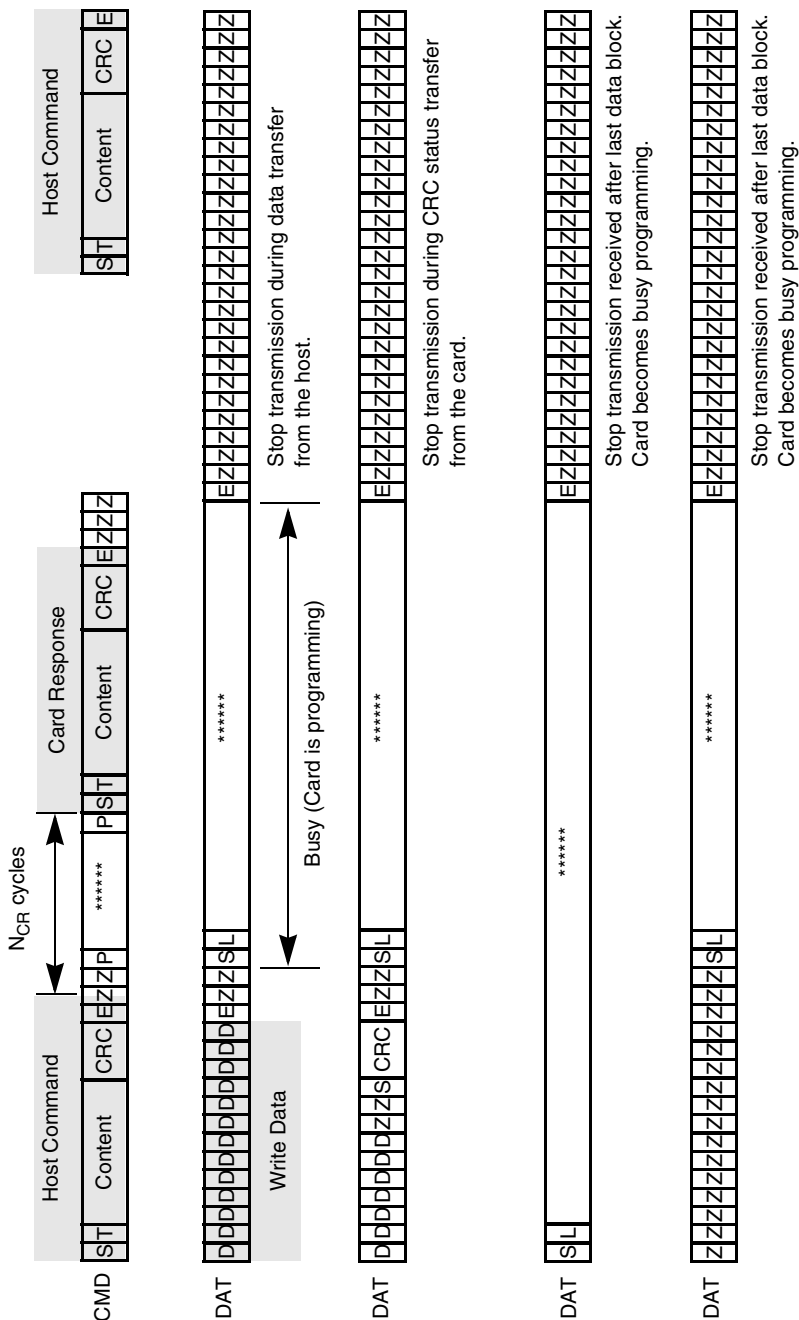

Figure 47. Stop Transmission During Different Scenarios

Table 24. Timing Values for Figure 43 through Figure 47

Parameter	Symbol	Minimum	Maximum	Unit
MMC/SD bus clock, CLK (All values are referred to minimum (VIH) and maximum (VIL))				
Command response cycle	NCR	2	64	Clock cycles
Identification response cycle	NID	5	5	Clock cycles
Access time delay cycle	NAC	2	TAAC + NSAC	Clock cycles

**Table 24. Timing Values for Figure 43 through Figure 47 (Continued)**

Parameter	Symbol	Minimum	Maximum	Unit
Command read cycle	NRC	8	–	Clock cycles
Command-command cycle	NCC	8	–	Clock cycles
Command write cycle	NWR	2	–	Clock cycles
Stop transmission cycle	NST	2	2	Clock cycles
TAAC: Data read access time -1 defined in CSD register bit[119:112]				
NSAC: Data read access time -2 in CLK cycles (NSAC:100) defined in CSD register bit[111:104]				

### 4.7.2 SDIO-IRQ and ReadWait Service Handling

In SDIO, there is a 1-bit or 4-bit interrupt response from the SDIO peripheral card. In 1-bit mode, the interrupt response is simply that the SD\_DAT[1] line is held low. The SD\_DAT[1] line is not used as data in this mode. The memory controller generates an interrupt according to this low and the system interrupt continues until the source is removed (SD\_DAT[1] returns to its high level).

In 4-bit mode, the interrupt is less simple. The interrupt triggers at a particular period called the “Interrupt Period” during the data access, and the controller must sample SD\_DAT[1] during this short period to determine the IRQ status of the attached card. The interrupt period only happens at the boundary of each block (512 bytes).



**Figure 48. SDIO IRQ Timing Diagram**

ReadWait is another feature in SDIO that allows the user to submit commands during the data transfer. In this mode, the block temporarily pauses the data transfer operation counter and related status, yet keeps the clock running, and allows the user to submit commands as normal. After all commands are submitted, the user can switch back to the data transfer operation and all counter and status values are resumed as access continues.



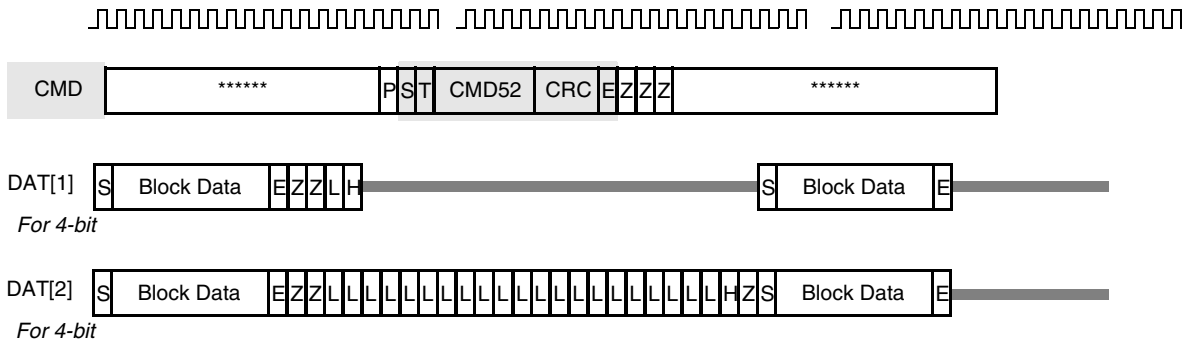

Figure 49. SDIO ReadWait Timing Diagram

## 4.8 Memory Stick Host Controller

The Memory Stick protocol requires three interface signal line connections for data transfers: MS\_BS, MS\_SDIO, and MS\_SCLKO. Communication is always initiated by the MSHC and operates the bus in either four-state or two-state access mode.

The MS\_BS signal classifies data on the SDIO into one of four states (BS0, BS1, BS2, or BS3) according to its attribute and transfer direction. BS0 is the INT transfer state, and during this state no packet transmissions occur. During the BS1, BS2, and BS3 states, packet communications are executed. The BS1, BS2, and BS3 states are regarded as one packet length and one communication transfer is always completed within one packet length (in four-state access mode).

The Memory Stick usually operates in four state access mode and in BS1, BS2, and BS3 bus states. When an error occurs during packet communication, the mode is shifted to two-state access mode, and the BS0 and BS1 bus states are automatically repeated to avoid a bus collision on the SDIO.



Figure 50. MSHC Signal Timing Diagram

Table 25. MSHC Signal Timing Parameter Table

Ref No.	Parameter	3.0 ± 0.3 V		Unit
		Minimum	Maximum	
1	MS_SCLKI frequency	–	25	MHz
2	MS_SCLKI high pulse width	20	–	ns
3	MS_SCLKI low pulse width	20	–	ns
4	MS_SCLKI rise time	–	3	ns
5	MS_SCLKI fall time	–	3	ns
6	MS_SCLKO frequency <sup>1</sup>	–	25	MHz
7	MS_SCLKO high pulse width <sup>1</sup>	20	–	ns
8	MS_SCLKO low pulse width <sup>1</sup>	15	–	ns
9	MS_SCLKO rise time <sup>1</sup>	–	5	ns
10	MS_SCLKO fall time <sup>1</sup>	–	5	ns
11	MS_BS delay time <sup>1</sup>	–	3	ns

Table 25. MSHC Signal Timing Parameter Table (Continued)

Ref No.	Parameter	3.0 ± 0.3 V		Unit
		Minimum	Maximum	
12	MS_SDIO output delay time <sup>1,2</sup>	–	3	ns
13	MS_SDIO input setup time for MS_SCLKO rising edge (RED bit = 0) <sup>3</sup>	18	–	ns
14	MS_SDIO input hold time for MS_SCLKO rising edge (RED bit = 0) <sup>3</sup>	0	–	ns
15	MS_SDIO input setup time for MS_SCLKO falling edge (RED bit = 1) <sup>4</sup>	23	–	ns
16	MS_SDIO input hold time for MS_SCLKO falling edge (RED bit = 1) <sup>4</sup>	0	–	ns

<sup>1</sup> Loading capacitor condition is less than or equal to 30pF.

<sup>2</sup> An external resistor (100 ~ 200 ohm) should be inserted in series to provide current control on the MS\_SDIO pin, because of a possibility of signal conflict between the MS\_SDIO pin and Memory Stick SDIO pin when the pin direction changes.

<sup>3</sup> If the MSC2[RED] bit = 0, MSHC samples MS\_SDIO input data at MS\_SCLKO rising edge.

<sup>4</sup> If the MSC2[RED] bit = 1, MSHC samples MS\_SDIO input data at MS\_SCLKO falling edge.

## 4.9 Pulse-Width Modulator

The PWM can be programmed to select one of two clock signals as its source frequency. The selected clock signal is passed through a divider and a prescaler before being input to the counter. The output is available at the pulse-width modulator output (PWMO) external pin. Its timing diagram is shown in [Figure 51](#) and the parameters are listed in [Table 26](#).



Figure 51. PWM Output Timing Diagram

Table 26. PWM Output Timing Parameter Table

Ref No.	Parameter	1.8 ± 0.1 V		3.0 ± 0.3 V		Unit
		Minimum	Maximum	Minimum	Maximum	
1	System CLK frequency <sup>1</sup>	0	87	0	100	MHz
2a	Clock high time <sup>1</sup>	3.3	–	5/10	–	ns
2b	Clock low time <sup>1</sup>	7.5	–	5/10	–	ns
3a	Clock fall time <sup>1</sup>	–	5	–	5/10	ns

**Table 26. PWM Output Timing Parameter Table (Continued)**

Ref No.	Parameter	1.8 ± 0.1 V		3.0 ± 0.3 V		Unit
		Minimum	Maximum	Minimum	Maximum	
3b	Clock rise time <sup>1</sup>	–	6.67	–	5/10	ns
4a	Output delay time <sup>1</sup>	5.7	–	5	–	ns
4b	Output setup time <sup>1</sup>	5.7	–	5	–	ns

<sup>1</sup> C<sub>L</sub> of PWMO = 30 pF

## 4.10 SDRAM Controller

This section shows timing diagrams and parameters associated with the SDRAM (synchronous dynamic random access memory) Controller.



**Figure 52. SDRAM Read Cycle Timing Diagram**

Table 27. SDRAM Read Timing Parameter Table

Ref No.	Parameter	1.8 ± 0.1 V		3.0 ± 0.3 V		Unit
		Minimum	Maximum	Minimum	Maximum	
1	SDRAM clock high-level width	2.67	–	4	–	ns
2	SDRAM clock low-level width	6	–	4	–	ns
3	SDRAM clock cycle time	11.4	–	10	–	ns
3S	CS, RAS, CAS, WE, DQM setup time	3.42	–	3	–	ns
3H	CS, RAS, CAS, WE, DQM hold time	2.28	–	2	–	ns
4S	Address setup time	3.42	–	3	–	ns
4H	Address hold time	2.28	–	2	–	ns
5	SDRAM access time (CL = 3)	–	6.84	–	6	ns
5	SDRAM access time (CL = 2)	–	6.84	–	6	ns
5	SDRAM access time (CL = 1)	–	22	–	22	ns
6	Data out hold time	2.85	–	2.5	–	ns
7	Data out high-impedance time (CL = 3)	–	6.84	–	6	ns
7	Data out high-impedance time (CL = 2)	–	6.84	–	6	ns
7	Data out high-impedance time (CL = 1)	–	22	–	22	ns
8	Active to read/write command period (RC = 1)	$t_{RCD}^1$	–	$t_{RCD1}$	–	ns

<sup>1</sup>  $t_{RCD}$  = SDRAM clock cycle time. This settings can be found in the *MC9328MXL reference manual*.



Figure 53. SDRAM Write Cycle Timing Diagram

Table 28. SDRAM Write Timing Parameter Table

Ref No.	Parameter	1.8 ± 0.1 V		3.0 ± 0.3 V		Unit
		Minimum	Maximum	Minimum	Maximum	
1	SDRAM clock high-level width	2.67	–	4	–	ns
2	SDRAM clock low-level width	6	–	4	–	ns
3	SDRAM clock cycle time	11.4	–	10	–	ns
4	Address setup time	3.42	–	3	–	ns
5	Address hold time	2.28	–	2	–	ns
6	Precharge cycle period <sup>1</sup>	$t_{RP}$ <sup>2</sup>	–	$t_{RP2}$	–	ns
7	Active to read/write command delay	$t_{RCD2}$	–	$t_{RCD2}$	–	ns
8	Data setup time	4.0	–	2	–	ns
9	Data hold time	2.28	–	2	–	ns

<sup>1</sup> Precharge cycle timing is included in the write timing diagram.

<sup>2</sup>  $t_{RP}$  and  $t_{RCD}$  = SDRAM clock cycle time. These settings can be found in the *MC9328MXL reference manual*.

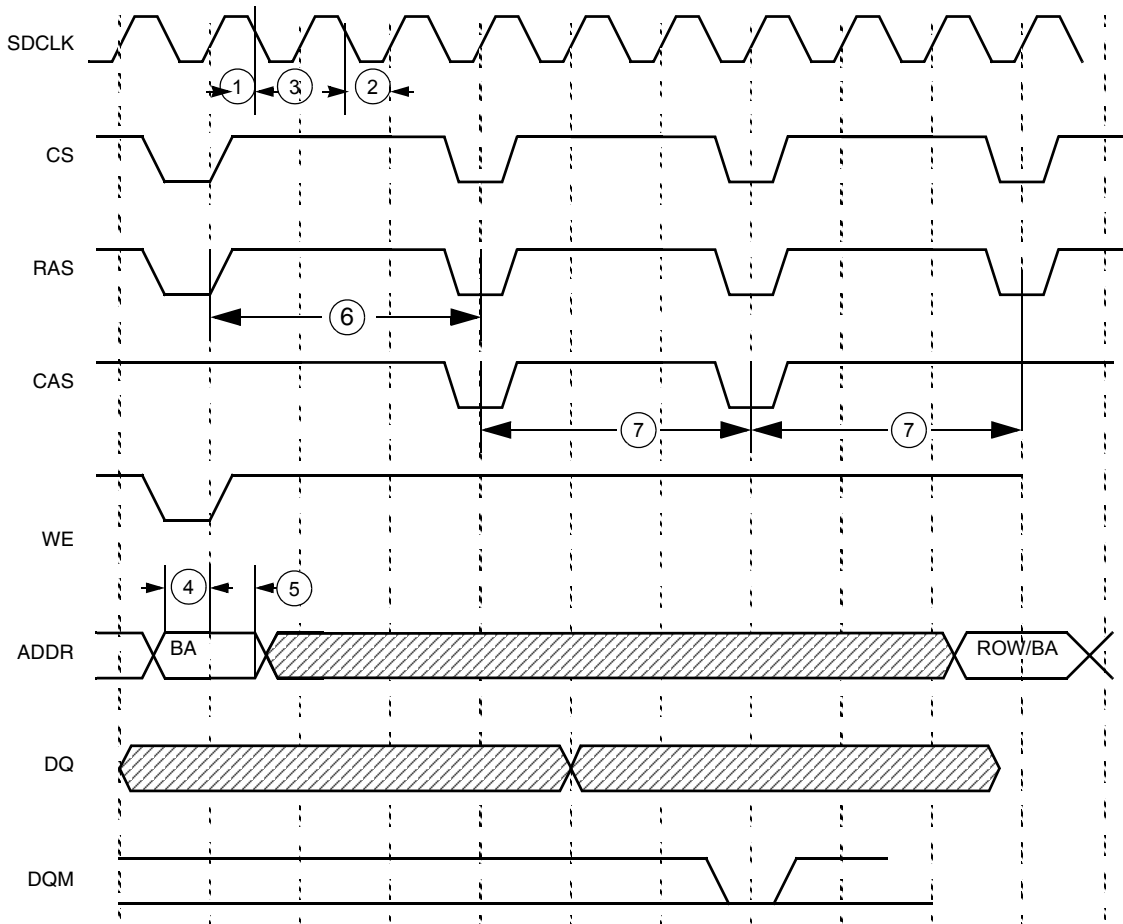

Figure 54. SDRAM Refresh Timing Diagram

Table 29. SDRAM Refresh Timing Parameter Table

Ref No.	Parameter	1.8 ± 0.1 V		3.0 ± 0.3 V		Unit
		Minimum	Maximum	Minimum	Maximum	
1	SDRAM clock high-level width	2.67	–	4	–	ns
2	SDRAM clock low-level width	6	–	4	–	ns
3	SDRAM clock cycle time	11.4	–	10	–	ns
4	Address setup time	3.42	–	3	–	ns
5	Address hold time	2.28	–	2	–	ns
6	Precharge cycle period	$t_{RP}^1$	–	$t_{RP1}$	–	ns
7	Auto precharge command period	$t_{RC1}$	–	$t_{RC1}$	–	ns

<sup>1</sup>  $t_{RP}$  and  $t_{RC}$  = SDRAM clock cycle time. These settings can be found in the *MC9328MXL reference manual*.

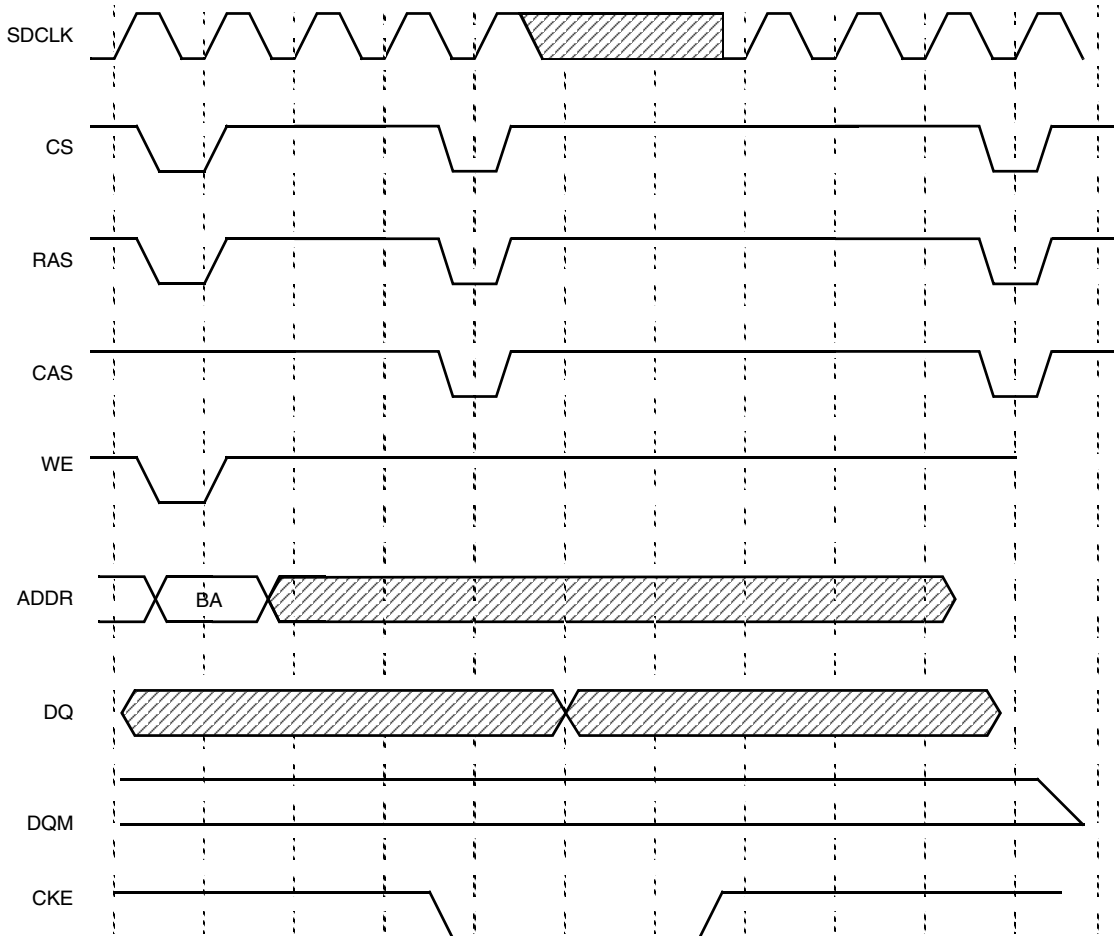

Figure 55. SDRAM Self-Refresh Cycle Timing Diagram

## 4.11 USB Device Port

Four types of data transfer modes exist for the USB module: control transfers, bulk transfers, isochronous transfers, and interrupt transfers. From the perspective of the USB module, the interrupt transfer type is identical to the bulk data transfer mode, and no additional hardware is supplied to support it. This section covers the transfer modes and how they work from the ground up.

Data moves across the USB in packets. Groups of packets are combined to form data transfers. The same packet transfer mechanism applies to bulk, interrupt, and control transfers. Isochronous data is also moved in the form of packets, however, because isochronous pipes are given a fixed portion of the USB bandwidth at all times, there is no end-of-transfer.





Figure 56. USB Device Timing Diagram for Data Transfer to USB Transceiver (TX)

Table 30. USB Device Timing Parameters for Data Transfer to USB Transceiver (TX)

Ref No.	Parameter	3.0 ± 0.3 V		Unit
		Minimum	Maximum	
1	t <sub>ROE_VPO</sub> ; USB_D_ROE active to USB_D_VPO low	83.14	83.47	ns
2	t <sub>ROE_VMO</sub> ; USB_D_ROE active to USB_D_VMO high	81.55	81.98	ns
3	t <sub>VPO_ROE</sub> ; USB_D_VPO high to USB_D_ROE deactivated	83.54	83.80	ns
4	t <sub>VMO_ROE</sub> ; USB_D_VMO low to USB_D_ROE deactivated (includes SE0)	248.90	249.13	ns
5	t <sub>FEOPT</sub> ; SE0 interval of EOP	160.00	175.00	ns
6	t <sub>PERIOD</sub> ; Data transfer rate	11.97	12.03	Mb/s



Figure 57. USB Device Timing Diagram for Data Transfer from USB Transceiver (RX)

Table 31. USB Device Timing Parameter Table for Data Transfer from USB Transceiver (RX)

Ref No.	Parameter	3.0 ± 0.3 V		Unit
		Minimum	Maximum	
1	t <sub>FEOPR</sub> ; Receiver SE0 interval of EOP	82	–	ns

## 4.12 I<sup>2</sup>C Module

The I<sup>2</sup>C communication protocol consists of seven elements: START, Data Source/Recipient, Data Direction, Slave Acknowledge, Data, Data Acknowledge, and STOP.



Figure 58. Definition of Bus Timing for I<sup>2</sup>C

Table 32. I<sup>2</sup>C Bus Timing Parameter Table

Ref No.	Parameter	1.8 ± 0.1 V		3.0 ± 0.3 V		Unit
		Minimum	Maximum	Minimum	Maximum	
1	Hold time (repeated) START condition	182	–	160	–	ns
2	Data hold time	0	171	0	150	ns
3	Data setup time	11.4	–	10	–	ns
4	HIGH period of the SCL clock	80	–	120	–	ns
5	LOW period of the SCL clock	480	–	320	–	ns
6	Setup time for STOP condition	182.4	–	160	–	ns

### 4.13 Synchronous Serial Interface

The transmit and receive sections of the SSI can be synchronous or asynchronous. In synchronous mode, the transmitter and the receiver use a common clock and frame synchronization signal. In asynchronous mode, the transmitter and receiver each have their own clock and frame synchronization signals. Continuous or gated clock mode can be selected. In continuous mode, the clock runs continuously. In gated clock mode, the clock functions only during transmission. The internal and external clock timing diagrams are shown in Figure 60 through Figure 62.

Normal or network mode can also be selected. In normal mode, the SSI functions with one data word of I/O per frame. In network mode, a frame can contain between 2 and 32 data words. Network mode is typically used in star or ring-time division multiplex networks with other processors or codecs, allowing interface to time division multiplexed networks without additional logic. Use of the gated clock is not allowed in network mode. These distinctions result in the basic operating modes that allow the SSI to communicate with a wide variety of devices.



**Note:** SRXD input in synchronous mode only.

**Figure 59. SSI Transmitter Internal Clock Timing Diagram**

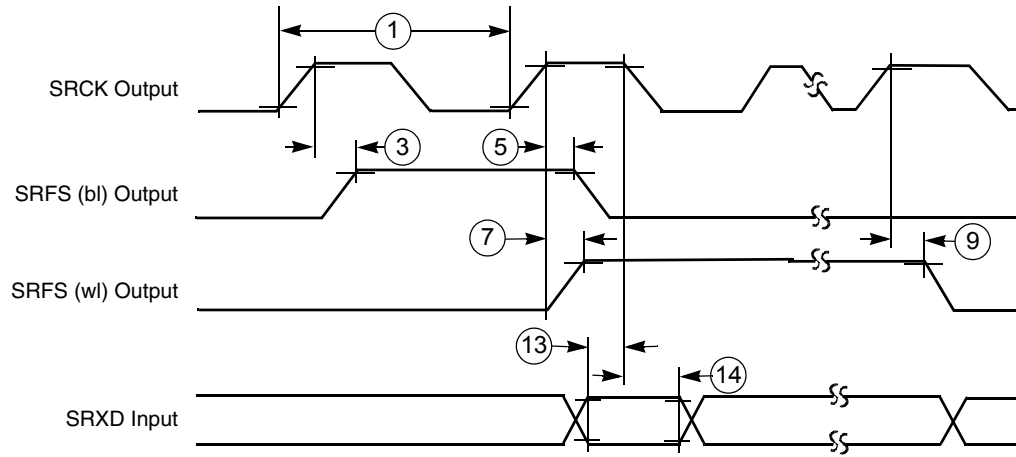
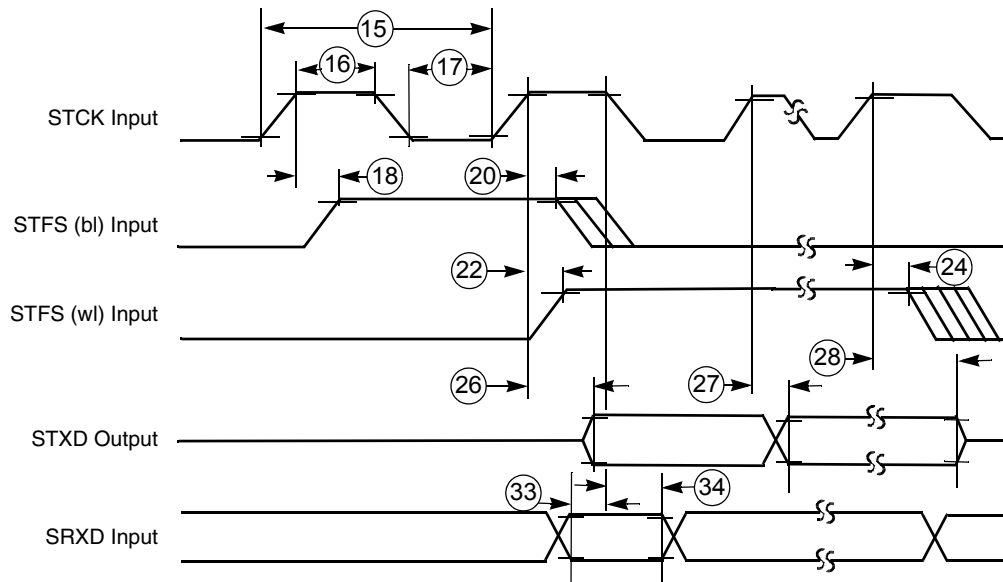

Figure 60. SSI Receiver Internal Clock Timing Diagram



Note: SRXD Input in Synchronous mode only

Figure 61. SSI Transmitter External Clock Timing Diagram



Figure 62. SSI Receiver External Clock Timing Diagram

Table 33. SSI (Port C Primary Function) Timing Parameter Table

Ref No.	Parameter	1.8 ± 0.1 V		3.0 ± 0.3 V		Unit
		Minimum	Maximum	Minimum	Maximum	
<b>Internal Clock Operation<sup>1</sup> (Port C Primary Function<sup>2</sup>)</b>						
1	STCK/SRCK clock period <sup>1</sup>	95	–	83.3	–	ns
2	STCK high to STFS (bl) high <sup>3</sup>	1.5	4.5	1.3	3.9	ns
3	SRCK high to SRFS (bl) high <sup>3</sup>	-1.2	-1.7	-1.1	-1.5	ns
4	STCK high to STFS (bl) low <sup>3</sup>	2.5	4.3	2.2	3.8	ns
5	SRCK high to SRFS (bl) low <sup>3</sup>	0.1	-0.8	0.1	-0.8	ns
6	STCK high to STFS (wl) high <sup>3</sup>	1.48	4.45	1.3	3.9	ns
7	SRCK high to SRFS (wl) high <sup>3</sup>	-1.1	-1.5	-1.1	-1.5	ns
8	STCK high to STFS (wl) low <sup>3</sup>	2.51	4.33	2.2	3.8	ns
9	SRCK high to SRFS (wl) low <sup>3</sup>	0.1	-0.8	0.1	-0.8	ns
10	STCK high to STXD valid from high impedance	14.25	15.73	12.5	13.8	ns
11a	STCK high to STXD high	0.91	3.08	0.8	2.7	ns
11b	STCK high to STXD low	0.57	3.19	0.5	2.8	ns
12	STCK high to STXD high impedance	12.88	13.57	11.3	11.9	ns
13	SRXD setup time before SRCK low	21.1	–	18.5	–	ns
14	SRXD hold time after SRCK low	0	–	0	–	ns
<b>External Clock Operation (Port C Primary Function<sup>2</sup>)</b>						
15	STCK/SRCK clock period <sup>1</sup>	92.8	–	81.4	–	ns
16	STCK/SRCK clock high period	27.1	–	40.7	–	ns
17	STCK/SRCK clock low period	61.1	–	40.7	–	ns

**Table 33. SSI (Port C Primary Function) Timing Parameter Table (Continued)**

Ref No.	Parameter	1.8 ± 0.1 V		3.0 ± 0.3 V		Unit
		Minimum	Maximum	Minimum	Maximum	
18	STCK high to STFS (bl) high <sup>3</sup>	–	92.8	0	81.4	ns
19	SRCK high to SRFS (bl) high <sup>3</sup>	–	92.8	0	81.4	ns
20	STCK high to STFS (bl) low <sup>3</sup>	–	92.8	0	81.4	ns
21	SRCK high to SRFS (bl) low <sup>3</sup>	–	92.8	0	81.4	ns
22	STCK high to STFS (wl) high <sup>3</sup>	–	92.8	0	81.4	ns
23	SRCK high to SRFS (wl) high <sup>3</sup>	–	92.8	0	81.4	ns
24	STCK high to STFS (wl) low <sup>3</sup>	–	92.8	0	81.4	ns
25	SRCK high to SRFS (wl) low <sup>3</sup>	–	92.8	0	81.4	ns
26	STCK high to STXD valid from high impedance	18.01	28.16	15.8	24.7	ns
27a	STCK high to STXD high	8.98	18.13	7.0	15.9	ns
27b	STCK high to STXD low	9.12	18.24	8.0	16.0	ns
28	STCK high to STXD high impedance	18.47	28.5	16.2	25.0	ns
29	SRXD setup time before SRCK low	1.14	–	1.0	–	ns
30	SRXD hole time after SRCK low	0	–	0	–	ns
<b>Synchronous Internal Clock Operation (Port C Primary Function<sup>2</sup>)</b>						
31	SRXD setup before STCK falling	15.4	–	13.5	–	ns
32	SRXD hold after STCK falling	0	–	0	–	ns
<b>Synchronous External Clock Operation (Port C Primary Function<sup>2</sup>)</b>						
33	SRXD setup before STCK falling	1.14	–	1.0	–	ns
34	SRXD hold after STCK falling	0	–	0	–	ns

<sup>1</sup> All the timings for the SSI are given for a non-inverted serial clock polarity (TSCKP/RSCKP = 0) and a non-inverted frame sync (TFSI/RFSI = 0). If the polarity of the clock and/or the frame sync have been inverted, all the timing remains valid by inverting the clock signal STCK/SRCK and/or the frame sync STFS/SRFS shown in the tables and in the figures.

<sup>2</sup> There are 2 sets of I/O signals for the SSI module. They are from Port C primary function (pad 257 to pad 261) and Port B alternate function (pad 283 to pad 288). When SSI signals are configured as outputs, they can be viewed both at Port C primary function and Port B alternate function. When SSI signals are configured as input, the SSI module selects the input based on status of the FMCR register bits in the Clock controller module (CRM). By default, the input are selected from Port C primary function.

<sup>3</sup> bl = bit length; wl = word length.

Table 34. SSI (Port B Alternate Function) Timing Parameter Table

Ref No.	Parameter	1.8 ± 0.1 V		3.0 ± 0.3 V		Unit
		Minimum	Maximum	Minimum	Maximum	
<b>Internal Clock Operation<sup>1</sup> (Port B Alternate Function<sup>2</sup>)</b>						
1	STCK/SRCK clock period <sup>1</sup>	95	–	83.3	–	ns
2	STCK high to STFS (bl) high <sup>3</sup>	1.7	4.8	1.5	4.2	ns
3	SRCK high to SRFS (bl) high <sup>3</sup>	-0.1	1.0	-0.1	1.0	ns
4	STCK high to STFS (bl) low <sup>3</sup>	3.08	5.24	2.7	4.6	ns
5	SRCK high to SRFS (bl) low <sup>3</sup>	1.25	2.28	1.1	2.0	ns
6	STCK high to STFS (wl) high <sup>3</sup>	1.71	4.79	1.5	4.2	ns
7	SRCK high to SRFS (wl) high <sup>3</sup>	-0.1	1.0	-0.1	1.0	ns
8	STCK high to STFS (wl) low <sup>3</sup>	3.08	5.24	2.7	4.6	ns
9	SRCK high to SRFS (wl) low <sup>3</sup>	1.25	2.28	1.1	2.0	ns
10	STCK high to STXD valid from high impedance	14.93	16.19	13.1	14.2	ns
11a	STCK high to STXD high	1.25	3.42	1.1	3.0	ns
11b	STCK high to STXD low	2.51	3.99	2.2	3.5	ns
12	STCK high to STXD high impedance	12.43	14.59	10.9	12.8	ns
13	SRXD setup time before SRCK low	20	–	17.5	–	ns
14	SRXD hold time after SRCK low	0	–	0	–	ns
<b>External Clock Operation (Port B Alternate Function<sup>2</sup>)</b>						
15	STCK/SRCK clock period <sup>1</sup>	92.8	–	81.4	–	ns
16	STCK/SRCK clock high period	27.1	–	40.7	–	ns
17	STCK/SRCK clock low period	61.1	–	40.7	–	ns
18	STCK high to STFS (bl) high <sup>3</sup>	–	92.8	0	81.4	ns
19	SRCK high to SRFS (bl) high <sup>3</sup>	–	92.8	0	81.4	ns
20	STCK high to STFS (bl) low <sup>3</sup>	–	92.8	0	81.4	ns
21	SRCK high to SRFS (bl) low <sup>3</sup>	–	92.8	0	81.4	ns
22	STCK high to STFS (wl) high <sup>3</sup>	–	92.8	0	81.4	ns
23	SRCK high to SRFS (wl) high <sup>3</sup>	–	92.8	0	81.4	ns
24	STCK high to STFS (wl) low <sup>3</sup>	–	92.8	0	81.4	ns
25	SRCK high to SRFS (wl) low <sup>3</sup>	–	92.8	0	81.4	ns
26	STCK high to STXD valid from high impedance	18.9	29.07	16.6	25.5	ns
27a	STCK high to STXD high	9.23	20.75	8.1	18.2	ns
27b	STCK high to STXD low	10.60	21.32	9.3	18.7	ns

Table 34. SSI (Port B Alternate Function) Timing Parameter Table (Continued)

Ref No.	Parameter	1.8 ± 0.1 V		3.0 ± 0.3 V		Unit
		Minimum	Maximum	Minimum	Maximum	
28	STCK high to STXD high impedance	17.90	29.75	15.7	26.1	ns
29	SRXD setup time before SRCK low	1.14	–	1.0	–	ns
30	SRXD hold time after SRCK low	0	–	0	–	ns
<b>Synchronous Internal Clock Operation (Port B Alternate Function<sup>2</sup>)</b>						
31	SRXD setup before STCK falling	18.81	–	16.5	–	ns
32	SRXD hold after STCK falling	0	–	0	–	ns
<b>Synchronous External Clock Operation (Port B Alternate Function<sup>2</sup>)</b>						
33	SRXD setup before STCK falling	1.14	–	1.0	–	ns
34	SRXD hold after STCK falling	0	–	0	–	ns

<sup>1</sup> All the timings for the SSI are given for a non-inverted serial clock polarity (TSCKP/RSCCKP = 0) and a non-inverted frame sync (TFSI/RFSI = 0). If the polarity of the clock and/or the frame sync have been inverted, all the timing remains valid by inverting the clock signal STCK/SRCK and/or the frame sync STFS/SRFS shown in the tables and in the figures.

<sup>2</sup> There are 2 set of I/O signals for the SSI module. They are from Port C primary function (pad 257 to pad 261) and Port B alternate function (pad 283 to pad 288). When SSI signals are configured as outputs, they can be viewed both at Port C primary function and Port B alternate function. When SSI signals are configured as inputs, the SSI module selects the input based on FMCR register bits in the Clock controller module (CRM). By default, the input are selected from Port C primary function.

<sup>3</sup> bl = bit length; wl = word length.

## 4.14 CMOS Sensor Interface

The CMOS Sensor Interface (CSI) module consists of a control register to configure the interface timing, a control register for statistic data generation, a status register, interface logic, a 32 × 32 image data receive FIFO, and a 16 × 32 statistic data FIFO.

### 4.14.1 Gated Clock Mode

Figure 63 shows the timing diagram when the CMOS sensor output data is configured for negative edge and the CSI is programmed to received data on the positive edge. Figure 64 shows the timing diagram when the CMOS sensor output data is configured for positive edge and the CSI is programmed to received data in negative edge. The parameters for the timing diagrams are listed in Table 35.



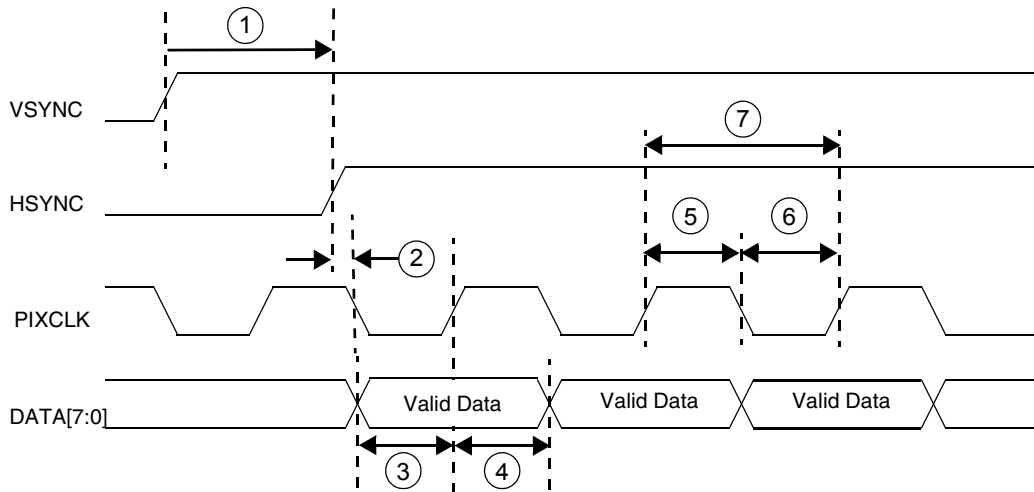

**Figure 63. Sensor Output Data on Pixel Clock Falling Edge  
CSI Latches Data on Pixel Clock Rising Edge**

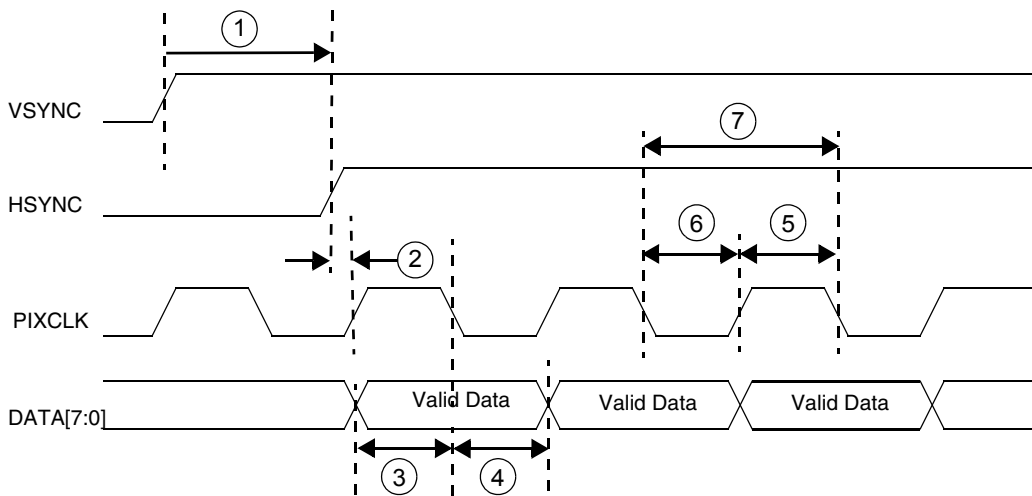

**Figure 64. Sensor Output Data on Pixel Clock Rising Edge  
CSI Latches Data on Pixel Clock Falling Edge**

**Table 35. Gated Clock Mode Timing Parameters**

Ref No.	Parameter	Min	Max	Unit
1	csi_vsync to csi_hsync	180	–	ns
2	csi_hsync to csi_pixclk	1	–	ns
3	csi_d setup time	1	–	ns
4	csi_d hold time	1	–	ns
5	csi_pixclk high time	10.42	–	ns
6	csi_pixclk low time	10.42	–	ns
7	csi_pixclk frequency	0	48	MHz

The limitation on pixel clock rise time / fall time are not specified. It should be calculated from the hold time and setup time, according to:

Rising-edge latch data

$$\begin{aligned} \text{max rise time allowed} &= (\text{positive duty cycle} - \text{hold time}) \\ \text{max fall time allowed} &= (\text{negative duty cycle} - \text{setup time}) \end{aligned}$$

In most of case, duty cycle is 50 / 50, therefore

$$\begin{aligned} \text{max rise time} &= (\text{period} / 2 - \text{hold time}) \\ \text{max fall time} &= (\text{period} / 2 - \text{setup time}) \end{aligned}$$

For example: Given pixel clock period = 10ns, duty cycle = 50 / 50, hold time = 1ns, setup time = 1ns.

$$\begin{aligned} \text{positive duty cycle} &= 10 / 2 = 5\text{ns} \\ \Rightarrow \text{max rise time allowed} &= 5 - 1 = 4\text{ns} \\ \text{negative duty cycle} &= 10 / 2 = 5\text{ns} \\ \Rightarrow \text{max fall time allowed} &= 5 - 1 = 4\text{ns} \end{aligned}$$

Falling-edge latch data

$$\begin{aligned} \text{max fall time allowed} &= (\text{negative duty cycle} - \text{hold time}) \\ \text{max rise time allowed} &= (\text{positive duty cycle} - \text{setup time}) \end{aligned}$$

### 4.14.2 Non-Gated Clock Mode

Figure 65 shows the timing diagram when the CMOS sensor output data is configured for negative edge and the CSI is programmed to received data on the positive edge. Figure 66 shows the timing diagram when the CMOS sensor output data is configured for positive edge and the CSI is programmed to received data in negative edge. The parameters for the timing diagrams are listed in Table 36.

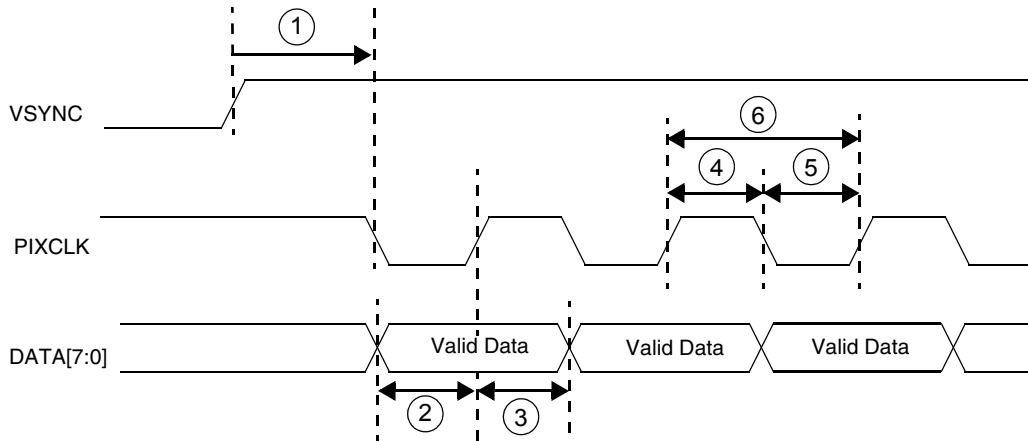

Figure 65. Sensor Output Data on Pixel Clock Falling Edge  
CSI Latches Data on Pixel Clock Rising Edge



**Figure 66. Sensor Output Data on Pixel Clock Rising Edge  
CSI Latches Data on Pixel Clock Falling Edge**

**Table 36. Non-Gated Clock Mode Parameters**

Ref No.	Parameter	Min	Max	Unit
1	csi_vsync to csi_pixclk	180	–	ns
2	csi_d setup time	1	–	ns
3	csi_d hold time	1	–	ns
4	csi_pixclk high time	10.42	–	ns
5	csi_pixclk low time	10.42	–	ns
6	csi_pixclk frequency	0	48	MHz

The limitation on pixel clock rise time / fall time are not specified. It should be calculated from the hold time and setup time, according to:

$$\begin{aligned} \text{max rise time allowed} &= (\text{positive duty cycle} - \text{hold time}) \\ \text{max fall time allowed} &= (\text{negative duty cycle} - \text{setup time}) \end{aligned}$$

In most of case, duty cycle is 50 / 50, therefore:

$$\begin{aligned} \text{max rise time} &= (\text{period} / 2 - \text{hold time}) \\ \text{max fall time} &= (\text{period} / 2 - \text{setup time}) \end{aligned}$$

For example: Given pixel clock period = 10ns, duty cycle = 50 / 50, hold time = 1ns, setup time = 1ns.

$$\begin{aligned} \text{positive duty cycle} &= 10 / 2 = 5\text{ns} \\ \Rightarrow \text{max rise time allowed} &= 5 - 1 = 4\text{ns} \\ \text{negative duty cycle} &= 10 / 2 = 5\text{ns} \\ \Rightarrow \text{max fall time allowed} &= 5 - 1 = 4\text{ns} \end{aligned}$$

Falling-edge latch data

$$\begin{aligned} \text{max fall time allowed} &= (\text{negative duty cycle} - \text{hold time}) \\ \text{max rise time allowed} &= (\text{positive duty cycle} - \text{setup time}) \end{aligned}$$

## 5 Pin-Out and Package Information

Table 37 illustrates the package pin assignments for the 256-pin MAPBGA package. For a complete listing of signals, see the Signal Multiplexing Table 3 on page 9.

**Table 37. i.MXL 256 MAPBGA Pin Assignments**

	1	2	3	4	5	6	7	8	9	10	11	12	13	14	15	16	
<b>A</b>	NVSS	SD_DAT3	SD_CLK	NVSS	USBD_AFE	NVDD4	NVSS	UART1_RTS	UART1_RXD	NVDD3	N.C.	N.C.	QVDD4	N.C.	N.C.	N.C.	<b>A</b>
<b>B</b>	A24	SD_DAT1	SD_CMD	PB16	USBD_ROE	USBD_VP	SSI_RXCLK	SSI_TXCLK	SPI1_SCLK	N.C.	N.C.	N.C.	QVSS	N.C.	N.C.	N.C.	<b>B</b>
<b>C</b>	A23	D31	SD_DAT0	PB15	USBD_RCV	UART2_CTS	UART2_RXD	SSI_RXFS	UART1_TXD	N.C.	N.C.	N.C.	N.C.	N.C.	N.C.	N.C.	<b>C</b>
<b>D</b>	A22	D30	D29	PB14	USBD_SUSPND	USBD_VPO	USBD_VMO	SSI_RXDAT	SPI1_SPI_RDY	N.C.	N.C.	N.C.	N.C.	N.C.	N.C.	N.C.	<b>D</b>
<b>E</b>	A20	A21	D28	D26	SD_DAT2	USBD_VM	UART2_RTS	SSI_TXDAT	SPI1_SS	N.C.	N.C.	N.C.	N.C.	N.C.	N.C.	N.C.	<b>E</b>
<b>F</b>	A18	D27	D25	A19	A16	PB18	UART2_TXD	SSI_TXFS	SPI1_MISO	N.C.	N.C.	REV	N.C.	N.C.	LSCLK	SPL_SPR	<b>F</b>
<b>G</b>	A15	A17	D24	D23	D21	PB17	PB19	UART1_CTS	SPI1_MOSI	N.C.	CLS	CONTRAST	ACD/OE	LP/HSYNC	FLM/VSYN	LD1	<b>G</b>
<b>H</b>	A13	D22	A14	D20	NVDD1	NVDD1	NVSS	QVSS	QVDD1	PS	LD0	LD2	LD4	LD5	LD9	LD3	<b>H</b>
<b>J</b>	A12	A11	D18	D19	NVDD1	NVDD1	NVSS	NVDD1	NVSS	NVSS	LD6	LD7	LD8	LD11	QVDD3	QVSS	<b>J</b>
<b>K</b>	A10	D16	A9	D17	NVDD1	NVSS	NVSS	NVDD1	NVDD2	NVDD2	LD10	LD12	LD13	LD14	TMR2OUT	LD15	<b>K</b>
<b>L</b>	A8	A7	D13	D15	D14	NVDD1	NVSS	CAS	TCK	TIN	PWMO	CSI_MCLK	CSI_D0	CSI_D1	CSI_D2	CSI_D3	<b>L</b>
<b>M</b>	A5	D12	D11	A6	SDCLK	NVSS	RW	MA10	RAS	RESET_IN	BIG_ENDIAN	CSI_D4	CSI_HSYNC	CSI_VSYNC	CSI_D6	CSI_D5	<b>M</b>
<b>N</b>	A4	EB1	D10	D7	A0	D4	PA17	D1	DQM1	RESET_SF1	RESET_OUT	BOOT2	CSI_PIXCLK	CSI_D7	TMS	TDI	<b>N</b>
<b>P</b>	A3	D9	EB0	CS3	D6	ECB	D2	D3	DQM3	SDCKE1	BOOT3	BOOT0	TRST	I2C_SCL	I2C_SDA	XTAL32K	<b>P</b>
<b>R</b>	EB2	EB3	A1	CS4	D8	D5	LBA	BCLK <sup>2</sup>	D0	DQM0	SDCKE0	POR	BOOT1	TD0	QVDD2	EXTAL32K	<b>R</b>
<b>T</b>	NVSS	A2	OE	CS5	CS2	CS1	CS0	MA11	DQM2	SDWE	CLKO	AVDD1	TRISTATE	EXTAL16M	XTAL16M	QVSS	<b>T</b>
	1	2	3	4	5	6	7	8	9	10	11	12	13	14	15	16	

<sup>1</sup> This signal is not used and should be floated in an actual application.

<sup>2</sup> burst clock

Table 38 illustrates the package pin assignments for the 225-contact MAPBGA package. For a complete listing of signals, see the Signal Multiplexing Table 3 on page 9.

**Table 38. i.MXL 225 MAPBGA Pin Assignments**

	1	2	3	4	5	6	7	8	9	10	11	12	13	14	15	
<b>A</b>	SD_CMD	PB15	PB19	$\overline{\text{USB}}_{\text{D}}_{\text{ROE}}$	USB <sub>D</sub> _SUSPND	USB <sub>D</sub> _VM	SSI <sub>1</sub> _RXFS	SSI <sub>1</sub> _TXCLK	SPI <sub>1</sub> _SPI <sub>1</sub> _RDY	SPI <sub>1</sub> _SCLK	REV	PS	LD2	LD4	LD5	<b>A</b>
<b>B</b>	SD_DAT3	SD_CLK	PB16	USB <sub>D</sub> _AFE	USB <sub>D</sub> _RCV	USB <sub>D</sub> _VMO	SSI <sub>1</sub> _RXDAT	UART <sub>1</sub> _TXD	SPI <sub>1</sub> _SS	LSCLK	SPL <sub>1</sub> _SPR	LD0	LD3	LD6	LD7	<b>B</b>
<b>C</b>	D31	SD_DAT0	PB14	PB18	SD_DAT2	USB <sub>D</sub> _VPO	UART <sub>2</sub> _RXD	SSI <sub>1</sub> _TXFS	$\overline{\text{UART}}_{1\text{RTS}}$	CONTRAST	FLM/VSYNC	LD8	LD9	LD12	NVDD2	<b>C</b>
<b>D</b>	A23	A24	SD_DAT1	PB17	NVDD1	USB <sub>D</sub> _VP	QVDD4	UART <sub>2</sub> _TXD	NVDD3	SPI <sub>1</sub> _MOSI	LP/HSYNC	LD1	LD11	TMR2OUT	LD13	<b>D</b>
<b>E</b>	A21	A22	D30	D29	NVDD1	QVSS	$\overline{\text{UART}}_{2\text{RTS}}$	UART <sub>1</sub> _RXD	$\overline{\text{UART}}_{1\text{CTS}}$	SPI <sub>1</sub> _MISO	ACD/OE	LD10	TIN	CSI_D0	CSI_MCLK	<b>E</b>
<b>F</b>	A20	A19	D28	D27	NVDD1	NVDD1	$\overline{\text{UART}}_{2\text{CTS}}$	SSI <sub>1</sub> _RXCLK	SSI <sub>1</sub> _TXDAT	CLS	QVDD3	LD14	LD15	CSI_D2	CSI_D4	<b>F</b>
<b>G</b>	A17	A18	D26	D25	NVDD1	NVSS	NVDD4	NVSS	NVSS	QVSS	PWMO	CSI_D3	CSI_D7	CSI_HSYNC	CSI_D5	<b>G</b>
<b>H</b>	A15	A16	D23	D24	D22	NVSS	NVSS	NVSS	NVSS	NVDD2	CSI_D1	CSI_VSYNC	CSI_PIXCLK	I2C_SDA	TMS	<b>H</b>
<b>J</b>	A14	A12	D21	D20	NVDD1	NVSS	NVSS	QVDD1	NVSS	CSI_D6	I2C_SCL	TCK	$\overline{\text{TDO}}$	BOOT1	BOOT0	<b>J</b>
<b>K</b>	A13	A11	$\overline{\text{CS}}_{2}$	D19	NVDD1	NVSS	QVSS	NVDD1	NVSS	D1	BOOT2	TDI	BIG_ENDIAN	$\overline{\text{RESET}}_{\text{OUT}}$	XTAL32K	<b>K</b>
<b>L</b>	A10	A9	D17	D18	NVDD1	NVDD1	$\overline{\text{CS}}_{5}$	D2	$\overline{\text{ECB}}$	NVSS	NVSS	POR	QVSS	XTAL16M	EXTAL32K	<b>L</b>
<b>M</b>	D16	D15	D13	D10	$\overline{\text{EB}}_{3}$	NVDD1	$\overline{\text{CS}}_{4}$	$\overline{\text{CS}}_{1}$	BCLK <sup>1</sup>	$\overline{\text{RW}}$	NVSS	BOOT3	QVDD2	$\overline{\text{RESET}}_{\text{IN}}$	EXTAL16M	<b>M</b>
<b>N</b>	A8	A7	D12	$\overline{\text{EB}}_{0}$	D9	D8	$\overline{\text{CS}}_{3}$	$\overline{\text{CS}}_{0}$	PA17	D0	DQM2	DQM0	SDCKE0	TRISTATE	$\overline{\text{TRST}}$	<b>N</b>
<b>P</b>	D14	A5	A4	A3	A2	A1	D6	D5	MA10	MA11	DQM1	$\overline{\text{RAS}}$	SDCKE1	CLKO	$\overline{\text{RESET}}_{\text{SF}}^2$	<b>P</b>
<b>R</b>	A6	D11	$\overline{\text{EB}}_{1}$	$\overline{\text{EB}}_{2}$	$\overline{\text{OE}}$	D7	A0	SDCLK	D4	$\overline{\text{LBA}}$	D3	DQM3	$\overline{\text{CAS}}$	$\overline{\text{SDWE}}$	AVDD1	<b>R</b>
	1	2	3	4	5	6	7	8	9	10	11	12	13	14	15	

<sup>1</sup> Burst Clock

<sup>2</sup> This signal is not used and should be floated in an actual application.

## 5.1 MAPBGA 256 Package Dimensions

Figure 67 illustrates the 256 MAPBGA 14 mm × 14 mm × 1.30 mm package, with an 0.8 mm pad pitch. The device designator for the MAPBGA package is VH.



**NOTES:**

1. ALL DIMENSIONS ARE IN MILLIMETERS.
2. INTERPRET DIMENSIONS AND TOLERANCES PER ASME Y14.5M-1994.
3. MAXIMUM SOLDER BALL DIAMETER MEASURED PARALLEL TO DATUM A.
4. DATUM A, THE SEATING PLANE IS DEFINED BY SPHERICAL CROWNS OF THE SOLDER BALLS.

**Figure 67. i.MXL 256 MAPBGA Mechanical Drawing**

## 5.2 MAPBGA 225 Package Dimensions

Figure 68 illustrates the 225 MAPBGA 13 mm × 13 mm package.

### Case Outline 1304B

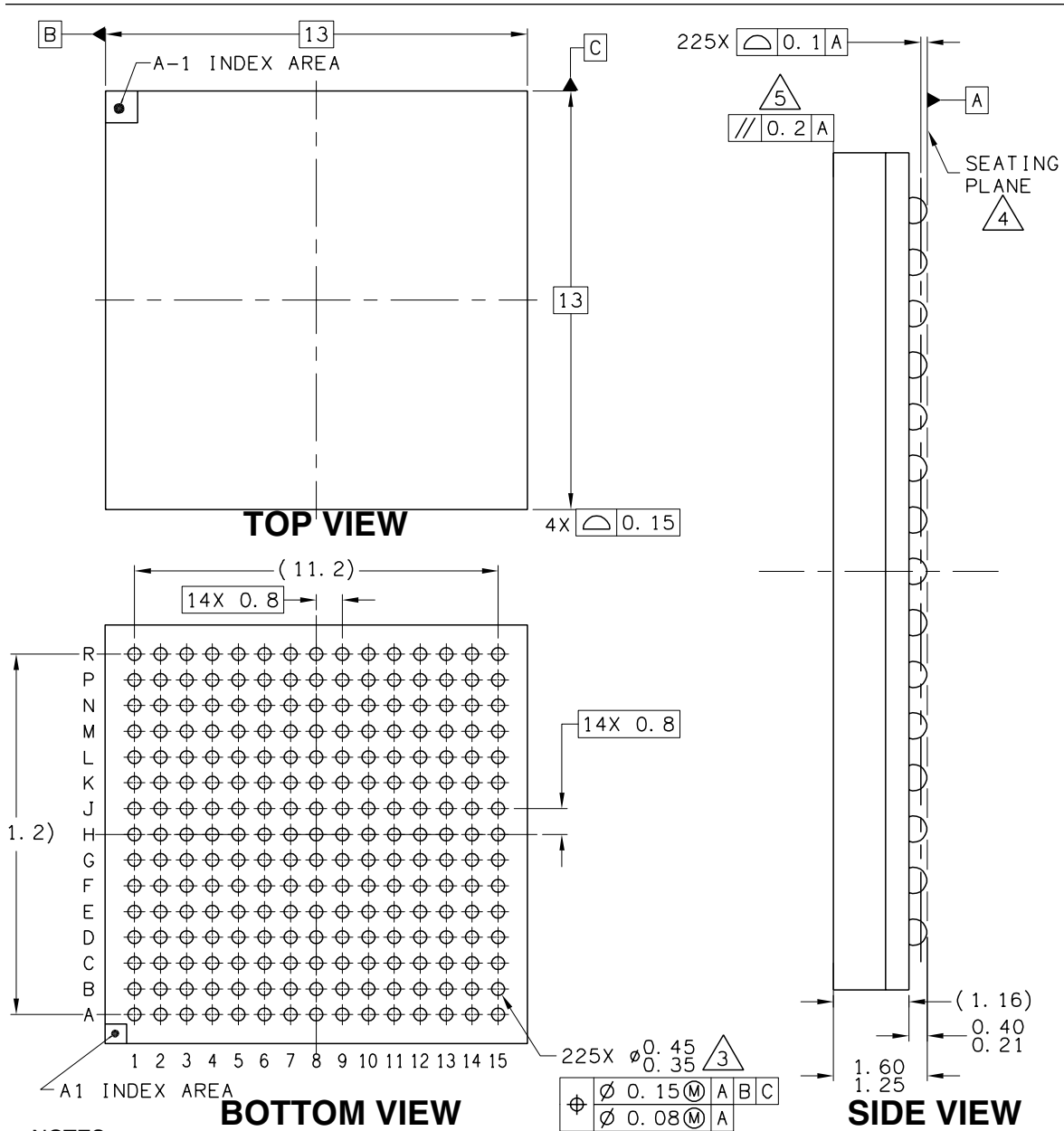

**NOTES:**

- 1. ALL DIMENSIONS ARE IN MILLIMETERS.
- 2. DIMENSIONS AND TOLERANCES PER ASME Y14.5M-1994.
- 3. MAXIMUM SOLDER BALL DIAMETER MEASURED PARALLEL TO DATUM A.
- 4. DATUM A, THE SEATING PLANE IS DEFINED BY SPHERICAL CROWNS OF THE SOLDER BALLS.
- 5. PARALLELISM MEASUREMENT SHALL EXCLUDE ANY EFFECT OF MARK ON TOP SURFACE OF PACKAGE.

Figure 68. i.MXL 225 MAPBGA Mechanical Drawing

## 6 Product Documentation

### 6.1 Revision History

Table 39 provides revision history for this release. This history includes technical content revisions only and not stylistic or grammatical changes.

**Table 39. i.MXL Data Sheet Revision History Rev. 8**

Location	Revision
Table 2 on page 4 Signal Names and Descriptions	<ul style="list-style-type: none"> <li>Added the DMA_REQ signal to table.</li> <li>Corrected signal name from <math>\overline{\text{USB\_OE}}</math> to <math>\overline{\text{USB\_ROE}}</math></li> </ul>
Table 3 on page 9 Signal Multiplex Table i.MXL	Added Signal Multiplex table from Reference Manual with the following changes: <ul style="list-style-type: none"> <li>Changed I/O Supply Voltage, PB31–20, from NVDD3 to NVDD4</li> <li>Added 225 BGA column.</li> <li>Removed 69K pull-up resistor from EB1, EB2, and added to D9</li> </ul>
Table 10 on page 21	Changed first and second parameters descriptions: From: Reference Clock freq range, To: DPLL input clock freq range From: Double clock freq range, To: DPLL output freq range
Table 3 on page 9	Added Signal Multiplex table.

### 6.2 Reference Documents

The following documents are required for a complete description of the MC9328MXL and are necessary to design properly with the device. Especially for those not familiar with the ARM920T processor or previous i.MX processor products, the following documents are helpful when used in conjunction with this document.

*ARM Architecture Reference Manual* (ARM Ltd., order number ARM DDI 0100)

*ARM9DT1 Data Sheet Manual* (ARM Ltd., order number ARM DDI 0029)

*ARM Technical Reference Manual* (ARM Ltd., order number ARM DDI 0151C)

*EMT9 Technical Reference Manual* (ARM Ltd., order number DDI O157E)

*MC9328MXL Product Brief* (order number MC9328MXLP)

*MC9328MXL Reference Manual* (order number MC9328MXLRM)

The Freescale manuals are available on the Freescale Semiconductors Web site at <http://www.freescale.com/imx>. These documents may be downloaded directly from the Freescale Web site, or printed versions may be ordered. The ARM Ltd. documentation is available from <http://www.arm.com>.





**NOTES**

**How to Reach Us:**

**Home Page:**  
[www.freescale.com](http://www.freescale.com)

**E-mail:**  
[support@freescale.com](mailto:support@freescale.com)

**USA/Europe or Locations Not Listed:**  
Freescale Semiconductor  
Technical Information Center, CH370  
1300 N. Alma School Road  
Chandler, Arizona 85224  
+1-800-521-6274 or +1-480-768-2130  
[support@freescale.com](mailto:support@freescale.com)

**Europe, Middle East, and Africa:**  
Freescale Halbleiter Deutschland GmbH  
Technical Information Center  
Schatzbogen 7  
81829 Muenchen, Germany  
+44 1296 380 456 (English)  
+46 8 52200080 (English)  
+49 89 92103 559 (German)  
+33 1 69 35 48 48 (French)  
[support@freescale.com](mailto:support@freescale.com)

**Japan:**  
Freescale Semiconductor Japan Ltd.  
Headquarters  
ARCO Tower 15F  
1-8-1, Shimo-Meguro, Meguro-ku,  
Tokyo 153-0064, Japan  
0120 191014 or +81 3 5437 9125  
[support.japan@freescale.com](mailto:support.japan@freescale.com)

**Asia/Pacific:**  
Freescale Semiconductor Hong Kong Ltd.  
Technical Information Center  
2 Dai King Street  
Tai Po Industrial Estate  
Tai Po, N.T., Hong Kong  
+800 2666 8080  
[support.asia@freescale.com](mailto:support.asia@freescale.com)

**For Literature Requests Only:**  
Freescale Semiconductor Literature Distribution Center  
P.O. Box 5405  
Denver, Colorado 80217  
1-800-521-6274 or 303-675-2140  
Fax: 303-675-2150  
[LDCForFreescaleSemiconductor@hibbertgroup.com](mailto:LDCForFreescaleSemiconductor@hibbertgroup.com)

Information in this document is provided solely to enable system and software implementers to use Freescale Semiconductor products. There are no express or implied copyright licenses granted hereunder to design or fabricate any integrated circuits or integrated circuits based on the information in this document.

Freescale Semiconductor reserves the right to make changes without further notice to any products herein. Freescale Semiconductor makes no warranty, representation or guarantee regarding the suitability of its products for any particular purpose, nor does Freescale Semiconductor assume any liability arising out of the application or use of any product or circuit, and specifically disclaims any and all liability, including without limitation consequential or incidental damages. "Typical" parameters that may be provided in Freescale Semiconductor data sheets and/or specifications can and do vary in different applications and actual performance may vary over time. All operating parameters, including "Typicals", must be validated for each customer application by customer's technical experts. Freescale Semiconductor does not convey any license under its patent rights nor the rights of others. Freescale Semiconductor products are not designed, intended, or authorized for use as components in systems intended for surgical implant into the body, or other applications intended to support or sustain life, or for any other application in which the failure of the Freescale Semiconductor product could create a situation where personal injury or death may occur. Should Buyer purchase or use Freescale Semiconductor products for any such unintended or unauthorized application, Buyer shall indemnify and hold Freescale Semiconductor and its officers, employees, subsidiaries, affiliates, and distributors harmless against all claims, costs, damages, and expenses, and reasonable attorney fees arising out of, directly or indirectly, any claim of personal injury or death associated with such unintended or unauthorized use, even if such claim alleges that Freescale Semiconductor was negligent regarding the design or manufacture of the part.

Freescale™ and the Freescale logo are trademarks of Freescale Semiconductor, Inc. ARM and the ARM POWERED logo are the registered trademarks of ARM Limited. ARM9, ARM920T, and ARM9TDMI are the trademarks of ARM Limited. All other product or service names are the property of their respective owners.

© Freescale Semiconductor, Inc. 2006. All rights reserved.

RoHS-compliant and/or Pb-free versions of Freescale products have the functionality and electrical characteristics of their non-RoHS-compliant and/or non-Pb-free counterparts. For further information, see <http://www.freescale.com> or contact your Freescale sales representative.

For information on Freescale's Environmental Products program, go to <http://www.freescale.com/epp>.

Компания «Life Electronics» занимается поставками электронных компонентов импортного и отечественного производства от производителей и со складов крупных дистрибьюторов Европы, Америки и Азии.

С конца 2013 года компания активно расширяет линейку поставок компонентов по направлению коаксиальный кабель, кварцевые генераторы и конденсаторы (керамические, пленочные, электролитические), за счёт заключения дистрибьюторских договоров

Мы предлагаем:

- Конкурентоспособные цены и скидки постоянным клиентам.
- Специальные условия для постоянных клиентов.
- Подбор аналогов.
- Поставку компонентов в любых объемах, удовлетворяющих вашим потребностям.
- Приемлемые сроки поставки, возможна ускоренная поставка.
- Доставку товара в любую точку России и стран СНГ.
- Комплексную поставку.
- Работу по проектам и поставку образцов.
- Формирование склада под заказчика.
- Сертификаты соответствия на поставляемую продукцию (по желанию клиента).
- Тестирование поставляемой продукции.
- Поставку компонентов, требующих военную и космическую приемку.
- Входной контроль качества.
- Наличие сертификата ISO.

В составе нашей компании организован Конструкторский отдел, призванный помогать разработчикам, и инженерам.

Конструкторский отдел помогает осуществить:

- Регистрацию проекта у производителя компонентов.
- Техническую поддержку проекта.
- Защиту от снятия компонента с производства.
- Оценку стоимости проекта по компонентам.
- Изготовление тестовой платы монтаж и пусконаладочные работы.



Тел: +7 (812) 336 43 04 (многоканальный)

Email: [org@lifeelectronics.ru](mailto:org@lifeelectronics.ru)