



### Main

Range of product	Harmony XVGU
Product or component type	USB configurable monolithic tower light
Beacon or indicator bank unit type	3 illuminated units
Sound signalling	Buzzer
Mounting diameter	2.36 in (60 mm)
Component name	XVGU
Light source	Multi-colour LED with steady or flashing signalling
Indicator bank base type	Base with integrated buzzer
Noise level	85 dB (2 tone buzzer signalling) at 1 m

### Complementary

Material	PC (globe)
Device mounting	Tube mounting with fixing plate
Light block color	Clear/clear/clear
[Us] rated supply voltage	5 V DC
Connector type	USB type A female
Current consumption	400 mA
Sound frequency	3800 Hz 2700 Hz
Power consumption in W	2 W
Flashing frequency	2 Hz with flashing LED unit 1 Hz with flashing LED unit
Product compatibility	Vijeo Designer 4.6( indoor use only) HMIGTO XBTGT.... XBTGK.... XBTGC1. XBTGC2. XBTGH
Product weight	0.66 lb(US) (0.3 kg)

### Environment

standards	EN 61000-6-2 EN 61000-6-4
product certifications	CE CUL GOST UL 508 RCM
ambient air temperature for storage	-31...158 °F (-35...70 °C)
ambient air temperature for operation	32...131 °F (0...55 °C)
electrical shock protection class	Class I
IP degree of protection	IP54

### Offer Sustainability

Green Premium product	Green Premium product
Compliant - since 1529 - Schneider Electric declaration of conformity	Compliant - since 1529 - Schneider Electric declaration of conformity
Reference not containing SVHC above the threshold	Reference not containing SVHC above the threshold
Available	Available

The information provided in this documentation contains general descriptions and/or technical characteristics of the products contained herein. This documentation is not intended as a substitute for and is not to be used for determining suitability or reliability of these products for specific user applications. It is the duty of any such user or integrator to perform the appropriate and complete risk analysis, evaluation and testing of the products with respect to the relevant specific application or use thereof. Neither Schneider Electric Industries SAS nor any of its affiliates or subsidiaries shall be responsible or liable for misuse of the information contained herein.

Need no specific recycling operations

Need no specific recycling operations

WARNING: This product can expose you to chemicals including:

WARNING: This product can expose you to chemicals including:

Lead and lead compounds, which is known to the State of California to cause cancer and birth defects or other reproductive harm.

Lead and lead compounds, which is known to the State of California to cause cancer and birth defects or other reproductive harm.

For more information go to [www.p65warnings.ca.gov](http://www.p65warnings.ca.gov)

For more information go to [www.p65warnings.ca.gov](http://www.p65warnings.ca.gov)

## Dimensions

### Tube Mounting with Fixing Plate

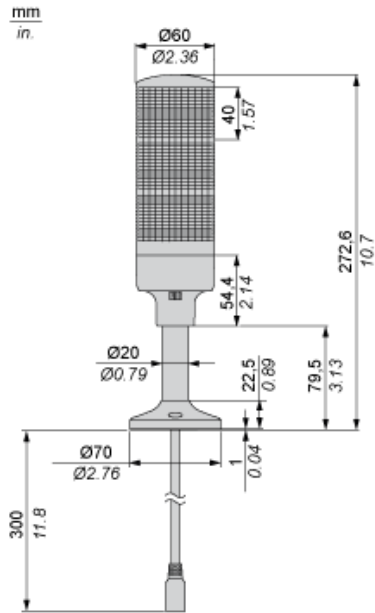

### Mounting on Horizontal Support for Tube Mounting with Fixing Plate

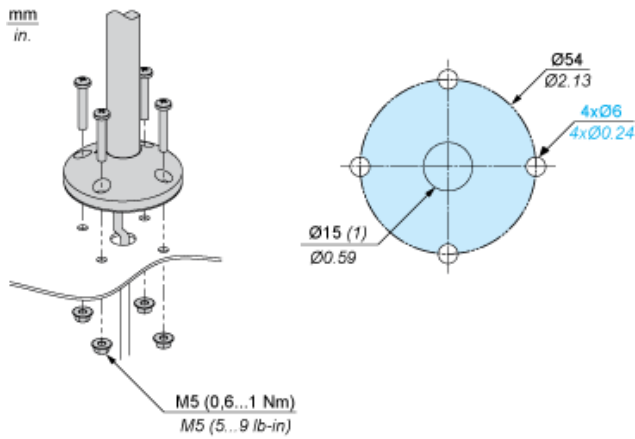

(1) Cable outlet

### Mounting Orientation

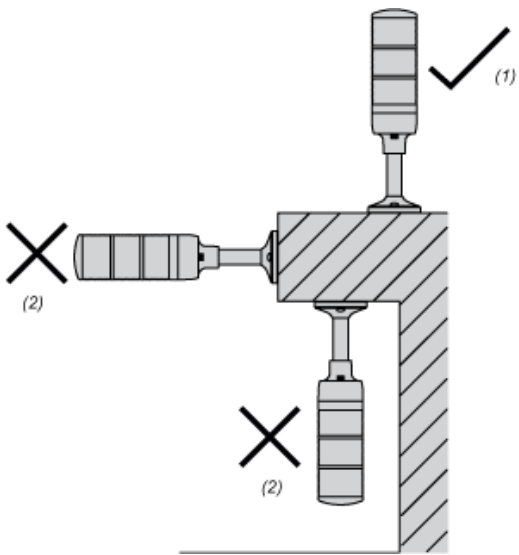

Choose a flat surface with enough strength and with little vibration for installation. Mount this product according to the figure to maintain IP characteristics.

- (1) OK
- (2) NO

Компания «Life Electronics» занимается поставками электронных компонентов импортного и отечественного производства от производителей и со складов крупных дистрибьюторов Европы, Америки и Азии.

С конца 2013 года компания активно расширяет линейку поставок компонентов по направлению коаксиальный кабель, кварцевые генераторы и конденсаторы (керамические, пленочные, электролитические), за счёт заключения дистрибьюторских договоров

Мы предлагаем:

- Конкуренеспособные цены и скидки постоянным клиентам.
- Специальные условия для постоянных клиентов.
- Подбор аналогов.
- Поставку компонентов в любых объемах, удовлетворяющих вашим потребностям.
- Приемлемые сроки поставки, возможна ускоренная поставка.
- Доставку товара в любую точку России и стран СНГ.
- Комплексную поставку.
- Работу по проектам и поставку образцов.
- Формирование склада под заказчика.
- Сертификаты соответствия на поставляемую продукцию (по желанию клиента).
- Тестирование поставляемой продукции.
- Поставку компонентов, требующих военную и космическую приемку.
- Входной контроль качества.
- Наличие сертификата ISO.

В составе нашей компании организован Конструкторский отдел, призванный помогать разработчикам, и инженерам.

Конструкторский отдел помогает осуществить:

- Регистрацию проекта у производителя компонентов.
- Техническую поддержку проекта.
- Защиту от снятия компонента с производства.
- Оценку стоимости проекта по компонентам.
- Изготовление тестовой платы монтаж и пусконаладочные работы.



Тел: +7 (812) 336 43 04 (многоканальный)

Email: [org@lifeelectronics.ru](mailto:org@lifeelectronics.ru)